



**CONTACTS, ELECTRICAL, CRIMP, WIRE-WRAP,
SOLDER AND SAVER FOR 3401/016
CONNECTORS**

ESCC Detail Specification No. 3401/017

Issue 6	November 2021
---------	---------------



LEGAL DISCLAIMER AND COPYRIGHT

European Space Agency, Copyright © 2021. All rights reserved.

The European Space Agency disclaims any liability or responsibility, to any person or entity, with respect to any loss or damage caused, or alleged to be caused, directly or indirectly by the use and application of this ESCC publication.

This publication, without prior permission of the European Space Agency and provided that it is not used for a commercial purpose, may be:

- Copied in whole, in any medium, without alteration or modification.
- Copied in part, in any medium, provided that the ESCC document identification, comprising the ESCC symbol, document number and document issue, is removed.

DOCUMENTATION CHANGE NOTICE

(Refer to <https://escies.org> for ESCC DCR content)

DCR No.	CHANGE DESCRIPTION
1457	Specification upissued to incorporate changes per DCR.

TABLE OF CONTENTS

1	GENERAL	6
1.1	SCOPE	6
1.2	COMPONENT TYPE VARIANTS	6
1.3	MAXIMUM RATINGS	6
1.4	PARAMETER DERATING INFORMATION (FIGURE 1)	6
1.5	PHYSICAL DIMENSIONS	6
2	APPLICABLE DOCUMENTS	6
3	TERMS, DEFINITIONS, ABBREVIATIONS, SYMBOLS AND UNITS	6
4	REQUIREMENTS	17
4.1	GENERAL	17
4.2	DEVIATIONS FROM GENERIC SPECIFICATION	17
4.2.1	Deviations from Special In-process Controls	17
4.2.2	Deviations from Final Production Tests - Chart II	17
4.2.3	Deviations from Burn-in and Electrical Measurements (Chart III)	17
4.2.4	Deviations from Qualification Tests - Chart IV	17
4.2.5	Deviations from Lot Acceptance Tests - Chart V	17
4.3	MECHANICAL REQUIREMENTS	17
4.3.1	Dimension Check	17
4.3.2	Weight	17
4.3.3	Contact Capability	17
4.3.4	Contact Retention (In Insert)	17
4.3.5	Mating and Unmating Forces	18
4.3.6	Insert Retention (In Shell)	18
4.3.7	Jackscrew Retention	18
4.3.8	Contact Insertion and Withdrawal Forces	18
4.3.9	Engagement and Separation Forces	18
4.3.10	Oversize Pin Exclusion	18
4.3.11	Probe Damage	18
4.3.12	Solderability	18
4.4	MATERIALS AND FINISHES	18
4.4.1	Shells	18
4.4.2	Inserts	18
4.4.3	Contacts	18
4.4.4	Contact Retaining Clip	19
4.4.5	Guiding and Locking Devices	19
4.4.6	Magnetism Level	19

4.5	MARKING	19
4.5.1	General	19
4.5.2	The ESCC Component Number	19
4.5.3	Traceability Information	19
4.6	ELECTRICAL MEASUREMENTS	19
4.6.1	Electrical Measurements at Room Temperature	19
4.6.2	Electrical Measurements at High and Low Temperatures (Table 3)	19
4.6.3	Circuits for Electrical Measurements (Figure 4)	19
4.7	BURN-IN AND ELECTRICAL MEASUREMENTS	20
4.8	ENVIRONMENTAL AND ENDURANCE TESTS (CHARTS IV AND V OF ESCC GENERIC SPECIFICATION NO. 3401)	20
4.8.1	Measurements and Inspections on Completion of Environmental Tests	20
4.8.2	Measurements and Inspections at Intermediate Points during Endurance Tests	20
4.8.3	Measurements and Inspections on Completion of Endurance Tests	20
4.8.4	Conditions for Operating Life Test (Part of Endurance Testing)	20
4.8.5	Electrical Circuit for Operating Life Tests (Figure 5)	20
4.8.6	Conditions for High Temperature Storage Test (Part of Endurance Testing)	20
	APPENDIX 'A'	23

1 GENERAL

1.1 SCOPE

This specification details the ratings, physical and electrical characteristics, test and inspection data for Contacts, Electrical, Crimp, Wire-Wrap, Solder and Saver, Gauge 0.6mm, for 3401/016 Connectors.

This specification shall be read in conjunction with:

- ESCC Generic Specification No. 3401, Connectors, Electrical, Non-Filtered Circular and Rectangular
- ESCC Detail Specification No. 3401/016, Connectors, Electrical, Electrical, Printed Circuit Board, Removable Contacts, Crimp, Wire-Wrap, Solder and Saver, based on Type HE801,

the requirements of which are supplemented herein.

1.2 COMPONENT TYPE VARIANTS

The different sizes of contacts specified herein, which are also covered by this specification, are scheduled in Table 1(a).

1.3 MAXIMUM RATINGS

The maximum ratings, which shall not be exceeded at any time during use or storage, applicable to the contacts specified herein, are scheduled in Table 1(b).

1.4 PARAMETER DERATING INFORMATION (FIGURE 1)

Not applicable.

1.5 PHYSICAL DIMENSIONS

The physical dimensions of the contacts specified herein are shown in Figure 2.

2 APPLICABLE DOCUMENTS

The following documents form part of this specification and shall be read in conjunction with it:

- (a) ESCC Generic Specification No. 3401, Connectors, Electrical, Non-Filtered, Circular and Rectangular.
- (b) ESCC Detail Specification No. 3401/016, Connectors, Electrical, Electrical, Printed Circuit Board, Removable Contacts, Crimp, Wire-Wrap, Solder and Saver, based on Type HE801,

3 TERMS, DEFINITIONS, ABBREVIATIONS, SYMBOLS AND UNITS

For the purpose of this specification, the terms, definitions, abbreviations, symbols and units specified in ESCC Basic Specification No. 21300 shall apply.



TABLE 1(a) – TYPE VARIANTS

Variant	Type	Mating End Size Ø mm	Barrel Size	Rated Current Max A	Accept Wire AWG	Max Weight g	Engagement & Separation				Contact Capability		Contact Retent. Force Max N	Contact Insert. Withdr. Forces Max N	Probe Damage			Oversize Pin Excl.		
							Engag. Forces N (1)	Separ. Forces N (1)	Test Pins DIA mm		Weight				Moment N.cm	Probe DIA mm		Force Max N	Test Pin DIA mm	
									Min	Max	Pick-up (2) g	Drop (3) g				Min	Max		Min	Max
01 (6)	MC	0.6	N/A	5	N/A	0.18	-	-	-	-	-	-	40 (4) 25 (5)	20	-	-	-	-	-	-
02 (6)	MC	0.6	N/A	5	N/A	0.21	-	-	-	-	-	-	40 (4) 25 (5)	20	-	-	-	-	-	-
03 (6)	MC	0.6	N/A	5	N/A	0.22	-	-	-	-	-	-	40 (4) 25 (5)	20	-	-	-	-	-	-
04	MR	0.6	22	5	22-24 26	0.2	-	-	-	-	-	-	40 (4) 25 (5)	20	-	-	-	-	-	-
05	NOT TO BE USED																			
06 (6)	MD	0.6	N/A	5	N/A	0.18	-	-	-	-	-	-	40 (4) 25 (5)	20	-	-	-	-	-	-
07 (6)	MD	0.6	N/A	5	N/A	0.18	-	-	-	-	-	-	40 (4) 25 (5)	20	-	-	-	-	-	-
08 (6)	MS	0.6	22	5	22 24	0.22	-	-	-	-	-	-	40 (4) 25 (5)	20	-	-	-	-	-	-
10 (6)	MY	0.6	N/A	5	26-28 30	0.29	-	-	-	-	-	-	40 (4) 25 (5)	20	-	-	-	-	-	-
11 (6)	MY	0.6	N/A	5	26-28 30	0.21	-	-	-	-	-	-	40 (4) 25 (5)	20	-	-	-	-	-	-
12 (6)	FC	0.6	N/A	5	N/A	0.125	0.9 -	0.9 0.14	0.62 0.575	0.625 0.58	- 14	90 -	40 (4) 25 (5)	20	0.5	0.59	0.61	0.9	0.758	0.762
13 (6)	FC	0.6	N/A	5	N/A	0.15	0.9 -	0.9 0.14	0.62 0.575	0.625 0.58	- 14	90 -	40 (4) 25 (5)	20	0.5	0.59	0.61	0.9	0.758	0.762
14 (6)	FC	0.6	N/A	5	N/A	0.155	0.9 -	0.9 0.14	0.62 0.575	0.625 0.58	- 14	90 -	40 (4) 25 (5)	20	0.5	0.59	0.61	0.9	0.758	0.762
15	FR	0.6	22	5	22-24 26	0.145	0.9 -	0.9 0.14	0.62 0.575	0.625 0.58	- 14	90 -	40 (4) 25 (5)	20	0.5	0.59	0.61	0.9	0.758	0.762



Variant	Type	Mating End Size Ø mm	Barrel Size	Rated Current Max A	Accept Wire AWG	Max Weight g	Engagement & Separation				Contact Capability		Contact Retent. Force Max N	Contact Insert. Withdr. Forces Max N	Probe Damage			Oversize Pin Excl.		
							Engag. Forces N (1)	Separ. Forces N (1)	Test Pins DIA mm		Weight				Moment N.cm	Probe DIA mm		Force Max N	Test Pin DIA mm	
									Min	Max	Pick-up (2) g	Drop (3) g				Min	Max		Min	Max
16	NOT TO BE USED																			
17 (6)	FD	0.6	N/A	5	N/A	0.12	0.9 -	0.9 0.14	0.62 0.575	0.625 0.58	- 14	90 -	40 (4) 25 (5)	20	0.5	0.59	0.61	0.9	0.758	0.762
18 (6)	FD	0.6	N/A	5	N/A	0.12	0.9 -	0.9 0.14	0.62 0.575	0.625 0.58	- 14	90 -	40 (4) 25 (5)	20	0.5	0.59	0.61	0.9	0.758	0.762
19 (6)	FS	0.6	22	5	22 24	0.165	0.9 -	0.9 0.14	0.62 0.575	0.625 0.58	- 14	90 -	40 (4) 25 (5)	20	0.5	0.59	0.61	0.9	0.758	0.762
21 (6)	FY	0.6	N/A	5	26-28 30	0.16	0.9 -	0.9 0.14	0.62 0.575	0.625 0.58	- 14	90 -	40 (4) 25 (5)	20	0.5	0.59	0.61	0.9	0.758	0.762
22 (6)	FY	0.6	N/A	5	26-28 30	0.155	0.9 -	0.9 0.14	0.62 0.575	0.625 0.58	- 14	90 -	40 (4) 25 (5)	20	0.5	0.59	0.61	0.9	0.758	0.762
64 (6)	ML	0.6	N/A	5	N/A	0.19	0.9 -	0.9 0.14	0.62 0.575	0.625 0.58	- 14	90 -	40 (4) 25 (5)	20	0.5	0.59	0.61	0.9	0.758	0.762
65 (6)	ML	0.6	N/A	5	N/A	0.21	0.9 -	0.9 0.14	0.62 0.575	0.625 0.58	- 14	90 -	40 (4) 25 (5)	20	0.5	0.59	0.61	0.9	0.758	0.762
66 (6)	ML	0.6	N/A	5	N/A	0.24	-	-	-	-	-	-	40 (4) 25 (5)	20	-	-	-	-	-	-
67 (6)	FM	0.6	N/A	5	N/A	0.12	0.9 -	0.9 0.14	0.62 0.575	0.625 0.58	- 14	90 -	40 (4) 25 (5)	20	0.5	0.59	0.61	0.9	0.758	0.762
68 (6)	FL	0.6	N/A	5	N/A	0.125	0.9 -	0.9 0.14	0.62 0.575	0.625 0.58	- 14	90 -	40 (4) 25 (5)	20	0.5	0.59	0.61	0.9	0.758	0.762
69 (6)	FL	0.6	N/A	5	N/A	0.135	0.9 -	0.9 0.14	0.62 0.575	0.625 0.58	- 14	90 -	40 (4) 25 (5)	20	0.5	0.59	0.61	0.9	0.758	0.762
70 (6)	FL	0.6	N/A	5	N/A	0.16	0.9 -	0.9 0.14	0.62 0.575	0.625 0.58	- 14	90 -	40 (4) 25 (5)	20	0.5	0.59	0.61	0.9	0.758	0.762

NOTES:

1. 1st line, maximum values with maximum diameter test pin; 2nd line, minimum values with minimum diameter test pin.
2. With minimum diameter test pin and minimum insertion depth of 5mm.
3. With maximum diameter test pin and minimum insertion depth of 5mm.
4. Tension.
5. Compression.
6. These variants are delivered mounted in the inserts, and dimensions of the rear part are given in ESCC Detail Specification No. [3401/016](#).

TABLE 1(b) - MAXIMUM RATINGS

No.	Characteristics	Symbol	Maximum Rating	Unit	Remarks
1	Rated Current	I_{CR}	See Table 1(a)	A	
2	Operating Temperature Range	T_{op}	-55 to +125	°C	
3	Storage Temperature Range	T_{stg}	-55 to +125	°C	
4	Soldering Temperature	T_{sol}	+260	°C	Note 1

NOTES:

1. Duration 10 seconds maximum and the same contact shall not be resoldered until 3 minutes have elapsed.

FIGURE 1 - PARAMETER DERATING INFORMATION

Not Applicable.

FIGURE 2 – PHYSICAL DIMENSIONS

VARIANT 01 - SOLDER RIGHT-ANGLE MALE CONTACT

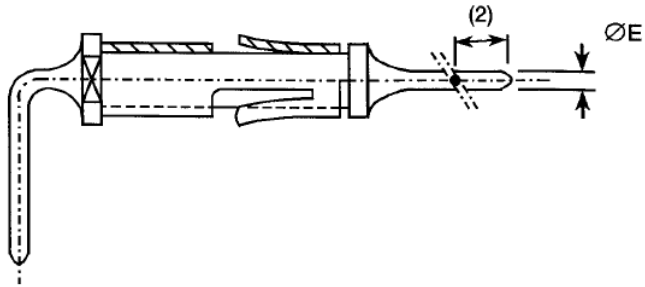

VARIANT 02 - SOLDER RIGHT-ANGLE MALE CONTACT

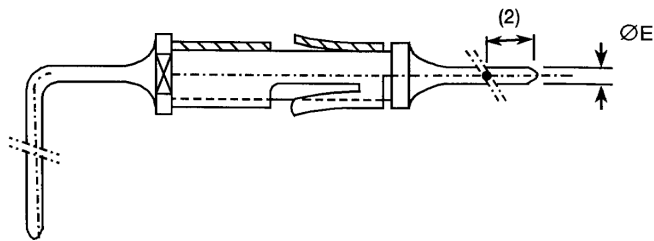

VARIANT 03 - SOLDER RIGHT-ANGLE MALE CONTACT

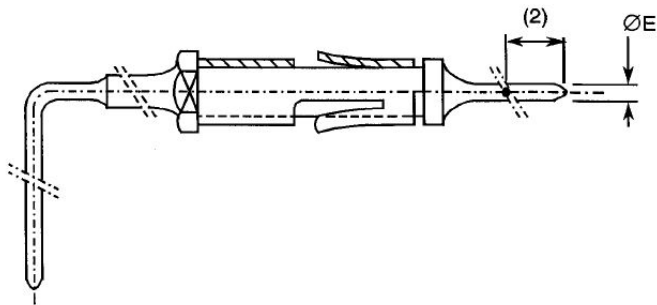

VARIANT 04 - CRIMP MALE CONTACT

SECTION - XX -

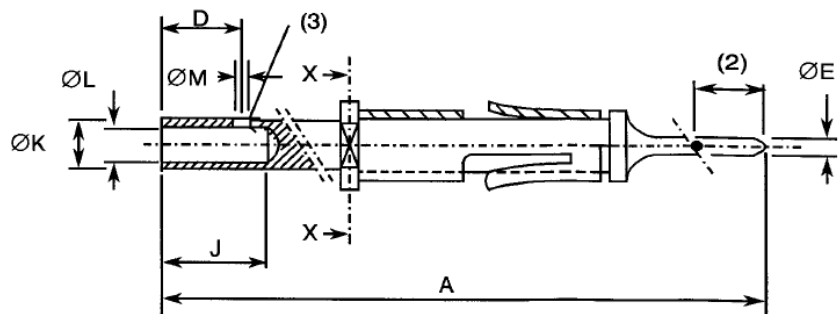
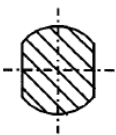

VARIANT 05 - NOT TO BE USEDVARIANT 06 - SOLDER STRAIGHT-THROUGH MALE CONTACT

(Not to be used for new design)

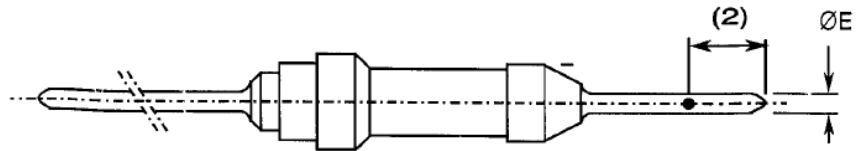
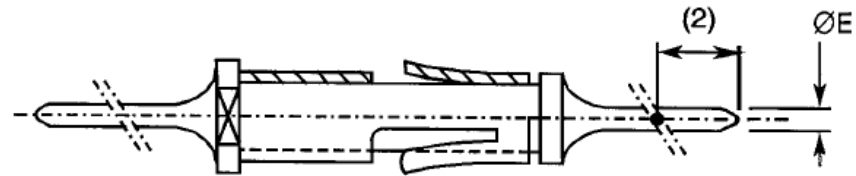
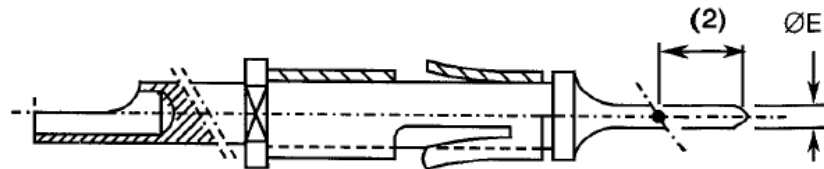
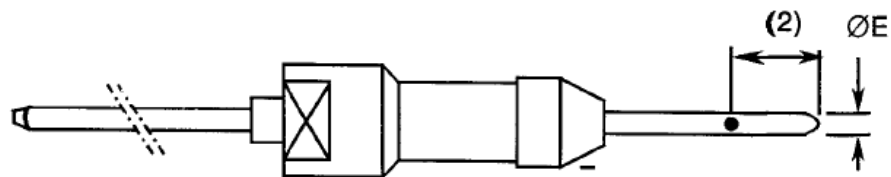
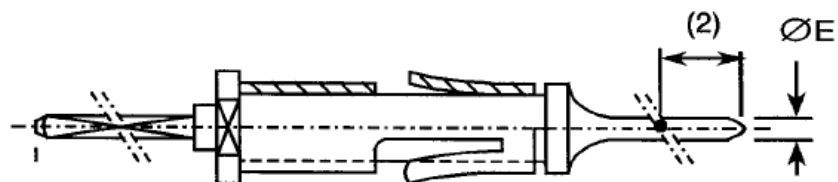
VARIANT 07 - SOLDER STRAIGHT-THROUGH MALE CONTACTVARIANT 08 - SOLDER BUCKET MALE CONTACTVARIANT 10 - WIRE-WRAP MALE CONTACTVARIANT 11 - WIRE-WRAP MALE CONTACT

VARIANT 12 - SOLDER RIGHT-ANGLE FEMALE CONTACT

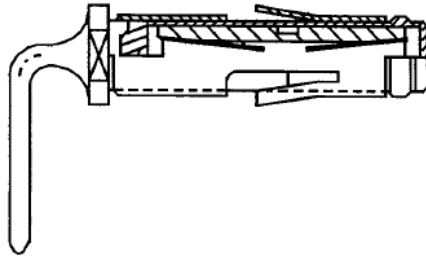

VARIANT 13 - SOLDER RIGHT-ANGLE FEMALE CONTACT

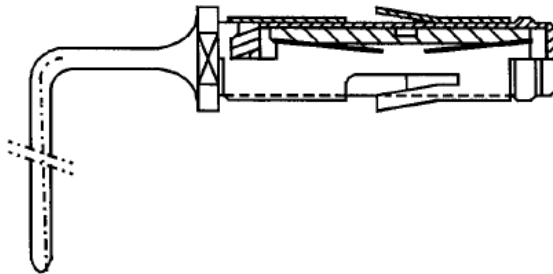

VARIANT 14 - SOLDER RIGHT-ANGLE FEMALE CONTACT

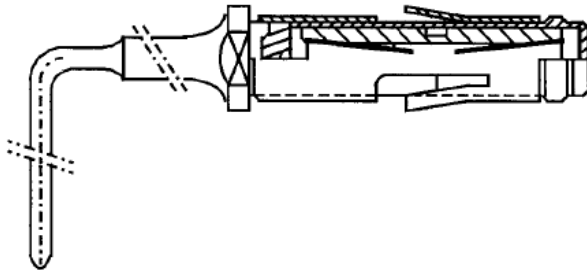

VARIANT 15 - CRIMP FEMALE CONTACT

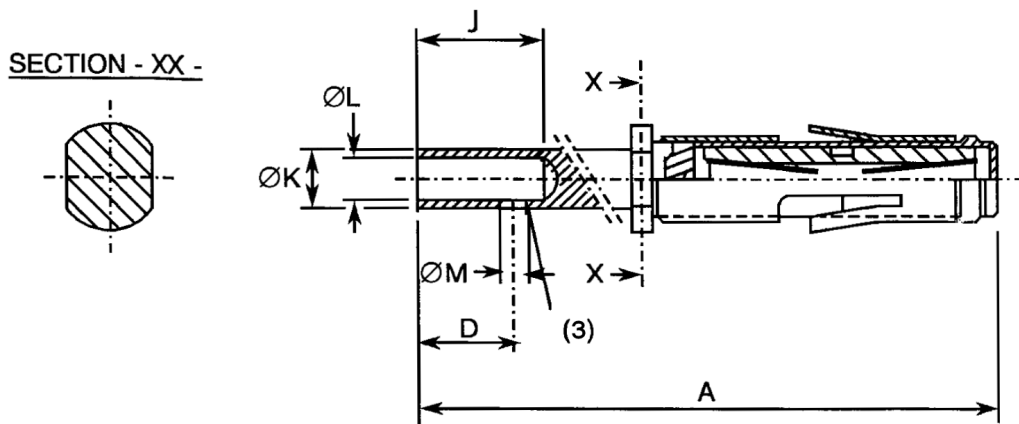

VARIANT 16 - NOT TO BE USED

VARIANT 17- SOLDER STRAIGHT-THROUGH FEMALE CONTACT

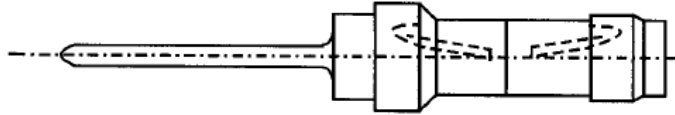

VARIANT 18 - SOLDER STRAIGHT-THROUGH FEMALE CONTACT

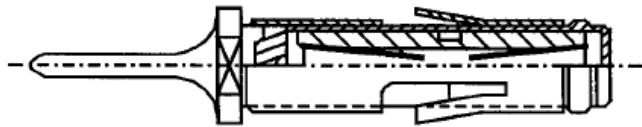

VARIANT 19 - SOLDER BUCKET FEMALE CONTACT

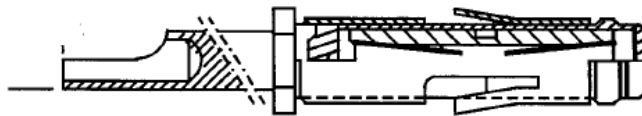

VARIANT 21 - WIRE-WRAP FEMALE CONTACT

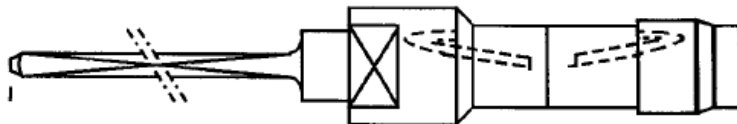

VARIANT 22 - WIRE-WRAP FEMALE CONTACT

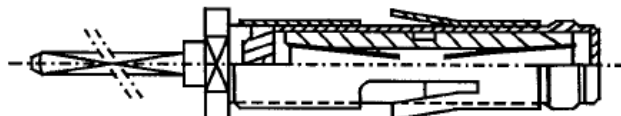

VARIANT 64 - SOLDER RIGHT-ANGLE MALE CONTACT (LONG)

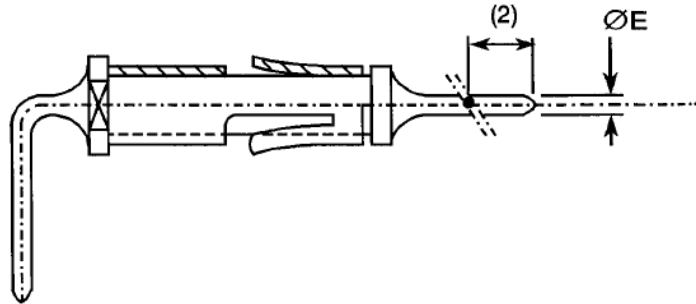

VARIANT 65 - SOLDER RIGHT-ANGLE MALE CONTACT (LONG)

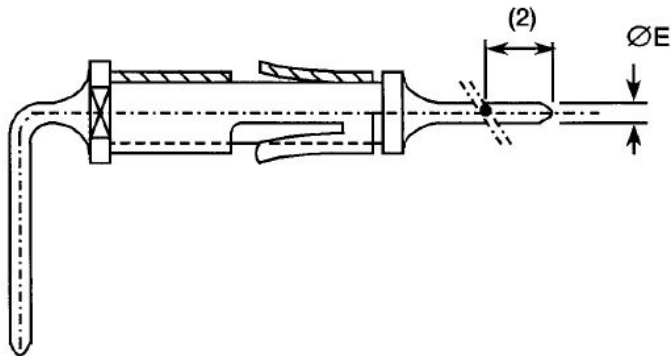

VARIANT 66 - SOLDER RIGHT-ANGLE MALE CONTACT

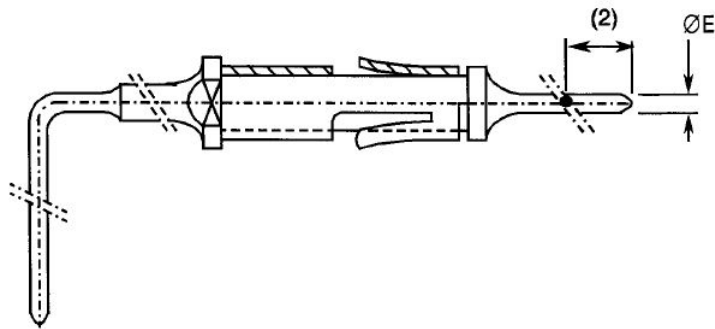

VARIANT 67 - SAVER FEMALE- MALE CONTACT

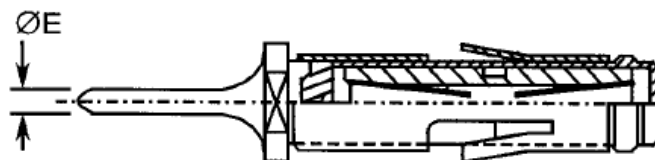

VARIANT 68 - SOLDER RIGHT-ANGLE FEMALE CONTACT

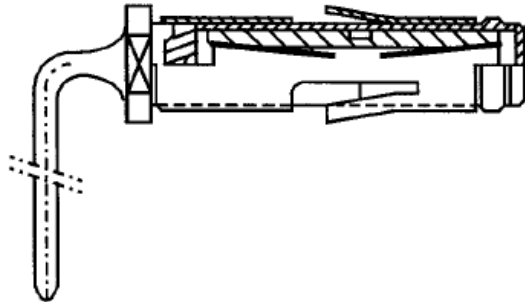

VARIANT 69 - SOLDER RIGHT-ANGLE FEMALE CONTACT

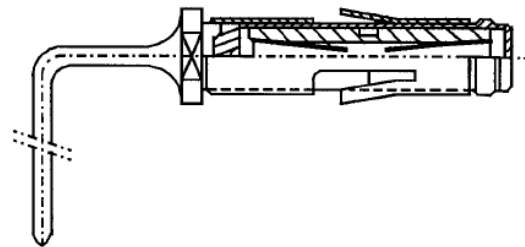

VARIANT 70 - SOLDER RIGHT-ANGLE FEMALE CONTACT

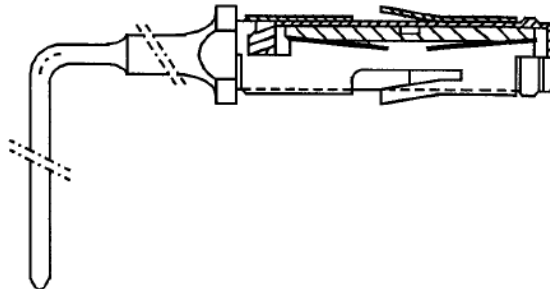

NOTES TO FIGURE 2:

1. All dimensions are in millimetres:

Symbols	Dimensions					
	Variants 01, 02, 03, 06, 07, 08, 10, 11, 64, 65, 66, 67		Variant 04		Variant 15	
	Min	Max	Min	Max	Min	Max
A	-	-	16.3	17.1	11.4	12.2
D	-	-	3.2	4.1	3.2	4.1
ØE	0.575	0.62	0.575	0.62	-	-
J	-	-	3.8	-	3.8	-
ØK	-	-	1.23	1.5	1.23	1.5
ØL	-	-	0.85	0.95	0.85	0.95
ØM	-	-	0.4	0.6	0.4	0.6

2. Measurement point for plating thickness: 2 ± 1 mm.

3. Inspection hole shall only penetrate one wall of the crimp barrel.

4 REQUIREMENTS

4.1 GENERAL

The complete requirements for procurement of the contacts specified herein are stated in this specification and ESCC Generic Specification No. 3401. Deviations from the Generic Specification, applicable to this specification only, are listed in Para. 4.2.

Deviations from the applicable Generic Specification and this Detail Specification, formally agreed with specific Manufacturers on the basis that the alternative requirements are equivalent to the ESCC requirements and do not affect the components' reliability, are listed in the appendices attached to this specification.

4.2 DEVIATIONS FROM GENERIC SPECIFICATION

4.2.1 Deviations from Special In-process Controls

None.

4.2.2 Deviations from Final Production Tests - Chart II

(a) Para. 9.4, Contact Capability: Sampling in accordance with Para. 9.6 of ESCC 3401.

4.2.3 Deviations from Burn-in and Electrical Measurements (Chart III)

Not applicable.

4.2.4 Deviations from Qualification Tests - Chart IV

(a) Para. 9.22, Corrosion: Not applicable.

(b) Para. 9.31, Solderability: Not applicable to Variants 04, 10, 11, 15, 21 and 22.

4.2.5 Deviations from Lot Acceptance Tests - Chart V

(a) Para. 9.22, Corrosion: Not applicable.

(b) Para. 9.31, Solderability: Not applicable to Variants 04, 10, 11, 15, 21 and 22.

4.3 MECHANICAL REQUIREMENTS

4.3.1 Dimension Check

The dimensions of the contacts specified herein shall be verified in accordance with the requirements set out in Para. 9.6 of ESCC Generic Specification No. 3401 and shall conform to those shown in Figure 2 of this specification. Overall dimensions are specified with compatible inserts in ESCC Detail specification No. 3401/016.

4.3.2 Weight

The maximum weight of the contacts specified herein, without contacts, shall be as specified in Table 1(a).

4.3.3 Contact Capability

For the purpose of this test, the pick-up and drop weights shall be as specified in Table 1(a).

4.3.4 Contact Retention (In Insert)

The contact retention force shall be as specified in Table 1(a).

4.3.5 Mating and Unmating Forces

As specified in ESCC Detail Specification No. [3401/016](#).

4.3.6 Insert Retention (In Shell)

As specified in ESCC Detail Specification No. [3401/016](#).

4.3.7 Jackscrew Retention

As specified in ESCC Detail Specification No. [3401/016](#).

4.3.8 Contact Insertion and Withdrawal Forces

The contact insertion and withdrawal forces shall be as specified in Table 1(a).

4.3.9 Engagement and Separation Forces

The diameter of the test pin and the engagement and separation forces of the female contacts shall be as specified in Table 1(a).

4.3.10 Oversize Pin Exclusion

The diameter of the test pin and the force applied to it shall be as specified in Table 1(a).

4.3.11 Probe Damage

The probe diameter and the moment at the end of the probe shall be as specified in Table 1(a).

4.3.12 Solderability

Not applicable to Variants 04, 10, 11, 15, 21 and 22. For all other variants, size B soldering iron shall be used.

4.4 MATERIALS AND FINISHES

The materials and finishes shall be as specified herein. Where a definite material is not specified, a material which will enable the contacts specified herein to meet the performance requirements of this specification shall be used. Acceptance or approval of any constituent material does not guarantee acceptance of the finished product.

4.4.1 Shells

As specified in ESCC Detail Specification No. [3401/016](#).

4.4.2 Inserts

As specified in ESCC Detail Specification No. [3401/016](#).

4.4.3 Contacts

4.4.3.1 *Body*

The contact body shall be made of copper alloy.

Male Contact and Saver: The plating shall be 1.27µm minimum gold over 1.27µm minimum nickel.

Female Contact: The plating shall be 0.25µm minimum gold over 1.27µm minimum nickel.

4.4.3.2 *Female Contact Wire*

The wire shall be made of copper alloy. The plating shall be 1.27µm minimum gold over 0.2µm minimum nickel.

4.4.3.3 *Female Contact Sleeve*

The sleeve shall be made of copper alloy. The plating shall be 0.25µm minimum gold over 0.8µm minimum nickel.

4.4.4 Contact Retaining Clip

The clip shall be made of a beryllium copper alloy.

4.4.5 Guiding and Locking Devices

As specified in ESCC Detail Specification No. [3401/016](#).

4.4.6 Magnetism Level

As specified in ESCC Detail Specification No. [3401/016](#).

4.5 MARKING

4.5.1 General

The marking of all components delivered to this specification shall be in accordance with the requirements of ESCC Basic Specification No. [21700](#) and the following paragraphs.

These components being too small to accommodate the marking as specified hereafter, the full marking information shall accompany each lot of components in its primary package. Such marking shall comprise:

- (a) The ESCC qualified components symbol (for ESCC qualified components only).
- (b) The ESCC Component Number.
- (c) Traceability information.

4.5.2 The ESCC Component Number

The ESCC Component Number shall be constituted and marked as follows:

Example: 340101701B

- Detail Specification Number: 3401017
- Type Variant (see Table 1(a)): 01
- Testing Level: B

4.5.3 Traceability Information

Traceability information shall be marked in accordance with ESCC Basic Specification No. [21700](#).

4.6 ELECTRICAL MEASUREMENTS

4.6.1 Electrical Measurements at Room Temperature

The parameters to be measured in respect of electrical characteristics are scheduled in Table 2. Unless otherwise specified, the measurements shall be performed at $T_{amb} = +22 \pm 3^{\circ}\text{C}$.

4.6.2 Electrical Measurements at High and Low Temperatures (Table 3)

Not applicable.

4.6.3 Circuits for Electrical Measurements (Figure 4)

Not applicable.

4.7 BURN-IN AND ELECTRICAL MEASUREMENTS

Not applicable.

4.8 ENVIRONMENTAL AND ENDURANCE TESTS (CHARTS IV AND V OF ESCC GENERIC SPECIFICATION NO. 3401)

4.8.1 Measurements and Inspections on Completion of Environmental Tests

The parameters to be measured and inspections to be performed on completion of environmental testing shall be those specified in Table 6. Unless otherwise specified, the measurements shall be performed at $T_{amb} = +22 \pm 3^{\circ}C$.

4.8.2 Measurements and Inspections at Intermediate Points during Endurance Tests

Not applicable.

4.8.3 Measurements and Inspections on Completion of Endurance Tests

The parameters to be measured and inspections to be performed on completion of endurance tests shall be those specified in Table 6. Unless otherwise specified, the measurements shall be performed at $T_{amb} = +22 \pm 3^{\circ}C$.

4.8.4 Conditions for Operating Life Test (Part of Endurance Testing)

Not applicable.

4.8.5 Electrical Circuit for Operating Life Tests (Figure 5)

Not applicable.

4.8.6 Conditions for High Temperature Storage Test (Part of Endurance Testing)

The requirements for the high temperature storage test are specified in Section 9 of ESCC Generic Specification No. 3401. The conditions for high temperature storage testing shall be the maximum storage temperature specified in Table 1(b) of this specification.

TABLE 2 – ELECTRICAL MEASUREMENTS AT ROOM TEMPERATURE

No.	Characteristics	Symbol	Spec. and/or Test Method	Test Condition	Variants	Limits		Unit
						Min	Max	
1	Contact Resistance (Low Level Current) (1)	Rcl	ESCC No. 3401 Para 9.1.1.3	Para 9.1.1.3	All	-	8	mΩ
2	Contact Resistance (Rated Current) (1)	Rcr	ESCC No. 3401 Para 9.1.1.3	Para 9.1.1.3 5.0A	All	-	8	mΩ

NOTES:

- Contact Resistance at Low Level Current and at Rated Current is guaranteed but not tested during Final Production Tests (Chart II).

TABLES 3, 4 AND 5

Not applicable

TABLE 6 – MEASUREMENTS AND INSPECTIONS ON COMPLETION OF ENVIRONMENTAL AND ENDURANCE TESTING

No.	ESCC Generic Spec. No. 3401		Measurements and Inspections		Symbol	Limits		Unit
	Environmental and Endurance Tests (1)	Test Method and Conditions	Identification	Conditions		Min	Max	
01	Seal Test	Para. 9.9	ESCC 3401/016	-	-	-	-	
02	Wiring	Para. 9.10 & Table 1(a) of this spec.	Low Level Contact Resistance	Table 2 Item 1	Rcl	Table 2 Item 1		
03	Vibration	Para. 9.11	ESCC 3401/016	-	-	-	-	
04	Shock or Bump	Para. 9.12	ESCC 3401/016	-	-	-	-	
05	Climatic Sequence	Para. 9.13	ESCC 3401/016	-	-	-	-	
06	Plating Thickness	Para. 9.14	Thickness	-	-	Para. 4.4.3 of this spec.		
07	Joint Strength	Para. 9.15	ESCC 3401 Para. 9.15	-	-	-	-	
08	Rapid Change of Temperature	Para. 9.16	ESCC 3401/016	-	-	-	-	
09	Contact Retention (In Insert)	Para. 9.17 & Para. 4.3.4 of this spec.	Contact Displacement	-	-	ESCC 3401 Para. 9.17		
10	Endurance	Para. 9.18	Initial Measurements Low Level Contact Resistance	Table 2 Item 1	Rcl	Record Values		mΩ
			Final Measurements Low Level Contact Resistance Drift	Table 2 Item 1	ΔRcl	-	4	
11	Permanence of Marking	Para. 9.19	As applicable	-	-	-	-	
12	Mating/Unmating Forces	Para. 9.20	ESCC 3401/016	-	-	-	-	
13	High Temperature Storage	Para. 9.21	Initial Measurements Low Level Contact Resistance	Table 2 Item 1	Rcl	Record Values		mΩ
			Final Measurements Low Level Contact Resistance Drift	Table 2 Item 1	ΔRcl	-	4	
			Rated Current Contact Resistance	Table 2 Item 2	Rcr	Table 2 Item 2		
			Contact Retention (In Insert)	Para. 4.3.4 of this spec.	ESCC 3401 Para 9.17			
14	Corrosion	Para. 9.22	Visual Examination	-	-	-	-	
15	Insert Retention (In Shell)	Para. 9.23 & Para. 4.3.6 of this spec.	ESCC 3401/016	-	-	-	-	
16	Jackscrew Retention	Para. 9.24 & Para. 4.3.7 of this spec.	ESCC 3401/016	-	-	-	-	
17	High Temperature Measurements	Para. 9.25	ESCC 3401/016	-	-	-	-	

No.	ESCC Generic Spec. No. 3401		Measurements and Inspections		Symbol	Limits		Unit
	Environmental and Endurance Tests (1)	Test Method and Conditions	Identification	Conditions		Min	Max	
18	Overload Test	Para. 9.26	Rated Current Contact Resistance	Table 2 Item 2	Rcr	Table 2 Item 2		
19	Maintenance Aging	Para. 9.27	Visual Examination Contact Retention (In Insert) Contact Insertion & Withdrawal Forces	- Para. 4.3.4 of this spec. Para. 4.3.8 of this spec.	-	-	-	ESCC 3401 Para. 9.17 Para. 4.3.8 of this spec.
20	Engage/Separation Forces	Para. 9.28 & Para. 4.3.9 of this spec.	Force	-	-	Para. 4.3.9 of this spec.		
21	Oversize Pin Exclusion	Para. 9.29 & Para. 4.3.10 of this spec.	-	-	-	ESCC 3401 Para. 9.29		
22	Probe Damage	Para. 9.30 & Para. 4.3.11 of this spec.	Contact Separation Force	Para. 4.3.9 of this spec.	-	Para. 4.3.9 of this spec.		
23	Solderability	Para. 9.31 & Para. 4.3.12 of this spec.	-	-	-	ESCC 3401 Para. 9.31		

NOTES:

1. The tests in this Table refer to either Chart IV or V and shall be used as applicable.

APPENDIX 'A'
AGREED DEVIATIONS FOR SMITHS INTERCONNECT (F)

ITEMS AFFECTED	DESCRIPTION OF DEVIATIONS
Para. 4.2.4 Deviations from Qualification Tests - Chart IV	Para. 9.27, Maintenance Aging, (a) Procedure, number of cycles: The number of cycles may be reduced from 9 to 5.
Para. 4.2.5 Deviations from Lot Acceptance Tests - Chart V	Para. 9.27, Maintenance Aging, (a) Procedure, number of cycles: The number of cycles may be reduced from 9 to 5.