



**ACCESSORIES FOR CONNECTORS,
MICROMINIATURE 3401/029, 3401/077 AND
CONNECTOR SAVERS 3401/041**

ESCC Detail Specification No. 3401/032

Issue 13	June 2023
----------	-----------



LEGAL DISCLAIMER AND COPYRIGHT

European Space Agency, Copyright © 2023. All rights reserved.

The European Space Agency disclaims any liability or responsibility, to any person or entity, with respect to any loss or damage caused, or alleged to be caused, directly or indirectly by the use and application of this ESCC publication.

This publication, without the prior permission of the European Space Agency and provided that it is not used for a commercial purpose, may be:

- copied in whole, in any medium, without alteration or modification.
- copied in part, in any medium, provided that the ESCC document identification, comprising the ESCC symbol, document number and document issue, is removed.

DOCUMENTATION CHANGE NOTICE

(Refer to <https://escies.org> for ESCC DCR content)

DCR No.	CHANGE DESCRIPTION
1579	Specification upissued to include changes per DCR.

TABLE OF CONTENTS

1	GENERAL	5
1.1	SCOPE	5
1.2	COMPONENT TYPE VARIANTS	5
1.3	MAXIMUM RATINGS	5
1.4	PARAMETER DERATING INFORMATION	5
1.5	PHYSICAL DIMENSIONS	5
1.6	FUNCTIONAL DIAGRAM	5
2	APPLICABLE DOCUMENTS	39
3	TERMS, DEFINITIONS, ABBREVIATIONS, SYMBOLS AND UNITS	40
4	REQUIREMENTS	40
4.1	GENERAL	40
4.2	DEVIATIONS FROM GENERIC SPECIFICATION	40
4.2.1	Deviations from Special In-process Controls	40
4.2.2	Deviations from Final Production Tests (Chart II)	40
4.2.3	Deviations from Burn-in and Electrical Measurements (Chart III)	40
4.2.4	Deviations from Qualification, Environmental and Endurance Tests (Chart IV)	40
4.2.5	Deviations from Lot Acceptance Tests (Chart V)	40
4.3	MECHANICAL REQUIREMENTS	40
4.3.1	Dimension Check	40
4.3.2	Weight	40
4.3.3	Torque Value	40
4.4	MATERIALS AND FINISHES	41
4.4.1	Screw Lock Assemblies and Brackets	41
4.4.2	Interfacial Seals	41
4.5	MARKING	41
4.5.1	General	41
4.5.2	The ESCC Component Number	41
4.5.3	Traceability Information	41
4.6	ELECTRICAL MEASUREMENTS	41
4.7	SCREENING TESTS (TABLES 4 AND 5)	41
4.8	ENVIRONMENTAL AND ENDURANCE TESTS	41

1 GENERAL

1.1 SCOPE

This specification details the ratings, physical and electrical characteristics, test and inspection data of Accessories for Microminiature Connectors [3401/029](#) (Type MDM), Connector Savers [3401/041](#) and Microminiature Connectors with Removable Contacts [3401/077](#) (Type MDMA).

It shall be read in conjunction with:

- ESCC Generic Specification No. [3401](#), Connectors, Electrical, Circular and Rectangular.
- ESCC Detail Specification No. [3401/029](#), Connectors, Electrical, Rectangular, Microminiature, based on Type MDM.
- ESCC Detail Specification No. [3401/041](#), Connector Savers, Electrical, Rectangular, Microminiature, based on type MDM.
- ESCC Detail Specification No. [3401/077](#), Connectors, Electrical, Rectangular, Microminiature, Removable Contacts, based on type MDMA.
- ESCC Detail Specification No. [3401/087](#), Lightweight Accessories for Rectangular, Microminiature Connectors, [3401/029](#) and [3401/077](#)

the requirements of which are supplemented herein.

1.2 COMPONENT TYPE VARIANTS

The type variants of accessories covered by this specification are given in Table 1(a).

1.3 MAXIMUM RATINGS

The maximum ratings, which shall not be exceeded at any time during use or storage, applicable to the accessories specified herein, are as scheduled in Table 1(b).

1.4 PARAMETER DERATING INFORMATION

Not applicable.

1.5 PHYSICAL DIMENSIONS

The physical dimensions of the accessories specified herein are shown in Figure 2.

1.6 FUNCTIONAL DIAGRAM

Not applicable.

TABLE 1(a) – TYPE VARIANTS

Variant	Description (1)	For Use With (2)
03	90° Mounting Bracket, Shell Size 9 to 37	ESCC 3401/029 Variants 01, 02 ESCC 3401/077 Variants 01, 02
04	90° Mounting Bracket, Shell Size 51, 69	ESCC 3401/029 Variants 01, 02
07	Screw Sub-Assembly, Slot Head, Shell Size 9 to 69	ESCC 3401/029 Variants 01, 02 ESCC 3401/077 Variants 01, 02
08	Screwlock Sub-Assembly (Front Panel Mounting) with Nut and Lock-Washer, Shell Size 9 to 69	ESCC 3401/029 Variants 01, 02 ESCC 3401/077 Variants 01, 02
09	Screwlock Sub-Assembly (Rear Panel Mounting) with Nut and Lock-Washer, Shell Size 9 to 69, Panel Thickness 1.6mm	ESCC 3401/029 Variants 01, 02 ESCC 3401/077 Variants 01, 02
10	Screwlock Assembly for Connector Savers, Shell Size 9 to 69	ESCC 3401/041 Variants 01 to 08
11	Screwlock for Connectors FR136, FR139, Shell Size 9 to 51	ESCC 3401/029 Variants 01, 02
12	Interfacial Seals for MDMA Female Connectors, Shell Size 9	ESCC 3401/077 Variants 01, 02
13	Interfacial Seals for MDMA Female Connectors, Shell Size 15	ESCC 3401/077 Variants 01, 02
14	Interfacial Seals for MDMA Female Connectors, Shell Size 21	ESCC 3401/077 Variants 01, 02
15	Interfacial Seals for MDMA Female Connectors, Shell Size 25	ESCC 3401/077 Variants 01, 02
16	Interfacial Seals for MDMA Female Connectors, Shell Size 31	ESCC 3401/077 Variants 01, 02
17	Interfacial Seals for MDMA Female Connectors, Shell Size 37	ESCC 3401/077 Variants 01, 02
18	Screw Sub-Assembly for Lightweight Backshell, Slot Head, Shell Size 9 to 69	ESCC 3401/087 All Variants for the specified Shell Sizes
19	Interfacial Seals for MDMA Female Connectors, Shell Size 51	ESCC 3401/077 Variants 01, 02
20	Screwlock Sub-Assembly (Front Panel Mounting) with Self-Locking Nut, Shell Size 9 to 69	ESCC 3401/029 Variants 01, 02 ESCC 3401/077 Variants 01, 02
21	Screwlock Sub-Assembly (Rear Panel Mounting) with Self-Locking Nut, Shell Size 9 to 69, Panel Thickness 1.6mm	ESCC 3401/029 Variants 01, 02 ESCC 3401/077 Variants 01, 02
22	Screw Sub-Assembly, Shell Size 9 to 69, Hex. Hole Head	ESCC 3401/029 Variants 01, 02 ESCC 3401/077 Variants 01, 02
23	Screwlock Sub-Assembly (Rear Panel Mounting) with Nut and Lock-Washer, Shell Size 9 to 69, Panel Thickness 0.8mm	ESCC 3401/029 Variants 01, 02 ESCC 3401/077 Variants 01, 02
24	Screwlock Sub-Assembly (Rear Panel Mounting) with Nut and Lock-Washer, Shell Size 9 to 69, Panel Thickness 1.2mm	ESCC 3401/029 Variants 01, 02 ESCC 3401/077 Variants 01, 02
25	Screwlock Sub-Assembly (Rear Panel Mounting) with Nut and Lock-Washer, Shell Size 9 to 69, Panel Thickness 2mm	ESCC 3401/029 Variants 01, 02 ESCC 3401/077 Variants 01, 02
26	Screwlock Sub-Assembly (Rear Panel Mounting) with Nut and Lock-Washer, Shell Size 9 to 69, Panel Thickness 2.4mm	ESCC 3401/029 Variants 01, 02 ESCC 3401/077 Variants 01, 02
27	Screwlock for Connectors 75SBT, Shell Size 9 to 69	ESCC 3401/029 Variants 01, 02
28	Screwlock for Connectors 75SBT (Rear Panel Mounting), Shell Size 9 to 69, Panel Thickness 0.8mm	ESCC 3401/029 Variants 01, 02
29	Screwlock for Connectors 75SBT (Rear Panel Mounting), Shell Size 9 to 69, Panel Thickness 1.2mm	ESCC 3401/029 Variants 01, 02
30	Screwlock for Connectors 75SBT (Rear Panel Mounting), Shell Size 9 to 69, Panel Thickness 1.6mm	ESCC 3401/029 Variants 01, 02
31	Screwlock for Connectors 75SBT (Rear Panel Mounting), Shell Size 9 to 69, Panel Thickness 2mm	ESCC 3401/029 Variants 01, 02
32	Screwlock for Connectors 75SBT (Rear Panel Mounting), Shell Size 9 to 69, Panel Thickness 2.4mm	ESCC 3401/029 Variants 01, 02

Variant	Description (1)	For Use With (2)
33	Screwlock for Connectors 75RB/CBR, Shell Size 9 to 51	ESCC 3401/029 Variants 01, 02
34	Screwlock for Connectors 75RB/CBR (Rear Panel Mounting), Shell Size 9 to 51, Panel Thickness 0.8mm	ESCC 3401/029 Variants 01, 02
35	Screwlock for Connectors 75RB/CBR (Rear Panel Mounting), Shell Size 9 to 51, Panel Thickness 1.2mm	ESCC 3401/029 Variants 01, 02
36	Screwlock for Connectors 75RB/CBR (Rear Panel Mounting), Shell Size 9 to 51, Panel Thickness 1.6mm	ESCC 3401/029 Variants 01, 02
37	Screwlock for Connectors 75RB/CBR (Rear Panel Mounting), Shell Size 9 to 51, Panel Thickness 2mm	ESCC 3401/029 Variants 01, 02
38	Screwlock for Connectors 75RB/CBR (Rear Panel Mounting), Shell Size 9 to 51, Panel Thickness 2.4mm	ESCC 3401/029 Variants 01, 02
39	Screw Sub-Assembly, Slot Head, Shell Size 100	ESCC 3401/029 Variants 01, 02
40	Screw Sub-Assembly, Hex. Hole Head, Shell Size 100	ESCC 3401/029 Variants 01, 02
41	Screwlock Assembly for Connector Savers, Shell Size 100	ESCC 3401/041 Variant 09
42	Screwlock for Connectors GMR7580, GMR7590, Shell Size 9 to 69	ESCC 3401/029 Variants 01, 02
43	Screwlock for Connectors GMR7580, GMR7590, Shell Size 100	ESCC 3401/029 Variants 01, 02
44	Screw Sub-Assembly for Lightweight Backshell, Hex. Hole Head, Shell Size 9 to 69	ESCC 3401/087 All applicable Variants
45	Screw Sub-Assembly for Lightweight Backshell, Slot Head, Shell Size 100	ESCC 3401/087 All Variants for the specified Shell Size
46	Screw Sub-Assembly for Lightweight Backshell, Hex. Hole Head, Shell Size 100	ESCC 3401/087 All Variants for the specified Shell Size
47	Screwlock Sub-Assembly (Front Panel Mounting) with Nut and Split Ring, Shell Size 9 to 69	ESCC 3401/029 Variants 01, 02
48	Screwlock Sub-Assembly (Front Panel Mounting) with Nut and Split Ring, Shell Size 100	ESCC 3401/029 Variants 01, 02
49	Screwlock Sub-Assembly (Rear Panel Mounting) with Nut and Split Ring, Shell Size 9 to 69, Panel Thickness 0.8mm	ESCC 3401/029 Variants 01, 02
50	Screwlock Sub-Assembly (Rear Panel Mounting) with Nut and Split Ring, Shell Size 9 to 69, Panel Thickness 1.2mm	ESCC 3401/029 Variants 01, 02
51	Screwlock Sub-Assembly (Rear Panel Mounting) with Nut and Split Ring, Shell Size 9 to 69, Panel Thickness 1.6mm	ESCC 3401/029 Variants 01, 02
52	Screwlock Sub-Assembly (Rear Panel Mounting) with Nut and Split Ring, Shell Size 9 to 69, Panel Thickness 2mm	ESCC 3401/029 Variants 01, 02
53	Screwlock Sub-Assembly (Rear Panel Mounting) with Nut and Split Ring, Shell Size 9 to 69, Panel Thickness 2.4mm	ESCC 3401/029 Variants 01, 02
54	Screwlock Sub-Assembly (Rear Panel Mounting) with Nut and Split Ring, Shell Size 100, Panel Thickness 0.8mm	ESCC 3401/029 Variants 01, 02
55	Screwlock Sub-Assembly (Rear Panel Mounting) with Nut and Split Ring, Shell Size 100, Panel Thickness 1.2mm	ESCC 3401/029 Variants 01, 02
56	Screwlock Sub-Assembly (Rear Panel Mounting) with Nut and Split Ring, Shell Size 100, Panel Thickness 1.6mm	ESCC 3401/029 Variants 01, 02
57	Screwlock Sub-Assembly (Rear Panel Mounting) with Nut and Split Ring, Shell Size 100, Panel Thickness 2mm	ESCC 3401/029 Variants 01, 02
58	Screwlock Sub-Assembly (Rear Panel Mounting) with Nut and Split Ring, Shell Size 100, Panel Thickness 2.4mm	ESCC 3401/029 Variants 01, 02

Variant	Description (1)	For Use With (2)
59	Screwlock for Connectors GMR7580, GMR7590 (Rear Panel Mounting), Shell Size 9 to 69, Panel Thickness 0.8mm	ESCC 3401/029 Variants 01, 02
60	Screwlock for Connectors GMR7580, GMR7590 (Rear Panel Mounting), Shell Size 9 to 69, Panel Thickness 1.2mm	ESCC 3401/029 Variants 01, 02
61	Screwlock for Connectors GMR7580, GMR7590 (Rear Panel Mounting), Shell Size 9 to 69, Panel Thickness 1.6mm	ESCC 3401/029 Variants 01, 02
62	Screwlock for Connectors GMR7580, GMR7590 (Rear Panel Mounting), Shell Size 9 to 69, Panel Thickness 2mm	ESCC 3401/029 Variants 01, 02
63	Screwlock for Connectors GMR7580, GMR7590 (Rear Panel Mounting), Shell Size 9 to 69, Panel Thickness 2.4mm	ESCC 3401/029 Variants 01, 02
64	Screwlock for Connectors GMR7580, GMR7590 (Rear Panel Mounting), Shell Size 100, Panel Thickness 0.8mm	ESCC 3401/029 Variants 01, 02
65	Screwlock for Connectors GMR7580, GMR7590 (Rear Panel Mounting), Shell Size 100, Panel Thickness 1.2mm	ESCC 3401/029 Variants 01, 02
66	Screwlock for Connectors GMR7580, GMR7590 (Rear Panel Mounting), Shell Size 100, Panel Thickness 1.6mm	ESCC 3401/029 Variants 01, 02
67	Screwlock for Connectors GMR7580, GMR7590 (Rear Panel Mounting), Shell Size 100, Panel Thickness 2mm	ESCC 3401/029 Variants 01, 02
68	Screwlock for Connectors GMR7580, GMR7590 (Rear Panel Mounting), Shell Size 100, Panel Thickness 2.4mm	ESCC 3401/029 Variants 01, 02

NOTES:

1. See Figure 2 for details.
2. The applicable shell sizes are the same as given in the description column (if specified in the referenced specification).

TABLE 1(b) - MAXIMUM RATINGS

No.	Characteristics	Symbol	Maximum Ratings	Unit
1	Operating Temperature Range	T _{op}	-55 to +125	°C
2	Storage Temperature Range	T _{stg}	-55 to +125	°C
3	Torque Value	T	See Figure 2	Nm

FIGURE 1

Not applicable.

FIGURE 2 - PHYSICAL DIMENSIONS

VARIANTS 03 & 04 - 90° MOUNTING BRACKET (FOR SHELL SIZE 9 TO 69)

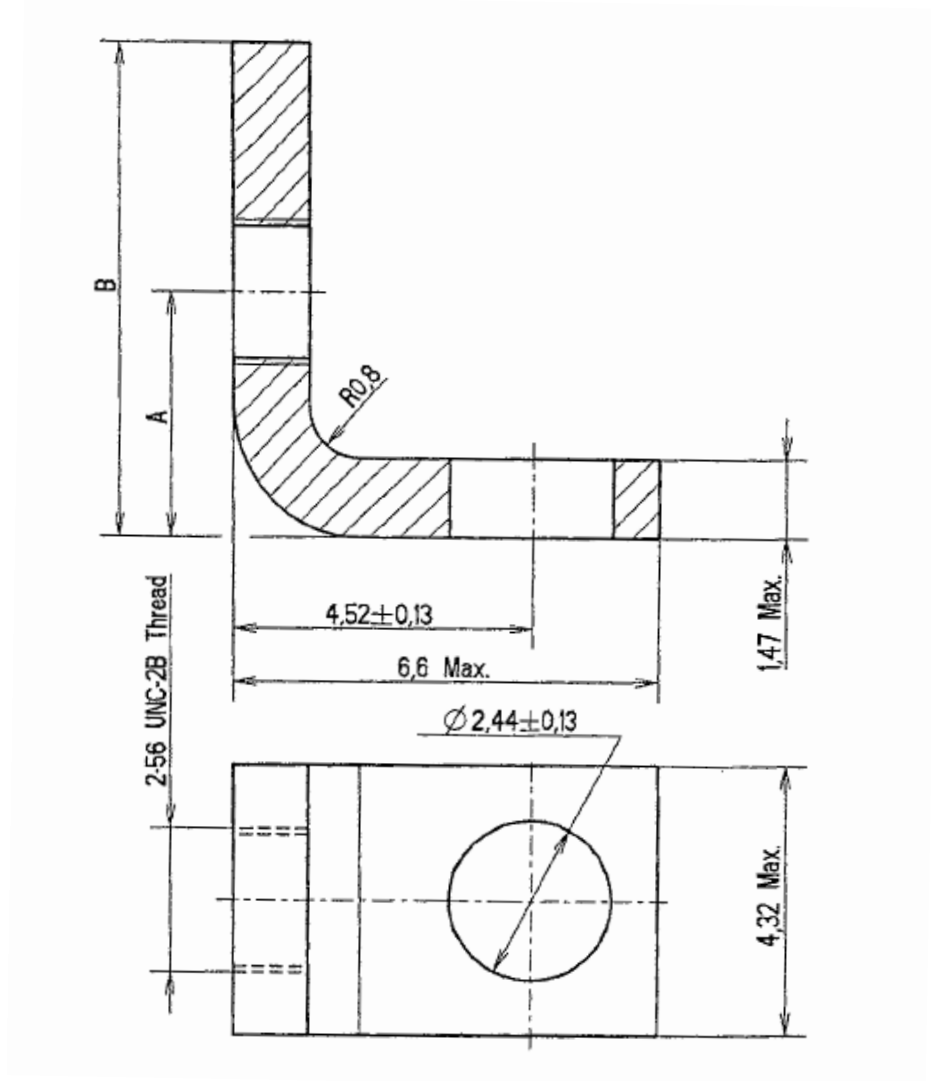

Variant	Shell Size	A ±0.13	B Max
03	9 to 37	3.73	7.82
04	51, 69	4.29	8.89

NOTES:

1. All dimensions in mm.
2. Weight:
 - Variant 03 0.42g
 - Variant 04 0.45g

VARIANT 07 - SCREW SUB-ASSEMBLY, SLOT HEAD (FOR SHELL SIZE 9 TO 69)

Screw

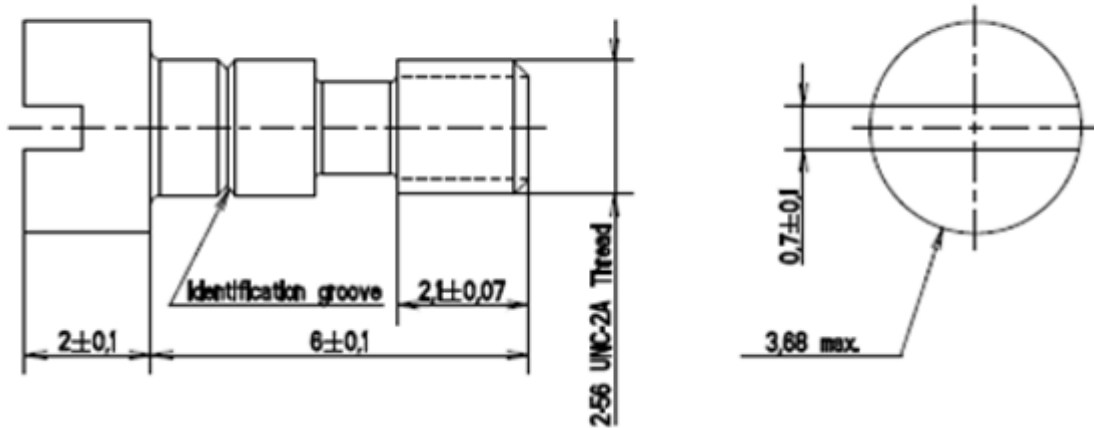

Clip

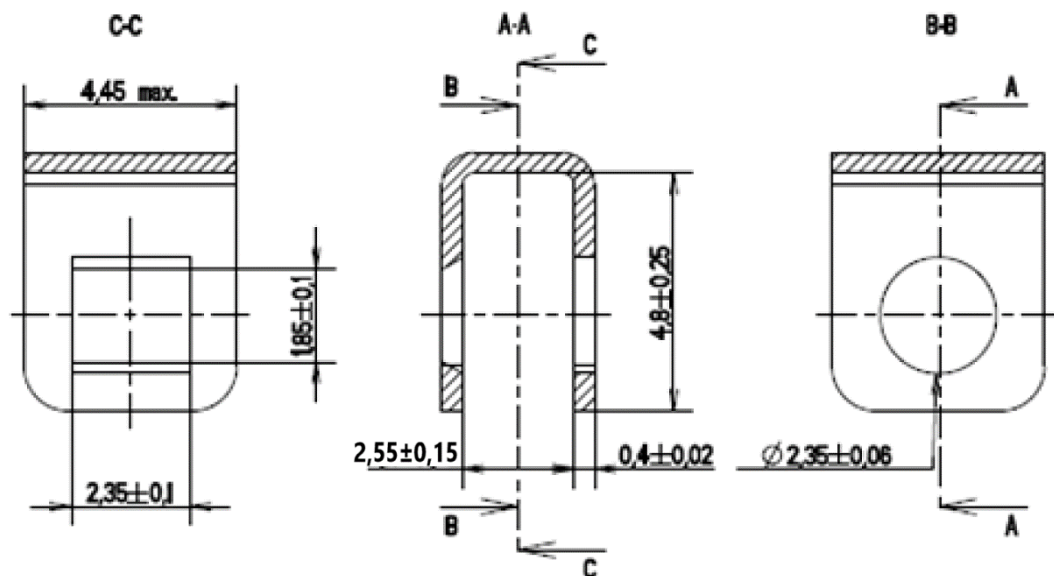

NOTES:

1. All dimensions in mm.
2. Weight:
 - Screw 0.3g
 - Clip 0.14g
- 3.

Torque Values	Min (Nm)	Max (Nm)
Screw	0.28	0.32

VARIANT 08 - SCREWLOCK SUB-ASSEMBLY (FRONT PANEL MOUNTING) WITH NUT AND LOCK-WASHER (FOR SHELL SIZE 9 TO 69)

Screwlock

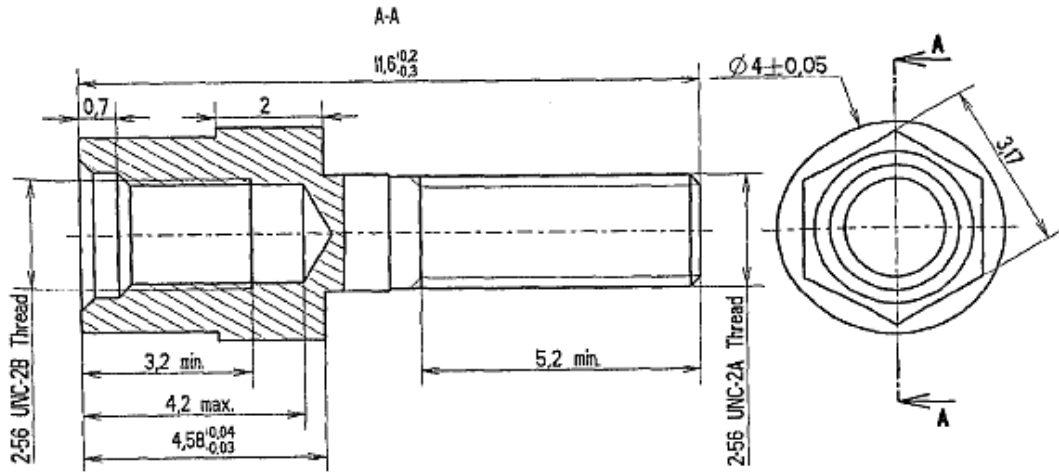

Nut

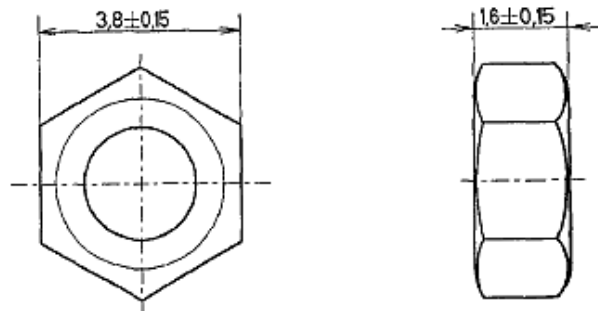

Lock-Washer

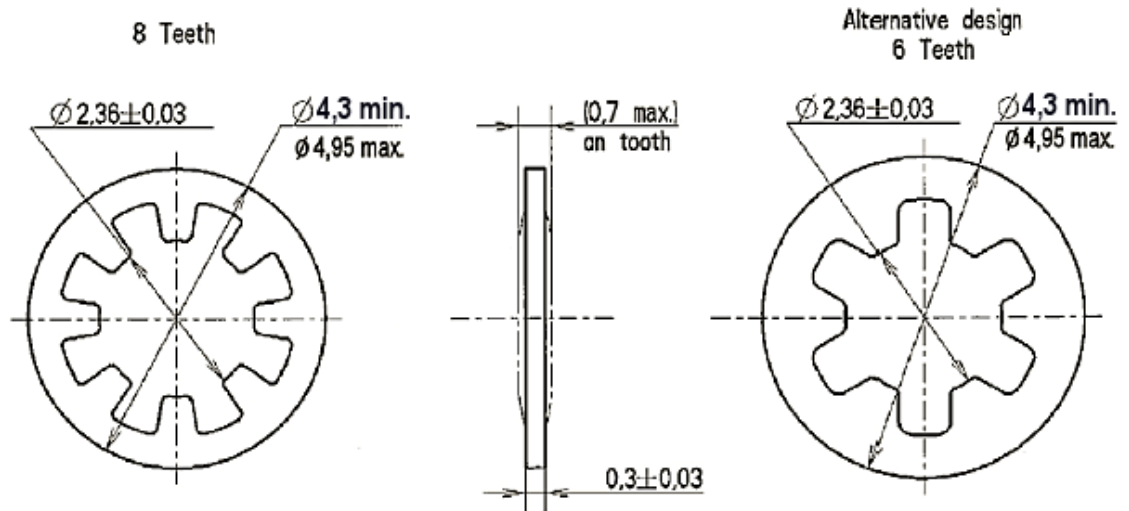

NOTES:

1. All dimensions in mm.
2. Weight:
 - Screwlock 0.51g
 - Nut 0.13g
 - Lock-Washer 0.02g
- 3.

Torque Values	Min (Nm)	Max (Nm)
Screwlock male side	0.44	0.48
Screwlock female side	0.28	0.32
Nut	0.44	0.48

VARIANTS 09 & 23 TO 26 - SCREWLOCK SUB-ASSEMBLY (REAR PANEL MOUNTING) WITH NUT AND LOCK-WASHER (FOR SHELL SIZE 9 TO 69) PANEL THICKNESS 0.8 TO 2.4mm

Screwlock

Variant	23	24	09	25	26
Panel Thickness (+0.2 -0)	0.8	1.2	1.6	2	2.4
Dimension A	0.7	1.1	1.5	1.9	2.3

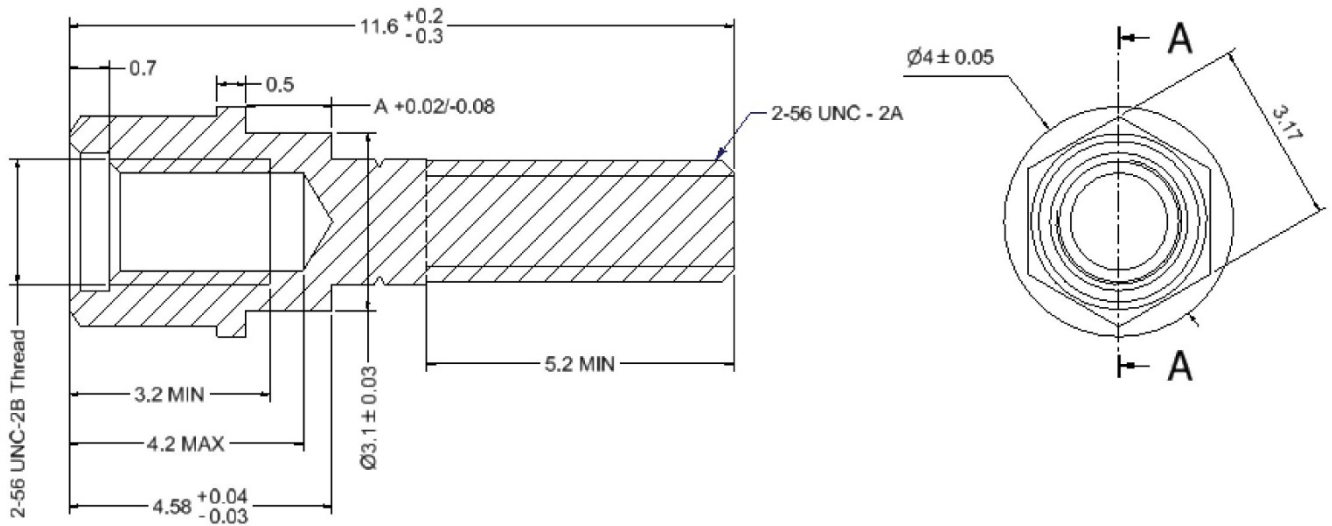

Nut

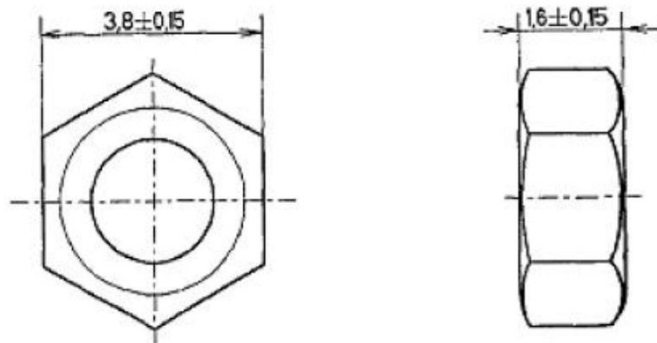

Lock-Washer

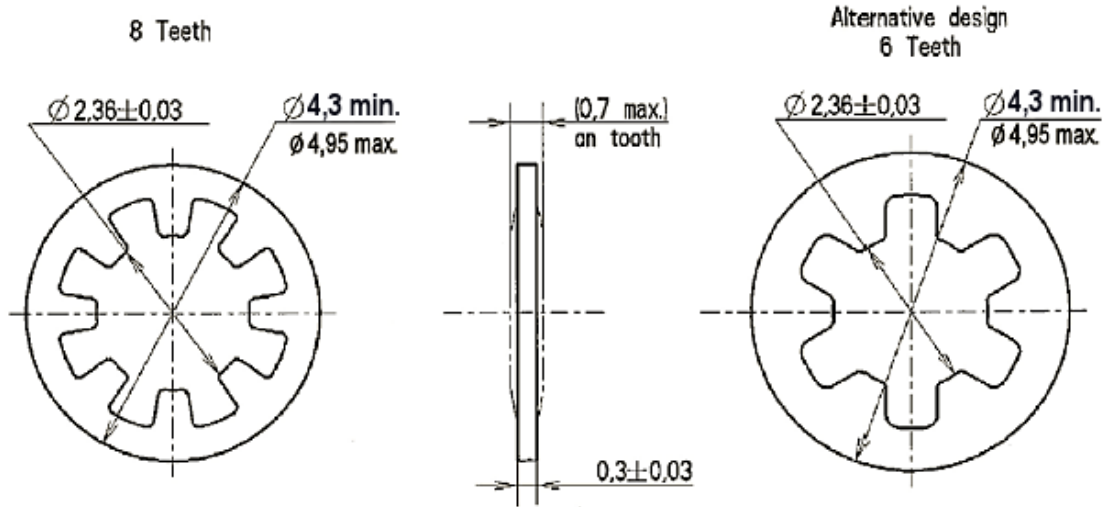

NOTES:

1. All dimensions in mm.
2. Weight:
 - Screwlock 0.45g
 - Nut 0.13g
 - Lock-Washer 0.02g
- 3.

Torque Values	Min (Nm)	Max (Nm)
Screwlock male side	0.44	0.48
Screwlock female side	0.28	0.32
Nut	0.44	0.48

**VARIANT 10 - SCREWLOCK ASSEMBLY FOR CONNECTOR SAVERS
(FOR SHELL SIZE 9 TO 69)**

Screwlock

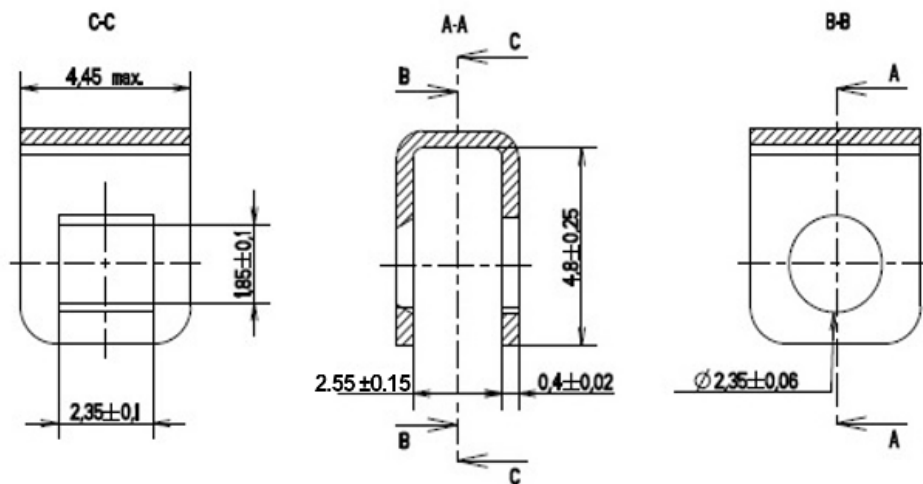
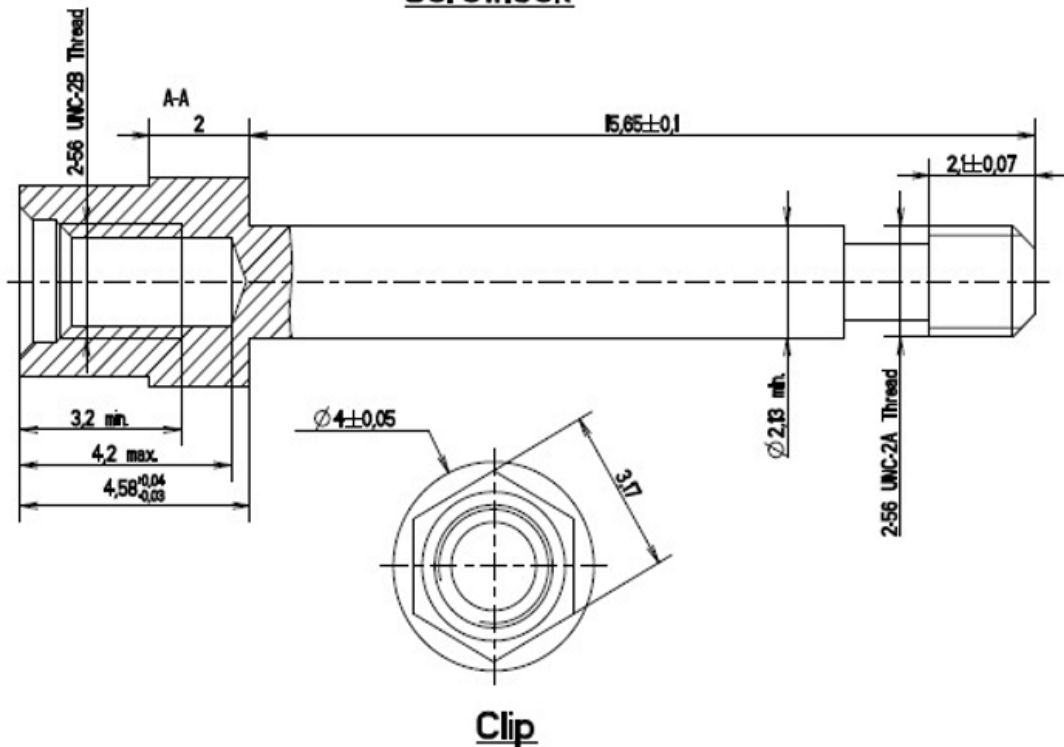

NOTES:

1. All dimensions in mm.
2. Weight:
 - Screwlock 0.79g
 - Clip 0.14g
- 3.

Torque Values	Min (Nm)	Max (Nm)
Screwlock male side	0.36	0.4
Screwlock female side	0.28	0.32

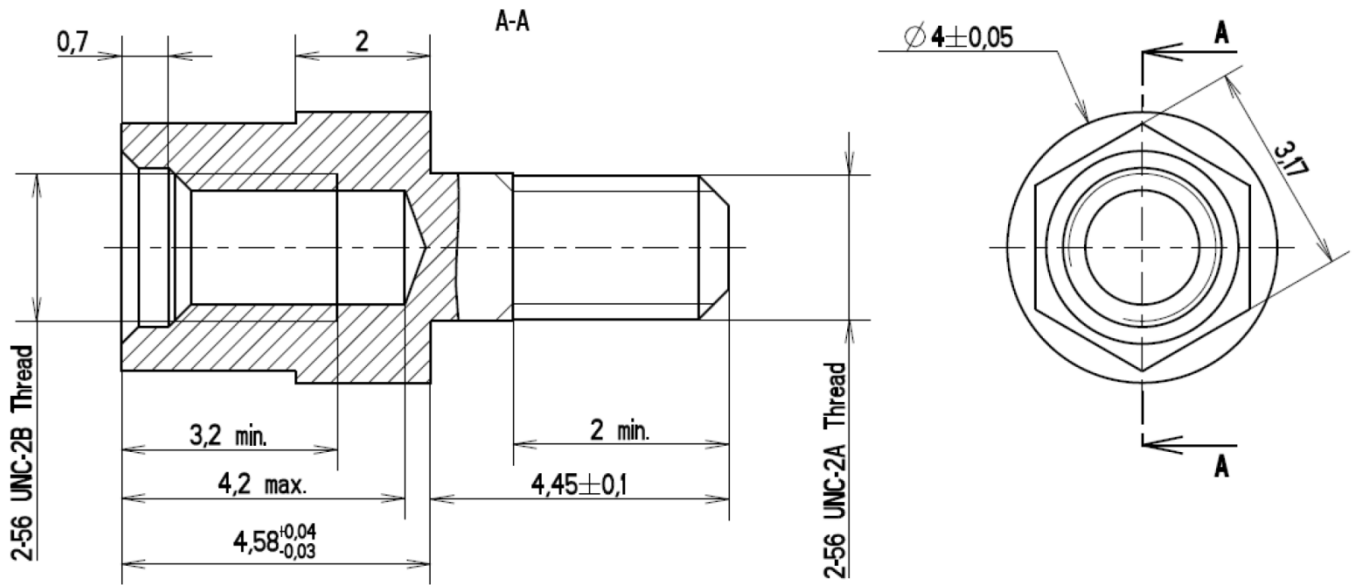
VARIANT 11 - SCREWLOCK FOR CONNECTORS FR136, FR139 (FOR SHELL SIZE 9 TO 51)

NOTES:

1. All dimensions in mm.
2. Weight:
 - Screwlock 0.43g
- 3.

Torque Values	Min (Nm)	Max (Nm)
Screwlock male side	0.44	0.48
Screwlock female side	0.28	0.32

VARIANTS 12 TO 17 & 19 - INTERFACIAL SEALS FOR MDMA FEMALE CONNECTORS
 (PER ESCC [3401/077](#) VARIANTS 01, 02)

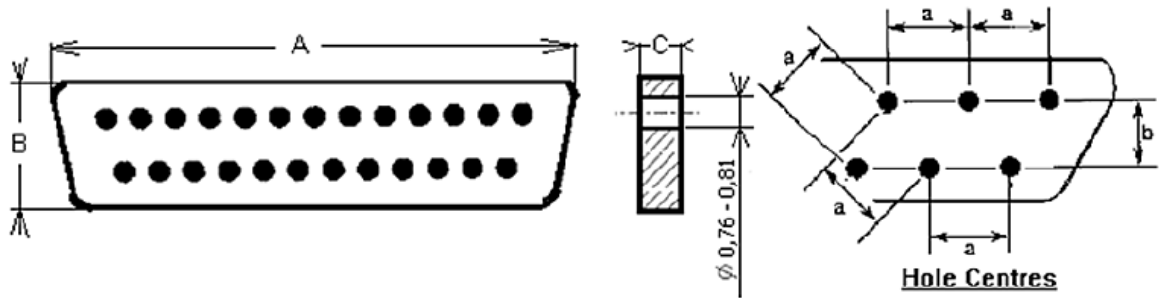
VARIANT 15 (SHELL SIZE 25) SHOWN FOR ILLUSTRATIVE PURPOSES



Variant	Shell Size	Dimensions (mm)						Weight Max. (g)
		A		B		C		
		Min	Max	Min	Max	Min	Max	
12	9	8.33	8.73	4.6	4.8	0.6	0.7	0.02
13	15	12.14	12.54	4.6	4.8	0.6	0.7	0.03
14	21	15.95	16.35	4.6	4.8	0.6	0.7	0.04
15	25	18.49	18.89	4.6	4.8	0.6	0.7	0.05
16	31	22.3	22.7	4.6	4.8	0.6	0.7	0.07
17	37	26.11	26.51	4.6	4.8	0.6	0.7	0.08
19	51	24.84	25.24	5.7	5.9	0.6	0.7	0.09

NOTES:

1. a = Distance between hole centres: 1.27mm typical.
2. b = Distance between rows: 1.09mm typical.

**VARIANT 18 – SCREW SUB-ASSEMBLY FOR LIGHTWEIGHT BACKSHELL, SLOT HEAD
(FOR SHELL SIZE 9 TO 69)**

Screw

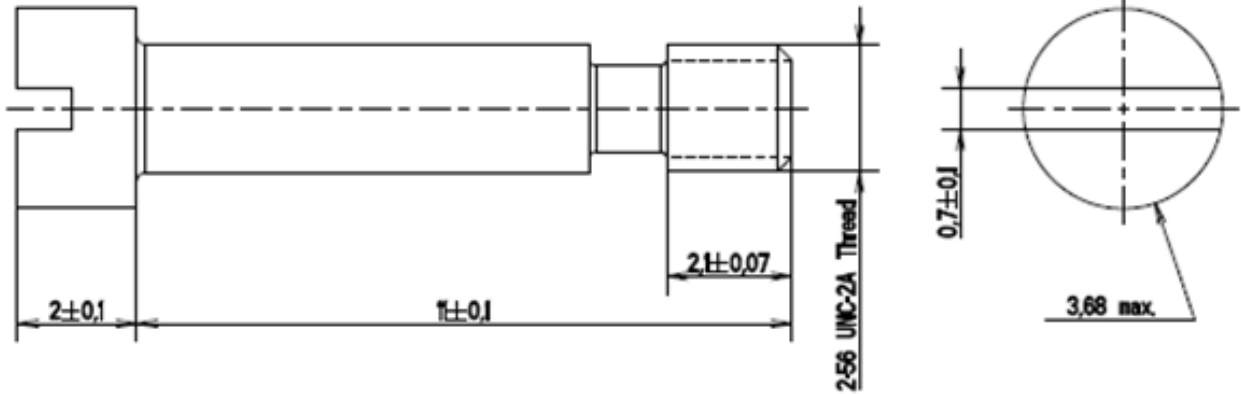

Clip

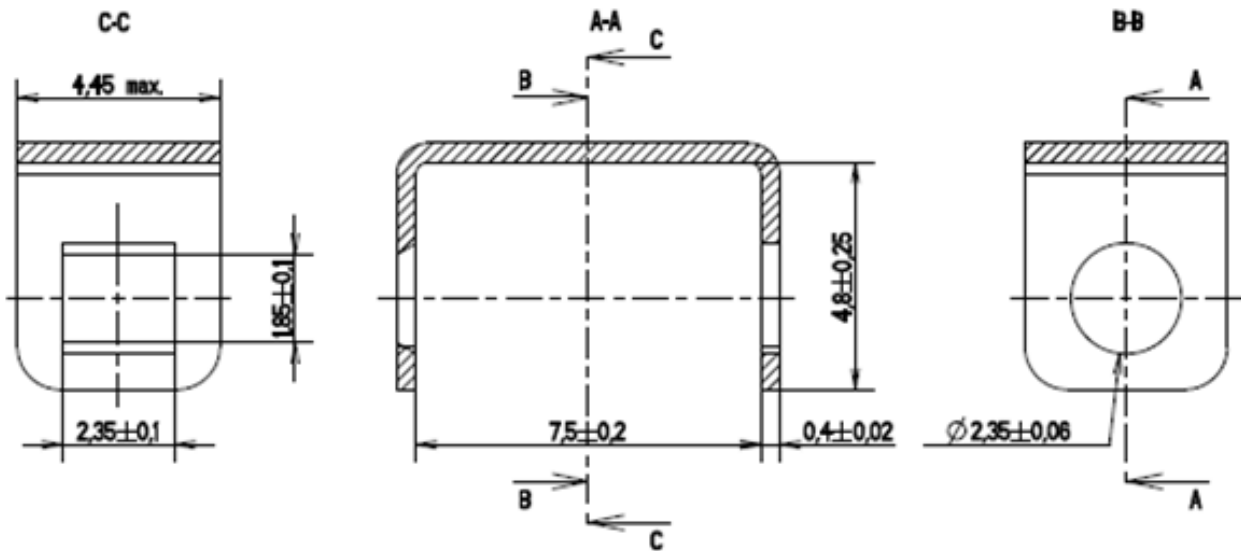

NOTES:

1. All dimensions in mm.
2. Weight:
 - Screw 0.6g
 - Clip 0.2g
- 3.

Torque Values	Min (Nm)	Max (Nm)
Screw	0.28	0.32

VARIANT 20 - SCREWLOCK SUB-ASSEMBLY (FRONT PANEL MOUNTING) WITH
SELF-LOCKING NUT (FOR SHELL SIZE 9 TO 69)

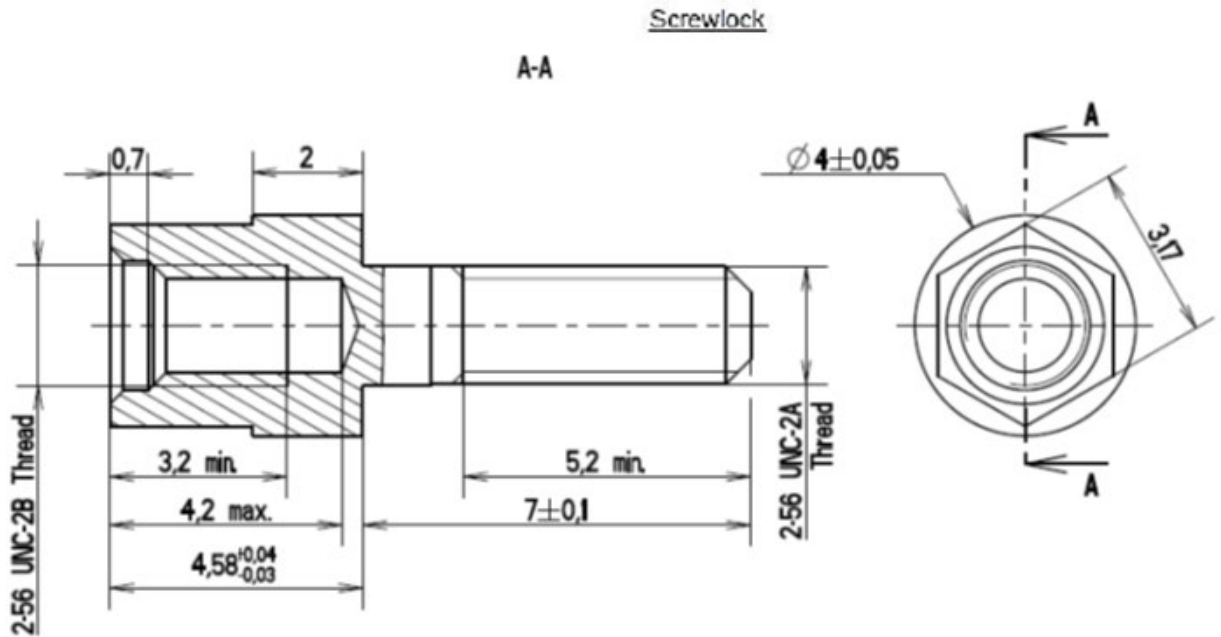

Self-locking nut

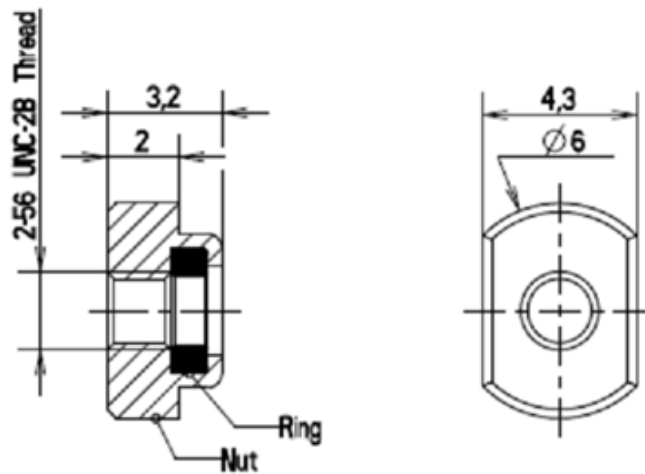

NOTES:

1. All dimensions in mm.
2. Weight:
 - Screwlock 0.51g
 - Self-locking Nut 0.4 g
- 3.

Torque Values	Min (Nm)	Max (Nm)
Screwlock male side	0.44	0.48
Screwlock female side	0.28	0.32
Self-locking Nut	0.44	0.48

VARIANT 21 - SCREWLOCK SUB-ASSEMBLY (REAR PANEL MOUNTING) WITH
SELF-LOCKING NUT (FOR SHELL SIZE 9 TO 69) PANEL THICKNESS 1.6mm

Screwlock

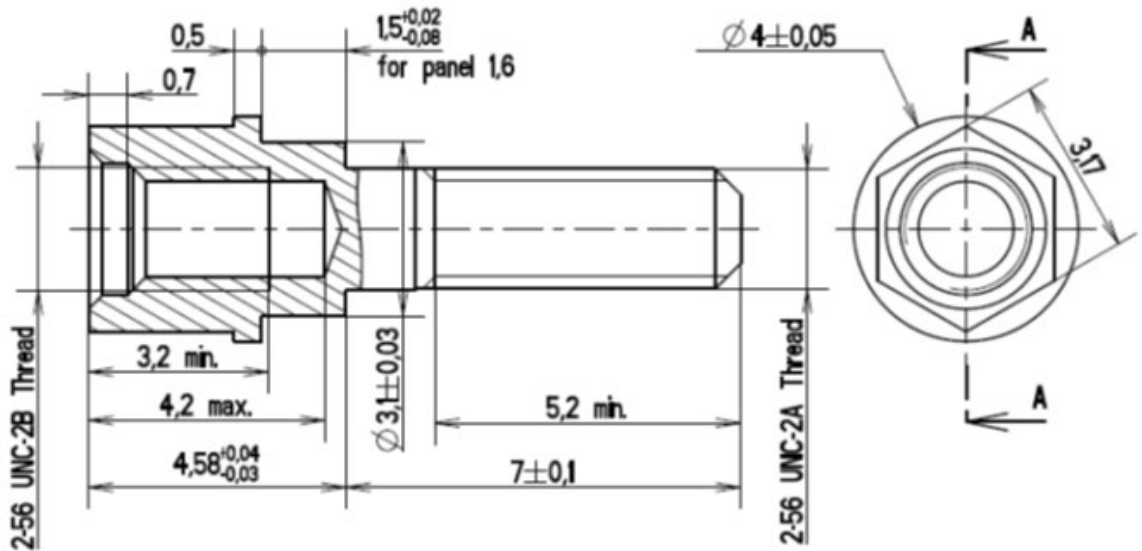

Self-locking nut

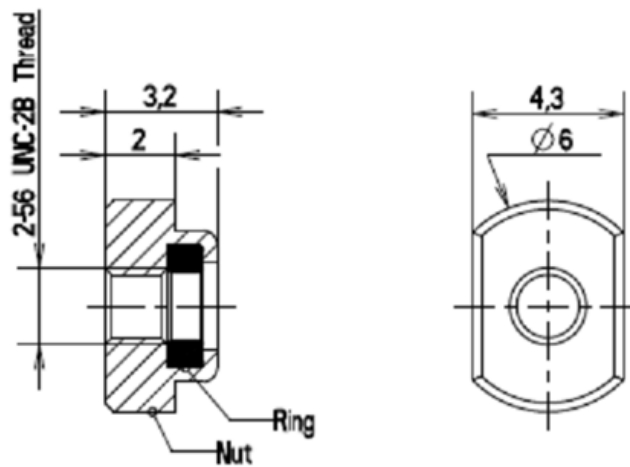

NOTES:

1. All dimensions in mm.
2. Weight:
 - Screwlock 0.45g
 - Self-Locking Nut 0.4 g
- 3.

Torque Values	Min (Nm)	Max (Nm)
Screwlock male side	0.44	0.48
Screwlock female side	0.28	0.32
Self-locking Nut	0.44	0.48

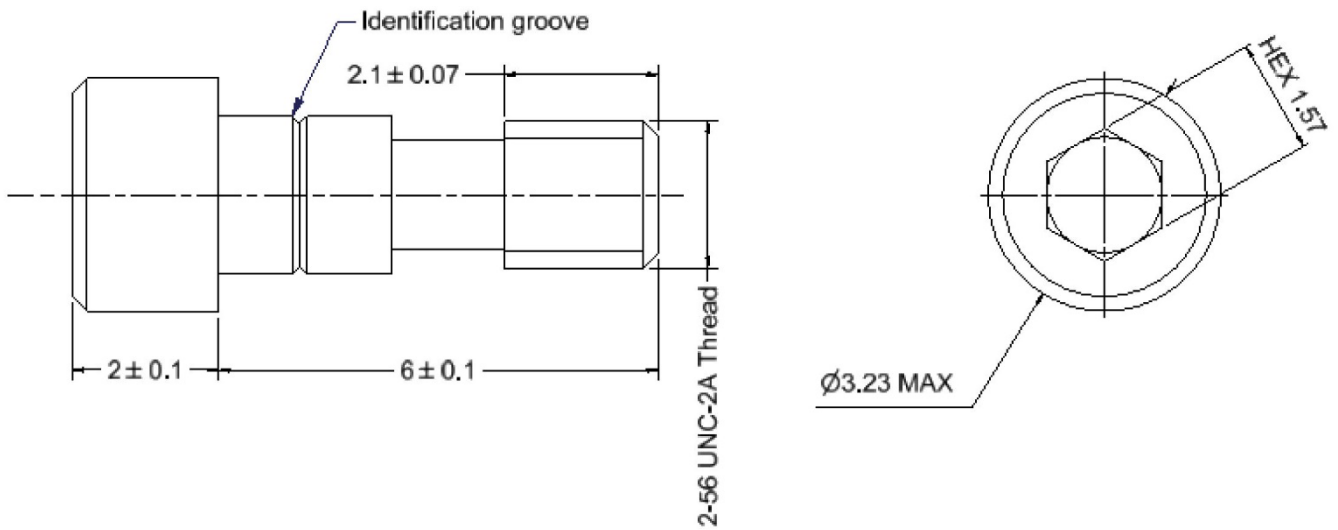
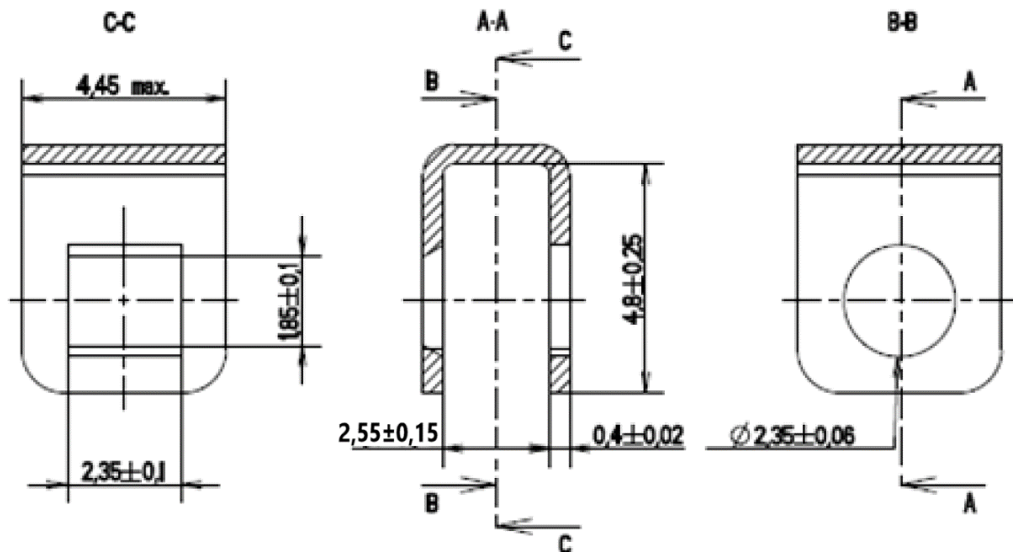
VARIANT 22 – SCREW SUB-ASSEMBLY (FOR SHELL SIZE 9 TO 69) HEX. HOLE HEAD
Screw

Clip

NOTES:

1. All dimensions in mm.
2. Weight:
 - Screw 0.3g
 - Clip 0.14g
- 3.

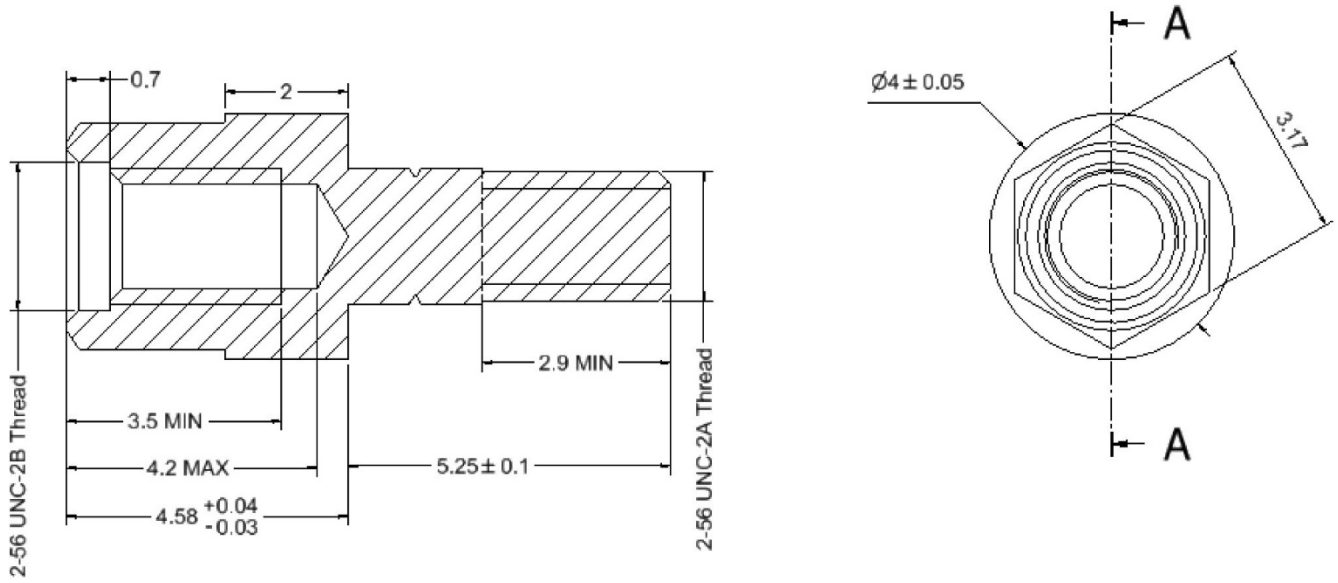
Torque Values	Min (Nm)	Max (Nm)
Screw	0.28	0.32

VARIANT 27 – SCREWLOCK FOR CONNECTORS 75SBT (FOR SHELL SIZE 9 TO 69)



NOTES:

1. All dimensions in mm.
2. Weight:
 - Screwlock 0.43g
- 3.

Torque Values	Min (Nm)	Max (Nm)
Screwlock male side	0.44	0.48
Screwlock female side	0.28	0.32

**VARIANTS 28 TO 32 – SCREWLOCK FOR CONNECTORS 75SBT (REAR PANEL MOUNT)
(FOR SHELL SIZE 9 TO 69) PANEL THICKNESS 0.8 TO 2.4mm**

Variant	28	29	30	31	32
Panel Thickness (+0.2 -0)	0.8	1.2	1.6	2	2.4
Dimension A	0.7	1.1	1.5	1.9	2.3

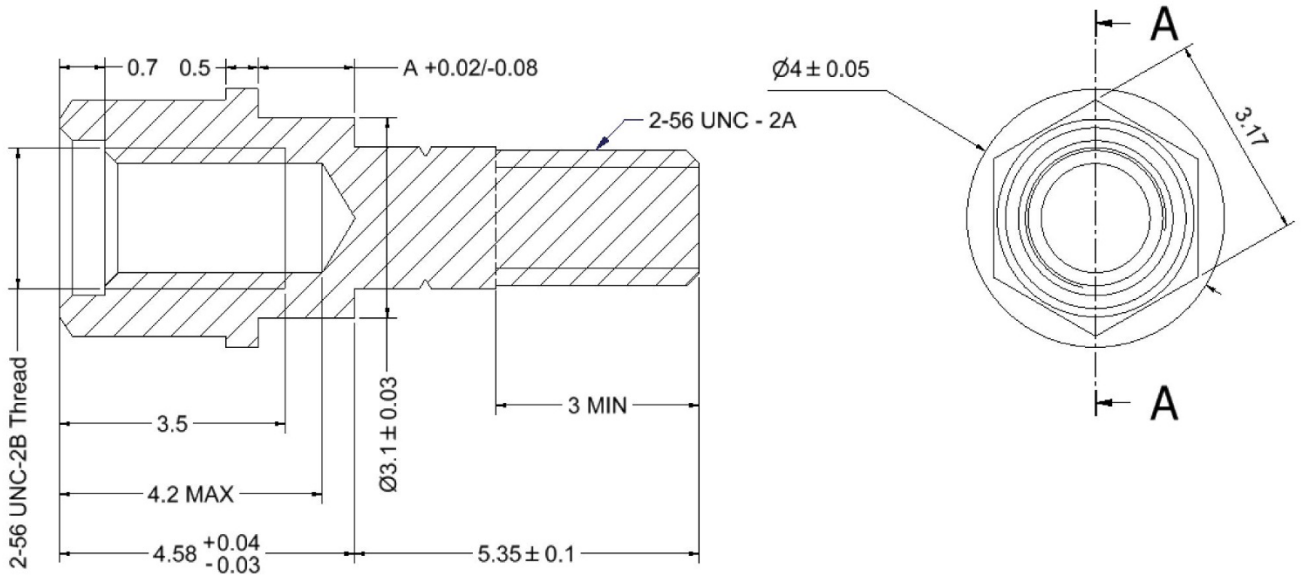

NOTES:

1. All dimensions in mm.
2. Weight:
 - Screwlock 0.43g
- 3.

Torque Values	Min (Nm)	Max (Nm)
Screwlock male side	0.44	0.48
Screwlock female side	0.28	0.32

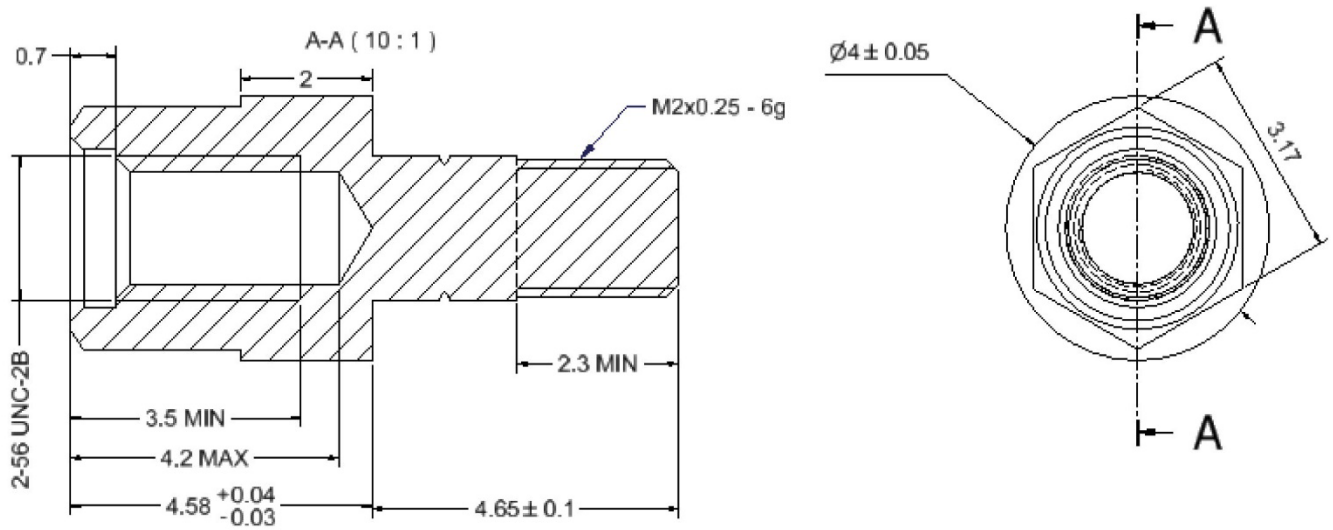
VARIANT 33 – SCREWLOCK FOR CONNECTORS 75RB/CBR (FOR SHELL SIZE 9 TO 51)

NOTES:

1. All dimensions in mm.
2. Weight:
 - Screwlock 0.43g
- 3.

Torque Values	Min (Nm)	Max (Nm)
Screwlock male side	0.44	0.48
Screwlock female side	0.28	0.32

**VARIANTS 34 TO 38 – SCREWLOCK FOR CONNECTORS 75RB/CBR (REAR PANEL MOUNT)
(FOR SHELL SIZES 9 TO 51) PANEL THICKNESS 0.8 TO 2.4mm**

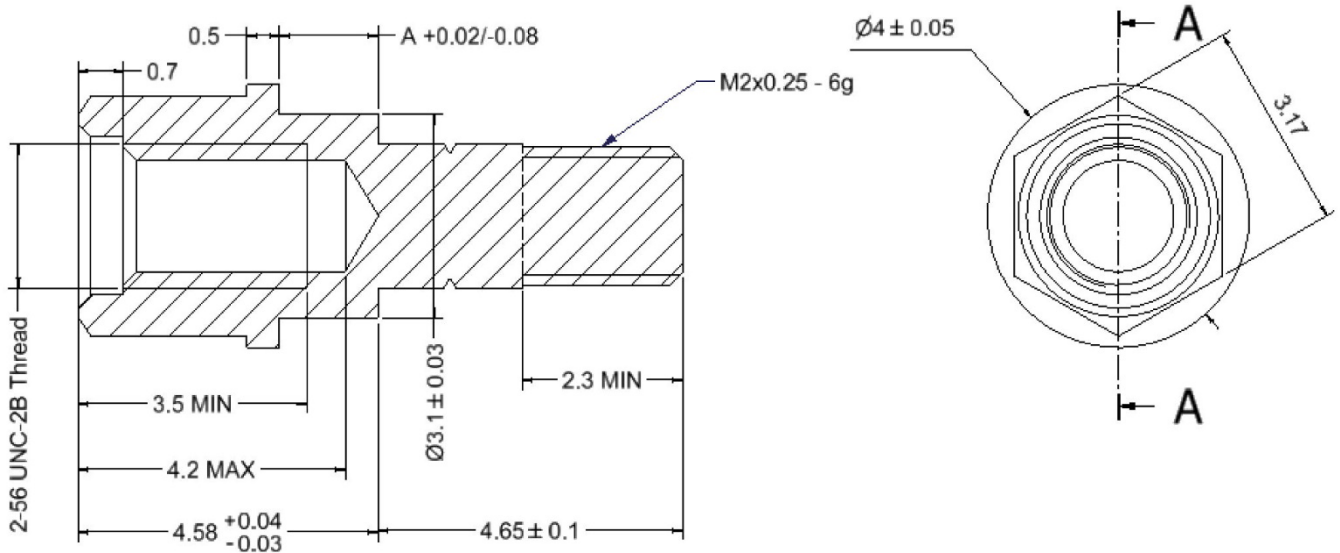
Variant	34	35	36	37	38
Panel Thickness (+0.2 -0)	0.8	1.2	1.6	2	2.4
Dimension A	0.7	1.1	1.5	1.9	2.3



NOTES:

1. All dimensions in mm.
2. Weight:
 - Screwlock 0.43g
- 3.

Torque Values	Min (Nm)	Max (Nm)
Screwlock male side	0.44	0.48
Screwlock female side	0.28	0.32

VARIANT 39 - SCREW SUB-ASSEMBLY, SLOT HEAD (FOR SHELL SIZE 100)

Screw

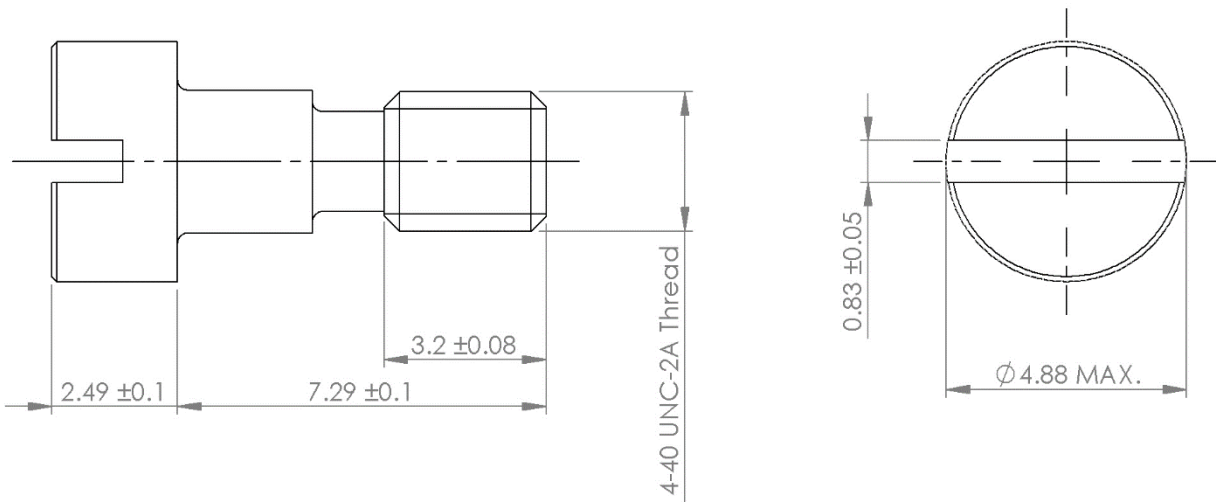

Clip

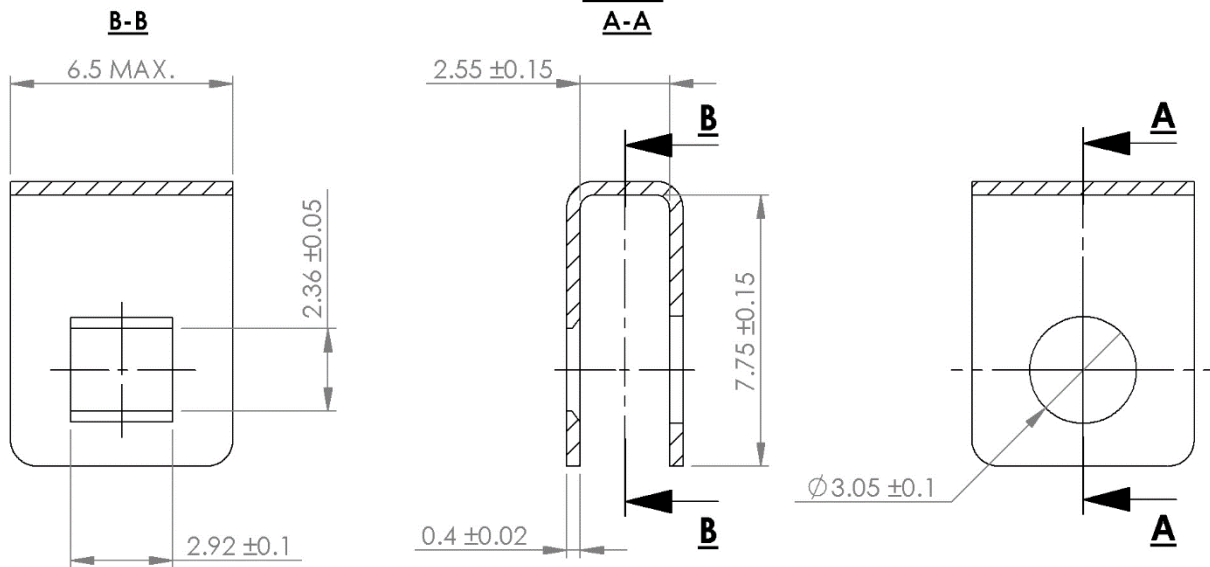

NOTES:

1. All dimensions in mm
2. Weight:
 - Screw 0.69g
 - Clip 0.35g
- 3.

Torque Values	Min(Nm)	Max (Nm)
Screw	0.28	0.32

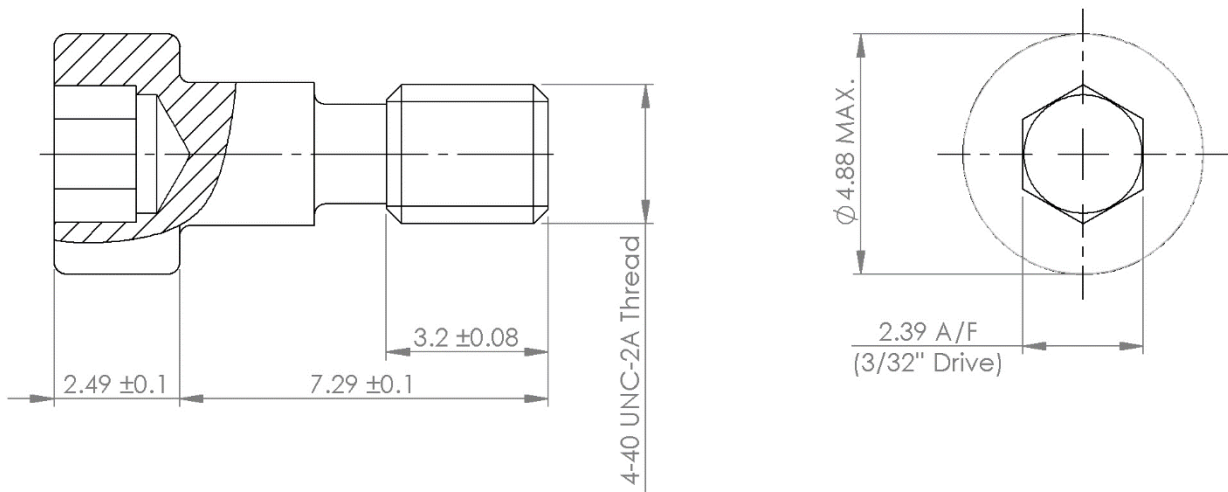
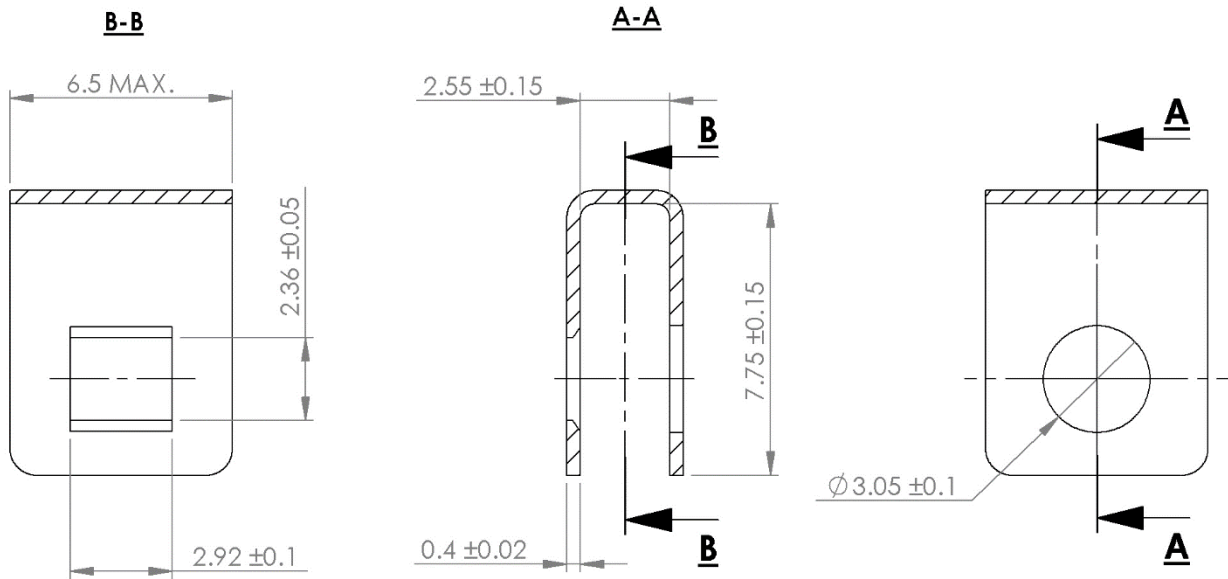
VARIANT 40 - SCREW SUB-ASSEMBLY, HEX. HOLE HEAD (FOR SHELL SIZE 100)
Screw

Clip

NOTES:

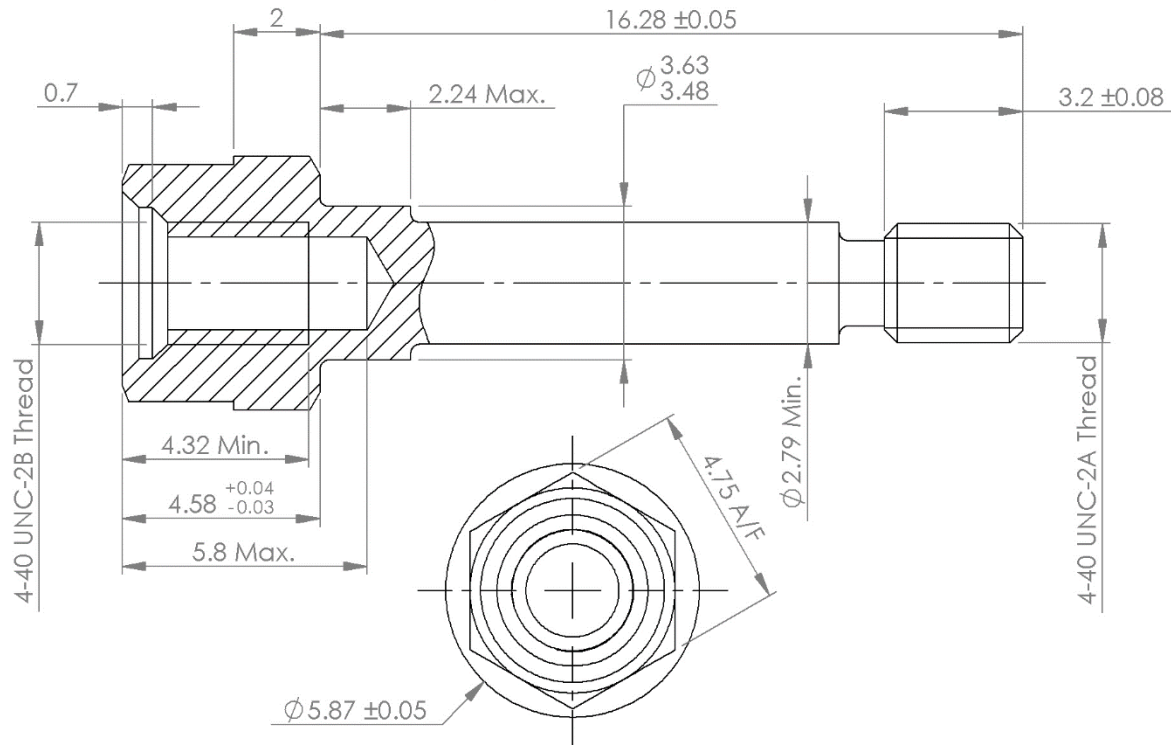
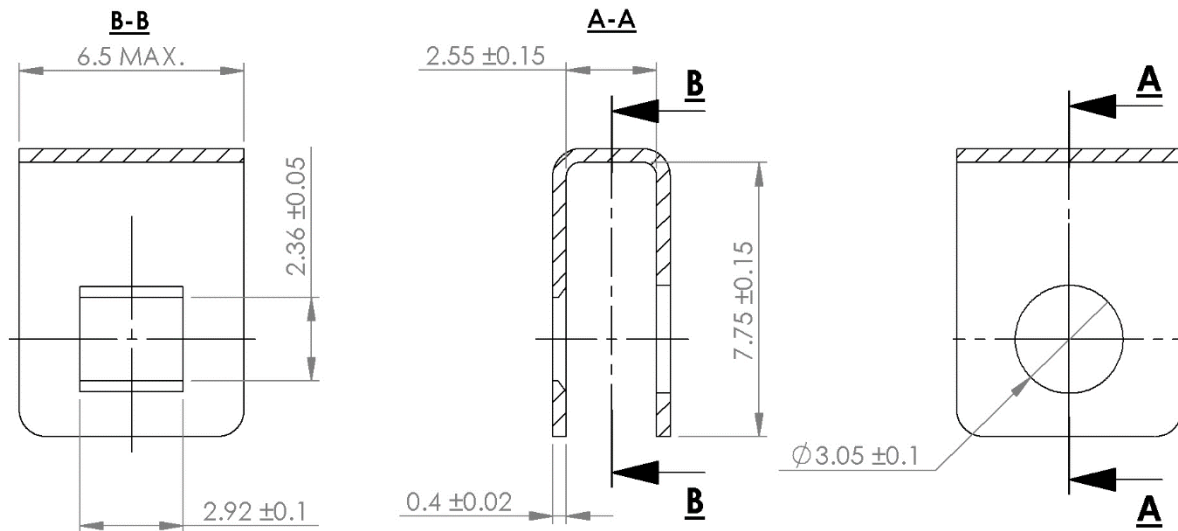
1. All dimensions in mm
2. Weight:
 - Screw 0.63g
 - Clip 0.35g
- 3.

Torque Values	Min(Nm)	Max (Nm)
Screw	0.28	0.32

VARIANT 41 - SCREWLOCK ASSEMBLY FOR CONNECTOR SAVERS (FOR SHELL SIZE 100)
Screwlock

Clip

NOTES:

- All dimensions in mm
- Weight:
 - Screwlock 1.58g
 - Clip 0.35g
-

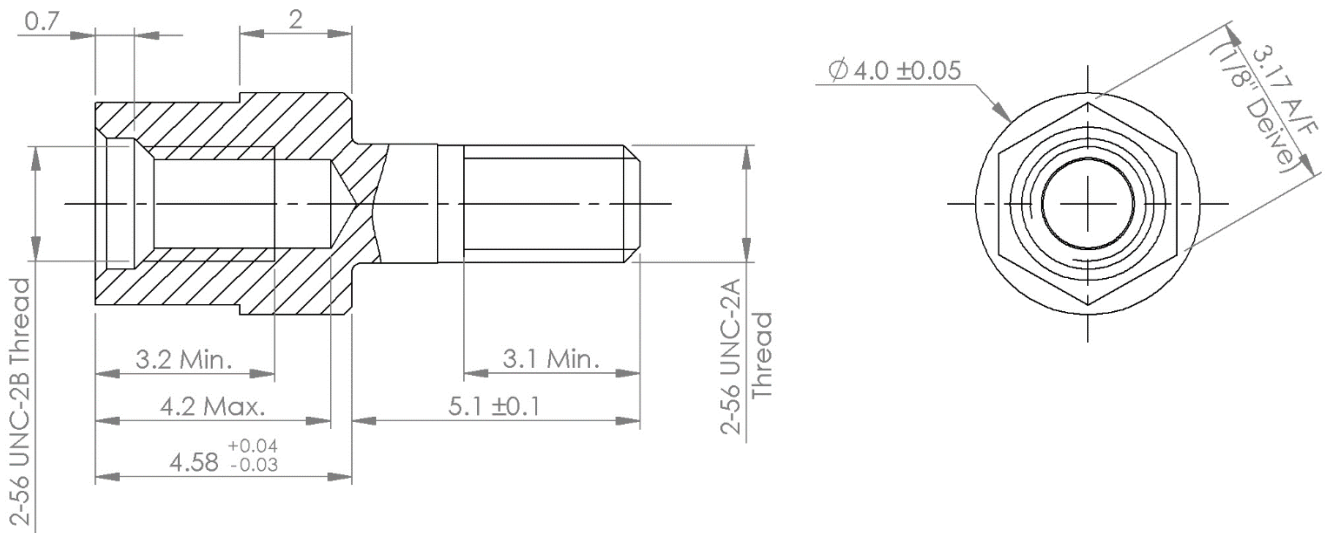
Torque Values	Min(Nm)	Max (Nm)
Screwlock male side	0.28	0.32
Screwlock female side	0.28	0.32

**VARIANT 42 - SCREWLOCK FOR CONNECTORS GMR7580, GMR7590
(FOR SHELL SIZE 9 TO 69)**



NOTES:

1. All dimensions in mm.
2. Weight:
 - Screwlock 0.48g
- 3.

Torque Values	Min (Nm)	Max (Nm)
Screwlock male side	0.44	0.48
Screwlock female side	0.28	0.32

**VARIANT 43 - SCREWLOCK FOR CONNECTORS GMR7580, GMR7590
(FOR SHELL SIZE 100)**

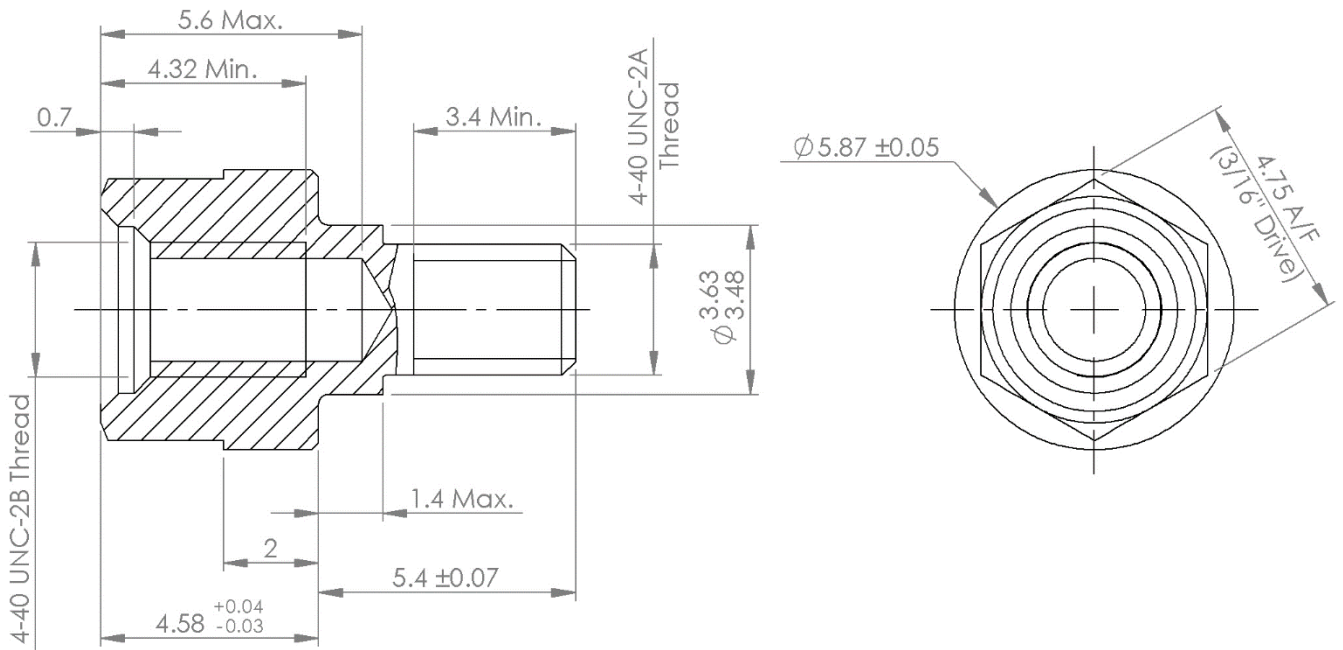

NOTES:

1. All dimensions in mm.
2. Weight:
 - Screwlock 1g
- 3.

Torque Values	Min (Nm)	Max (Nm)
Screwlock male side	0.4	0.45
Screwlock female side	0.28	0.32

**VARIANT 44 – SCREW SUB-ASSEMBLY FOR LIGHTWEIGHT BACKSHELL, HEX. HOLE HEAD
(FOR SHELL SIZE 9 TO 69)**

Screw

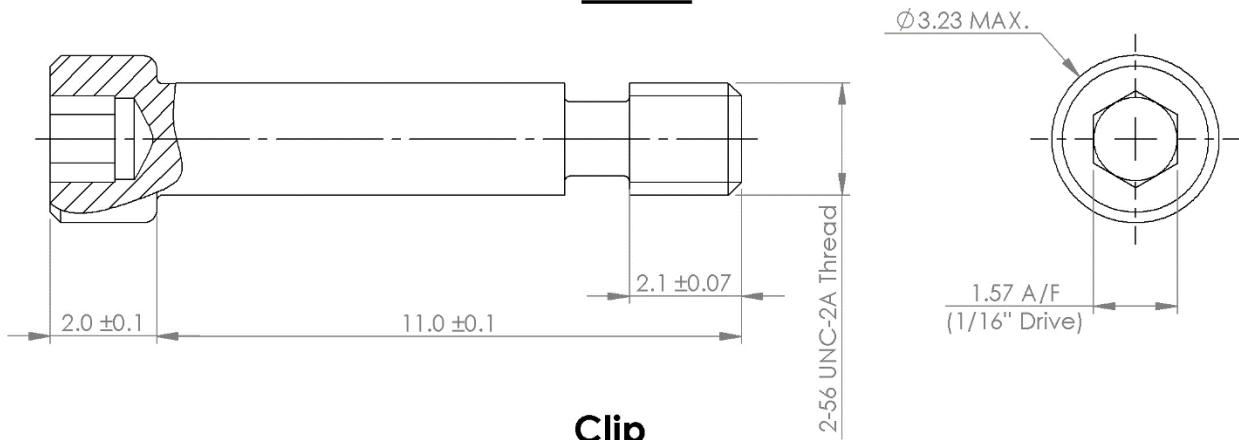

Clip

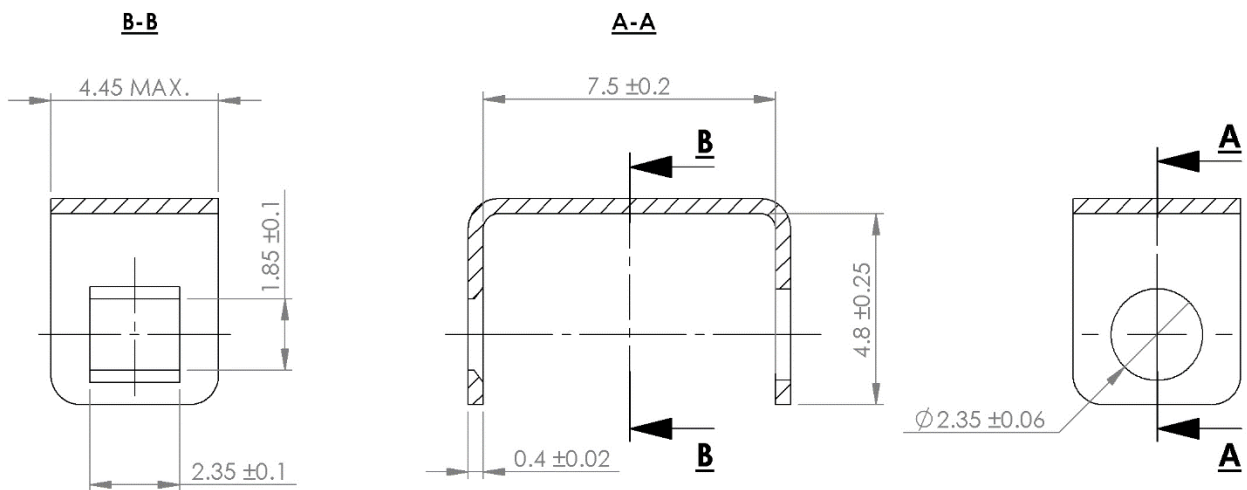

NOTES:

1. All dimensions in mm
2. Weight:
 - Screw 0.45g
 - Clip 0.2g
- 3.

Torque Values	Min(Nm)	Max (Nm)
Screw	0.28	0.32

**VARIANT 45 – SCREW SUB-ASSEMBLY FOR LIGHTWEIGHT BACKSHELL, SLOT HEAD
(FOR SHELL SIZE 100)**

Screw

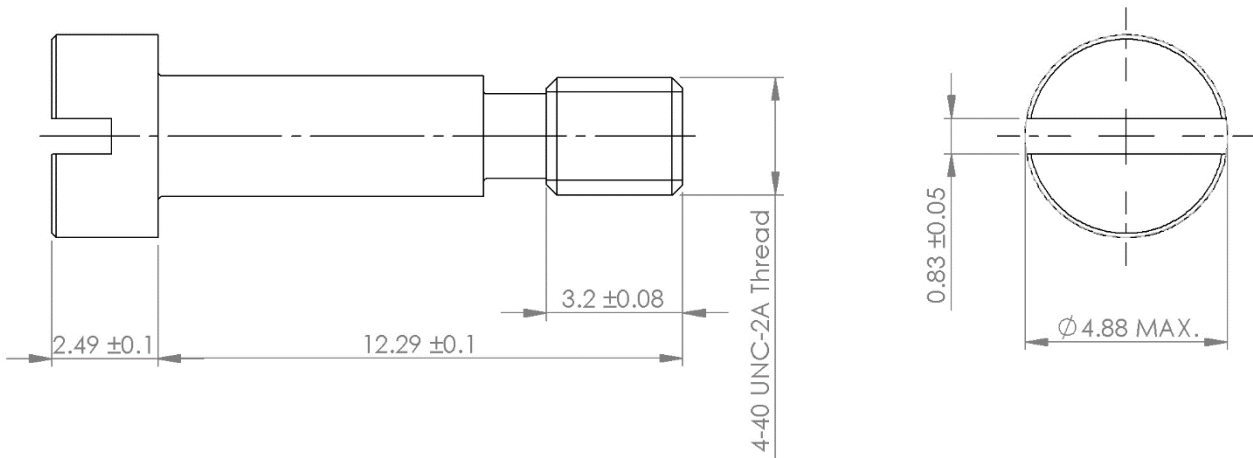

Clip

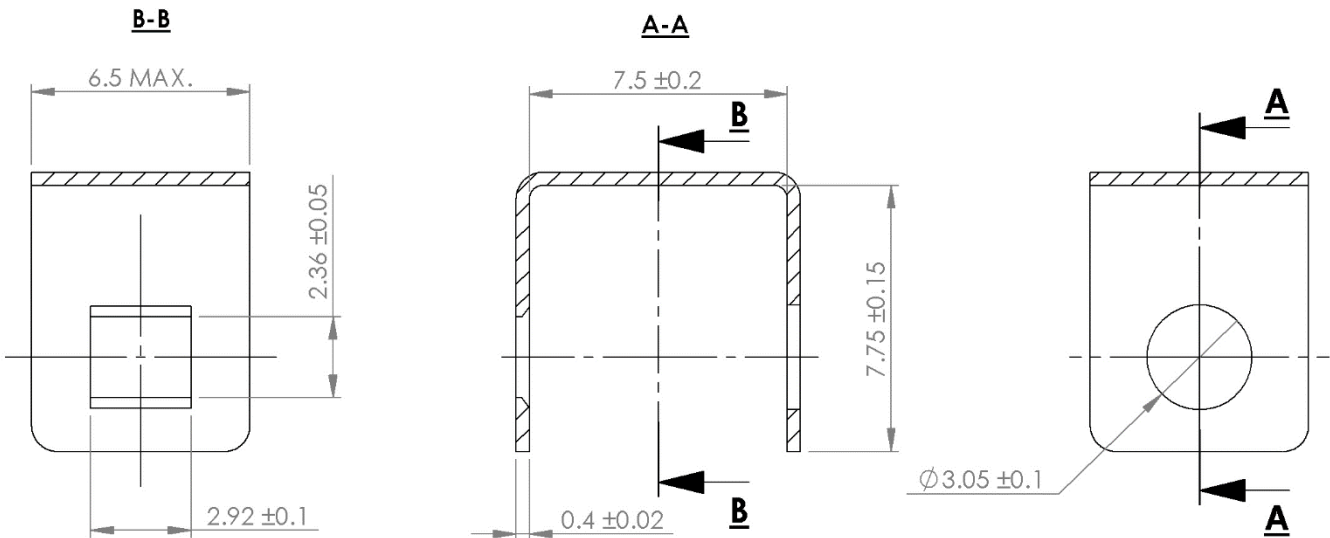

NOTES:

1. All dimensions in mm
2. Weight:
 - Screw 0.95g
 - Clip 0.45g
- 3.

Torque Values	Min(Nm)	Max (Nm)
Screw	0.28	0.32

**VARIANT 46 – SCREW SUB-ASSEMBLY FOR LIGHTWEIGHT BACKSHELL, HEX. HOLE HEAD
(FOR SHELL SIZE 100)**

Screw

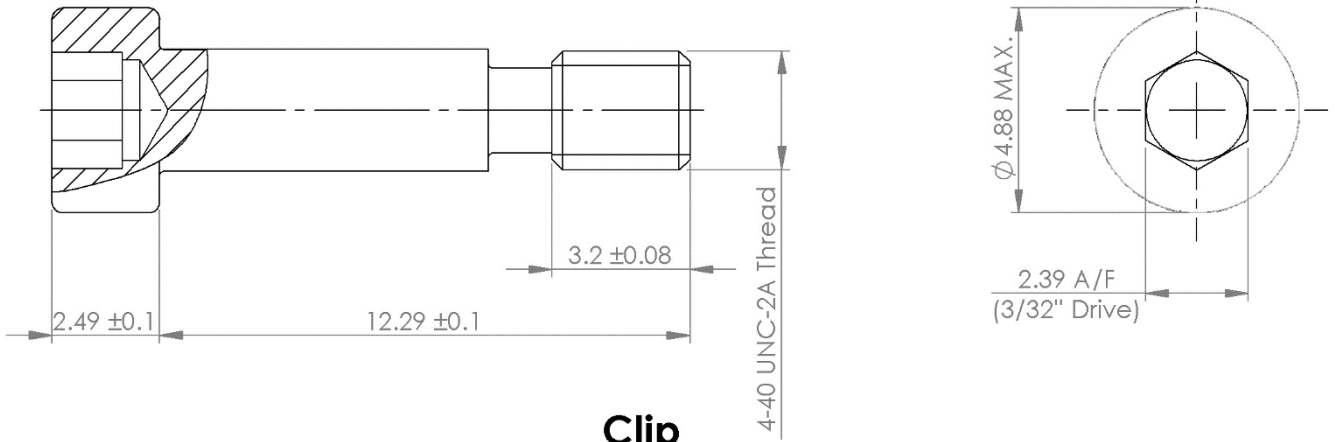

Clip

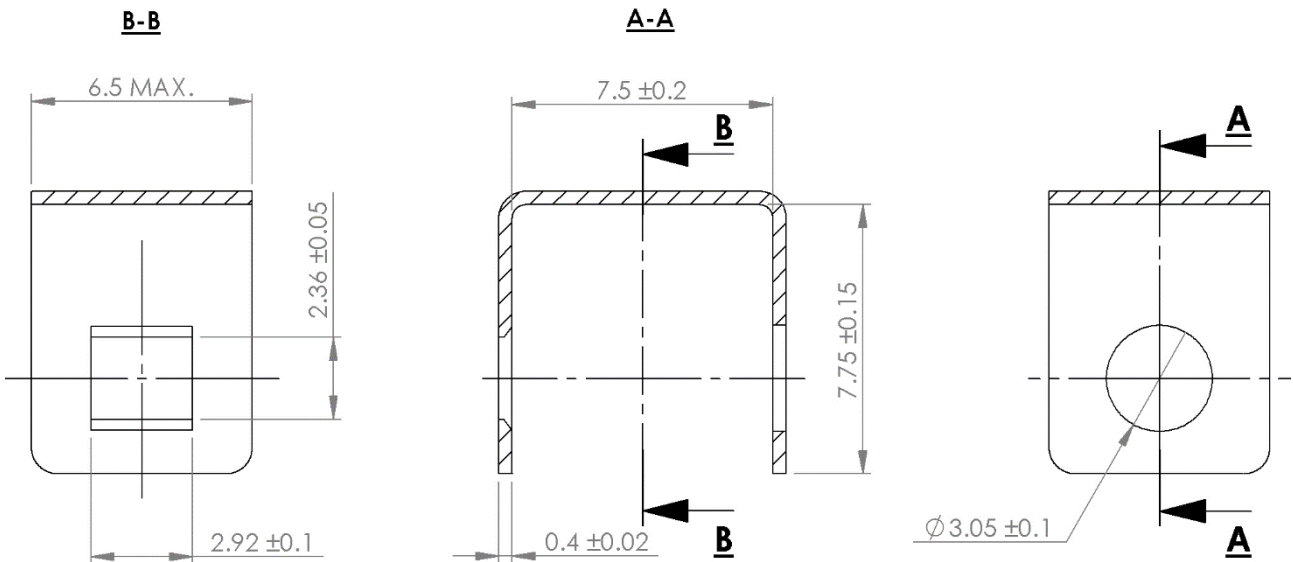

NOTES:

1. All dimensions in mm
2. Weight:
 - Screw 0.90g
 - Clip 0.45g
- 3.

Torque Values	Min(Nm)	Max (Nm)
Screw	0.28	0.32

VARIANT 47 - SCREWLOCK SUB-ASSEMBLY (FRONT PANEL MOUNTING) WITH NUT AND SPLIT RING (FOR SHELL SIZE 9 TO 69)

Screwlock

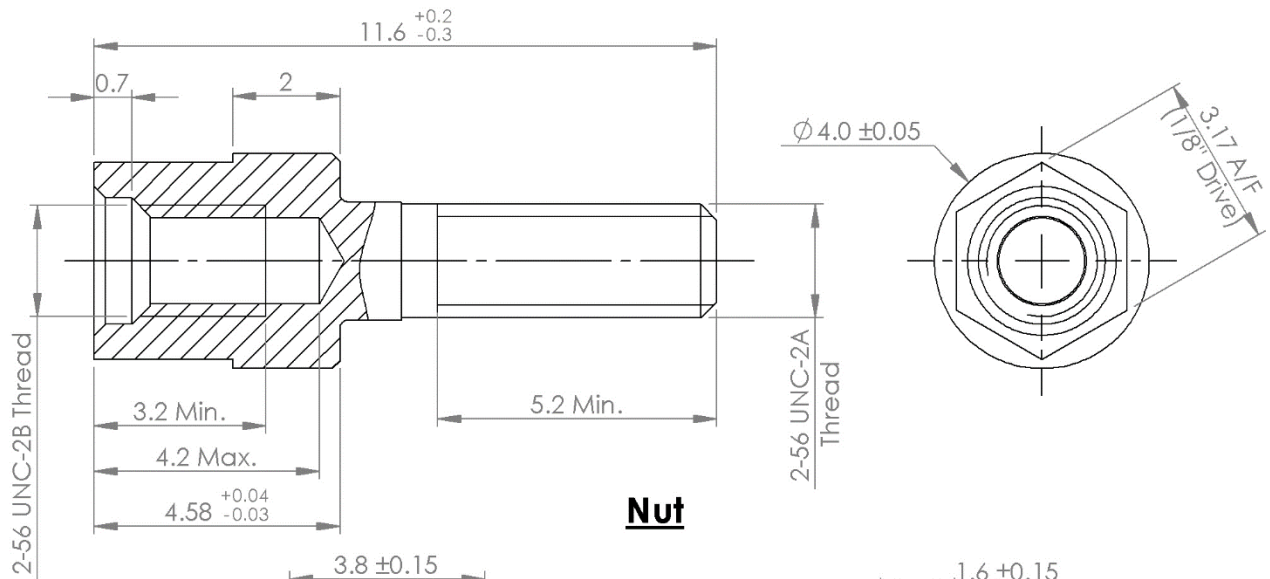

Nut

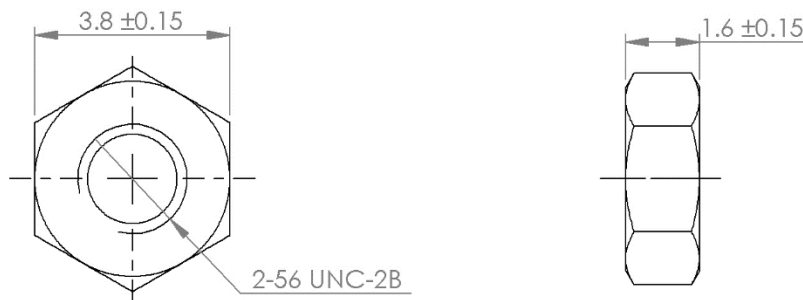

Split Ring

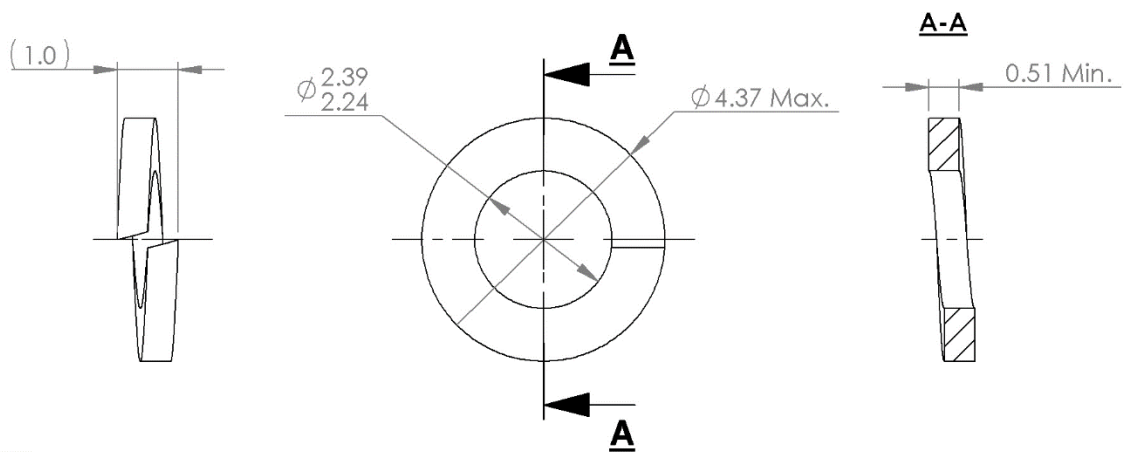

NOTES:

1. All dimensions in mm
2. Weight:
 - Screwlock 0.51g
 - Nut 0.13g
 - Split-Ring 0.05g
- 3.

Torque Values	Min(Nm)	Max (Nm)
Screwlock male side	0.44	0.48
Screwlock female side	0.28	0.32
Nut	0.44	0.48

VARIANT 48 - SCREWLOCK SUB-ASSEMBLY (FRONT PANEL MOUNTING) WITH NUT AND SPLIT RING (FOR SHELL SIZE 100)

Screwlock

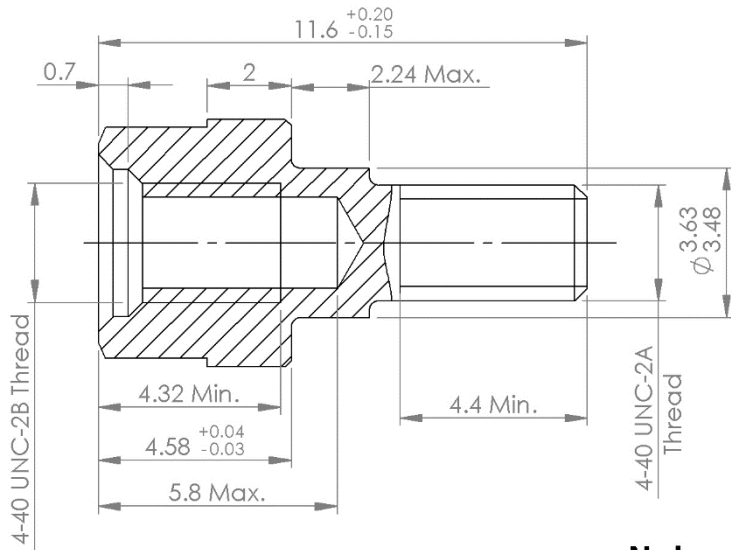

Nut

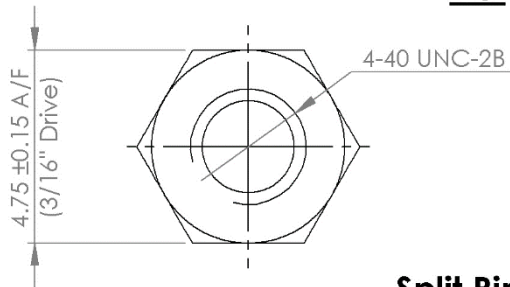

Split Ring

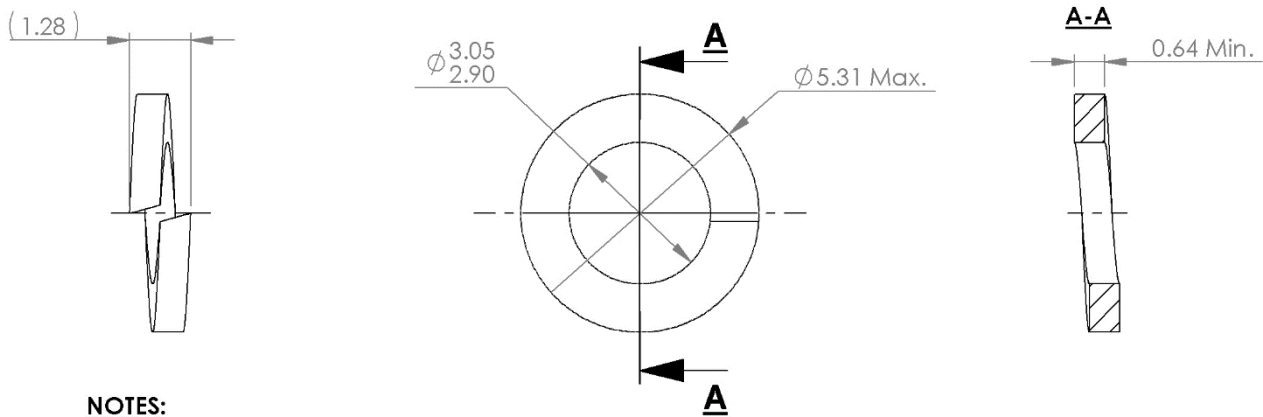

NOTES:

1. All dimensions in mm
2. Weight:
 - Screwlock 1.10g
 - Nut 0.21g
 - Split-Ring 0.08g
- 3.

Torque Values	Min(Nm)	Max (Nm)
Screwlock male side	0.40	0.45
Screwlock female side	0.28	0.32
Nut	0.40	0.45

VARIANTS 49 TO 53 - SCREWLOCK SUB-ASSEMBLY (REAR PANEL MOUNTING) WITH NUT AND SPLIT RING (FOR SHELL SIZE 9 TO 69) PANEL THICKNESS 0.8 TO 2.4mm

Screwlock

Variant	49	50	51	52	53
Panel Thickness (+0.2 / -0)	0.8	1.2	1.6	2	2.4
Dimension A	0.7	1.1	1.5	1.9	2.3

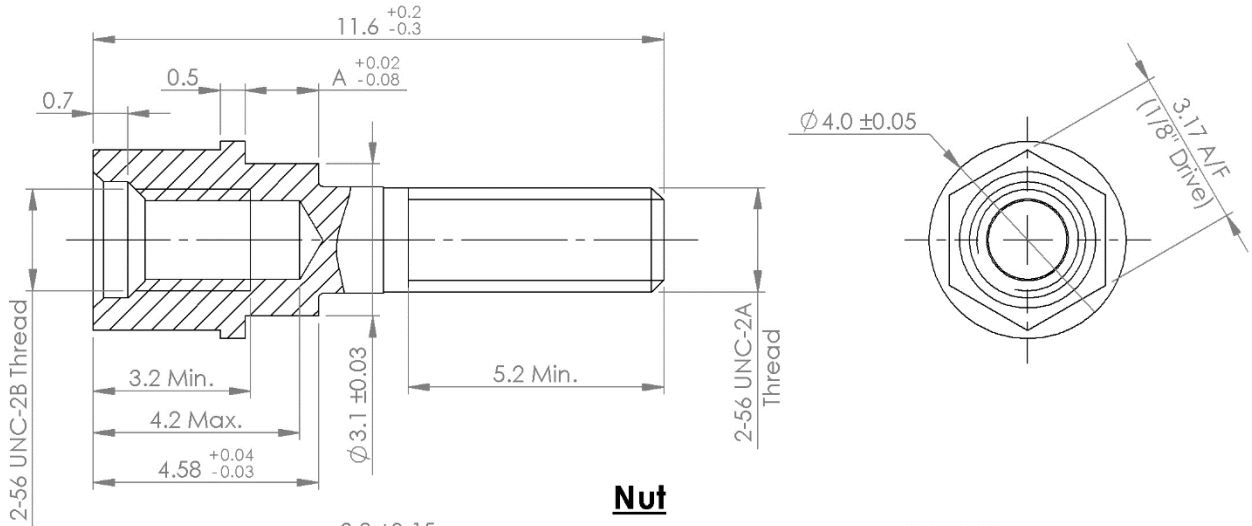

Nut

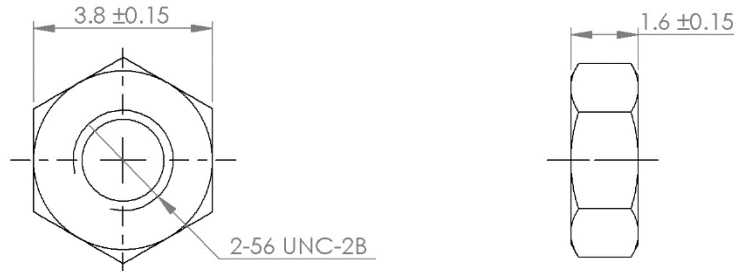

Split Ring

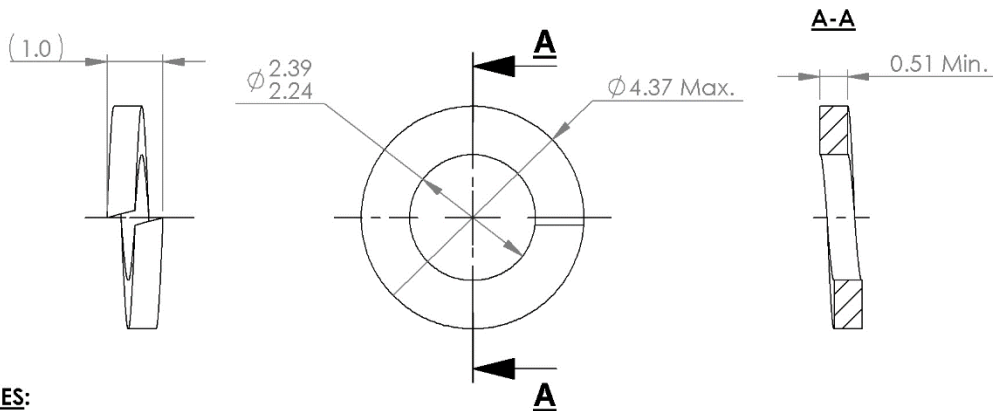

NOTES:

- All dimensions in mm
- Weight:
 - Screwlock 0.45g
 - Nut 0.13g
 - Split-Ring 0.05g
-

Torque Values	Min (Nm)	Max (Nm)
Screwlock male side	0.44	0.48
Screwlock female side	0.28	0.32
Nut	0.44	0.48

VARIANTS 54 TO 58 - SCREWLOCK SUB-ASSEMBLY (REAR PANEL MOUNTING) WITH NUT AND SPLIT RING (FOR SHELL SIZE 100) PANEL THICKNESS 0.8 TO 2.4mm

Screwlock

Variant	54	55	56	57	58
Panel Thickness (+0.2 / -0)	0.8	1.2	1.6	2	2.4
Dimension A	0.7	1.1	1.5	1.9	2.3

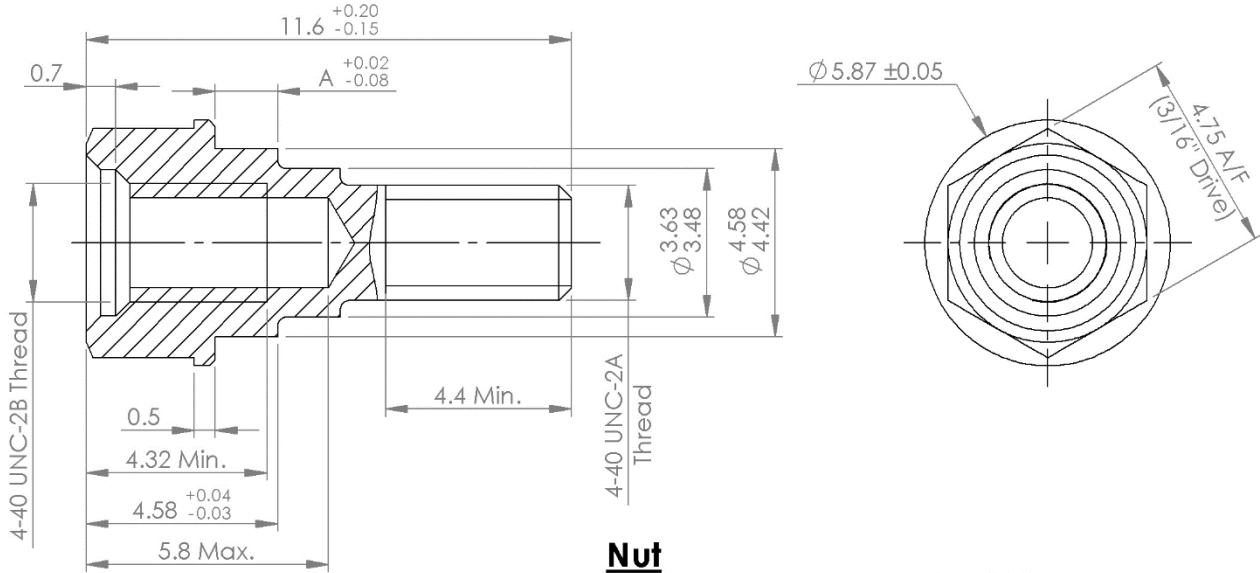

Nut

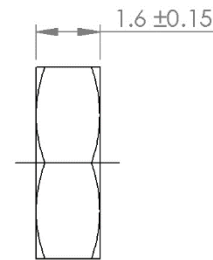
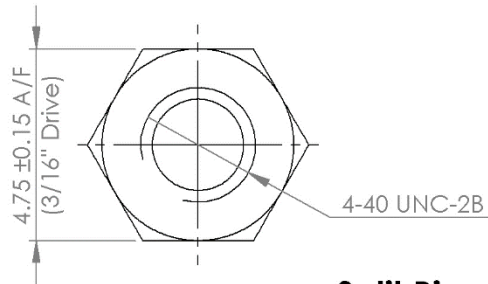

Split Ring

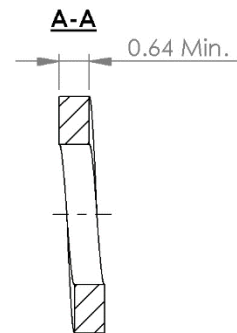
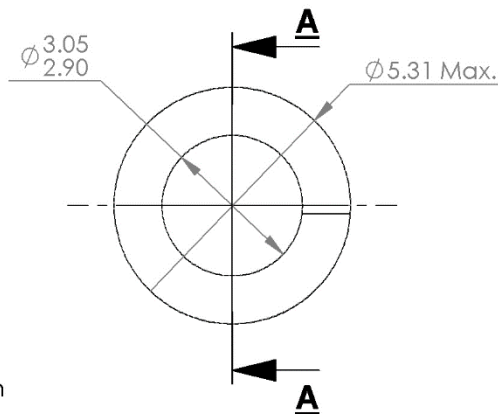
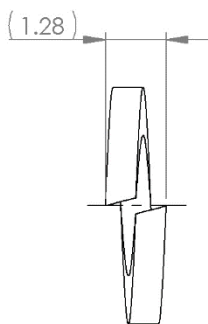

NOTES:

- All dimensions in mm
- Weight:
 - Screwlock 0.95g
 - Nut 0.21g
 - Split-Ring 0.08g
-

Torque Values	Min(Nm)	Max (Nm)
Screwlock male side	0.40	0.45
Screwlock female side	0.28	0.32
Nut	0.40	0.45

VARIANTS 59 TO 63 - SCREWLOCK FOR CONNECTORS GMR7580, GMR7590 (REAR PANEL MOUNTING) (SHELL SIZE 9 TO 69), PANEL THICKNESS 0.8 TO 2.4MM

Variants (To be confirm)	59	60	61	62	63
Panel Thickness (+0.2 / -0)	0.8	1.2	1.6	2	2.4
Dimension A	0.7	1.1	1.5	1.9	2.3

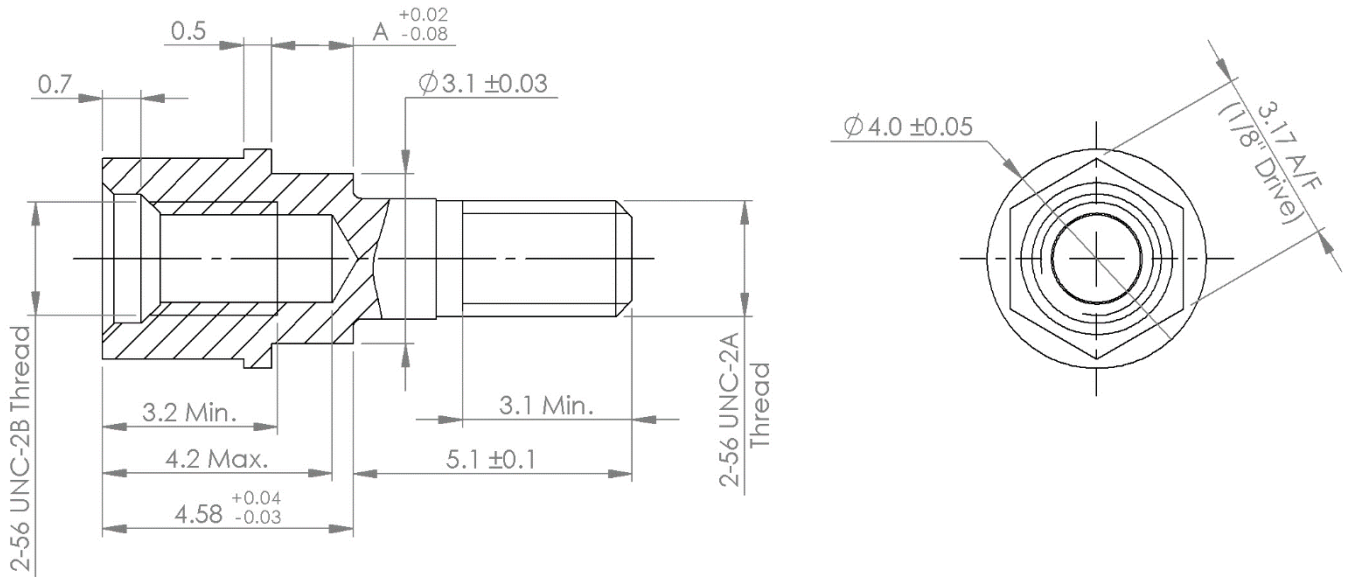

NOTES:

- All dimensions in mm
- Weight:
 - Screwlock 0.41g

3.	Torque Values	Min(Nm)	Max (Nm)
	Screwlock male side	0.44	0.48
	Screwlock female side	0.28	0.32

VARIANTS 64 TO 68 - SCREWLOCK FOR CONNECTORS GMR7580, GMR7590 (REAR PANEL MOUNTING) (SHELL SIZE 100), PANEL THICKNESS 0.8 TO 2.4MM

Variants (No's to be confirm)	64	65	66	67	68
Panel Thickness (+0.2 / -0)	0.8	1.2	1.6	2	2.4
Dimension A	0.7	1.1	1.5	1.9	2.3

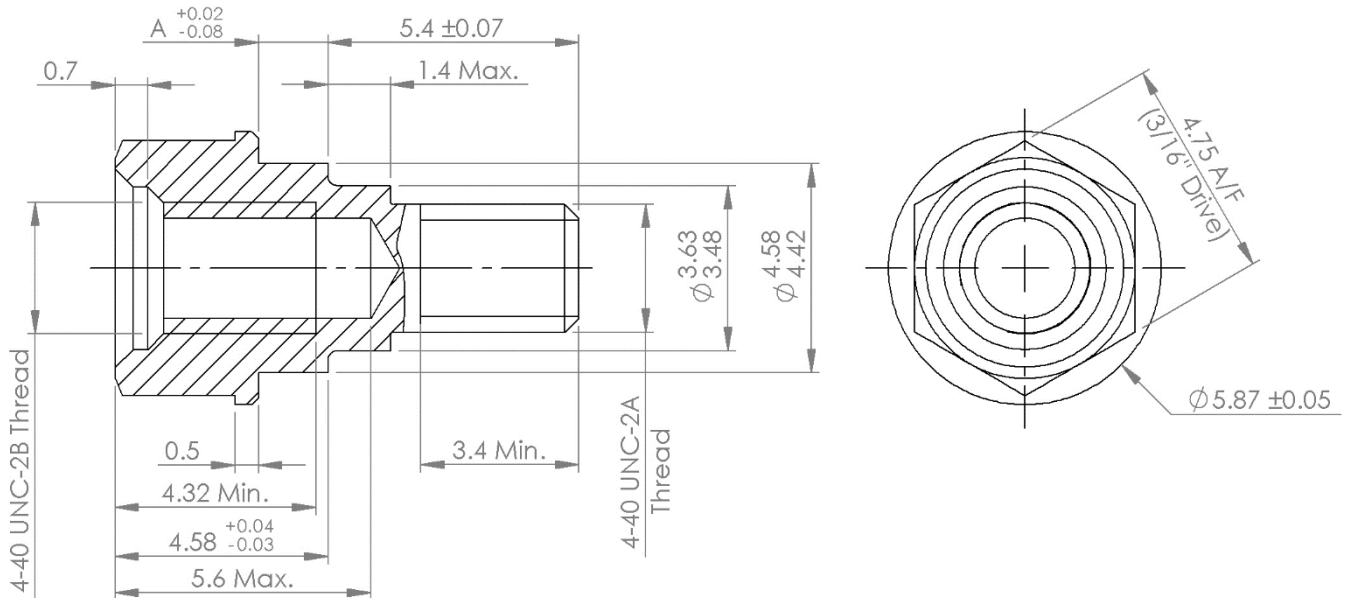

NOTES:

- All dimensions in mm
- Weight:
 - Screwlock 0.85g

3.

Torque Values	Min(Nm)	Max (Nm)
Screwlock male side	0.40	0.45
Screwlock female side	0.28	0.32

2 APPLICABLE DOCUMENTS

The following documents form part of this specification and shall be read in conjunction with it:

- ESCC Generic Specification No. [3401](#), Connectors, Electrical, Circular and Rectangular.
- ESCC Detail Specification No. [3401/029](#), Connectors, Electrical, Rectangular, Microminiature, based on Type MDM.
- ESCC Detail Specification No. [3401/041](#), Connector Savers, Electrical, Rectangular, Microminiature, based on type MDM.
- ESCC Detail Specification No. [3401/077](#), Connectors, Electrical, Rectangular, Microminiature, Removable Contacts, based on Type MDMA.
- ESCC Detail Specification No. [3401/087](#), Lightweight Accessories for Rectangular, Microminiature Connectors, [3401/029](#) and [3401/077](#).

3 TERMS, DEFINITIONS, ABBREVIATIONS, SYMBOLS AND UNITS

For the purpose of this specification, the terms, definitions, abbreviations, symbols and units specified in ESCC Basic Specification No. 21300 shall apply.

4 REQUIREMENTS

4.1 GENERAL

The complete requirements for procurement of the accessories specified herein are stated in this specification and ESCC Generic Specification No. 3401. Deviations from the Generic Specification, applicable to this specification only, are listed in Para. 4.2.

Deviations from the applicable Generic Specification and this Detail Specification, formally agreed with specific Manufacturers on the basis that the alternative requirements are equivalent to the ESCC requirements and do not affect the components' reliability, are listed in the appendices attached to this specification.

4.2 DEVIATIONS FROM GENERIC SPECIFICATION

4.2.1 Deviations from Special In-process Controls

Only Para. 5.2.1 shall apply.

4.2.2 Deviations from Final Production Tests (Chart II)

Only the following tests shall be performed:

- (a) Para. 9.6, Dimension Check.
- (b) Para. 9.7, External Visual Inspection. The magnification shall be x3.

4.2.3 Deviations from Burn-in and Electrical Measurements (Chart III)

Chart III is not applicable.

4.2.4 Deviations from Qualification, Environmental and Endurance Tests (Chart IV)

Chart IV is not applicable.

4.2.5 Deviations from Lot Acceptance Tests (Chart V)

Chart V is not applicable.

4.3 MECHANICAL REQUIREMENTS

4.3.1 Dimension Check

The dimensions of the accessories specified herein shall be verified in accordance with the requirements set out in Para. 9.6 of ESCC Generic Specification No. 3401 and Para. 4.2.2 of this specification; they shall conform to those shown in Figure 2.

4.3.2 Weight

The maximum weight of the accessories specified herein shall be as specified in Figure 2.

4.3.3 Torque Value

The torque value to be used for tightening the screws of the accessories specified herein shall be as specified in Table 1(b).

4.4 MATERIALS AND FINISHES

The materials and finishes shall be as specified herein. Where a definite material is not specified, a material which will enable the components specified herein to meet the performance requirements of this specification shall be used. Acceptance or approval of any constituent material does not guarantee acceptance of the finished product.

4.4.1 Screw Lock Assemblies and Brackets

These shall be made of passivated stainless steel, type 303.

4.4.2 Interfacial Seals

These shall be made of silicon base rubber.

4.5 MARKING

4.5.1 General

The marking of components delivered to this specification shall be in accordance with the requirements of ESCC Basic Specification No. [21700](#) and the following paragraphs. Each component shall be marked in respect of:

- (a) The ESCC qualified components symbol (for ESCC qualified components only).
- (b) The ESCC Component Number.
- (c) Traceability Information.

These components being too small to accommodate the marking specified above, the ESCC marking information shall accompany the component in its primary package.

4.5.2 The ESCC Component Number

The ESCC Component Number shall be constituted and marked as follows:

Example: 340103203B

- Detail Specification Number: 3401032
- Type Variant (See Figure 2): 03
- Testing Level: B

4.5.3 Traceability Information

Traceability information shall be marked in accordance with ESCC Basic Specification No. [21700](#).

4.6 ELECTRICAL MEASUREMENTS

Not applicable.

4.7 SCREENING TESTS (TABLES 4 AND 5)

Not applicable.

4.8 ENVIRONMENTAL AND ENDURANCE TESTS

Not applicable.