



## **RF CABLE ASSEMBLIES**

### **ESCC Generic Specification No. 3408**

Issue 4	October 2023
---------	--------------



### **LEGAL DISCLAIMER AND COPYRIGHT**

European Space Agency, Copyright © 2023. All rights reserved.

The European Space Agency disclaims any liability or responsibility, to any person or entity, with respect to any loss or damage caused, or alleged to be caused, directly or indirectly by the use and application of this ESCC publication.

This publication, without the prior permission of the European Space Agency and provided that it is not used for a commercial purpose, may be:

- copied in whole, in any medium, without alteration or modification.
- copied in part, in any medium, provided that the ESCC document identification, comprising the ESCC symbol, document number and document issue, is removed.

**DOCUMENTATION CHANGE NOTICE**

(Refer to <https://escies.org> for ESCC DCR content)

DCR No.	CHANGE DESCRIPTION
1505	Specification upissued to incorporate changes per DCR.

**TABLE OF CONTENTS**

1	INTRODUCTION	8
1.1	SCOPE	8
1.2	APPLICABILITY	8
2	APPLICABLE DOCUMENTS	8
2.1	ESCC SPECIFICATIONS	8
2.2	OTHER (REFERENCE) DOCUMENTS	9
2.3	ORDER OF PRECEDENCE	9
3	TERMS, DEFINITIONS, ABBREVIATIONS, SYMBOLS AND UNITS	9
4	REQUIREMENTS	10
4.1	GENERAL	10
4.1.1	Specifications	10
4.1.2	Conditions and Methods of Test	10
4.1.3	Manufacturer's Responsibility for Performance of Tests and Inspections	10
4.1.4	Inspection Rights	10
4.1.5	Customer Source Inspections	10
4.2	QUALIFICATION AND QUALIFICATION MAINTENANCE REQUIREMENTS ON A MANUFACTURER	11
4.3	DELIVERABLE COMPONENTS	11
4.3.1	ESCC Qualified Components	11
4.3.2	ESCC Components	11
4.3.3	Component Failure	11
4.4	MARKING	12
4.5	MATERIALS AND FINISHES	12
4.6	ADD-ON COMPONENTS: SELECTION AND PROCUREMENT	12
4.6.1	General	12
4.6.2	Supplier Selection	13
4.6.3	Traceability	13
4.6.4	Changes in Add-on Components	13
4.6.5	Documentation of Add-on Components	13
5	PRODUCTION CONTROL (SPECIAL IN-PROCESS CONTROLS)	14
5.1	GENERAL	14
5.1.1	Rework	14
5.2	DOCUMENTATION	14
6	SCREENING TESTS	15
6.1	GENERAL	15
6.2	FAILURE CRITERIA	15
6.2.1	Environmental and Mechanical Test Failure	15

6.2.2	Parameter Limit Failure	15
6.2.3	Other Failures	15
6.3	FAILED COMPONENTS	15
6.4	DOCUMENTATION	15
7	QUALIFICATION, QUALIFICATION MAINTENANCE AND LOT VALIDATION TESTING	16
7.1	QUALIFICATION TESTING	16
7.1.1	General	16
7.1.2	Distribution within the Qualification Test Lot	16
7.2	QUALIFICATION MAINTENANCE (PERIODIC TESTING)	17
7.3	LOT VALIDATION TESTING	17
7.4	FAILURE CRITERIA	17
7.4.1	Environmental and Mechanical Test Failure	17
7.4.2	Electrical Failure	18
7.4.3	Other Failures	18
7.5	FAILED COMPONENTS	18
7.6	QUALIFICATION, PERIODIC TESTING AND LOT VALIDATION TESTING SAMPLES	18
7.7	DOCUMENTATION	18
8	TEST METHODS AND PROCEDURES	19
8.1	TEST VEHICLES FOR QUALIFICATION, PERIODIC TESTING AND LOT VALIDATION TESTING	19
8.2	CONTACT CAPABILITY	20
8.3	GOLD PLATE POROSITY	20
8.4	PLATING THICKNESS	20
8.5	MAGNETISM LEVEL	20
8.6	PRE-ASSEMBLY VISUAL INSPECTION AND DIMENSION CHECK	20
8.7	INSULATION FLAWS (SPARK TEST)	21
8.8	MICROSECTIONING OF STRANDS	21
8.9	ANTHONY AND BROWN TEST	21
8.10	COATING TESTS	21
8.11	ADHESION OF INNER CONDUCTOR	21
8.12	DIELECTRIC STRENGTH OF JACKET	22
8.13	CONDUCTOR RESISTANCE	22
8.14	CAPACITANCE	22
8.15	CHARACTERISTIC IMPEDANCE	22
8.16	LENGTH AND WEIGHT (OF RF CABLE ASSEMBLY)	22
8.17	TEMPERATURE CYCLING	22
8.17.1	During Screening Tests (Chart F3)	22
8.17.2	During Qualification Testing, Periodic Testing and Lot Validation Testing (Chart F4A)	23

8.17.3	During Periodic Testing and Lot Validation Testing (Chart F4B)	23
8.18	COUPLING PROOF TORQUE	24
8.19	MATING AND UNMATING FORCES	24
8.19.1	During Screening Tests (Chart F3)	24
8.19.2	During Qualification, Periodic Testing and Lot Validation Testing (Charts F4A and F4B)	25
8.20	ELECTRICAL MEASUREMENTS	25
8.20.1	General	25
8.20.2	Room Temperature Electrical Measurements	26
8.20.3	Intermediate and End-Point Electrical Measurements	26
8.20.4	Electrical Measurements at Room, High and Low Temperatures	27
8.21	MULTIPLICATION	27
8.22	RADIOGRAPHIC INSPECTION	27
8.23	RF INTERFACE GAUGING	28
8.24	EXTERNAL VISUAL INSPECTION	28
8.25	SHIELDING EFFECTIVENESS	28
8.26	CABLE RETENTION FORCE	28
8.27	RADIATION	29
8.28	AGEING	30
8.29	MATING ENDURANCE	30
8.30	BENDING	30
8.31	VIBRATION (RANDOM AND SINE)	31
8.31.1	Random Vibration	31
8.31.2	Sine Vibration	31
8.32	CORONA	32
8.33	RF POWER HANDLING	32
8.34	RF POWER CYCLING	33
8.35	THERMAL STABILITY OF INSERTION LOSS	34
8.36	CRIMP CONTACT TENSILE STRENGTH	35
8.37	PERMANENCE OF MARKING	35
8.38	DESTRUCTIVE PHYSICAL ANALYSIS (DPA)	35
9	DATA DOCUMENTATION	36
9.1	GENERAL	36
9.1.1	Qualification and Qualification Maintenance	36
9.1.2	Component Procurement and Delivery	36
9.1.3	Additional Documentation	36
9.1.4	Data Retention/Data Access	36
9.2	COVER SHEET(S)	37

9.3	LIST OF EQUIPMENT USED	37
9.4	LIST OF TEST REFERENCES	37
9.5	ADD-ON COMPONENTS DOCUMENTATION	37
9.6	SPECIAL IN-PROCESS CONTROLS DATA (CHART F2)	37
9.7	SCREENING TESTS DATA (CHART F3)	38
9.8	QUALIFICATION, PERIODIC TESTING AND LOT VALIDATION TESTING DATA (CHARTS F4A AND F4B)	38
9.8.1	Qualification Testing (Chart F4A)	38
9.8.2	Periodic Testing for Qualification Maintenance (Chart F4A or F4B)	38
9.8.3	Lot Validation Testing (Charts F4A and/or F4B)	38
9.9	FAILED COMPONENTS LIST AND FAILURE ANALYSIS REPORT	38
9.10	CERTIFICATE OF CONFORMITY	39
10	DELIVERY	39
11	PACKAGING AND DISPATCH	39
12	CHARTS	40
12.1	CHART F1 - GENERAL FLOW FOR PROCUREMENT	40
12.2	CHART F2 - PRODUCTION CONTROL (SPECIAL IN-PROCESS CONTROLS)	41
12.3	CHART F3 - SCREENING TESTS	42
12.4	CHART F4 – QUALIFICATION, PERIODIC TESTING AND LOT VALIDATION TESTING	43
12.4.1	Chart F4A - Qualification Testing, Periodic Testing and Lot Validation Testing (Note 1)	43
12.4.2	Chart F4B - Periodic Testing and Lot Validation Testing (Note 1)	45

## 1 INTRODUCTION

### 1.1 SCOPE

This specification defines the general requirements for the qualification, qualification maintenance, procurement, and delivery of RF Cable Assemblies for space applications. This specification contains the appropriate inspection and test schedules and also specifies the data documentation requirements.

An RF cable assembly is defined as being composed of one RF cable with two RF connectors, one on each end, designed and manufactured to achieve an RF electrical function.

Components which are not compliant with the above definition are out of the scope of this specification.

### 1.2 APPLICABILITY

This specification is primarily applicable to the granting of qualification approval to components qualified in accordance with qualification of standard components per ESCC Basic Specification No. [20100](#).

It is also primarily applicable to the procurement of components so qualified.

This specification may also be applied to the procurement of unqualified components, recommendations for which are given in ESCC Basic Specification No. [23100](#).

## 2 APPLICABLE DOCUMENTS

The following documents form part of, and shall be read in conjunction with, this specification. The relevant issues shall be those in effect on the date of starting qualification or placing the Purchase Order.

### 2.1 ESCC SPECIFICATIONS

- No. [20100](#), Requirements for the Qualification of Standard Electronic Components for Space Application.
- No. [20500](#), External Visual Inspection.
- No. [20600](#), Preservation, Packaging and Dispatch of ESCC Components.
- No. [20900](#), Radiographic Inspection of Electronic Components.
- No. [21001](#), Destructive Physical Analysis of EEE Components.
- No. [21300](#), Terms, Definitions, Abbreviations, Symbols and Units.
- No. [21700](#), General Requirements for the Marking of ESCC Components.
- No. [22600](#), Requirements for the Evaluation of Standard Electronic Components for Space Application.
- No. [22800](#), ESCC Non-Conformance Control System.
- No. [23100](#), Recommendations on the use of the ESCC Specification System for the Evaluation and Procurement of Unqualified Components.
- No. [24600](#), Minimum Quality System Requirements.
- No. [24800](#), Resistance to Solvents of Marking, Materials and Finishes.
- No. [3402](#), Connectors, RF Coaxial.
- No. [3902](#), Cables, Coaxial, Radio Frequency, Flexible.



For qualification and qualification maintenance or procurement of qualified components, with the exception of ESCC Basic Specifications Nos. [20100](#), [21700](#), [22800](#) and [24600](#), where Manufacturers' specifications are equivalent to, or more stringent than, the ESCC Basic Specifications listed above, they may be used in place of the latter, subject to the approval of the ESCC Executive.

Such replacements shall be clearly identified in the applicable Process Identification Document (PID).

For procurement of unqualified components, where Manufacturers' specifications are equivalent to or more stringent than the ESCC Basic Specifications listed above, they may be used in place of the latter subject to the approval of the Orderer.

Such replacements may be listed in an appendix to the appropriate Detail Specification at the request of the Manufacturer or Orderer, subject to the approval of the ESCC Executive.

Unless otherwise stated herein, references within the text of this specification to "the Detail Specification" shall mean the relevant ESCC RF cable assembly Detail Specification.

## 2.2 OTHER (REFERENCE) DOCUMENTS

- ECSS-Q-ST-70-08, Manual Soldering of High-Reliability Electrical Connections.
- ECSS-Q-ST-70-26, Crimping of High-Reliability Electrical Connections.
- ECSS-Q-ST-70-37, Determination of the Susceptibility of Metals to Stress-Corrosion Cracking.
- ECSS-E-20-01, Multipaction Design and Test.
- [MIL-STD-202](#), Test Methods for Electronic and Electrical Component Parts.
- IEC Publication No. 61726, Cable Assemblies, Cables, Connectors and Passive Microwave Components - Screening Attenuation Measurement by the Reverberation Chamber Method.

## 2.3 ORDER OF PRECEDENCE

For the purpose of interpretation and in case of conflict with regard to documentation, the following order of precedence shall apply:

- (a) ESCC Detail Specification
- (b) ESCC Generic Specification
- (c) ESCC Basic Specification
- (d) Other documents, if referenced herein

## 3 TERMS, DEFINITIONS, ABBREVIATIONS, SYMBOLS AND UNITS

The terms, definitions, abbreviations, symbols and units specified in ESCC Basic Specification No. [21300](#) shall apply. In addition, the following definitions shall apply:

- Cable Assembly Lot: A single RF cable assembly production lot constituted of RF cable assemblies with the same ESCC Component Number, produced with homogeneous lots of connectors and cables, manufactured and tested in the same time period.
- Add-on Components: RF coaxial connectors and RF coaxial cable used in the manufacture of RF cable assemblies.

## 4 REQUIREMENTS

### 4.1 GENERAL

The test requirements for the qualification of a component shall be in accordance with ESCC Basic Specification No. 20100.

Unless otherwise specified in the Detail Specification, the components subjected to Qualification, Periodic Testing and Lot Validation Testing in accordance with this specification shall be test vehicles in accordance with Para. 8.1.

The test requirements for procurement of both qualified and unqualified Components (see Chart F1) shall comprise:

- Special In-Process Controls
- Screening Tests
- Periodic Testing (for qualified components only)
- Lot Validation Testing if stipulated in the Purchase Order

#### 4.1.1 Specifications

For qualification, qualification maintenance, procurement and delivery of components in conformity with this specification, the applicable specifications listed in Section 2 of this document shall apply in total unless otherwise specified herein or in the Detail Specification.

#### 4.1.2 Conditions and Methods of Test

The conditions and methods of test shall be in accordance with this specification, the ESCC Basic Specifications referenced herein and the Detail Specification.

#### 4.1.3 Manufacturer's Responsibility for Performance of Tests and Inspections

The Manufacturer shall be responsible for the performance of tests and inspections required by the applicable specifications. These tests and inspections shall be performed at the plant of the Manufacturer of the components unless it is agreed by the ESCC Executive (for qualification, qualification maintenance, or procurement of qualified components) or the Orderer (for procurement of unqualified components), to use an approved external facility.

#### 4.1.4 Inspection Rights

The ESCC Executive (for qualification, qualification maintenance, or procurement of qualified components) or the Orderer (for procurement of unqualified components if stipulated in the Purchase Order) reserves the right to monitor any of the tests and inspections scheduled in the applicable specifications.

#### 4.1.5 Customer Source Inspections

##### 4.1.5.1 *Pre-Assembly Source Inspection*

If stipulated in the Purchase Order, the Orderer may perform a source inspection at the Manufacturer's facility prior to assembly of the RF cable assembly (e.g. perform Pre-Assembly Visual Inspection, review of Special In-Process Controls test results, etc.). Details of the inspections to be performed or witnessed and the required period of notification shall be as stipulated in the Purchase Order.

#### 4.1.5.2 *Final Source Inspection*

If stipulated in the Purchase Order, the Orderer may perform a source inspection at the Manufacturer's facility at the end of Screening or during Lot Validation Testing, if applicable (e.g. witness of final Room Temperature Electrical Measurements, performance of External Visual Inspection, review of the data documentation package). Details of the inspections to be performed or witnessed and the required period of notification shall be as stipulated in the Purchase Order.

#### 4.2 QUALIFICATION AND QUALIFICATION MAINTENANCE REQUIREMENTS ON A MANUFACTURER

To obtain and maintain the qualification of a component, or family of components, a Manufacturer shall satisfy the requirements of ESCC Basic Specification No. [20100](#).

#### 4.3 DELIVERABLE COMPONENTS

##### 4.3.1 ESCC Qualified Components

Components delivered to this specification shall be processed and inspected in accordance with the relevant Process Identification Document (PID).

##### 4.3.2 ESCC Components

Each component, irrespective of qualification status, identified with an ESCC component number and delivered to this specification shall:

- be traceable to its cable assembly lot.
- have satisfactorily completed all the tests required by the relevant issues of the applicable specifications.
- be produced from cable assembly lots that are considered by the Manufacturer to be capable of passing all applicable tests, and sequences of tests, that are defined in Charts F4A and F4B. The Manufacturer shall not knowingly supply components that cannot meet this requirement. In the event that, subsequent to delivery and prior to operational use, a component is found to be in a condition such that, demonstrably, it could not have passed these tests at the time of manufacture, this shall be grounds for rejection of the delivered lot.

##### 4.3.3 Component Failure

Component failure of an RF cable assembly may occur during Screening Tests (Chart F3) or Qualification, Periodic Testing and Lot Validation Testing (Charts F4A and F4B). In addition, lot failure of add-on components (connectors or cable) may occur during Special In-Process Controls (Chart F2).

Should such failure occur during qualification, qualification maintenance or procurement of qualified RF cable assemblies, the Manufacturer shall initiate the non-conformance procedure in accordance with ESCC Basic Specification No. [22800](#). The Manufacturer shall notify the Orderer and the ESCC Executive by any appropriate written means, within 5 working days, giving details of the number and mode of failure and the suspected cause. No further testing or analysis shall be performed on the failed components until so instructed by the ESCC Executive.

Should such failure occur during procurement of unqualified components the Manufacturer shall notify the Orderer by any appropriate written means within 5 working days, giving details of the number and mode of failure and the suspected cause. No further testing or analysis shall be performed on the failed components until so instructed by the Orderer. The Orderer shall inform the Manufacturer within 5 working days of receipt of notification what action shall be taken.

#### 4.4 MARKING

All components procured and delivered to this specification shall be marked in accordance with ESCC Basic Specification No. [21700](#).

Marking shall not reduce the cable flexibility or routing and shall not modify the thermal behaviour of the RF cable assembly.

#### 4.5 MATERIALS AND FINISHES

Specific requirements for materials and finishes are specified in the Detail Specification. Where a definite material or finish is not specified a material or finish shall be used so as to ensure that the component meets the performance requirements of this specification and the Detail Specification. Acceptance or approval of any constituent material or finish does not guarantee acceptance of the finished product.

All materials and finishes of the components specified in the Detail Specification shall comply with the restrictions on materials specified in ESCC Basic Specification No. [22600](#).

All metallic materials shall meet stress-corrosion resistance Class 1 or Class 2 of ECSS-Q-ST-70-37.

#### 4.6 ADD-ON COMPONENTS: SELECTION AND PROCUREMENT

##### 4.6.1 General

For ESCC qualified RF cable assemblies, the requirements for selection and procurement of piece parts and materials, including add-on components, used in their manufacture shall be as defined in the Process Identification Document (PID).

The PID shall include a list of add-on components which have been successfully tested according to the requirements of this specification and approved for their inclusion in the PID by the ESCC Executive.

Pure Tin ( $\geq 97\%$ ) shall not be used on internal and external elements of the RF cable assembly; this includes under plating.

##### 4.6.1.1 *Add-on Component: Connectors*

All connectors shall be as specified in the RF cable assembly Detail Specification and shall comply with the requirements specified in ESCC Generic Specification No. [3402](#) or MIL equivalent.

For qualified RF cable assemblies, the detail specification(s) used to procure the connector(s) shall be agreed by the ESCC Executive, shall form part of the PID and may be listed in the RF cable assembly Detail Specification.

When specified in the RF cable assembly Detail Specification, all cavities within a connector and/or a connector body shall be vented. Venting holes design shall not jeopardize the electrical performance of the connector.

#### 4.6.1.2 *Add-on Component: Cables*

All cables shall be as specified in the RF cable assembly Detail Specification and shall comply with the requirements specified in ESCC Generic Specification No. [3902](#).

For qualified RF cable assemblies, the detail specification used to procure the cable shall be agreed by the ESCC Executive, shall form part of the PID and may be listed in the RF cable assembly Detail Specification.

#### 4.6.2 Supplier Selection

The RF cable assembly Manufacturer shall assure that the selected suppliers of add-on components are compliant with the requirements of this ESCC Generic Specification, the RF cable assembly Detail Specification and, for qualified RF cable assemblies, the PID.

#### 4.6.3 Traceability

All add-on components used in the manufacturer of the RF cable assemblies shall each be traceable to their respective production lot and their respective incoming inspection lot.

Records shall be maintained for a minimum of 10 years that provide traceability from each RF cable assembly serial number to each of the add-on components' production lots and incoming inspection lots used in their manufacture.

In case of materials with limited shelf life, appropriate means to verify the validity of the relevant material shall be in place. For qualified manufacturers, the verification and any re-certification shall be in compliance with the Manufacturer's QM plan and the PID.

#### 4.6.4 Changes in Add-on Components

The Manufacturer is responsible for controlling all add-on components. Any change must be controlled and evaluated by the Manufacturer and for qualified RF cable assemblies, finally approved by the ESCC Executive and included in the PID.

The Manufacturer is also responsible for documentation of all changes, for any additional testing due to any changes and, for qualified RF cable assemblies, for notification of the ESCC Executive.

#### 4.6.5 Documentation of Add-on Components

Documentation of the Manufacturer's procurement requirements for add-on components shall be in accordance with Para. 9.5.

## 5 PRODUCTION CONTROL (SPECIAL IN-PROCESS CONTROLS)

### 5.1 GENERAL

Unless otherwise specified, all lots of connectors and cables add-on components used to manufacture the RF cable assemblies used for qualification and qualification maintenance (test vehicles), Lot Validation Testing and for delivery, shall be subject to tests and inspections in accordance with Chart F2 in the sequence shown.

As specified in Chart F2, testing shall be performed on add-on components:

- Connectors (and contacts) (prior to being assembled with cable) from the same lot as used for the RF cable assembly
- Cable (prior to being assembled with connectors) from the same lot as used for the RF cable assembly.

Any connector, connector lots, cable or cable lots (as applicable) which do not meet these requirements shall be rejected and at no future time be resubmitted to the requirements of this specification.

The applicable test requirements are detailed in the paragraphs referenced in Chart F2.

When ESCC qualified connectors or cable are used to manufacture the RF cable assembly type being subjected to Special In-Process Controls, specific tests that have already been performed in accordance with the respective ESCC specifications for the connectors or cable need not be repeated. These tests are indicated in Chart F2.

For qualified RF cable assemblies, the full production control provisions are defined in the PID.

In the event of any connector (or contact) lot or any cable lot being rejected, the Manufacturer shall act in accordance with Para. 4.3.3.

#### 5.1.1 Rework

Any rework procedures shall be agreed by the ESCC Executive (for qualification, qualification maintenance, or procurement of qualified components) or the Orderer (for procurement of unqualified components).

For qualified components, any rework procedures shall be specified in the PID.

Repair is not allowed.

### 5.2 DOCUMENTATION

Documentation of Special In-Process Controls shall be in accordance with Para. 9.6.

## 6 SCREENING TESTS

### 6.1 GENERAL

Unless otherwise specified, all components used for qualification and qualification maintenance (test vehicles), Lot Validation Testing, and for delivery, shall be subjected to tests and inspections in accordance with Chart F3 in the sequence shown.

All components shall be serialised prior to the tests and inspections.

Any components which do not meet these requirements shall be removed from the lot and at no future time be resubmitted to the requirements of this specification.

The applicable test methods and conditions are specified in the paragraphs referenced in Chart F3.

When ESCC qualified connectors are used to manufacture the RF cable assembly type being subjected to Screening Tests, specific tests that have already been performed in accordance with the respective ESCC specifications for the connectors need not be repeated. These tests are indicated in Chart F3.

### 6.2 FAILURE CRITERIA

#### 6.2.1 Environmental and Mechanical Test Failure

The following shall be counted as component failures:

- Components which fail during tests for which the pass/fail criteria are inherent in the test method, e.g. Length and Weight, Coupling Proof Torque, Radiographic Inspection, External Visual Inspection, etc.

#### 6.2.2 Parameter Limit Failure

A component shall be counted as a limit failure if one or more parameters exceed the limits shown in Room Temperature Electrical Measurements in the Detail Specification.

#### 6.2.3 Other Failures

A component shall be counted as a failure in any of the following cases:

- Visual failure.
- Mechanical failure.
- Handling failure.
- Lost component.

### 6.3 FAILED COMPONENTS

A component shall be considered as a failed component if it exhibits one or more of the failure modes described in Para. 6.2.

In the event of any failure during Chart F3, the Manufacturer shall act in accordance with Para. 4.3.3.

### 6.4 DOCUMENTATION

Documentation of Screening Tests shall be in accordance with Para. 9.7.

## 7 QUALIFICATION, QUALIFICATION MAINTENANCE AND LOT VALIDATION TESTING

The requirements of this paragraph are applicable to the tests performed on components or test structures as part of qualification or qualification maintenance in accordance with ESCC Basic Specification No. 20100. They are also applicable to Lot Validation Testing as part of the procurement of qualified or unqualified components.

### 7.1 QUALIFICATION TESTING

#### 7.1.1 General

Qualification Testing shall be in accordance with the requirements specified in Chart F4A. Unless otherwise specified, the tests of Chart F4A shall be performed on the specified sample chosen at random from components (test vehicles) which have successfully passed the tests in Chart F3. This sample constitutes the Qualification Test Lot.

The Qualification Test Lot is divided into subgroups of tests and unless otherwise specified all test vehicles assigned to a subgroup shall be subjected to all of the tests in that subgroup, in the sequence shown. The applicable test requirements are detailed in the paragraphs referenced in Chart F4A.

The conditions governing Qualification Testing are specified in ESCC Basic Specification No. 20100.

When ESCC qualified connectors or cable are used to manufacture the RF cable assembly type being subjected to Qualification Testing, specific tests that have already been performed in accordance with the respective ESCC specifications for the connectors or cable need not be repeated. These tests are indicated in Chart F4A.

#### 7.1.2 Distribution within the Qualification Test Lot

Where a Detail Specification covers a range, or series of components that are considered similar, then the Qualification Test Lot shall be comprised of component types so selected that they adequately represent all of the various mechanical, structural and electrical peculiarities of that range or series.

The distribution shall be as specified by, or agreed with, the ESCC Executive.



## 7.2 QUALIFICATION MAINTENANCE (PERIODIC TESTING)

Qualification is maintained through Periodic Testing and the test requirements of Para. 7.1 and Chart F4B shall apply. Unless otherwise specified, all test vehicles shall be subjected to all of the tests in the sequence shown. The applicable test requirements for Periodic Testing for extension of qualification are detailed in the paragraphs referenced in Chart F4B. The period between successive testing shall be as specified in Chart F4B.

When Periodic Testing is being performed for renewal of qualification after lapse, the test requirements of Chart F4A shall apply.

The conditions governing qualification maintenance are specified in ESCC Basic Specification No. [20100](#).

For qualified components, specific tests in Chart F4B need not be performed for Periodic Testing if there is no change in the material, process and design of the component since initial qualification, subject to technical justification being provided by the Manufacturer and agreed by the ESCC Executive. These tests are indicated in Chart F4B. In this case, Periodic Testing for these specific tests shall be considered as having been performed during the initial qualification. Full details shall be specified in the PID.

When ESCC qualified connectors or cable are used to manufacture the RF cable assembly type being subjected to Periodic Testing, specific tests that have already been performed in accordance with the respective ESCC specifications for the connectors or cable need not be repeated. These tests are indicated in Charts F4A and F4B.

## 7.3 LOT VALIDATION TESTING

For procurement of qualified components, Lot Validation Testing is not required and shall only be performed if specifically stipulated in the Purchase Order.

For procurement of unqualified Components, the need for Lot Validation Testing shall be determined by the Orderer (ref. ESCC Basic Specification No. [23100](#)).

When Lot Validation Testing is required, it shall consist of the performance of one or more of the tests or subgroup test sequences of Chart F4A and/or Chart F4B. The testing to be performed and the sample size shall be as stipulated in the Purchase Order.

When procurement of more than one component type is involved from a family, range or series, the selection of representative samples shall also be stipulated in the Purchase Order.

## 7.4 FAILURE CRITERIA

The following criteria shall apply to qualification, qualification maintenance and Lot Validation Testing.

### 7.4.1 Environmental and Mechanical Test Failure

The following shall be counted as component failures:

- Components which fail during tests for which the pass/fail criteria are inherent in the test method, e.g. Vibration, Permanence of Marking, Temperature Cycling, Radiographic Inspection, External Visual Inspection, etc.

#### 7.4.2 Electrical Failure

The following shall be counted as component failures:

- Components which fail one or more of the applicable limits at each of the relevant data points specified for testing in Room Temperature Electrical Measurements, High and Low Temperatures Electrical Measurements or Intermediate and End-Point Electrical Measurements in the Detail Specification.

#### 7.4.3 Other Failures

A component shall be counted as a failure in any of the following cases:

- Visual failure.
- Mechanical failure.
- Handling failure.
- Lost component.

#### 7.5 FAILED COMPONENTS

A component shall be considered as failed if it exhibits one or more of the failure modes detailed in Para. 7.4.

In the event of any failure during Charts F4A or F4B, the Manufacturer shall act in accordance with Para. 4.3.3.

When requested by the ESCC Executive (for qualification, qualification maintenance or procurement of qualified components) or the Orderer (for procurement of qualified or unqualified components), failure analysis of failed components shall be performed under the responsibility of the Manufacturer and the results provided.

Failed components shall be retained at the Manufacturer's plant until the final disposition has been agreed and certified.

#### 7.6 QUALIFICATION, PERIODIC TESTING AND LOT VALIDATION TESTING SAMPLES

All tests of Charts F4A and F4B are considered to be destructive and therefore components so tested shall not form part of the delivery lot.

#### 7.7 DOCUMENTATION

Documentation of Qualification, Periodic Testing and Lot Validation Testing shall be in accordance with Para. 9.8.

**8 TEST METHODS AND PROCEDURES**

If a Manufacturer elects to eliminate or modify a test method or procedure, the Manufacturer is still responsible for delivering components that meet all of the performance, quality and reliability requirements defined in this specification and the Detail Specification.

For a qualified component, documentation supporting the change shall be approved by the ESCC Executive and retained by the Manufacturer. It shall be copied, when requested, to the ESCC Executive. The change shall be specified in an appendix to the Detail Specification and in the PID.

For an unqualified component, the change shall be approved by the Orderer. The change may be specified in an appendix to the Detail Specification at the request of the Manufacturer or Orderer, subject to the approval of the ESCC Executive.

**8.1 TEST VEHICLES FOR QUALIFICATION, PERIODIC TESTING AND LOT VALIDATION TESTING**

Unless otherwise specified in the Detail Specification, the RF cable assemblies submitted to Qualification, Periodic Testing and Lot Validation Testing (Charts F4A and F4B) shall include 2 additional connectors that each mate with the RF cable assembly connectors. The connectors shall be mated in the nominal manner as defined in the Detail Specification. These connectors shall be receptacles or plugs compatible with the RF cable assembly connectors (i.e. same connector interface definition). Some marks shall be applied to both connector sets in order to detect any relative movement of either of the RF cable assembly connectors during testing. Test vehicle configuration and test set-up shall be as shown in Figure 1.

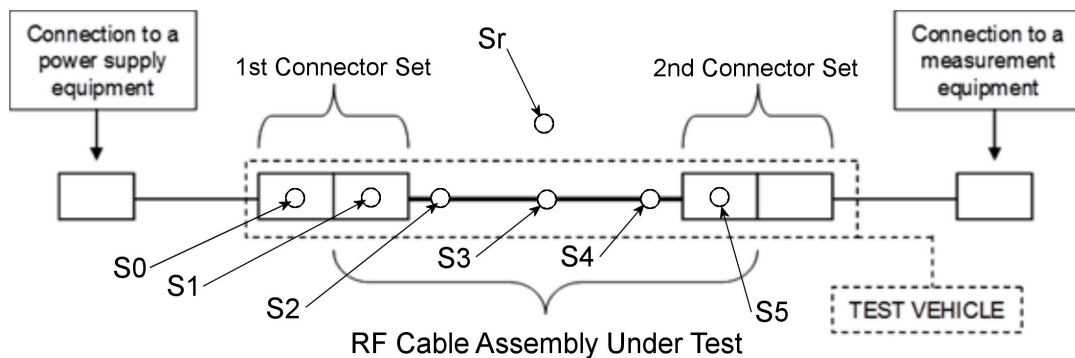

**FIGURE 1 - TEST VEHICLE CONFIGURATION**

Unless otherwise specified in the Detail Specification, the test vehicles shall be of minimum total length 1m.

The electrical connection between the power supply equipment and the first connector set or between the measurement equipment and the second connector set shall not disrupt the performance of the test vehicle.

The test set-up to be used for performing thermal measurements on the test vehicle shall include thermal sensors as indicated in Figure 1. A minimum of 6 thermal sensors shall be applied on the test vehicle (S0 to S5). The thermal sensor applied on the input connector (S0) shall represent the conductive temperature. 1 additional thermal sensor shall be glued to the base-plate of the set-up (Sr); it shall represent the radiative temperature. Temperature of the base-plate (Sr) should be monitored during testing, when applicable.

Precautions shall be taken during mounting of temperature sensors to avoid any issues during test under vacuum such as outgassing, removal of the sensors, etc.

## 8.2 CONTACT CAPABILITY

Only applicable to connectors with female contacts or with male contacts where the male contact deforms to make and retain electrical contact.

Contact Capability shall be performed prior to assembly on a sample of 13 contacts from each contact lot used in the RF cable assembly. In the event of any failure, the contact lot shall be rejected.

The contacts shall pick up the minimum weight and drop the maximum weight. These weights shall be as specified in the RF cable assembly Detail Specification.

## 8.3 GOLD PLATE POROSITY

Gold Plate Porosity shall be performed on connectors (contacts) prior to assembly, in accordance with Gold Plate Porosity as specified in ESCC Generic Specification No. [3402](#). The same sampling shall apply. In the event of any failure, the contact lot shall be rejected.

## 8.4 PLATING THICKNESS

Plating Thickness shall be measured on connectors prior to assembly, in accordance with Plating Thickness as specified in ESCC Generic Specification No. [3402](#) and the RF cable assembly Detail Specification. The same sampling shall apply. In the event of any failure, the contact or connector lot, as applicable, shall be rejected.

## 8.5 MAGNETISM LEVEL

Only required if specified in the RF cable assembly Detail Specification.

Magnetism Level shall be performed on a sample of 3 connectors from each lot used in the RF cable assembly prior to assembly, with contacts installed. In the event of any failure, a 100% measurement shall be performed. Any connectors failing to meet the Magnetism Level requirements shall be rejected.

The connectors' magnetism shall be measured in a magnetically 'quiet' area where machines, electronic equipment, vehicles and personnel traffic are restricted.

The connectors shall be passed through a known magnetic field three times. The magnetic field strength shall be approximately 5000 Gauss. If a coil is used to generate the magnetic field, the connector shall not make contact with the coil. The connectors' magnetism shall then be measured and shall meet the applicable requirements of the RF cable assembly Detail Specification.

## 8.6 PRE-ASSEMBLY VISUAL INSPECTION AND DIMENSION CHECK

Prior to assembly, the connector and cable add-on components used in the RF cable assemblies shall be inspected in accordance with the requirements of ESCC Basic Specification No. [20500](#).

Dimension Check shall be performed in accordance with ESCC Basic Specification No. [20500](#), the RF cable assembly Detail Specification and the applicable add-on component detail specifications. Dimension Check is not required to be repeated if performed as part of the Manufacturer's incoming inspection.

Any add-on components failing to meet the inspection requirements shall be rejected.

#### 8.7 INSULATION FLAWS (SPARK TEST)

The test shall be performed by the cable Manufacturer on the cable core prior to application of the outer conductor and jacket.

100% of the cable core shall pass a spark test without breakdown, performed in order to detect any insulation flaws in the dielectric. Applied voltage and frequency shall be as specified in the RF cable assembly Detail Specification.

In the event of any failure, the failed section of the cable core shall be separated from the cable length and rejected. The remaining length of cable core shall be retested until no further insulation flaws are detected.

#### 8.8 MICROSECTIONING OF STRANDS

Microsectioning of Strands shall be performed on cable prior to assembly, in accordance with Microsectioning of Strands as specified in ESCC Generic Specification No. [3902](#). The same sampling shall apply. In the event of any failure, the cable lot shall be rejected.

If other than silver coated copper strands are used, the requirements for Microsectioning of Strands shall be as specified in the RF cable assembly Detail Specification.

#### 8.9 ANTHONY AND BROWN TEST

Only applicable to RF cable assemblies that use silver plated cable, as specified in the RF cable assembly Detail Specification.

Unless otherwise specified, the Anthony and Brown Test shall only be performed if the cable lot is intended to be used to manufacture the RF cable assembly test vehicles used for Qualification Testing, Periodic Testing or Lot Validation Testing. In any case, the test shall not be performed on ESCC qualified cable lots.

Anthony and Brown Test shall be performed on cable prior to assembly, in accordance with Anthony and Brown Test as specified in ESCC Generic Specification No. [3902](#). The same sampling shall apply. In the event of any failure, the cable lot shall be rejected.

#### 8.10 COATING TESTS

Unless otherwise specified in the RF cable assembly Detail Specification, Coating Tests shall be performed once on each cable lot prior to assembly, in accordance with Coating Tests as specified in ESCC Generic Specification No. [3902](#). The same sampling shall apply. In the event of any failure, the cable lot shall be rejected.

#### 8.11 ADHESION OF INNER CONDUCTOR

Adhesion of Inner Conductor shall be performed once on each cable lot prior to assembly, in accordance with Adhesion of Inner Conductor as specified in ESCC Generic Specification No. [3902](#). The same sampling shall apply. In the event of any failure, the cable lot shall be rejected.

#### 8.12 DIELECTRIC STRENGTH OF JACKET

Only required if specified in the RF cable assembly Detail Specification.

Dielectric Strength of Jacket shall be performed on cable prior to assembly (on each length of finished cable), in accordance with Dielectric Strength of Jacket as specified in ESCC Generic Specification No. 3902. Test voltage and frequency shall be as specified in the RF cable assembly Detail Specification. In the event of any failure, the failed cable length shall be rejected.

#### 8.13 CONDUCTOR RESISTANCE

Conductor Resistance shall be measured once on each cable lot prior to assembly, in accordance with Conductor Resistance as specified in ESCC Generic Specification No. 3902 and the RF cable assembly Detail Specification. In the event of any failure, the cable lot shall be rejected.

#### 8.14 CAPACITANCE

Capacitance shall be measured on cable prior to assembly, in accordance with Capacitance as specified in ESCC Generic Specification No. 3902 and the RF cable assembly Detail Specification. In the event of any failure, the cable lot shall be rejected.

#### 8.15 CHARACTERISTIC IMPEDANCE

Characteristic Impedance shall be measured on cable prior to assembly, in accordance with Characteristic Impedance as specified in ESCC Generic Specification No. 3902 and the RF cable assembly Detail Specification. The same sampling shall apply. In the event of any failure, the cable lot shall be rejected.

#### 8.16 LENGTH AND WEIGHT (OF RF CABLE ASSEMBLY)

Length and weight of the RF cable assembly shall be measured and shall meet the requirements of the RF cable assembly Detail Specification.

#### 8.17 TEMPERATURE CYCLING

##### 8.17.1 During Screening Tests (Chart F3)

Unless otherwise specified, the following conditions shall apply:

- Number of Temperature Cycles: 3 cycles minimum with 15 minutes minimum at each storage temperature extreme as specified in Maximum Ratings in the Detail Specification.
- Temperature transfer slope:  $\leq 10^{\circ}\text{C/minute}$

## 8.17.2 During Qualification Testing, Periodic Testing and Lot Validation Testing (Chart F4A)

### 8.17.2.1 *Temperature Cycling I*

Only required if specified in the Detail Specification.

Unless otherwise specified, the following conditions shall apply:

- Number of Temperature Cycles: 25 cycles with 15 minutes minimum at each storage temperature extreme as specified in Maximum Ratings in the Detail Specification.
- Temperature transfer slope:  $\leq 10^{\circ}\text{C}/\text{minute}$
- Data Points:  
On completion of testing and after a recovery period of 2 hours minimum at room temperature conditions, the test vehicles shall be visually examined and there shall be no evidence of damage or loosening of parts.

VSWR and Insertion Loss shall be measured at  $T_{\text{amb}} = +22 \pm 3^{\circ}\text{C}$  as specified in Intermediate and End-Point Electrical Measurements in the Detail Specification. If parameter drift is specified, initial measurements also shall be performed and parameter drift calculated.

### 8.17.2.2 *Temperature Cycling II*

Unless otherwise specified, the following conditions shall apply:

- Number of Temperature Cycles: 200 cycles with 15 minutes minimum at each storage temperature extreme as specified in Maximum Ratings in the Detail Specification.
- Temperature transfer slope:  $\leq 10^{\circ}\text{C}/\text{minute}$
- Data Points:  
On completion of testing and after a recovery period of 2 hours minimum at room temperature conditions, the test vehicles shall be visually examined and there shall be no evidence of damage or loosening of parts.

VSWR and Insertion Loss shall be measured at  $T_{\text{amb}} = +22 \pm 3^{\circ}\text{C}$  as specified in Intermediate and End-Point Electrical Measurements in the Detail Specification. If parameter drift is specified, initial measurements also shall be performed and parameter drift calculated.

## 8.17.3 During Periodic Testing and Lot Validation Testing (Chart F4B)

Unless otherwise specified, the following conditions shall apply:

- Number of Temperature Cycles: 100 cycles with 15 minutes minimum at each storage temperature extreme as specified in Maximum Ratings in the Detail Specification.
- Temperature transfer slope:  $\leq 10^{\circ}\text{C}/\text{minute}$
- Data Points:  
On completion of testing and after a recovery period of 2 hours minimum at room temperature conditions, the test vehicles shall be visually examined and there shall be no evidence of damage or loosening of parts.

VSWR and Insertion Loss shall be measured at  $T_{\text{amb}} = +22 \pm 3^{\circ}\text{C}$  as specified in Intermediate and End-Point Electrical Measurements in the Detail Specification. If parameter drift is specified, initial measurements also shall be performed and parameter drift calculated.

### 8.18 COUPLING PROOF TORQUE

Coupling Proof Torque shall be performed in accordance with Coupling Proof Torque as specified in ESCC Generic Specification No. 3402 and the RF cable assembly Detail Specification. Both connectors in each RF cable assembly shall be tested.

For Screening Tests (Chart F3), Coupling Proof Torque shall be performed on samples selected at random from the cable assembly lot in accordance with the sampling indicated in the table below. In the event of any failure, a 100% test shall be performed.

Cable Assembly Lot Size	Sampling
2 to 15	2
16 to 25	3
26 to 90	5
91 to 150	8
151 to 280	13
281 to 500	20
501 to 1200	32
1201 to 3200	50
3201 to 10000	80

### 8.19 MATING AND UNMATING FORCES

#### 8.19.1 During Screening Tests (Chart F3)

Not applicable to RF cable assemblies with bayonet and screw coupling connectors.

Mating and Unmating Forces shall be performed in accordance with Mating and Unmating Forces as specified in ESCC Generic Specification No. 3402 and the RF cable assembly Detail Specification, on samples selected at random from the cable assembly lot in accordance with the sampling indicated in the table below. Both connectors in each RF cable assembly shall be tested. In the event of any failure, a 100% test shall be performed.



Cable Assembly Lot Size	Sampling
2 to 15	2
16 to 25	3
26 to 90	5
91 to 150	8
151 to 280	13
281 to 500	20
501 to 1200	32
1201 to 3200	50
3201 to 10000	80

8.19.2 During Qualification, Periodic Testing and Lot Validation Testing (Charts F4A and F4B)

This test may be performed on unassembled connectors. In which case, the connectors must originate from the same connector lot as those used in the cable assembly lot.

Mating and Unmating Forces shall be performed in accordance with Mating and Unmating Forces as specified in ESCC Generic Specification No. 3402 and the RF cable assembly Detail Specification. Both connectors in each cable assembly shall be tested. During each mating/unmating cycle (until the component is fully mated or unmated), the necessary torque shall not exceed the value specified in the ESCC Detail Specification. Unless otherwise specified, the number of mating/unmating cycles shall be 50.

8.20 ELECTRICAL MEASUREMENTS

8.20.1 General

All test equipment shall have the same characteristic impedance as the RF cable assembly under test.

ESCC qualified connector savers may be used for performance of electrical tests to minimise the number of mating and unmating cycles. The effect of the savers on the measurements shall be taken into account.

Where a parameter is specified over a frequency range, a plot of the parameter over the frequency range shall be produced.

8.20.1.1 *Dielectric Withstanding Voltage / Voltage Proof Leakage Current*

[MIL-STD-202, Test Method 301](#) and as follows:

- Relative Humidity:  $\leq 50\%$ .
- The test voltage, points of application of the test voltage shall be as specified in the Detail Specification.
- The test voltage shall be applied for 1 minute.
- There shall be no evidence of flashover or breakdown.
- Voltage Proof Leakage Current shall meet the limits specified in the Detail Specification.

#### 8.20.1.2 *Insulation Resistance*

Unless otherwise specified, Insulation Resistance shall not be measured during Screening Tests (Chart F3).

[MIL-STD-202, Test Method 302](#) and as follows:

- Test Voltage: 500Vdc.
- Points of Measurement: Between the connector centre contact(s) and the body of the test vehicle. All contacts shall be tested.
- Measurement shall be read after 1 minute of voltage application.
- Insulation Resistance shall meet the limits specified in the Detail Specification.

#### 8.20.1.3 *Voltage Standing Wave Ratio (VSWR)*

VSWR on each connector shall be measured using an appropriate test method employing a suitable coaxial test set-up, across the full frequency range by a swept frequency. The following conditions shall apply:

- Applied Power: Low level RF power as specified in the Detail Specification.
- Operating Frequency: Over the full operating frequency range as specified in the Detail Specification.
- VSWR shall meet the limits specified in the Detail Specification.

#### 8.20.1.4 *Insertion Loss*

Insertion Loss shall be measured using an appropriate test method employing a suitable coaxial test set-up, across the full frequency range either by a swept frequency technique or, alternatively, at a minimum of 7 fixed frequencies equally spaced across the frequency range. The following conditions shall apply:

- Operating Frequency: Over the full operating frequency range as specified in the Detail Specification.
- Insertion Loss shall meet the limits specified in the Detail Specification.

#### 8.20.2 Room Temperature Electrical Measurements

Room Temperature Electrical Measurements shall be performed as specified in the Detail Specification. Unless otherwise specified, Dielectric Withstanding Voltage, Voltage Proof Leakage Current, VSWR and Insertion Loss shall be measured at  $T_{amb} = +22 \pm 3^{\circ}\text{C}$ . All values obtained shall be recorded against serial numbers.

#### 8.20.3 Intermediate and End-Point Electrical Measurements

At each of the relevant data points during Qualification, Periodic Testing and Lot Validation Testing (Charts F4A and F4B), Intermediate and End-Point Electrical Measurements shall be performed as specified herein and in the Detail Specification. All values obtained shall be recorded against serial numbers and the parameter drift calculated if specified.

#### 8.20.4 Electrical Measurements at Room, High and Low Temperatures

At each of the relevant data points during Qualification, Periodic Testing and Lot Validation Testing (Charts F4A and F4B), unless otherwise specified, Dielectric Withstanding Voltage, Voltage Proof Leakage Current, Insulation Resistance, VSWR and Insertion Loss shall be measured as specified in Intermediate and End-Point Electrical Measurements in the Detail Specification. Measurements shall be performed at  $T_{amb} = +22 \pm 3^{\circ}\text{C}$ , and at maximum and minimum operating temperatures as specified in Maximum Ratings in the Detail Specification. All values obtained shall be recorded against serial numbers.

#### 8.21 MULTIPLICATION

Only required if specified in the Detail Specification.

A multiplication test shall be performed in accordance with ECSS-E-20-01. The multiplication classification of component type shall be as specified in the Detail Specification. Unless otherwise specified, the following conditions shall apply:

- Applied Power: Rated RF pulse power as specified in Maximum Ratings in the Detail Specification.
- Test Temperatures: Minimum and maximum operating temperatures as specified in Maximum Ratings in the Detail Specification.
- Operating Frequency: As specified in Detail Specification
- Data Points:  
For Screening Tests only (Chart F3), on completion of testing and after a recovery period of 2 hours minimum at room temperature conditions, electrical measurements as specified in Room Temperature Electrical Measurements in the Detail Specification shall be performed.

#### 8.22 RADIOGRAPHIC INSPECTION

ESCC Basic Specification No. [20900](#) and the following requirements:

Radiographic examination shall be performed on both cable-to-connector connections for each RF cable assembly.

As a minimum, radiographs of solder joints shall be taken perpendicularly to the centreline of the connectors as follows:

- The solder joint between the outer conductor of the cable and the connector body, if one exists.
- The solder joint between the centre conductor of the cable and the centre conductor of the connector, if one exists.

The radiographs shall be examined against the following acceptance criteria:

- There shall be no evidence of solder projections, spikes, splashes or loose particles.
- Centre conductor:
  - The centre conductor of the cable shall be inserted into the contact hole for a minimum of 80% of the cavity length.
  - The centre conductor of the cable shall present a straight shape in the connector.
  - The solder in the joint between the pin and the cable centre conductor shall show a maximum of 30% voids within the solder joint.
  - The solder in the joint between the pin and the cable centre conductor shall not show a single void bigger than 25% within the solder joint

- Outer conductor:
  - The outer conductor shall be inserted into the connector body or ferrule with a minimum of 70% of dedicated length.
  - The outer conductor to connector body joint shall show a maximum of 30% voids within the solder joint
  - The outer conductor to connector body joint shall not show a single void bigger than 25% within the solder joint.
- Any bend of the cable in 90° connector types shall be smooth and continuous, with uniform foil overlap and braid lay.

#### 8.23 RF INTERFACE GAUGING

The RF interface shall be checked on each connector of each RF cable assembly using suitable gauges in accordance with the RF cable assembly Detail Specification.

#### 8.24 EXTERNAL VISUAL INSPECTION

External Visual Inspection shall be performed in accordance with ESCC Basic Specification No. 20500 with magnification power x10.

#### 8.25 SHIELDING EFFECTIVENESS

Shielding Effectiveness (SE) shall be measured in accordance with IEC Publication No. 61726 and the following requirements:

- Maximum frequency range of the reverberant chamber shall not be less than the maximum operating frequency of the test vehicles.
- Number of measurement points: 100 points/decade.
- Shielding Effectiveness shall meet the limits specified in Intermediate and End-Point Electrical Measurements in the Detail Specification.

The Shielding Effectiveness (SE) is calculated using the following formula:

$$SE \text{ (dB)} = (P_i/P_t) \text{ (dB)} - X_c$$

Where :

- $P_i$  is the incident power (from the generator)
- $P_t$  is the transmitted power to the test vehicles
- $X_c$  is the cage loss (dB).  $X_c$  is measured with an additional matched antenna in the reverberation chamber.

#### 8.26 CABLE RETENTION FORCE

The test vehicles shall be held vertically and fixed such that the forces and torques to be applied will not cause it to move. The cable of the test vehicles shall be kept as unbent and untwisted as possible.

The connector at one end of each test vehicle shall be held while an axial force is applied to the connector at the other end, along the cable axis, by suitable means. The force shall be gradually increased until the cable retention force specified in the Detail Specification is attained. The cable retention force shall then be applied for 2 minutes.

- Data Points:  
Prior to testing, Interface dimensions shall be checked as specified in Para. 8.23 herein and VSWR shall be measured at  $T_{amb} = +22 \pm 3^{\circ}\text{C}$  as specified in Intermediate and End-Point Electrical Measurements in the Detail Specification.

On completion of testing, the test vehicles shall be visually inspected and there shall be no evidence of mechanical damage, loosening of the cable or rupture. Interface dimensions shall be rechecked, and VSWR and Insertion Loss shall be measured at  $T_{amb} = +22 \pm 3^{\circ}\text{C}$  as specified in Intermediate and End-Point Electrical Measurements in the Detail Specification.

## 8.27 RADIATION

Only required if specified in the Detail Specification.

The test vehicle shall be subjected to a radiation test in accordance with the following conditions:

- Mounting:  
Test set-up atmosphere shall exclude oxygen (i.e. tested under continuous Nitrogen flow or in vacuum).  
  
Test set-up shall be implemented so that the test vehicle temperature (at sensors S1 to S5) during testing is limited to  $\leq +40^{\circ}\text{C}$ .
- Ambient test temperature during irradiation:  $T_{amb} = +20 \pm 10^{\circ}\text{C}$ .
- Radiation source: electron or gamma
- Radiation dosage: as specified in the Detail Specification.
- Dose rate:  $\leq 45\text{MRAD/hour}$
- Data Points:  
Prior to testing, VSWR and Insertion Loss shall be measured at  $T_{amb} = +22 \pm 3^{\circ}\text{C}$  as specified in Intermediate and End-Point Electrical Measurements in the Detail Specification.

On completion of testing and after a recovery period of 2 hours minimum at room temperature conditions, the test vehicle shall be visually inspected. There shall be no evidence of damage or loosening of parts. Unless otherwise specified, Dielectric Withstanding Voltage, Voltage Proof Leakage Current, Insulation Resistance, VSWR and Insertion Loss shall be measured at  $T_{amb} = +22 \pm 3^{\circ}\text{C}$  as specified in Intermediate and End Point Electrical Measurements in the Detail Specification.

### **NOTES:**

1. For qualified RF cable assemblies, the radiation source and the radiation dosage shall be approved by ESCC Executive prior to testing.
2. For electron source radiation, the following conditions shall apply:  
The electron source used for the test shall be a steady-state type. The electron energy shall be sufficient to guarantee 1 to 3 MeV energy remaining at the test samples.
3. For qualified RF cable assemblies, the radiation cumulated dose shall be approved by the ESCC Executive.
4. For gamma source radiation, the following test procedure shall apply :
  - (a) Dielectric dosage level:
    - Irradiate to dielectric dosage level as specified in the Detail Specification.
    - On completion of testing and after a recovery period of 2 hours minimum at room temperature conditions, Insertion Loss, Change of Insertion Loss, VSWR and

change of VSWR shall be measured as a minimum, at  $T_{amb} = +22 \pm 3^{\circ}\text{C}$ , as specified in Intermediate and End Point Electrical Measurements in the Detail Specification.

Note: Flexing of the cable of the test vehicle during testing shall be avoided.

(b) Cable Jacket dosage level:

- Irradiate to cable jacket dosage level as specified in the Detail Specification.
- On completion, as a minimum inspect for integrity of the cable jacket material (both at magnification power x1 and minimum x10). There shall be no cracking, no particles of the cable jacket material flaking away.

8.28 AGEING

[MIL-STD-202, Test Method 108](#) (non-operating) and as follows:

- Test Temperature: maximum storage temperature specified in Maximum Ratings in the Detail Specification
- Duration: 240h
- Data Points:  
On completion of testing and after a recovery period of 2 hours minimum at room temperature conditions, VSWR and Insertion Loss shall be measured at  $T_{amb} = +22 \pm 3^{\circ}\text{C}$  as specified in Intermediate and End-Point Electrical Measurements in the Detail Specification.

8.29 MATING ENDURANCE

Mating Endurance shall be performed in accordance with Endurance as specified in ESCC Generic Specification No. [3402](#), and as follows:

- Cycle Rate:  $\leq 12/\text{minute}$
- Number of Mating/Unmating Cycles: 50

One connector of each connector type in each test vehicle shall be tested.

**NOTE:**

Unless otherwise specified, the threads of rotational parts shall not be lubricated before or during Mating Endurance testing. Solvents and tools shall not be used for cleaning.

8.30 BENDING

The centre section of the cable of the test vehicles shall be wrapped entirely around a mandrel having a diameter equal to the minimum bending radius defined in the Detail Specification. First wrap shall be against the natural flow of the cable. Then second wrap shall be done according to the natural flow. Then wrapping shall be done alternatively to a total of 2 times in each direction.

- Data Points:  
On completion of testing, the test vehicles shall be visually inspected. There shall be no cracks, flaws or other damage in the cable jacket material. VSWR and Insertion Loss shall be measured at  $T_{amb} = +22 \pm 3^{\circ}\text{C}$  as specified in Intermediate and End-Point Electrical Measurements in the Detail Specification.

### 8.31 VIBRATION (RANDOM AND SINE)

Test vehicles shall be subjected to both Random Vibration and Sine Vibration tests. The tests may be performed in any order.

Each complete test vehicle including both connector sets shall be mounted on the vibration generator either directly or by means of a fixture. The outer connector of each connector set shall be mounted rigidly on the vibration generator or fixture, as applicable.

The cable of each test vehicle shall be secured to the vibration-plate using 2.5 ±0.5mm wide cable-ties looped through aluminium tie-down posts starting 200 (+25 -0)mm from the reference plane or centreline of the mated connector sets and every 200mm minimum thereafter. Appropriate protective padding shall be placed between the cable jacket and tie down plates to prevent damage to the cable.

Mounting fixtures shall enable each test vehicle to be vibrated in 3 mutually perpendicular axes in turn, which should be so chosen that faults are most likely to be revealed.

#### 8.31.1 Random Vibration

[MIL-STD-202, Test Method 214](#). Unless otherwise specified, the following conditions shall apply:

- Random Vibration Test Curve:

Envelope: Grms = 38.5	
20 to 60 Hz	+6dB/Octave
60 to 400 Hz	2g <sup>2</sup> /Hz
400 to 800 Hz	-6dB/Octave
800 to 1000 Hz	0.5g <sup>2</sup> /Hz
1000 to 2000 Hz	-6dB/Octave

- Duration: 180s in each of the 3 mutually perpendicular axes.
- Electrical continuity shall be monitored continuously during the test. No discontinuities > 1µs are allowed.
- Data Points:  
On completion of testing, the test vehicles shall be visually inspected. There shall be no evidence of damage or loosening of parts. VSWR and Insertion Loss shall be measured at T<sub>amb</sub> = +22 ±3°C as specified in Intermediate and End-Point Electrical Measurements in the Detail Specification.

#### 8.31.2 Sine Vibration

[MIL-STD-202, Test Method 204](#). Unless otherwise specified, the following conditions shall apply:

- Sweep Frequency: 5-100-5Hz. For the entire frequency range of 5 to 100Hz and return to 5Hz, the slope rate shall be 2 Octaves per minute maximum.
- Total number of Cycles: 9 (3 times in each of the 3 mutually perpendicular axes).
- Vibration Amplitude:
  - 5Hz to 26Hz: 11mm (peak)
  - 26Hz to 100Hz: 30g
- Data Points:  
On completion of testing, the test vehicles shall be visually inspected. There shall be no evidence of damage or loosening of parts. VSWR and Insertion Loss shall be measured at



$T_{amb} = +22 \pm 3^{\circ}\text{C}$  as specified in Intermediate and End-Point Electrical Measurements in the Detail Specification.

### 8.32 CORONA

Only required if specified in the Detail Specification.

Test vehicles shall be subjected to corona testing under thermal vacuum in accordance with the following conditions:

- **Mounting:**  
The test vehicles shall be mounted in a thermal vacuum chamber by means of a port-plate. The chamber shall be filled with air or dry nitrogen. Precautions shall be taken to avoid any condensation during testing.
- **Test Conditions:**
  - Test temperature shall be  $+22 \pm 3^{\circ}\text{C}$  (at sensor Sr).
  - The maximum RF power level without corona breakdown as specified in the Detail Specification shall be applied.
  - Operating frequency: 1GHz, CW mode.
  - Vacuum pumping sequence: start pumping from ambient pressure, while RF power is ON. Once the pressure in the vacuum chamber has reached 5mPa, maintain the RF power for a duration of 1 hour.
- **Data Points:**  
During testing, Insertion Loss and VSWR shall be continuously monitored and recorded once every 500ms as a minimum or alternatively an analogue recorder may be used. Measurements shall meet the limits specified in Intermediate and End-Point Electrical Measurements in the Detail Specification.

During testing, the test vehicles shall be continuously monitored and there shall be no corona breakdown/discharge. Corona breakdown/discharge shall be detected using an appropriate method (e.g. Global method based on the RF signal analysis: Transmit power, Reflected power, 3rd harmonic, phase nulling, Close-to-carrier noise; Local methods: Optical detection, Electron probe). For qualified RF cable assemblies, the detection method shall be agreed by the ESCC Executive.

On completion of testing and after a recovery period of 2 hours minimum at room temperature conditions, unless otherwise specified, Dielectric Withstanding Voltage, Voltage Proof Leakage Current, Insulation Resistance, VSWR and Insertion Loss shall be measured at  $T_{amb} = +22 \pm 3^{\circ}\text{C}$  as specified in Intermediate and End-Point Electrical Measurements in the Detail Specification.

### 8.33 RF POWER HANDLING

Only required if specified in the Detail Specification.

Test vehicles shall be subjected to an RF power handling test under thermal vacuum in accordance with the following requirements:

- **Mounting:**  
Test vehicles shall be mounted in a vacuum chamber on thermally conductive brackets. Precaution shall be taken to avoid thermal conduction of the cable through the base plate. Poor thermally conductive stand-off supports are recommended to hold the cable.



Temperature of the base plate should be monitored when applicable. For qualified RF cable assemblies, the mounting set-up shall be approved by the ESCC Executive.

- **Pre-test Venting:**  
Unless otherwise specified, the test vehicles shall be vented for the purpose of outgassing, for a minimum duration of 24 hours prior to application of RF power, in a vacuum of  $\leq 1\text{mPa}$ , at  $T_{\text{amb}} = +100^{\circ}\text{C}$ .
- **Test Conditions:**
  - Test temperature: As specified in the Detail Specification (at sensor Sr).
  - Test pressure:  $\leq 1\text{mPa}$ .
  - After thermal stabilisation of the test vehicles at the test temperature, rated RF power as specified in the Detail Specification shall be applied.
  - Operating Frequency: the maximum operating frequency as specified in the Detail Specification, unless otherwise specified.
  - Test duration: 6 hours.
- **Data Points:**  
During testing, the temperature of the test vehicles shall be continuously monitored (at sensors S1 to S5) to ensure there is no thermal runaway. Temperature stabilisation shall be considered achieved if the change in temperature of each test vehicle during the test, after the initial thermal stabilisation at the test temperature, is less than  $10^{\circ}\text{C}$ . In addition, at no time during testing should the temperature of the test vehicles exceed the maximum operating temperature as specified in Maximum Ratings in the Detail Specification.

During testing, Insertion Loss and VSWR shall be continuously monitored and recorded once every 500ms as a minimum or alternatively an analogue recorder may be used. Measurements shall meet the limits specified in Intermediate and End-Point Electrical Measurements in the Detail Specification.

On completion of testing and after a recovery period of 2 hours minimum at room temperature conditions, unless otherwise specified, Dielectric Withstanding Voltage, Voltage Proof Leakage Current, Insulation Resistance, VSWR and Insertion Loss shall be measured at  $T_{\text{amb}} = +22 \pm 3^{\circ}\text{C}$  as specified in Intermediate and End-Point Electrical Measurements in the Detail Specification.

#### 8.34 RF POWER CYCLING

Only required if specified in the Detail Specification.

Test vehicles shall be subjected to an RF power cycling test under thermal vacuum in accordance with the following conditions:

- **Mounting:**  
Test vehicles shall be mounted in a vacuum chamber on thermally conductive brackets. Precaution shall be taken to avoid thermal conduction of the cable through the base plate. Poor thermally conductive stand-off supports are recommended to hold the cable. Temperature of the base plate should be monitored when applicable. For qualified RF cable assemblies, the mounting set-up shall be approved by the ESCC Executive.
- **Pre-test Venting:**  
Unless otherwise specified, the test vehicles shall be vented for the purpose of outgassing, for a minimum duration of 24 hours prior to application of RF power, in a vacuum of  $\leq 1\text{mPa}$ , at  $T_{\text{amb}} = +100^{\circ}\text{C}$ .

- Test Conditions:
  - Test temperature: As specified in the Detail Specification (at sensor Sr).
  - Test pressure:  $\leq 1\text{mPa}$ .
  - After thermal stabilisation of the test vehicles at the test temperature, RF power as specified in the Detail Specification shall be applied in cycles as follows:
    - Number of OFF/ON cycles: 6
    - During each OFF period: no RF power shall be applied.
    - During each ON period: the specified RF power shall be applied as quickly as possible.
    - Operating frequency: As specified in Detail Specification.
    - Test duration during each OFF period: 15 minutes after temperature stabilisation.
    - Test duration during each ON period: 15 minutes after temperature stabilisation.

- Data Points:

During testing, Insertion Loss and VSWR shall be shall be continuously monitored and recorded once every 500ms as a minimum or alternatively an analogue recorder may be used. Measurements shall meet the limits specified in Intermediate and End-Point Electrical Measurements in the Detail Specification.

During testing, the test vehicles shall be monitored and there shall be no corona breakdown/discharge. Corona breakdown/discharge shall be detected using an appropriate method (e.g. Global method based on the RF signal analysis: Transmit power, Reflected power, 3rd harmonic, phase nulling, Close-to-carrier noise; Local method: Optical detection, Electron probe). For qualified RF cable assemblies, the detection method shall be agreed by the ESCC Executive.

On completion of testing and after a recovery period of 2 hours minimum at room temperature conditions, unless otherwise specified, Dielectric Withstanding Voltage, Voltage Proof Leakage Current, Insulation Resistance, VSWR and Insertion Loss shall be measured at  $T_{\text{amb}} = +22 \pm 3^{\circ}\text{C}$  as specified in Intermediate and End-Point Electrical Measurements in the Detail Specification.

### 8.35 THERMAL STABILITY OF INSERTION LOSS

Test vehicles shall be subjected to temperature cycling with the following conditions:

- Number of Temperature Cycles: 3 cycles with 15 minutes minimum at each operating temperature extreme as specified in Maximum Ratings in the Detail Specification.
- Temperature transfer slope:  $3 \pm 1^{\circ}\text{C}/\text{minute}$
- Power Applied During Cycling: 0dBm minimum.
- Operating Frequency: the maximum operating frequency as specified in the Detail Specification, unless otherwise specified.
- Data Points:

During testing, Insertion Loss shall be continuously monitored and recorded once every 500ms as a minimum or alternatively an analogue recorder may be used. The following acceptance criteria shall apply:

  - No single Insertion loss discontinuity, step or spike shall exceed 0.1dB.

**NOTE:** In order for any observed glitch to be considered as a single Insertion Loss discontinuity, step or spike, it shall be evident on more than one temperature cycle. Otherwise it may be ignored.

8.36 CRIMP CONTACT TENSILE STRENGTH

Only required if specified in the Detail Specification.

All crimp contacts within the RF cable assembly shall be subjected to, and shall meet the requirements of the tensile strength test as specified in ECSS-Q-ST-70-26.

8.37 PERMANENCE OF MARKING

ESCC Basic Specification No. [24800](#).

8.38 DESTRUCTIVE PHYSICAL ANALYSIS (DPA)

ESCC Basic Specification No. [21001](#) on both the connectors and the cable of the RF Cable Assembly.

## 9 DATA DOCUMENTATION

### 9.1 GENERAL

For the qualification, qualification maintenance and procurement for each lot, a data documentation package shall exist in a printed or electronic form.

This package shall be compiled from:

- (a) Cover sheet (or sheets).
- (b) List of equipment (testing and measuring).
- (c) List of test references.
- (d) Add-on components documentation.
- (e) Special In-Process Controls data (Chart F2).
- (f) Screening Tests data (Chart F3).
- (g) Qualification, Periodic Testing and Lot Validation Testing (when applicable) data (Charts F4A and F4B).
- (h) Failed components list and failure analysis report (when applicable).
- (i) Certificate of Conformity.

Items (a) to (i) inclusive shall be grouped, preferably as subpackages and, for identification purposes, each page shall include the following information:

- ESCC Component Number.
- Manufacturer's name.
- Lot identification.
- Date of establishment of the document.
- Page number.

Whenever possible, documentation should preferably be available in electronic format suitable for reading using a compatible PC. The format supplied shall be legible, durable and indexed. The preferred storage medium is CD-ROM and the preferred file format is PDF.

#### 9.1.1 Qualification and Qualification Maintenance

In the case of qualification or qualification maintenance, the items listed in Para. 9.1(a) to (i) are required.

#### 9.1.2 Component Procurement and Delivery

For all deliveries of components procured to this specification, the following documentation shall be supplied:

- (a) Cover sheet (if all of the information is not included on the Certificate of Conformity).
- (b) Certificate of Conformity (including range of delivered serial numbers).

#### 9.1.3 Additional Documentation

The Manufacturer shall deliver additional documentation containing data and reports to the Orderer, if stipulated in the Purchase Order.

#### 9.1.4 Data Retention/Data Access

If not delivered, all data shall be retained by the Manufacturer for a minimum of 10 years during which time it shall be available for review, if requested, by the Orderer or the ESCC Executive (for qualified components).

## 9.2 COVER SHEET(S)

The cover sheet(s) of the data documentation package shall include as a minimum:

- (a) Reference to the Detail Specification, including issue and date.
- (b) Reference to the applicable ESCC Generic Specification, including issue and date.
- (c) ESCC Component Number and the Manufacturer's part type number.
- (d) Lot identification.
- (e) Range of delivered serial numbers.
- (f) Number of the Purchase Order.
- (g) Information relative to any additions to this specification and/or the Detail Specification.
- (h) Manufacturer's name and address.
- (i) Location of the manufacturing plant (specify place of assembly and test).
- (j) Signature on behalf of Manufacturer.
- (k) Total number of pages of the data package.

## 9.3 LIST OF EQUIPMENT USED

A list of equipment used for tests and measurements shall be prepared. Where applicable, this list shall contain inventory number, Manufacturer's type number, serial number, etc. This list shall indicate for which tests such equipment was used.

## 9.4 LIST OF TEST REFERENCES

This list shall include all Manufacturer's references or codes which are necessary to correlate the test data provided with the applicable tests specified in the tables of the Detail Specification.

## 9.5 ADD-ON COMPONENTS DOCUMENTATION

A summary of the results of procurement and screening of add-on components (with reference to the traceability information) shall be compiled and shall provide the following information for each add-on component type:

- Reference
- Supplier name and location
- Lot identification and date code
- Quality level
- Procurement specifications (Generic and Detail)
- Reliability data reference
- Certificate of Conformity

In addition, for cable add-on components (as applicable), a summary of the results of the Insulation Flaws (Spark Test) shall be included in the documentation, traceable to each length of cable supplied.

## 9.6 SPECIAL IN-PROCESS CONTROLS DATA (CHART F2)

A test result summary shall be compiled showing the total number of add-on components submitted to, and the total number rejected after each of the tests. For Plating Thickness the minimum and maximum measurements shall be provided.

### 9.7 SCREENING TESTS DATA (CHART F3)

A test result summary shall be compiled showing the total number of components submitted to and the total number rejected after each of the tests. For each test requiring electrical measurements, the results shall be recorded against component serial number. For Radiographic Inspection, all radiographs shall be recorded against component serial number.

### 9.8 QUALIFICATION, PERIODIC TESTING AND LOT VALIDATION TESTING DATA (CHARTS F4A AND F4B)

#### 9.8.1 Qualification Testing (Chart F4A)

A test result summary shall be compiled showing the components submitted to, and the number rejected after each test. Component serial numbers shall be identified. For each test requiring electrical measurements, the results shall be recorded against component serial number. Where a drift value is specified during a test the drift calculation shall be recorded against component serial number. For Radiographic Inspection, all radiographs shall be recorded against component serial number. For Destructive Physical Analysis, a DPA report shall be produced in accordance with ESCC Basic Specification No. [21001](#).

#### 9.8.2 Periodic Testing for Qualification Maintenance (Chart F4A or F4B)

A test result summary shall be compiled showing the components submitted to and the number rejected after each test. Component serial numbers shall be identified. For each test requiring electrical measurements, the results shall be recorded against component serial number. Where a drift value is specified during a test the drift calculation shall be recorded against component serial number. For Radiographic Inspection, all radiographs shall be recorded against component serial number. For Destructive Physical Analysis, a DPA report shall be produced in accordance with ESCC Basic Specification No. [21001](#).

In addition to the full test data, a report shall be compiled to act as the most recent Periodic Testing summary. This report shall include a list of all tests performed, the ESCC Component Numbers and quantities of components tested, a statement confirming all the results were satisfactory, the date the tests were performed and a reference to the full test data.

#### 9.8.3 Lot Validation Testing (Charts F4A and/or F4B)

A test result summary shall be compiled showing the components submitted to and the number rejected after each test (as applicable). Component serial numbers for each subgroup shall be identified. For each test requiring electrical measurements, the results shall be recorded against component serial number. Where a drift value is specified during a test the drift calculation shall be recorded against component serial number. For Radiographic Inspection, all radiographs shall be recorded against component serial number. For Destructive Physical Analysis, a DPA report shall be produced in accordance with ESCC Basic Specification No. [21001](#).

### 9.9 FAILED COMPONENTS LIST AND FAILURE ANALYSIS REPORT

The failed components list and failure analysis report shall provide full details of:

- (a) The reference and description of the test or measurement performed as defined in this specification and/or the Detail Specification during Special In-Process Controls, Screening Tests, and Qualification, Periodic Testing and Lot Validation Testing.
- (b) Traceability information including serial number (if applicable) of the failed component.
- (c) The failed parameter and the failure mode of the component.
- (d) Detailed failure analysis (if requested by the ESCC Executive or Orderer).

**9.10**     **CERTIFICATE OF CONFORMITY**

A Certificate of Conformity shall be established in accordance with the requirements of ESCC Basic Specification No. [20100](#).

**10**       **DELIVERY**

For procurement, for each order, the items forming the delivery are:

- (a) The delivery lot.
- (b) The components used for Lot Validation Testing (as applicable), but not forming part of the delivery lot, if stipulated in the Purchase Order.
- (c) The relevant documentation in accordance with the requirements of Paras. 9.1.2 and 9.1.3.

In the case of a component for which a valid qualification is in force, all data of all components submitted to Lot Validation Testing shall also be copied, when requested, to the ESCC Executive.

For qualification or qualification maintenance, the disposition of the Qualification Test Lot and its related documentation shall be as specified in ESCC Basic Specification No. [20100](#) and the relevant paragraphs of Section 0 of this specification.

**11**       **PACKAGING AND DISPATCH**

The packaging and dispatch of components to this specification shall be in accordance with the requirements of ESCC Basic Specification No. [20600](#).

**12 CHARTS**

**12.1 CHART F1 - GENERAL FLOW FOR PROCUREMENT**

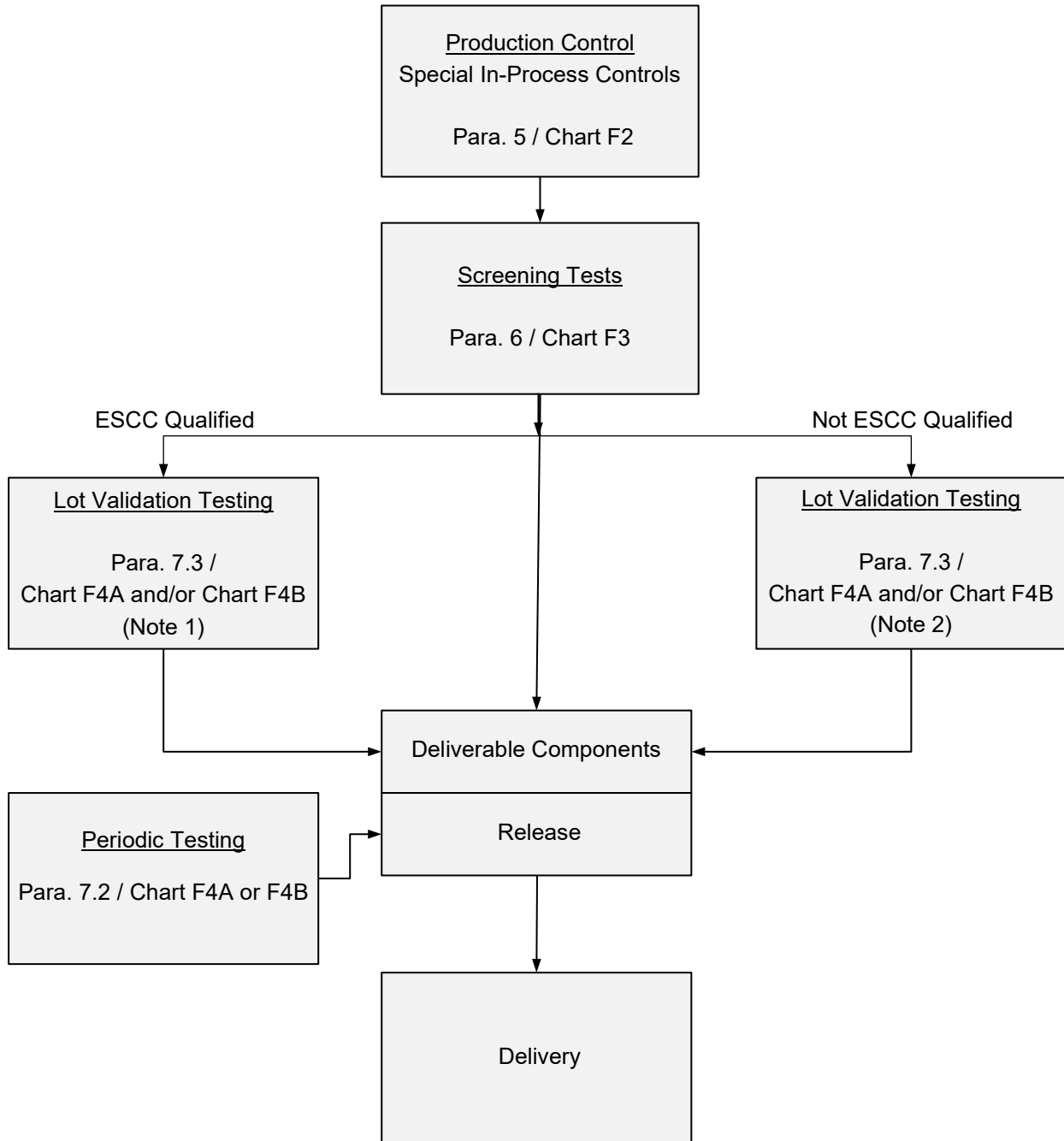

**NOTES:**

1. Lot Validation Testing is not required for qualified components unless specifically stipulated in the Purchase Order.
2. For unqualified components, the need for Lot Validation Testing shall be determined by the Orderer and the required testing shall be as stipulated in the Purchase Order (Ref. ESCC Basic Specification No. [23100](#)).



12.2 CHART F2 - PRODUCTION CONTROL (SPECIAL IN-PROCESS CONTROLS)

COMPONENT LOT MANUFACTURING	
SPECIAL IN-PROCESS CONTROLS	
Connector (and Contact) Lot (Pre-Assembly)	
Para. 8.2	Contact Capability (2)
Para. 8.3	Gold Plate Porosity (1) (2)
Para. 8.4	Plating Thickness (1) (2)
Para. 8.5	Magnetism Level (1) (3)
Para. 8.6	Pre-Assembly Visual Inspection and Dimension Check (4)
Cable Lot (Pre-Assembly)	
Para. 8.7	Insulation Flaws (Spark Test) (5)
Para. 8.8	Microsectioning of Strands (1) (2)
Para. 8.9	Anthony and Brown Test (1) (2) (6)
Para. 8.10	Coating Tests (1) (2)
Para. 8.11	Adhesion of Inner Conductor (1) (2)
Para. 8.12	Dielectric Strength of Jacket (1) (3)
Para. 8.13	Conductor Resistance (1) (2)
Para. 8.14	Capacitance (1) (2)
Para. 8.15	Characteristic Impedance (1) (2)
Para. 8.6	Pre-Assembly Visual Inspection and Dimension Check (4)
RF Cable Assemblies (During Assembly) (7)	
Para. 6.1	Serialisation
Para. 4.4	Marking
TO CHART F3 – SCREENING TESTS	

**NOTES:**

1. Testing is not required to be repeated for RF cable assemblies manufactured using ESCC qualified connectors and ESCC qualified cable.
2. Performed on a sample basis.
3. Only if specified in the RF cable assembly Detail Specification.
4. Dimension Check is not required to be repeated if performed as part of the Manufacturer's incoming inspection.
5. Performed by the cable Manufacturer on the cable core prior to application of the outer conductor and jacket.
6. Only if the cable lot is intended to be used to manufacture the RF cable assembly test vehicles used for Qualification Testing, Periodic Testing or Lot Validation Testing.
7. Qualified RF Cable Assemblies shall be assembled in accordance with the PID.

12.3 CHART F3 - SCREENING TESTS

<b>COMPONENTS FROM PRODUCTION CONTROL</b> (RF Cable Assemblies After Assembly)	
Para. 8.16	Length and Weight (1) (2)
Para. 8.17.1	Temperature Cycling
Para. 8.18	Coupling Proof Torque (1) (3) (4)
Para. 8.19.1	Mating and Unmating Forces (1) (3)
Para. 8.20.2	Room Temperature Electrical Measurements (1)
Para. 8.21	Multipaction (1) (5)
Para. 8.22	Radiographic Inspection (1)
Para. 8.23	RF Interface Gaging (1)
Para. 8.25	Shielding Effectiveness (6)
Para. 8.24	External Visual Inspection (1)
<b>TO CHART F4A OR F4B WHEN APPLICABLE</b>	

**NOTES:**

1. No failures are permitted.
2. Test may be performed at any point during Chart F3.
3. Performed on a sample basis.
4. Testing is not required to be repeated for RF cable assemblies manufactured using ESCC qualified connectors
5. Only if specified in the Detail Specification.
6. This test shall only be performed if specifically stipulated in the Purchase Order.

12.4 CHART F4 – QUALIFICATION, PERIODIC TESTING AND LOT VALIDATION TESTING

12.4.1 Chart F4A - Qualification Testing, Periodic Testing and Lot Validation Testing (Note 1)

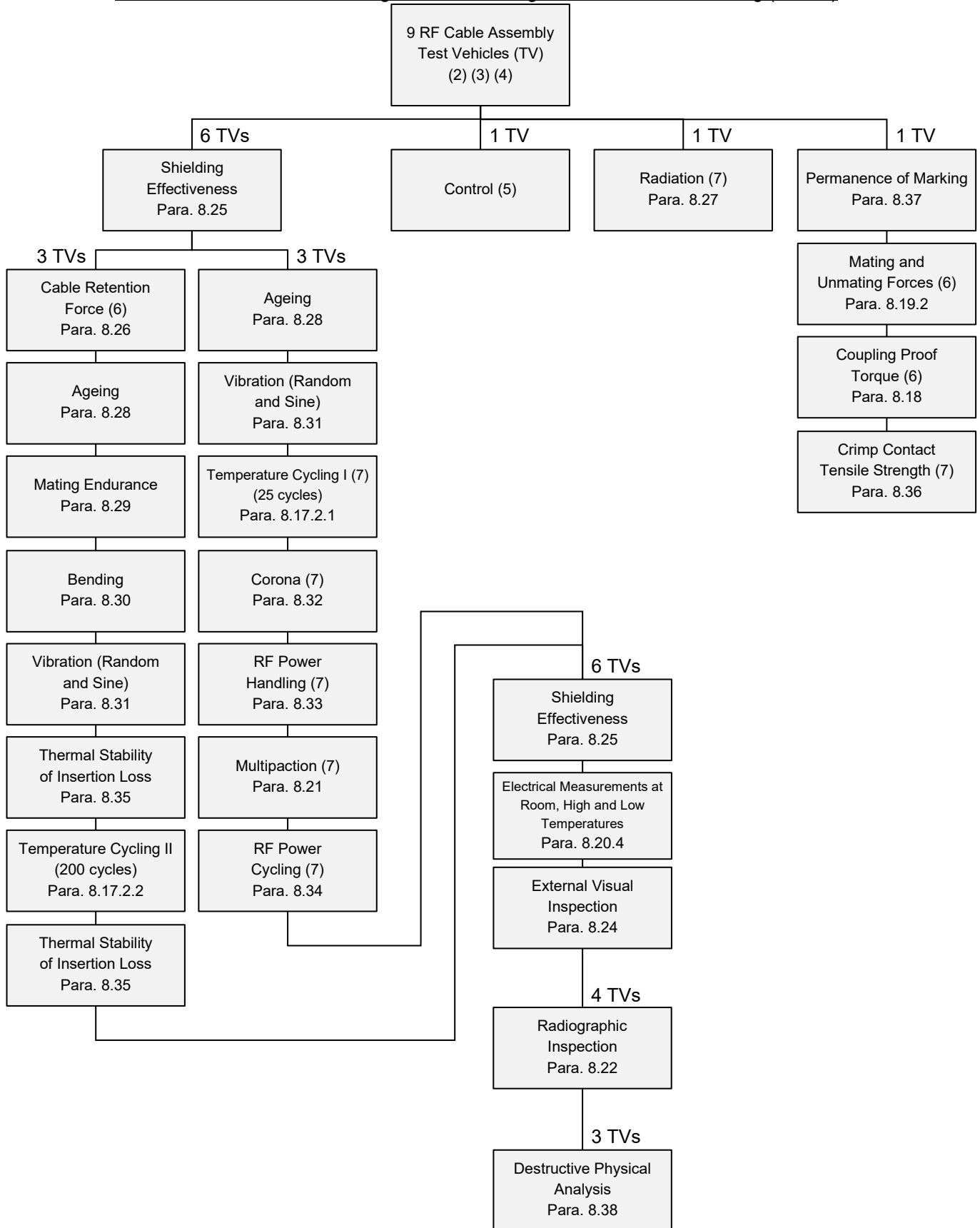

**NOTES:**

1. This chart applies for Qualification Testing (see Para. 7.1), for Periodic Testing for renewal of qualification after lapse (see Para. 7.2), and for Lot Validation Testing (see Para. 7.3).
2. The quantity of test vehicles (TV) to be subjected to each test or subgroup test sequence is indicated in Chart F4A.
3. For distribution, see Para. 7.1.2 for qualification and qualification maintenance, and Para. 7.3 for Lot Validation Testing.
4. No failures are permitted.
5. A control sample shall be used for reference purposes. Whenever electrical measurements are made on any component under test, the control sample shall also be measured.
6. Testing is not required to be repeated for RF cable assemblies manufactured using ESCC qualified connectors.
7. Only if specified in the Detail Specification.

12.4.2 Chart F4B - Periodic Testing and Lot Validation Testing (Note 1)

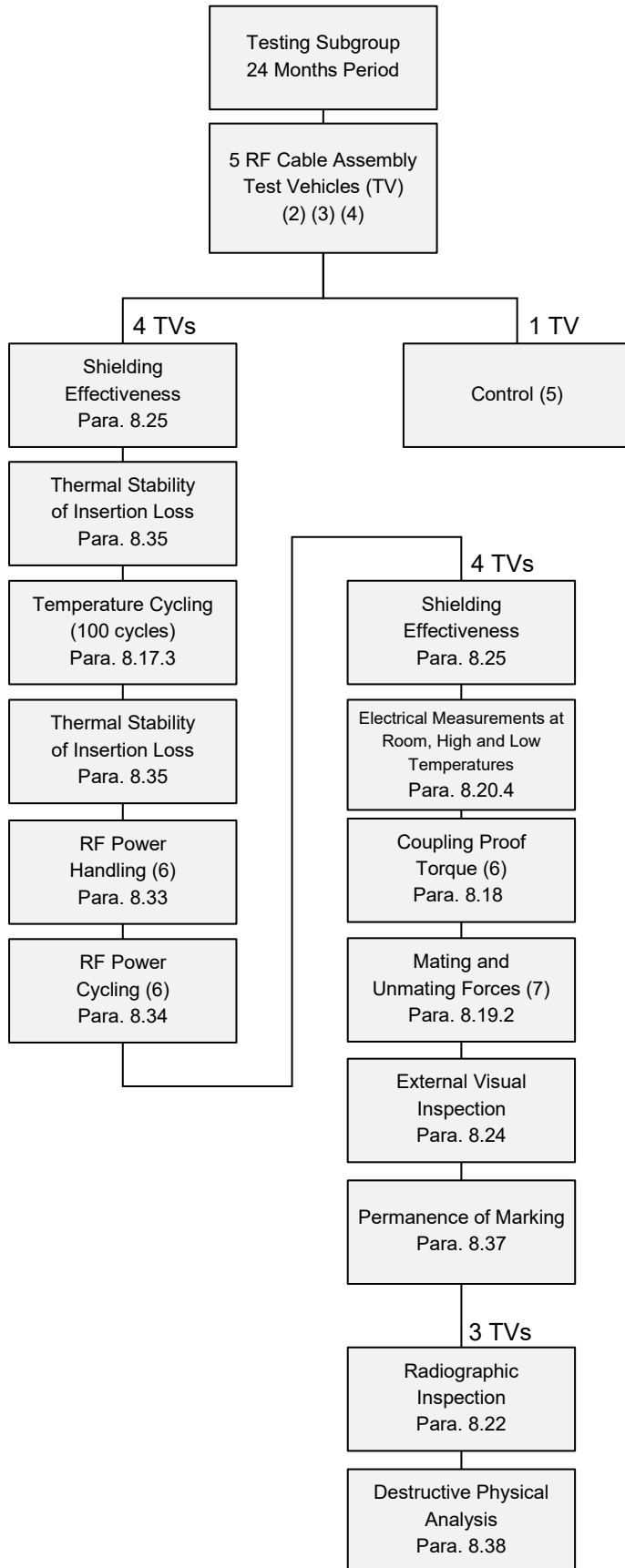

**NOTES:**

1. This chart applies for Periodic Testing for extension of qualification (see Para. 7.2), and for Lot Validation Testing (see Para. 7.3).
2. The quantity of test vehicles (TV) to be subjected to each test or subgroup test sequence is indicated in Chart F4B.
3. For distribution, see Para. 7.1.2 for qualification maintenance and Para. 7.3 for Lot Validation Testing.
4. No failures are permitted.
5. A control sample shall be used for reference purposes. Whenever electrical measurements are made on any component under test, the control sample shall also be measured.
6. Only if specified in the Detail Specification. Testing is not required to be performed on ESCC qualified components if there is no change in the material, process and design of the component since initial qualification, subject to technical justification being provided by the Manufacturer and agreed by the ESCC Executive.
7. Testing is not required to be repeated for RF cable assemblies manufactured using ESCC qualified connectors.