



**EXTRUDED, CROSS-LINKED MODIFIED ETFE  
INSULATED**

**WIRES AND CABLES ON SILVER-PLATED  
COPPER CONDUCTOR,**

**LIGHTWEIGHT, SPIRAL SHIELDED (WITH AND  
WITHOUT DRAIN WIRES),**

**LOW FREQUENCY, 600V, -100 TO +200°C**

**ESCC Detail Specification No. 3901/022**

Issue 5	March 2018
---------	------------



### **LEGAL DISCLAIMER AND COPYRIGHT**

European Space Agency, Copyright © 2018. All rights reserved.

The European Space Agency disclaims any liability or responsibility, to any person or entity, with respect to any loss or damage caused, or alleged to be caused, directly or indirectly by the use and application of this ESCC publication.

This publication, without prior permission of the European Space Agency and provided it is not used for a commercial purpose, may be:

- copied in whole, in any medium, without alteration or modification.
- copied in part, in any medium, provided that the ESCC document identification, comprising the ESCC symbol, document number and document issue, is removed.

**DOCUMENTATION CHANGE NOTICE**

(Refer to <https://escies.org> for ESCC DCR content)

DCR No.	CHANGE DESCRIPTION
1127	Specification upissued to incorporate editorial changes per DCR.

**TABLE OF CONTENTS**

1	GENERAL	6
1.1	SCOPE	6
1.2	TYPE VARIANTS	6
1.3	MAXIMUM RATINGS	6
1.4	PARAMETER DERATING INFORMATION	6
1.5	PHYSICAL CHARACTERISTICS	6
1.6	FUNCTIONAL DIAGRAM	6
2	APPLICABLE DOCUMENTS	14
3	TERMS, DEFINITIONS, ABBREVIATIONS, SYMBOLS AND UNITS	14
4	REQUIREMENTS	14
4.1	GENERAL	14
4.2	DEVIATIONS FROM GENERIC SPECIFICATION	14
4.2.1	Deviations from Special In-process Controls	14
4.2.2	Deviations from Final Production Tests (Chart II)	14
4.2.3	Deviations from Burn-in and Electrical Measurements (Chart III)	14
4.2.4	Deviations from Qualification Tests (Chart IV)	14
4.2.5	Deviations from Lot Acceptance Tests (Chart V)	14
4.3	MECHANICAL REQUIREMENTS	15
4.3.1	Dimension Check	15
4.3.2	Weight	15
4.4	MATERIALS AND FINISHES	16
4.4.1	Conductor	16
4.4.2	Insulation	16
4.4.3	Assembly	17
4.4.4	Shield	17
4.4.5	Drain Wire	17
4.4.6	Jacket	18
4.5	MARKING	18
4.5.1	General	18
4.5.2	The ESCC Component Number	18
4.5.3	Characteristics	18
4.5.4	Traceability Information	19
4.5.5	Additional Marking	19
4.6	ELECTRICAL MEASUREMENTS	20
4.6.1	Electrical Measurements at Room Temperature	20

4.6.2	Electrical Measurements at High and Low Temperatures	20
4.6.3	Circuits for Electrical Measurements	20
4.7	BURN-IN TESTS	20
4.8	ENVIRONMENTAL AND ENDURANCE TESTS	20
4.8.1	Mechanical Properties of Conductor	20
4.8.2	Accelerated Ageing	20
4.8.3	Wrap Test at Ambient Temperature	20
4.8.4	Voltage Test	20
4.8.5	Shrinkage	20
4.8.6	Blocking	21
4.8.7	Cold Bend Test	21
4.8.8	Cut-through Resistance	22
4.8.9	Notch Resistance	22
4.8.10	Flammability	22
4.8.11	Resistance to Fluids	22
4.8.12	Surface Resistance	22
4.8.13	Abrasion Resistance	22
4.8.14	Soldering	22
4.8.15	Solderability (Applicable to the shield only)	22
4.8.16	Radiation Resistance	22
4.8.17	Overload Resistance	22
4.8.18	Long-term Ageing Test	23
4.8.19	Anthony and Brown Test	23
	APPENDIX A	24

## 1 GENERAL

### 1.1 SCOPE

This specification details the ratings, physical and electrical characteristics, test and inspection data for Extruded Cross-linked Modified ETFE Insulated Wires and Cables, Lightweight, Spiral Shielded (With and Without Drain Wires), Low Frequency, 600V, -100 to +200 °C.

It shall be read in conjunction with ESCC Generic Specification No. [3901](#), the requirements of which are supplemented herein.

### 1.2 TYPE VARIANTS

Variants of the basic types of wires and cables specified herein, which are also covered by this specification, are listed in Table 1(a).

### 1.3 MAXIMUM RATINGS

The maximum ratings, applicable to the finished wires and cables specified herein, which shall not be exceeded at any time during use or storage in controlled space environment, are scheduled in Table 1(b).

### 1.4 PARAMETER DERATING INFORMATION

The derating information applicable to the finished wires and cables specified herein is as follows:

- The maximum current for each wire used in a bundle shall be:

$$I_{Bmax} = I_{max} \times \frac{29 - n}{28} \quad (\text{for } 1 < n < 15)$$
$$I_{Bmax} = \frac{I_{max}}{2} \quad (\text{for } n > 15)$$

where n = number of wires in the bundle.

- The temperature derating information is shown in Figure 1 with maximum current  $I_{max}$  for a single wire.
- The derating factors contained herein indicate maximum stress values and do not preclude further derating.

### 1.5 PHYSICAL CHARACTERISTICS

The physical characteristics of the finished wires and cables specified herein are shown in Figure 2.

### 1.6 FUNCTIONAL DIAGRAM

Not applicable.



**TABLE 1(a) – TYPE VARIANTS**

Variant No.	Shielded	Drain Wire	No. of Cores	Wire Size AWG	Stranding No. of Strands x Diameter (mm)	Conductor Characteristics			Shield Strand Ø (mm)	Core Max Ø (mm)	Finished Wire Or Cable Characteristics	
						Max Ø (mm)	Nom Section (mm <sup>2</sup> )	Max Ohmic Resistance (Ω/km)			Max Ø (mm)	Max Weight (kg/km)
01	X		1	-/(28)	7x0.12 (2)	0.38	0.08	248.9	0.08	0.63	1.22	3.56
02	X		1	001/(26)	19x0.1 (1) (2)	0.5	0.15	150	0.08	0.75	1.34	4.46
03	X		1	002/(24)	19x0.12 (1) (2)	0.62	0.21	106	0.08	0.87	1.46	5.6
04	X		1	004/(22)	19x0.15 (1)	0.76	0.34	58	0.08	1.01	1.61	7.49
05	X		1	006/(20)	19x0.2 (1)	1.01	0.6	32.3	0.08	1.26	1.86	10.51
06	X		1	010	19x0.25 (1)	1.26	0.93	20.3	0.08	1.56	2.14	15.47
07	X		2	-/(28)	7x0.12 (2)	0.38	0.08	256.4	0.08	0.63	1.8	6.04
08	X		2	001/(26)	19x0.1 (1) (2)	0.5	0.15	154.5	0.08	0.75	2.05	7.68
09	X		2	002/(24)	19x0.12 (1) (2)	0.62	0.21	109.2	0.08	0.87	2.3	9.56
10	X		2	004/(22)	19x0.15 (1)	0.76	0.34	59.8	0.08	1.01	2.58	13.55
11	X		2	006/(20)	19x0.2 (1)	1.01	0.6	33.3	0.08	1.26	3.1	20.18
12	X		2	010	19x0.25 (1)	1.26	0.93	20.9	0.1	1.56	3.69	30.37
13	X		3	-/(28)	7x0.12 (2)	0.38	0.08	256.4	0.08	0.63	1.96	9.05
14	X		3	001/(26)	19x0.1 (1) (2)	0.5	0.15	154.5	0.08	0.75	2.23	12.13
15	X		3	002/(24)	19x0.12 (1) (2)	0.62	0.21	109.2	0.08	0.87	2.51	15.24
16	X		3	004/(22)	19x0.15 (1)	0.76	0.34	59.8	0.08	1.01	2.82	20.56
17	X		3	006/(20)	19x0.2 (1)	1.01	0.6	33.3	0.1	1.26	3.39	30.4
18	X		3	010	19x0.25 (1)	1.26	0.93	20.9	0.1	1.56	4.01	43.87
19	X		4	-/(28)	7x0.12 (2)	0.38	0.08	256.4	0.08	0.63	2.64	12.99
20	X		4	001/(26)	19x0.1 (1) (2)	0.5	0.15	154.5	0.08	0.75	2.71	17.11
21	X		4	002/(24)	19x0.12 (1) (2)	0.62	0.21	109.2	0.08	0.87	3.17	21.11
22	X		4	004/(22)	19x0.15 (1)	0.76	0.34	59.8	0.08	1.01	3.75	28.35
23	X		4	006/(20)	19x0.2 (1)	1.01	0.6	33.3	0.1	1.26	4.38	41.47



Variant No.	Shielded	Drain Wire	No. of Cores	Wire Size AWG	Stranding No. of Strands x Diameter (mm)	Conductor Characteristics			Shield Strand Ø (mm)	Core Max Ø (mm)	Finished Wire Or Cable Characteristics	
						Max Ø (mm)	Nom Section (mm <sup>2</sup> )	Max Ohmic Resistance (Ω/km)			Max Ø (mm)	Max Weight (kg/km)
24	X		4	010	19x0.25 (1)	1.26	0.93	20.9	0.1	1.56	5.03	61.17
25	X		1	012/(16)	19x0.3 (1)	1.55	1.2	14.8	0.08	1.9	2.52	20.49
26	X		1	020	37x0.25 (1)	1.82	2	10.2	0.08	2.29	2.89	26.98
27	X		1	030/(12)	37x0.32 (1)	2.28	3	6.5	0.1	2.74	3.38	40.13
28	X		2	012/(16)	19x0.3 (1)	1.55	1.2	15.2	0.1	1.9	4.39	42.3
29	X		2	020	37x0.25 (1)	1.82	2	10.5	0.1	2.29	5.19	58.72
30	X		2	030/(12)	37x0.32 (1)	2.28	3	6.7	0.1	2.74	6.14	95.1
31	X		3	012/(16)	19x0.3 (1)	1.55	1.2	15.2	0.1	1.9	4.69	58.99
32	X		3	020	37x0.25 (1)	1.82	2	10.5	0.1	2.29	5.55	81.78
33	X		3	030/(12)	37x0.32 (1)	2.28	3	6.7	0.1	2.74	6.58	121.47
34	X		4	012/(16)	19x0.3 (1)	1.55	1.2	15.2	0.1	1.9	5.2	80.79
35	X		4	020	37x0.25 (1)	1.82	2	10.5	0.1	2.29	6.12	111.08
36	X		4	030/(12)	37x0.32 (1)	2.28	3	6.7	0.1	2.74	7.28	163.72
37	X	X	1	-/(28)	7x0.12 (2)	0.38	0.08	248.9	0.08	0.63	1.58	5.13
38	X	X	1	001/(26)	19x0.1 (1) (2)	0.5	0.15	150	0.08	0.75	1.82	7.02
39	X	X	1	002/(24)	19x0.12 (1) (2)	0.62	0.21	106	0.08	0.87	2.04	8.95
40	X	X	1	004/(22)	19x0.15 (1)	0.76	0.34	58	0.08	1.01	2.34	12.28
41	X	X	1	006/(20)	19x0.2 (1)	1.01	0.6	32.3	0.08	1.26	2.85	18.68
42	X	X	1	010	19x0.25 (1)	1.26	0.93	20.3	0.1	1.56	3.49	28.2
43	X	X	1	012/(16)	19x0.3 (2)	1.55	1.2	14.8	0.1	1.9	3.99	37.01
44	X	X	1	020	37x0.25 (1)	1.82	2	10.2	0.1	2.29	4.71	50.03
45	X	X	1	030/(12)	37x0.32 (1)	2.28	3	6.51	0.1	2.74	5.66	74.17
46	X	X	2	-/(28)	7x0.12 (2)	0.38	0.08	256.4	0.08	0.63	1.82	7.11
47	X	X	2	001/(26)	19x0.1 (1) (2)	0.5	0.15	154.5	0.08	0.75	2.06	9.8
48	X	X	2	002/(24)	19x0.12 (1) (2)	0.62	0.21	109.2	0.08	0.87	2.28	12.43





Variant No.	Shielded	Drain Wire	No. of Cores	Wire Size AWG	Stranding No. of Strands x Diameter (mm)	Conductor Characteristics			Shield Strand Ø (mm)	Core Max Ø (mm)	Finished Wire Or Cable Characteristics	
						Max Ø (mm)	Nom Section (mm <sup>2</sup> )	Max Ohmic Resistance (Ω/km)			Max Ø (mm)	Max Weight (kg/km)
49	X	X	2	004/(22)	19x0.15 (1)	0.76	0.34	59.8	0.08	1.01	2.58	17.06
50	X	X	2	006/(20)	19x0.2 (1)	1.01	0.6	33.3	0.08	1.26	3.07	26
51	X	X	2	010	19x0.25 (1)	1.26	0.93	20.9	0.1	1.56	3.78	39.68
52	X	X	2	012/(16)	19x0.3 (1)	1.55	1.2	15.2	0.1	1.9	4.26	52.08
53	X	X	2	020	37x0.25 (1)	1.82	2	10.5	0.1	2.29	5.19	71.87
54	X	X	2	030/(12)	37x0.32 (1)	2.28	3	6.7	0.1	2.74	6.14	106.84
55	X	X	3	-/(28)	7x0.12 (2)	0.38	0.08	256.4	0.08	0.63	1.92	8.6
56	X	X	3	001/(26)	19x0.1 (1) (2)	0.5	0.15	154.5	0.08	0.75	2.18	12.1
57	X	X	3	002/(24)	19x0.12 (1) (2)	0.62	0.21	109.2	0.08	0.87	2.42	15.57
58	X	X	3	004/(22)	19x0.15 (1)	0.76	0.34	59.8	0.08	1.01	2.74	21.64
59	X	X	3	006/(20)	19x0.2 (1)	1.01	0.6	33.3	0.1	1.26	3.32	34.79
60	X	X	3	010	19x0.25 (1)	1.26	0.93	20.9	0.1	1.56	4.03	51.1
61	X	X	3	012/(16)	19x0.3 (1)	1.55	1.2	15.2	0.1	1.9	4.55	67.53
62	X	X	3	020	37x0.25 (1)	1.82	2	10.5	0.1	2.29	5.55	93.52
63	X	X	3	030/(12)	37x0.32 (1)	2.28	3	6.7	0.1	2.74	6.58	139.79
64	X	X	4	-/(28)	7x0.12 (2)	0.38	0.08	256.4	0.08	0.63	2.2	10.73
65	X	X	4	001/(26)	19x0.1 (1) (2)	0.5	0.15	154.5	0.08	0.75	2.51	15.06
66	X	X	4	002/(24)	19x0.12 (1) (2)	0.62	0.21	109.2	0.08	0.87	2.8	19.48
67	X	X	4	004/(22)	19x0.15 (1)	0.76	0.34	59.8	0.08	1.01	3.18	27.06
68	X	X	4	006/(20)	19x0.2 (1)	1.01	0.6	33.3	0.1	1.26	3.87	43.37
69	X	X	4	010	19x0.25 (1)	1.26	0.93	20.9	0.1	1.56	4.73	64.16
70	X	X	4	012/(16)	19x0.3 (1)	1.55	1.2	15.2	0.1	1.9	5.36	84.93
71	X	X	4	020	37x0.25 (1)	1.82	2	10.5	0.1	2.29	6.31	116.63
72	X	X	4	030/(12)	37x0.32 (1)	2.28	3	6.7	0.1	2.74	7.8	176.93



**NOTES:**

1. In accordance with ISO 2635. AWG sizes are given for reference.
2. Copper alloy.

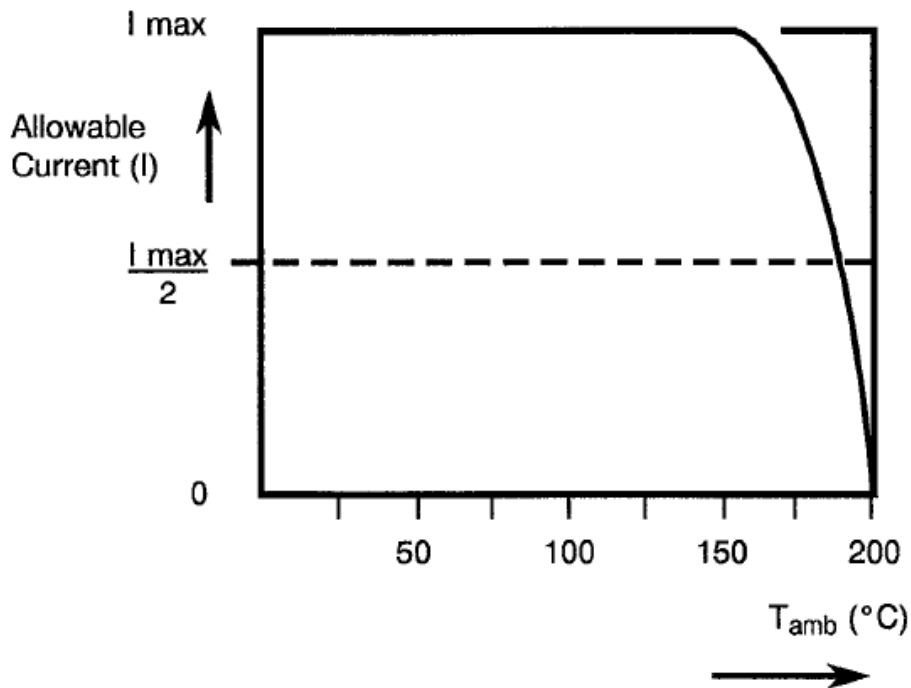
**TABLE 1(b) – MAXIMUM RATINGS**

No.	Characteristics	Symbol	Maximum Rating	Unit	Remarks
1	Voltage	$V_P$	600	$V_{rms}$	
2	Maximum Current (Note 1)	$I_{max}$	2 2.5 3.5 5 7.5 10 13 17 23	A	For nom. sect. (mm <sup>2</sup> ) / AWG: 0.08 / 28 0.15 / 26 0.21 / 24 0.34 / 22 0.6 / 20 0.93 1.2 / 16 2 3 / 12
3	Operating Temperature Range	$T_{amb}$	-100 to +200	°C	
4	Storage Temperature Range	$T_{stg}$	-100 to +200	°C	

**NOTES:**

- The above specified current will generate a temperature rise of approximately 50°C above ambient temperature in a vacuum environment. Precautions shall be taken to prevent the total temperature of the wire (ambient plus rise) exceeding the continuous operating temperature of the wire.

**FIGURE 1 – PARAMETER DERATING INFORMATION**



Allowable Current versus Temperature

**FIGURE 2 – PHYSICAL CHARACTERISTICS**

Dimensions are given in Table 1(a)

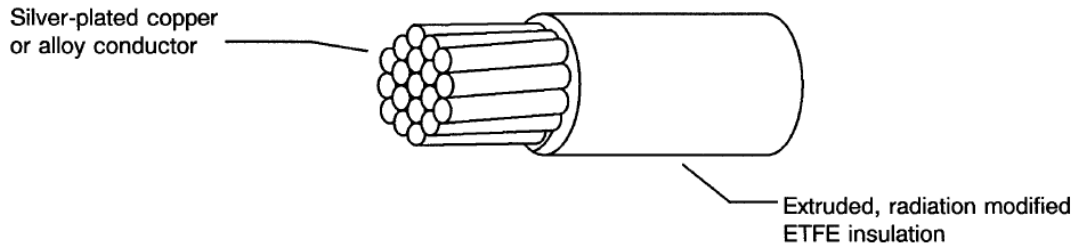
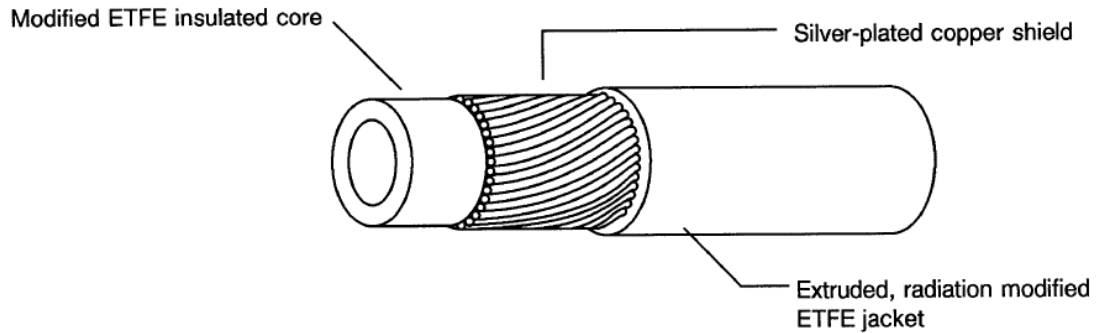
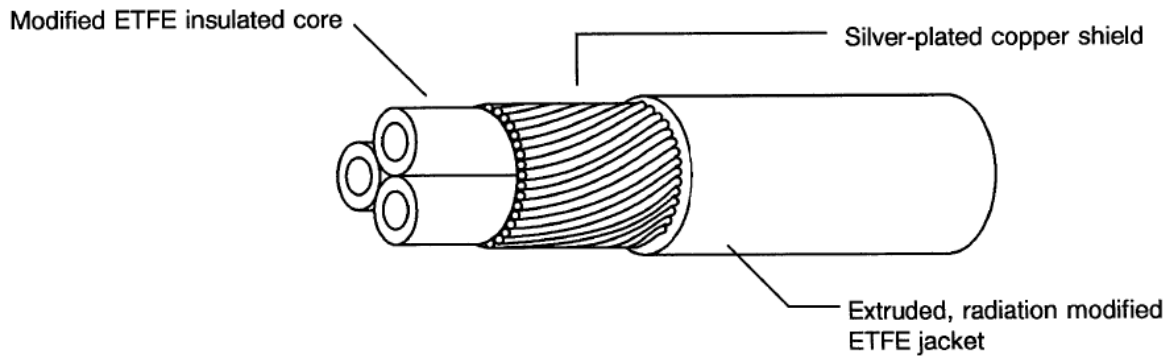
**FIGURE 2(a) – FINISHED WIRES****FIGURE 2(b) – SHIELDED AND JACKETED CABLES****FIGURE 2(c) – SHIELDED AND JACKETED CABLES**

FIGURE 2(d) – SHIELDED AND JACKETED CABLES WITH DRAIN WIRE

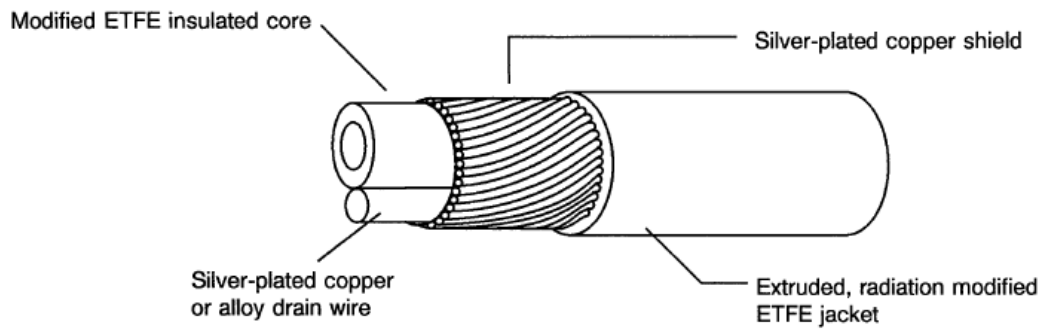
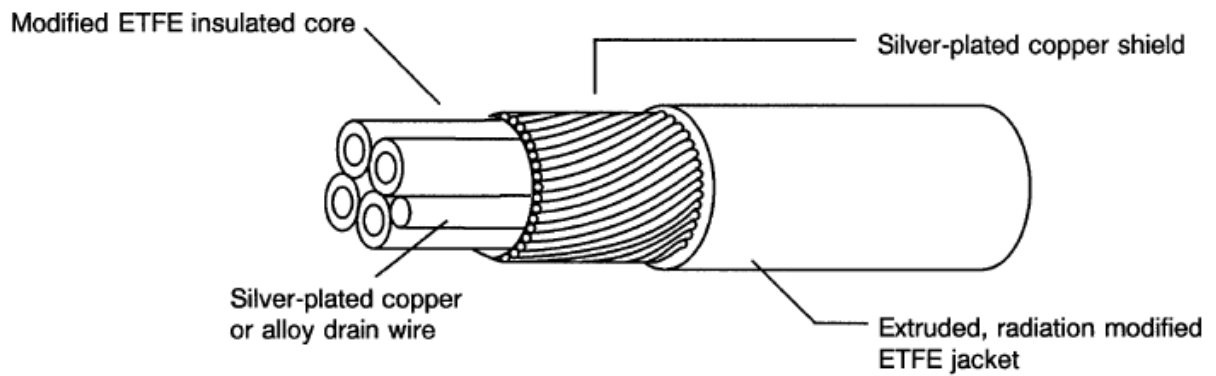


FIGURE 2(e) – SHIELDED AND JACKETED CABLES WITH DRAIN WIRE



## 2 **APPLICABLE DOCUMENTS**

The following documents form part of this specification and shall be read in conjunction with it:

- (a) ESCC Generic Specification No. [3901](#), Wires and Cables, Electrical, 600V, Low Frequency.
- (b) ASTM-B298-74, Silver-coated Soft or Annealed Copper Wires.
- (c) MIL-F-14256, Flux, Soldering, Liquid (Rosin Base).
- (d) ISO 2635, Conductors for General Purpose Aircraft Electrical Cables and Aerospace Applications - Dimensions and Characteristics.

## 3 **TERMS, DEFINITIONS, ABBREVIATIONS, SYMBOLS AND UNITS**

For the purpose of this specification, the terms, definitions, abbreviations, symbols and units specified in ESCC Basic Specification No. [21300](#) and ESCC Generic Specification No. [3901](#) shall apply.

## 4 **REQUIREMENTS**

### 4.1 **GENERAL**

The complete requirements for procurement of the finished wires and cables specified herein are stated in this specification and ESCC Generic Specification No. [3901](#). Deviations from the Generic Specification, applicable to this specification only, are listed in Para. 4.2.

Deviations from the applicable Generic Specification and this Detail Specification, formally agreed with specific Manufacturers on the basis that the alternative requirements are equivalent to the ESCC requirements and do not affect the components' reliability, are listed in the Appendices attached to this specification.

### 4.2 **DEVIATIONS FROM GENERIC SPECIFICATION**

#### 4.2.1 **Deviations from Special In-process Controls**

None.

#### 4.2.2 **Deviations from Final Production Tests (Chart II)**

None.

#### 4.2.3 **Deviations from Burn-in and Electrical Measurements (Chart III)**

Not applicable.

#### 4.2.4 **Deviations from Qualification Tests (Chart IV)**

None.

#### 4.2.5 **Deviations from Lot Acceptance Tests (Chart V)**

None.

4.3 MECHANICAL REQUIREMENTS

4.3.1 Dimension Check

The dimensions of the finished wires and cables specified herein shall be checked. They shall conform to those shown in Table 1(a), Figure 2 and Para 4.4 of this specification (see below for the list of parameters to be checked).

**LIST OF PARAMETERS TO BE CHECKED**

Parameter	Table 1(a)	Figure 2	Para. 4.4
<b><u>COMPOSITION</u></b>			
Number of conductors	X		
Gauge	X		
Shielding	X		
Jacket		X	
<b><u>CONDUCTOR</u></b>			
Nature			X
Outer diameter	X		
Number of strands	X		
Strand diameter	X		
Length of lay			X
Silver thickness			X
<b><u>INSULATION</u></b>			
Composition		X	X
Thickness			X
Concentricity			X
Outer diameter	X		
Core identification			X
Colour			X
<b><u>SHIELDING</u></b>			
Number of strands	X		
Type of shielding			X
Strand diameter	X		
Shield strand adhesion			X
Shielding lay			X
Shield coverage			X
<b><u>DRAIN WIRE</u></b>			
Nature		X	X
Outer diameter	X		
Number of strands	X		
Strand diameter	X		
Length of lay			X
Silver thickness			X
<b><u>JACKET</u></b>			
Composition		X	X
Thickness			X
Concentricity			X
Outer diameter	X		
Colour			X

4.3.2 Weight

The maximum weight of the finished wires and cables specified herein shall be as specified in Table 1(a).

#### 4.4 MATERIALS AND FINISHES

The materials and finishes shall be as specified herein. Where a definite material is not specified, a material which will enable the wires and cables specified herein to meet the performance requirements of this specification shall be used. Acceptance or approval of any constituent material does not guarantee acceptance of the finished product.

##### 4.4.1 Conductor

###### 4.4.1.1 *Material Characteristics*

All strands used in the manufacture of the conductors shall be silver-plated, high strength copper alloy for sizes 0.08 to 0.21mm<sup>2</sup> inclusive and silver-plated, soft or annealed, high conductivity copper for sizes 0.34 to 0.93mm<sup>2</sup> inclusive. The silver-coating on all strands shall be 2µm minimum.

On all copper conductors, any strand shall show a 10% minimum elongation at break and a 220N/mm<sup>2</sup> minimum tensile strength. On all high-strength alloy conductors, any strand shall show a 6% minimum elongation at break and a 350N/mm<sup>2</sup> minimum tensile strength.

The test shall be performed on single strands from the complete conductor, except for copper alloy, where the inner 7 strands shall be tested together to eliminate variance.

For determination of the conductor resistance at +20°C as mentioned in Para 9.5 of ESCC Generic Specification No. 3901, the  $\alpha$  coefficient for copper alloy is 0.0035.

###### 4.4.1.2 *Stranding*

The conductors shall be constructed of concentrically laid strands to produce a smooth and uniform conductor of circular cross-section and free from any high strands or other surface irregularities.

The length of the lay of the external layer shall not be less than 8, nor more than 16, times the maximum conductor diameter specified in Table 1(a).

###### 4.4.1.3 *Silver-coating Characteristics*

###### (a) Continuity

The silver-coating of the conductor strands shall be continuous. It shall not exhibit visible black spots after testing in accordance with the methods outlined in ASTM-B298-74. The test shall be performed on 3 specimens taken before applying the insulation.

###### (b) Adhesion

The silver-coating shall adhere firmly to the surface of the copper and not exhibit visible detachment when tested in accordance with ASTM-B298-74. This test shall be performed on 3 specimens taken before application of the insulation.

##### 4.4.2 Insulation

###### 4.4.2.1 *Material*

The insulating material shall be a flame-retarded radiation cross-linked ethylenetetrafluoroethylene copolymer with additives necessary for processing, performance and colour identification.

###### 4.4.2.2 *Construction*

The wire insulation shall consist of a single wall extrusion of polymer directly onto the conductor. The insulation shall have an even wall thickness and shall be concentric with the conductor, having a concentricity value (% ratio of minimum to maximum wall thickness) of 70% minimum.



#### 4.4.2.3 *Insulation Colour*

The insulation shall be extruded in a range of 11 colours as identified in Para. 4.5.3.

#### 4.4.3 *Assembly*

##### 4.4.3.1 *Construction*

A multicore cable shall be constructed by assembling the cores in a concentric lay. The length of lay shall not be less than 10, nor more than 16, times the maximum multicore assembly diameter as detailed in Table 1(a). The spiral shield shall have a right-hand lay.

#### 4.4.4 *Shield*

##### 4.4.4.1 *Material*

The shield shall be constructed from silver-coated, soft or annealed high-conductivity copper. Any strand shall show a 10% minimum elongation at break.

##### 4.4.4.2 *Construction*

The shield shall be closely, helically woven around the strands and shall provide not less than 92% coverage, 'K' being calculated by the following formula:

$$K = \frac{n \cdot d (L^2 + P^2)}{\sqrt{P \cdot L}}$$

where:

- K = % coverage,
- n = total number of shield strands,
- d = mean shield strand diameter,
- L = apparent shielding lay,
- P = outside perimeter of the shielded cable,

where:

- $P = \pi(D + d)$  for single core cable,
- $P = (D + d) + xD$  for multicore cable.

and where:

- D = mean diameter of core insulation,
- x = number of cores.

#### **N.B.**

The shield may exhibit an occasional gap between strands provided that:

- the coverage meets the required value.
- the gap width and gap length are no more than 0.5mm and 50mm respectively.

##### 4.4.4.3 *Silver-coating Characteristics*

The silver-coating characteristics of the shield wires shall conform to those of the conductor as specified in Para. 4.4.1.3.

#### 4.4.5 *Drain Wire*

Material, construction, stranding and size of the drain shall be exactly the same as the conductor of the insulated core or cores. It shall be positioned underneath the served, spiral wire shield.

#### 4.4.6 Jacket

The jacket material shall be an extruded flame-retarded radiation cross-linked ethylenetetrafluoroethylene copolymer with additives necessary for processing, performance and colour identification.

The jacket shall have an even wall thickness of 0.125mm minimum. The jacket shall be extruded in a range of 11 colours as identified in Para. 4.5.3.

### 4.5 MARKING

#### 4.5.1 General

The marking of all spools of finished wires and cables delivered to this specification shall be in accordance with the requirements of ESCC Basic Specification No. 21700. Each spool shall be marked in respect of:

- (a) The ESCC Component Number.
- (b) Characteristics.
- (c) Traceability Information.
- (d) Additional Marking.

#### 4.5.2 The ESCC Component Number

Each spool shall bear the ESCC Component Number which shall be constituted and marked as follows:

Example: 390102201B

- Detail Specification Number: 3901022
- Type Variant (see Table 1(a)): 01
- Testing Level (B is mandatory): B

#### 4.5.3 Characteristics

The characteristics shall show the length(s) of finished wire or cable wound on each spool and the colours used for conductor insulation and jacket. The length shall be marked as follows:

Example: 100m

- Length in metres (see Note): 100
- Symbol for metres: m

#### **NOTES:**

1. Whenever the length is less than 100 metres, insert a zero in the first block (example: 075m). If more than one length of finished wire or cable is wound on a spool, the characteristics of each length shall be marked as above.

The colours used for conductor insulation and jacket shall be codified and marked as follows:

Single Conductor (Variants 01 to 06, 25 to 27 and 37 to 45)

Codification	Description
x-y	y: Jacket Colour x: Conductor Insulation Colour

Two Conductors (Variants 07 to 12, 28 to 30 and 46 to 54)

Codification	Description
x/y-z	z: Jacket Colour x and y: Conductor Insulation Colours

Three Conductors (Variants 13 to 18, 31 to 33 and 55 to 63)

Codification	Description
x/y/z-a	a: Jacket Colour x, y and z: Conductor Insulation Colours

Four Conductors (Variants 19 to 24, 34 to 36 and 64 to 72)

Codification	Description
x/y/z/a-b	b: Jacket Colour x, y, z and a: Conductor Insulation Colours

The following numerical codes shall be used for conductor insulation and jacket colours:

0 = Black
1 = Brown
2 = Red
3 = Orange
4 = Yellow
5 = Green
6 = Blue
7 = Violet
8 = Grey
9 = White
2L = Pink

Example of conductor insulation and jacket colours marking: 0/2-9 (one conductor is black, the other conductor is red, and the jacket is white).

If no colour coding is specified, the wires and cables shall be delivered with white conductor insulation and jackets.

4.5.4 Traceability Information

Each spool shall be marked in respect of traceability information in accordance with the requirements of ESCC Basic Specification No. [21700](#).

4.5.5 Additional Marking

Each spool shall bear the cable Manufacturer's Quality Control Inspector's stamp.

4.6 ELECTRICAL MEASUREMENTS

4.6.1 Electrical Measurements at Room Temperature

The parameters to be measured at room temperature are scheduled in Table 2. The measurements shall be performed at  $T_{amb} = +22 \pm 3$  °C.

4.6.2 Electrical Measurements at High and Low Temperatures

Not applicable.

4.6.3 Circuits for Electrical Measurements

Not applicable.

4.7 BURN-IN TESTS

Not applicable.

4.8 ENVIRONMENTAL AND ENDURANCE TESTS

4.8.1 Mechanical Properties of Conductor

As detailed in Paras. 4.4.1.1, 4.4.4 and 4.4.5 of this Specification.

4.8.2 Accelerated Ageing

Ageing Temperature:  $+230 \pm 5$  °C.

The mandrel diameter and appropriate weight used for accelerated age testing of the finished wires are given in Table A. For shielded cables, a change in the shield's aspect shall not be cause for rejection.

**TABLE A – MANDREL DIAMETERS AND LOADS FOR FINISHED WIRES**

Wire Size (mm <sup>2</sup> )	Mandrel Diameter (mm)	Weight (kg)
0.08	6.5	0.06
0.15	10	0.06
0.21	10	0.115
0.34	13	0.17
0.6	13	0.23
0.93	13	0.23
1.2	20	0.34
2	25	0.45
3	38	0.68

4.8.3 Wrap Test at Ambient Temperature

The mandrel diameters and applied loads for wrap testing of finished wires are given in Table A. The mandrel diameters and applied loads for screened and jacketed cables are given in Table B.

4.8.4 Voltage Test

No particular conditions are applicable.

4.8.5 Shrinkage

The shrinkage temperature shall be  $+200 \pm 5$  °C.

4.8.6 Blocking

The blocking temperature shall be  $+200 \pm 5$  °C.

4.8.7 Cold Bend Test

The mandrel diameters and loads shall be as specified in Table C.

**TABLE B – MANDREL DIAMETERS AND LOADS FOR SHIELDED AND JACKETED CABLES**

Cable Size (mm <sup>2</sup> )	Number of Cores	Mandrel Diameter (mm)	Load (kg)
0.08	1	19	0.06
	2	25	0.12
	3	25	0.18
	4	25	0.24
0.15	1	19	0.06
	2	25	0.12
	3	25	0.18
	4	32	0.24
0.21	1	19	0.12
	2	25	0.23
	3	25	0.35
	4	32	0.4
0.34	1	19	0.17
	2	32	0.34
	3	32	0.51
	4	44	0.68
0.6	1	25	0.23
	2	32	0.46
	3	44	0.69
	4	44	0.92
0.93	1	25	0.23
	2	44	0.46
	3	44	0.69
	4	57	0.92
1.2	1	25	0.34
	2	44	0.68
	3	44	1.02
	4	57	1.36
2	1	32	0.45
	2	57	0.68
	3	57	1.35
	4	57	1.8
3	1	32	0.68
	2	57	1.36
	3	76	2.04
	4	76	2.72

**TABLE C – MANDREL DIAMETERS AND LOADS FOR FINISHED WIRES OR CORES**

Wire Size (mm <sup>2</sup> )	Mandrel Diameter (mm)	Weight (kg)
0.08	10	0.23
0.15	12.5	0.23
0.21	12.5	0.45
0.34	20	0.45
0.6	20	0.45
0.93	25.4	0.45
1.2	25.4	0.45
2	38.1	1.3
3	50.8	1.36

4.8.8 Cut-through Resistance

The mean load measured during the required tests shall not be less than the relevant value specified below:

Wire Size (mm <sup>2</sup> )	0.08	0.15	0.21	0.34	0.6	0.93	1.2	2	3
Cut-through Load (kg)	1.5	2	2.5	3.5	4.5	5.5	6.5	7	7.5

4.8.9 Notch Resistance

The depth of notch shall be one third of the nominal wall thickness.

4.8.10 Flammability

No particular conditions are applicable.

4.8.11 Resistance to Fluids

No particular conditions are applicable.

4.8.12 Surface Resistance

No particular conditions are applicable.

4.8.13 Abrasion Resistance

The weight to be applied to the needle is specified below:

Wire Size (mm <sup>2</sup> )	0.08	0.15	0.21	0.34	0.6	0.93	1.2	2	3
Scrape Abrasion (kg)	0.2	0.3	0.3	0.4	0.4	0.5	0.6	0.9	0.9

4.8.14 Soldering

No particular conditions are applicable.

4.8.15 Solderability (Applicable to the shield only)

RMA type flux according to MIL-F-14256 shall be used.

4.8.16 Radiation Resistance

No particular conditions are applicable.

4.8.17 Overload Resistance

No particular conditions are applicable.

**4.8.18 Long-term Ageing Test**

The long-term ageing temperature shall be +200°C. For shielded cables, a change in the shield's aspect shall not be cause of rejection.

**4.8.19 Anthony and Brown Test**

No particular conditions are applicable.

**TABLE 2 – ELECTRICAL MEASUREMENTS AT ROOM TEMPERATURE**

No.	Characteristics	Specification and Test Method	Test Condition	Limits	Unit
1	Conductor Resistance	ESCC No. 3901, Section 9	Para. 9.5	Table 1(a)	Ω/km
2	Spark Test	ESCC No. 3901, Section 9	Para. 9.6	Insulation: 3 Jacket: 1.5	kV
3	Voltage Test	ESCC No. 3901, Section 9	Para. 9.7	Para. 9.7	kV
4	Insulation Resistance	ESCC No. 3901, Section 9	Para. 9.8	Insulation: 750 Jacket: 300	MΩ.km
5	Surface Resistance	ESCC No. 3901, Section 9	Para. 9.22	125	MΩ.mm

**APPENDIX A**

**AGREED DEVIATIONS FOR TYCO ELECTRONICS (UK) LTD. (GB)**

Items Affected	Description of Deviations
Para. 4.2.1	<p>The silver-coating thickness on soft annealed copper may be determined by electron microscopy and electromechanical mass removal calculation (Kocur technique). The electron microscope shall have a magnification greater than x600 and enable measurement of the minimal radial-thickness of a single strand.</p> <p><b><u>N.B.</u></b> The criteria specified in ESCC Generic Specification No. <a href="#">3901</a> Para. 5.3.2 remain unchanged.</p>
Para. 4.2.2	<p>"Stripping Capability" may be performed using the test methods specified below.</p> <p>The stripping of the wire insulation shall be conducted using a mechanical wire stripper with preset precision die blades designed for wires conforming to MIL-W-22759. The following procedure shall be used to assess the wire's strippability:</p> <ul style="list-style-type: none"> <li>(a) The appropriate set of die blades are selected and correctly positioned in the hand held tool.</li> <li>(b) The wire is positioned on the appropriately sized die and 25mm of the insulation is stripped.</li> </ul> <p>The insulation must strip on the first application of the hand tool without difficulty.</p> <p>Stripping of the cable jacket shall be conducted with a hand held tool to make a shallow notch in the jacket at a distance of 50mm from the cable end. The cable is then gently flexed to propagate the notch through the jacket wall and the excess jacket material is then removed by hand with a firm pulling and twisting action.</p> <p>Alternatively, thermal strippers can be used for both the wire insulation and the cable jacket. In keeping with industrial hygiene practices, avoid inhalation of smoke or fumes arising from the thermal strippers.</p> <p><b><u>N.B.</u></b> The criteria specified in ESCC Generic Specification No. <a href="#">3901</a> Para. 9.9 remain unchanged.</p>
Paras. 4.2.4 and 4.2.5	<p>Para. 9.18, Cut-through Resistance: The load may be applied directly to the needle, in which case the rate of loading shall be 6kg/minute.</p>