



**DIODES, MICROWAVE, SILICON, HYPER-ABRUPT JUNCTION
TUNING VARACTOR**

BASED ON TYPES DH76XXX AND EH76XXX

ESCC Detail Specification No. 5512/023

Issue 7	March 2023
---------	------------



LEGAL DISCLAIMER AND COPYRIGHT

European Space Agency, Copyright © 2023. All rights reserved.

The European Space Agency disclaims any liability or responsibility, to any person or entity, with respect to any loss or damage caused, or alleged to be caused, directly or indirectly by the use and application of this ESCC publication.

This publication, without the prior permission of the European Space Agency and provided that it is not used for a commercial purpose, may be:

- copied in whole, in any medium, without alteration or modification.
- copied in part, in any medium, provided that the ESCC document identification, comprising the ESCC symbol, document number and document issue, is removed.

DOCUMENTATION CHANGE NOTICE

(Refer to <https://escies.org> for ESCC DCR content)

DCR No.	CHANGE DESCRIPTION
1553	Specification upissued to incorporate changes per DCR.

TABLE OF CONTENTS

1	GENERAL	6
1.1	SCOPE	6
1.2	APPLICABLE DOCUMENTS	6
1.3	TERMS, DEFINITIONS, ABBREVIATIONS, SYMBOLS AND UNITS	6
1.4	THE ESCC COMPONENT NUMBER AND COMPONENT TYPE VARIANTS	6
1.4.1	The ESCC Component Number	6
1.4.2	Component Type Variants	6
1.5	MAXIMUM RATINGS	9
1.6	HANDLING PRECAUTIONS	9
1.7	PHYSICAL DIMENSIONS AND TERMINAL IDENTIFICATION	10
1.7.1	Ceramic Pill A (2 Leads) - Variants 01, 10, 19, 28, 37, 46, 55, 64	10
1.7.2	Ceramic Pill B - Variants 02, 11, 20, 29, 38, 47, 56, 65	11
1.7.3	Ceramic Pill C (Cathode Lead) - Variants 03, 12, 21, 30, 39, 48, 57, 66	12
1.7.4	Ceramic Pill D (Anode Lead) - Variants 04, 13, 22, 31, 40, 49, 58, 67	13
1.7.5	Ceramic Pill E (2 Leads) - Variants 05, 14, 23, 32, 41, 50, 59, 68	14
1.7.6	Ceramic Pill F (Anode Lead) - Variants 06, 15, 24, 33, 42, 51, 60, 69	15
1.7.7	Ceramic Pill G - Variants 07, 16, 25, 34, 43, 52, 61, 70	16
1.7.8	Die - Variants 73 to 80	17
1.8	FUNCTIONAL DIAGRAM	17
1.9	MATERIALS AND FINISHES	18
1.9.1	Materials and Finishes of Packaged Components	18
1.9.2	Materials and Finishes of Die Components	18
2	REQUIREMENTS	18
2.1	GENERAL	18
2.1.1	Deviations from the Generic Specification	18
2.1.1.1	Deviations from Qualification and Periodic Tests – Chart F4	18
2.2	MARKING	18
2.3	DIE SHEAR	18
2.4	TERMINAL STRENGTH	19
2.5	ELECTRICAL MEASUREMENTS AT ROOM, HIGH AND LOW TEMPERATURES	19
2.5.1	Room Temperature Electrical Measurements	19
2.5.2	High and Low Temperatures Electrical Measurements	20
2.6	PARAMETER DRIFT VALUES	20
2.7	INTERMEDIATE AND END-POINT ELECTRICAL MEASUREMENTS	21
2.8	BURN-IN 1 CONDITIONS	21
2.9	BURN-IN 2 CONDITIONS	21



2.10 OPERATING LIFE CONDITIONS

21

APPENDIX 'A'

22

1 GENERAL

1.1 SCOPE

This specification details the ratings, physical and electrical characteristics and test and inspection data for the component type variants and/or the range of components specified below. It supplements the requirements of, and shall be read in conjunction with, the ESCC Generic Specification listed under Applicable Documents.

1.2 APPLICABLE DOCUMENTS

The following documents form part of this specification and shall be read in conjunction with it:

- (a) ESCC Generic Specification No. **5010**
- (b) **MIL-STD-750**, Test Methods and Procedures for Semiconductor Devices

1.3 TERMS, DEFINITIONS, ABBREVIATIONS, SYMBOLS AND UNITS

For the purpose of this specification, the terms, definitions, abbreviations, symbols and units specified in ESCC Basic Specification No. **21300** shall apply.

1.4 THE ESCC COMPONENT NUMBER AND COMPONENT TYPE VARIANTS

1.4.1 The ESCC Component Number

The ESCC Component Number shall be constituted as follows:

Example: 551202301

- Detail Specification Reference: 5512023
- Component Type Variant Number: 01 (as required)

1.4.2 Component Type Variants

The component type variants applicable to this specification are as follows:

Packaged Components

Variant Number	Based On Type	Package Type / Description	Total Capacitance C_T (pF)		Tuning Ratio C_{T1}/C_{T12}		Lead/Terminal Material and Finish (Note 1)		Weight Max (g)
			Min	Max	Min	Max	Anode	Cathode	
01	DH76010	Ceramic Pill A (2 Leads)	0.9	1.34	3.8	5.1	E2	E2	0.02
02	DH76010	Ceramic Pill B	0.9	1.34	3.8	5.1	D7	D7	0.02
03	DH76010	Ceramic Pill C (Cathode Lead)	0.9	1.34	3.8	5.1	D7	E2	0.02
04	DH76010	Ceramic Pill D (Anode Lead)	0.9	1.34	3.8	5.1	E2	D7	0.02
05	DH76010	Ceramic Pill E (2 Leads)	0.9	1.34	3.8	5.1	E2	E2	0.02
06	DH76010	Ceramic Pill F (Anode Lead)	0.9	1.34	3.8	5.1	E2	D7	0.02
07	DH76010	Ceramic Pill G	0.94	1.42	3.5	4.7	D7	A7	0.15
10	DH76015	Ceramic Pill A (2 Leads)	1.3	1.94	4.1	5.5	E2	E2	0.02
11	DH76015	Ceramic Pill B	1.3	1.94	4.1	5.5	D7	D7	0.02
12	DH76015	Ceramic Pill C (Cathode Lead)	1.3	1.94	4.1	5.5	D7	E2	0.02
13	DH76015	Ceramic Pill D (Anode Lead)	1.3	1.94	4.1	5.5	E2	D7	0.02

Variant Number	Based On Type	Package Type / Description	Total Capacitance C_T (pF)		Tuning Ratio C_{T1}/C_{T12}		Lead/Terminal Material and Finish (Note 1)		Weight Max (g)
			Min	Max	Min	Max	Anode	Cathode	
14	DH76015	Ceramic Pill E (2 Leads)	1.3	1.94	4.1	5.5	E2	E2	0.02
15	DH76015	Ceramic Pill F (Anode Lead)	1.3	1.94	4.1	5.5	E2	D7	0.02
16	DH76015	Ceramic Pill G	1.34	2.02	3.9	5.2	D7	A7	0.15
19	DH76022	Ceramic Pill A (2 Leads)	1.86	2.78	4.3	5.7	E2	E2	0.02
20	DH76022	Ceramic Pill B	1.86	2.78	4.3	5.7	D7	D7	0.02
21	DH76022	Ceramic Pill C (Cathode Lead)	1.86	2.78	4.3	5.7	D7	E2	0.02
22	DH76022	Ceramic Pill D (Anode Lead)	1.86	2.78	4.3	5.7	E2	D7	0.02
23	DH76022	Ceramic Pill E (2 Leads)	1.86	2.78	4.3	5.7	E2	E2	0.02
24	DH76022	Ceramic Pill F (Anode Lead)	1.86	2.78	4.3	5.7	E2	D7	0.02
25	DH76022	Ceramic Pill G	1.9	2.86	4.1	5.5	D7	A7	0.15
28	DH76033	Ceramic Pill A (2 Leads)	2.74	4.1	4.5	6	E2	E2	0.02
29	DH76033	Ceramic Pill B	2.74	4.1	4.5	6	D7	D7	0.02
30	DH76033	Ceramic Pill C (Cathode Lead)	2.74	4.1	4.5	6	D7	E2	0.02
31	DH76033	Ceramic Pill D (Anode Lead)	2.74	4.1	4.5	6	E2	D7	0.02
32	DH76033	Ceramic Pill E (2 Leads)	2.74	4.1	4.5	6	E2	E2	0.02
33	DH76033	Ceramic Pill F (Anode Lead)	2.74	4.1	4.5	6	E2	D7	0.02
34	DH76033	Ceramic Pill G	2.74	4.18	4.3	5.8	D7	A7	0.15
37	DH76047	Ceramic Pill A (2 Leads)	3.86	5.78	4.6	6.1	E2	E2	0.02
38	DH76047	Ceramic Pill B	3.86	5.78	4.6	6.1	D7	D7	0.02
39	DH76047	Ceramic Pill C (Cathode Lead)	3.86	5.78	4.6	6.1	D7	E2	0.02
40	DH76047	Ceramic Pill D (Anode Lead)	3.86	5.78	4.6	6.1	E2	D7	0.02
41	DH76047	Ceramic Pill E (2 Leads)	3.86	5.78	4.6	6.1	E2	E2	0.02
42	DH76047	Ceramic Pill F (Anode Lead)	3.86	5.78	4.6	6.1	E2	D7	0.02
43	DH76047	Ceramic Pill G	3.9	5.86	4.5	6	D7	A7	0.15
46	DH76068	Ceramic Pill A (2 Leads)	5.54	8.3	4.6	6.2	E2	E2	0.02
47	DH76068	Ceramic Pill B	5.54	8.3	4.6	6.2	D7	D7	0.02
48	DH76068	Ceramic Pill C (Cathode Lead)	5.54	8.3	4.6	6.2	D7	E2	0.02
49	DH76068	Ceramic Pill D (Anode Lead)	5.54	8.3	4.6	6.2	E2	D7	0.02
50	DH76068	Ceramic Pill E (2 Leads)	5.54	8.3	4.6	6.2	E2	E2	0.02
51	DH76068	Ceramic Pill F (Anode Lead)	5.54	8.3	4.6	6.2	E2	D7	0.02
52	DH76068	Ceramic Pill G	5.58	8.38	4.6	6.1	D7	A7	0.15
55	DH76100	Ceramic Pill A (2 Leads)	8.1	12.14	4.7	6.3	E2	E2	0.02
56	DH76100	Ceramic Pill B	8.1	12.14	4.7	6.3	D7	D7	0.02
57	DH76100	Ceramic Pill C (Cathode Lead)	8.1	12.14	4.7	6.3	D7	E2	0.02
58	DH76100	Ceramic Pill D (Anode Lead)	8.1	12.14	4.7	6.3	E2	D7	0.02

Variant Number	Based On Type	Package Type / Description	Total Capacitance C_T (pF)		Tuning Ratio C_{T1}/C_{T12}		Lead/Terminal Material and Finish (Note 1)		Weight Max (g)
			Min	Max	Min	Max	Anode	Cathode	
59	DH76100	Ceramic Pill E (2 Leads)	8.1	12.14	4.7	6.3	E2	E2	0.02
60	DH76100	Ceramic Pill F (Anode Lead)	8.1	12.14	4.7	6.3	E2	D7	0.02
61	DH76100	Ceramic Pill G	8.14	12.22	4.2	6.2	D7	A7	0.15
64	DH76150	Ceramic Pill A (2 Leads)	12.1	18.14	4.7	6.3	E2	E2	0.02
65	DH76150	Ceramic Pill B	12.1	18.14	4.7	6.3	D7	D7	0.02
66	DH76150	Ceramic Pill C (Cathode Lead)	12.1	18.14	4.7	6.3	D7	E2	0.02
67	DH76150	Ceramic Pill D (Anode Lead)	12.1	18.14	4.7	6.3	E2	D7	0.02
68	DH76150	Ceramic Pill E (2 Leads)	12.1	18.14	4.7	6.3	E2	E2	0.02
69	DH76150	Ceramic Pill F (Anode Lead)	12.1	18.14	4.7	6.3	E2	D7	0.02
70	DH76150	Ceramic Pill G	12.1	18.22	4.7	6.3	D7	A7	0.15

Die Components (Note 2)

Variant Number	Based On Type	Junction Capacitance C_J (pF)		Tuning Ratio C_{J1}/C_{J12}		Total Capacitance C_T (pF) (Note 3)		Tuning Ratio C_{T1}/C_{T12} (Note 3)	
		Min	Max	Min	Max	Min	Max	Min	Max
73	EH76010	0.8	1.2	4.6	6.1	0.94	1.42	3.5	4.7
74	EH76015	1.2	1.8	4.7	6.3	1.34	2.02	3.9	5.2
75	EH76022	1.76	2.64	4.7	6.3	1.9	2.86	4.1	5.5
76	EH76033	2.64	3.96	4.8	6.4	2.74	4.18	4.3	5.8
77	EH76047	3.76	5.64	4.8	6.4	3.9	5.86	4.5	6
78	EH76068	5.44	8.16	4.8	6.4	5.58	8.38	4.6	6.1
79	EH76100	8	12	4.8	6.4	8.14	12.22	4.2	6.2
80	EH76150	12	18	4.8	6.4	12.1	18.22	4.7	6.3

NOTES:

1. The lead/terminal material and finish shall be in accordance with the requirements of ESCC Basic Specification No. [23500](#).
2. For Die Components, Variants 73 to 80, the default package selected for assembly of the Packaged Test Sublot shall be Ceramic Pill G. At the Manufacturer's option, any of the other packages specified herein with a Variant for the same die may be selected. The die applicable to each Variant is indicated by the based on type number.
3. In cases where the default package is not selected for the Packaged Test Sublot, the Total Capacitance and Tuning Ratio limits of the selected package shall apply.

1.5 MAXIMUM RATINGS

The maximum ratings shall not be exceeded at any time during use or storage.

Maximum ratings shall only be exceeded during testing to the extent specified in this specification and when stipulated in Test Methods and Procedures of the ESCC Generic Specification.

Characteristics	Symbols	Maximum Ratings	Unit	Remarks
Reverse Voltage	V_{Rmax}	-20	V	$I_R = 10\mu A$ Note 1
Operating Temperature Range	T_{op}	-55 to +150	°C	T_{amb}
Storage Temperature Range	T_{stg}	-65 to +175	°C	
Soldering Temperature	T_{sol}	+230	°C	Note 2

NOTES:

1. At $T_{amb} \leq +25^\circ C$. For $T_{amb} > +25^\circ C$, derate linearly to -16V at $T_{amb} = +150^\circ C$.
2. Duration 5 seconds maximum and the same terminal shall not be resoldered until 3 minutes have elapsed. Only applicable to Variants 01 to 07, 10 to 16, 19 to 25, 28 to 34, 37 to 43, 46 to 52, 55 to 61 and 64 to 70 (Packaged Components).

1.6 HANDLING PRECAUTIONS

These devices are susceptible to damage by electrostatic discharge. Therefore, suitable precautions shall be employed for protection during all phases of manufacture, testing, packaging, shipment and any handling.

Variants 01 to 07, 10 to 16, 19 to 25, 28 to 34, 37 to 43, 55 to 61, 64 to 70, 73 to 77, 79 and 80 are categorised as Class 2 per ESCC Basic Specification No. [23800](#) with a Minimum Critical Path Failure Voltage of 2500V.

Variants 46 to 52 and 78 are categorised as Class 3 per ESCC Basic Specification No. [23800](#) with a Minimum Critical Path Failure Voltage of 5000V.

1.7 PHYSICAL DIMENSIONS AND TERMINAL IDENTIFICATION

1.7.1 Ceramic Pill A (2 Leads) - Variants 01, 10, 19, 28, 37, 46, 55, 64

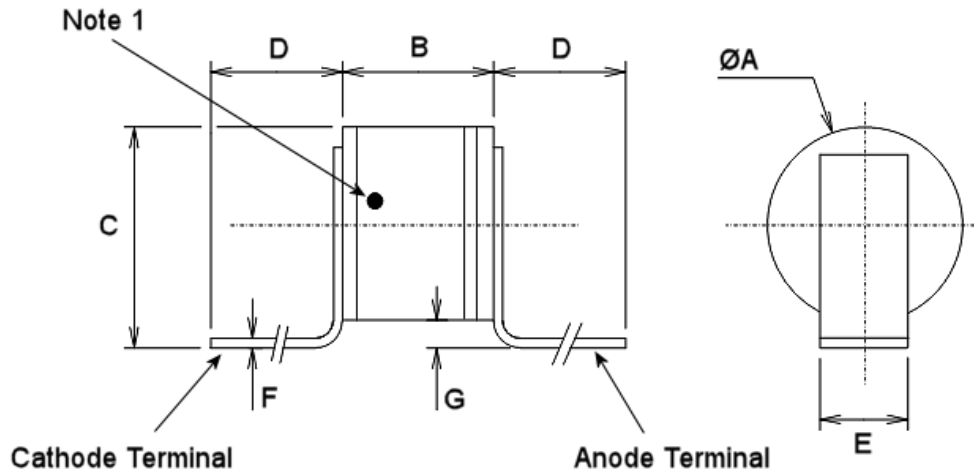

Symbols	Dimensions mm		Remarks
	Min	Max	
ØA	1.07	1.47	
B	0.95	1.35	
C	1.3	1.9	Both terminals
D	2.5	-	
E	0.55	0.65	Both terminals
F	0.06	0.1	Both terminals
G	0.1	0.5	Both terminals

NOTES:

- Terminal identification: The body shall be marked at a suitable location near the cathode terminal with a black dot.

1.7.2 Ceramic Pill B - Variants 02, 11, 20, 29, 38, 47, 56, 65

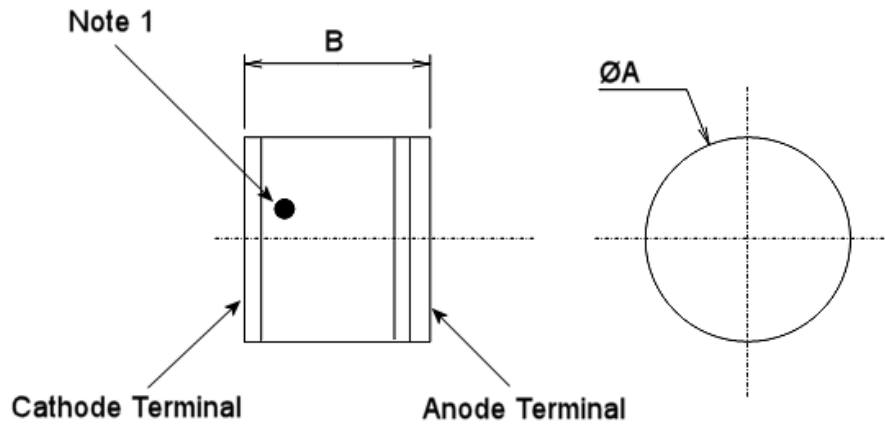

Symbols	Dimensions mm	
	Min	Max
ØA	1.07	1.47
B	0.95	1.35

NOTES:

1. Terminal identification: The body shall be marked at a suitable location near the cathode terminal with a black dot.

1.7.3 Ceramic Pill C (Cathode Lead) - Variants 03, 12, 21, 30, 39, 48, 57, 66

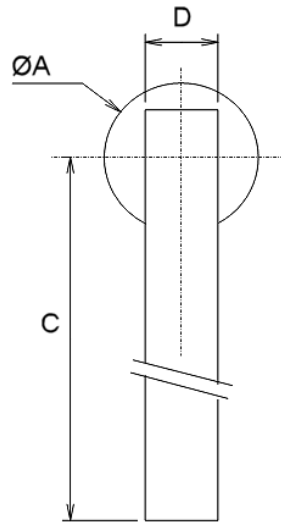
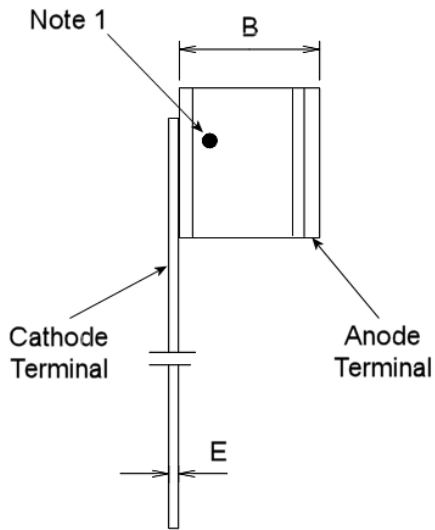

Symbols	Dimensions mm	
	Min	Max
ØA	1.07	1.47
B	0.95	1.35
C	5	-
D	0.55	0.65
E	0.06	0.1

NOTES:

- Terminal identification: The body shall be marked at a suitable location near the cathode terminal with a black dot.

1.7.4 Ceramic Pill D (Anode Lead) - Variants 04, 13, 22, 31, 40, 49, 58, 67

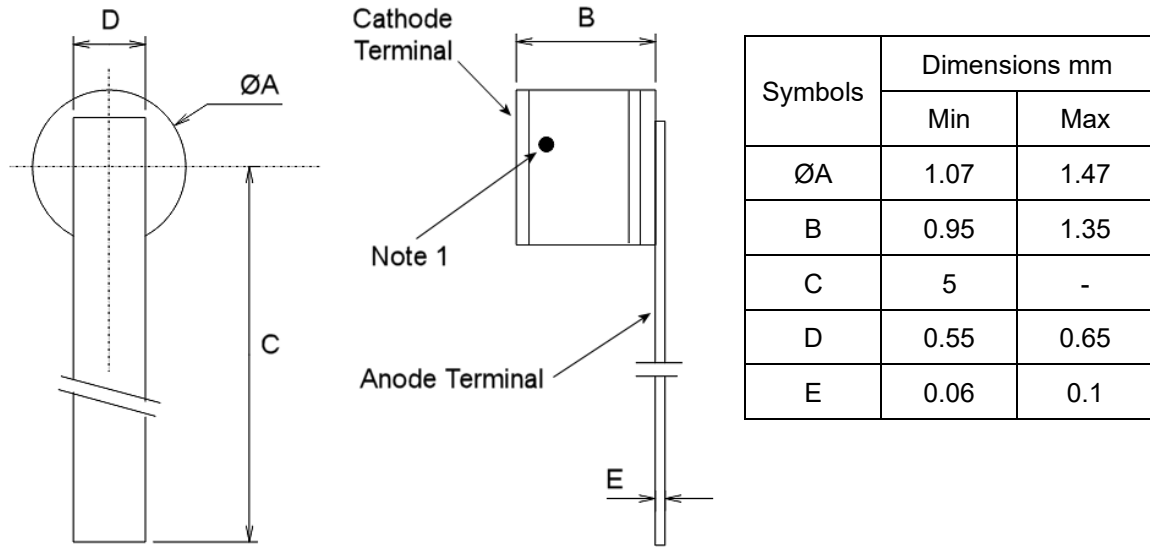

NOTES:

1. Terminal identification: The body shall be marked at a suitable location near the cathode terminal with a black dot.

1.7.5 Ceramic Pill E (2 Leads) - Variants 05, 14, 23, 32, 41, 50, 59, 68

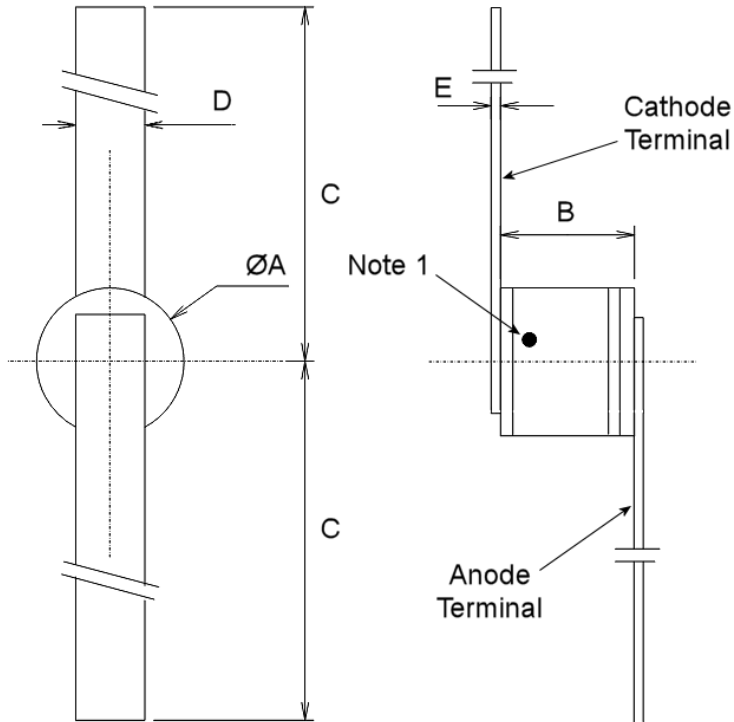

Symbols	Dimensions mm		Remarks
	Min	Max	
$\varnothing A$	1.07	1.47	
B	0.95	1.35	
C	5	-	
D	0.55	0.65	Both terminals
E	0.06	0.1	Both terminals

NOTES:

1. Terminal identification: The body shall be marked at a suitable location near the cathode terminal with a black dot.

1.7.6 Ceramic Pill F (Anode Lead) - Variants 06, 15, 24, 33, 42, 51, 60, 69

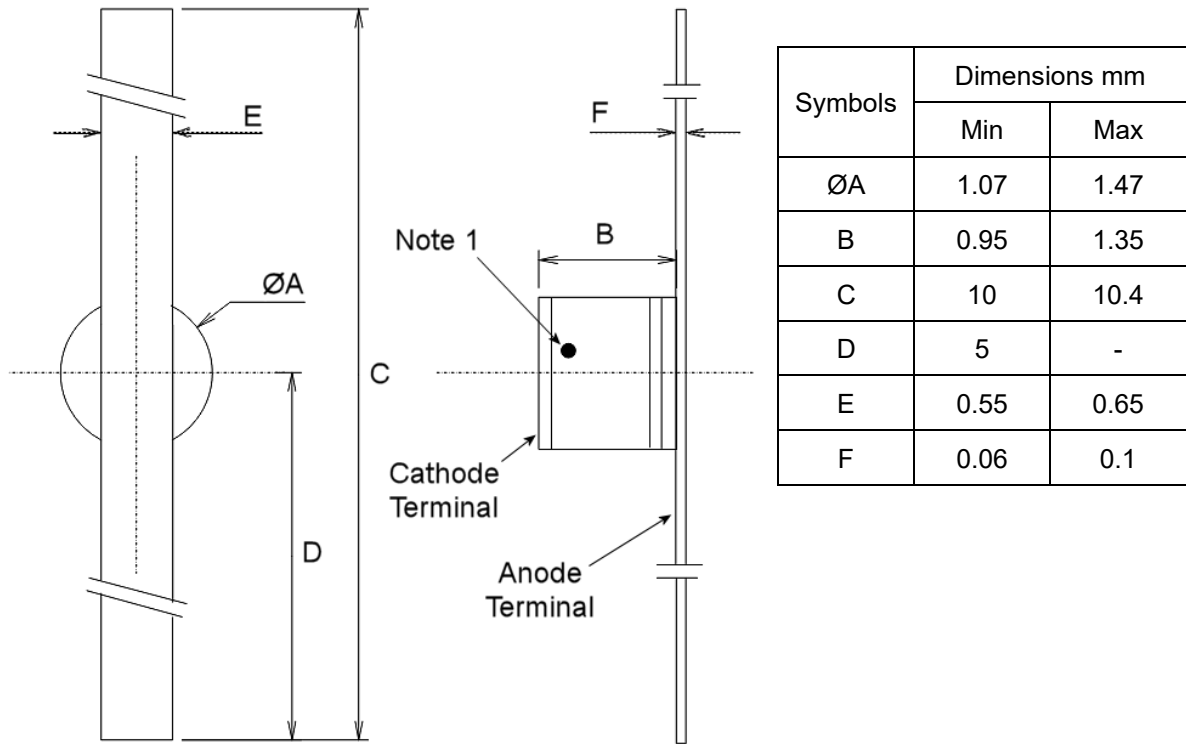

NOTES:

1. Terminal identification: The body shall be marked at a suitable location near the cathode terminal with a black dot.

1.7.7 Ceramic Pill G - Variants 07, 16, 25, 34, 43, 52, 61, 70

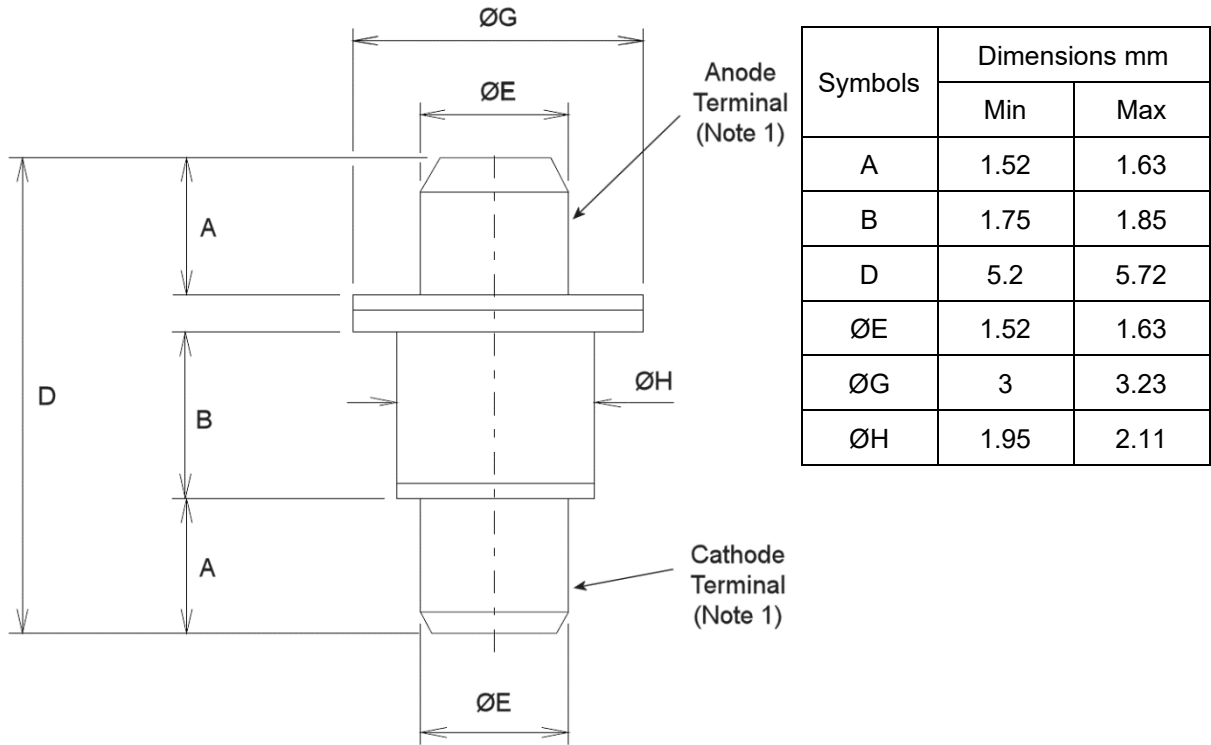

Symbols	Dimensions mm	
	Min	Max
A	1.52	1.63
B	1.75	1.85
D	5.2	5.72
ØE	1.52	1.63
ØG	3	3.23
ØH	1.95	2.11

NOTES:

1. Terminal identification shall be by means of the physical configuration of the package.

1.7.8 Die - Variants 73 to 80

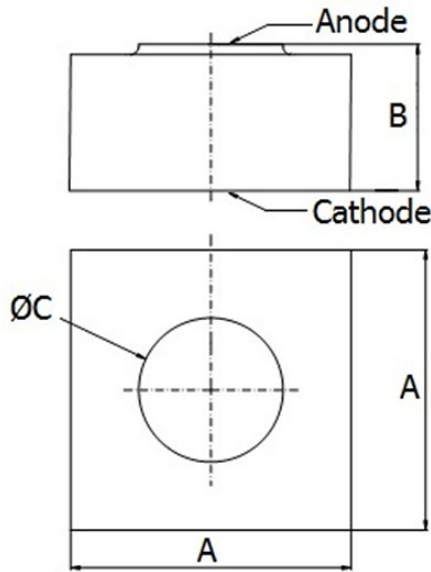

Symbols	Dimensions mm		Remarks
	Min	Max	
A	0.34	0.4	
B	0.16	0.26	
ØC	0.03	0.06	Variant 73
	0.05	0.08	Variant 74
	0.07	0.1	Variant 75
	0.09	0.12	Variant 76
	0.11	0.14	Variant 77
	0.13	0.16	Variant 78
	0.15	0.19	Variant 79
	0.18	0.23	Variant 80

NOTES:

1. Terminal identification shall be by means of the physical configuration.
2. Die construction, materials, finishes:
 - Die substrate: Silicon
 - Bond pad: The metallisation shall be TiPtAu with a layer of vacuum-deposited gold of thickness 0.7µm minimum.
 - Die backface: The metallisation shall be TiPtAu with a layer of gold of thickness 0.7µm minimum.
 - Glassivation: Silicon oxide or silicon nitride of thickness 0.25µm typical.

1.8 FUNCTIONAL DIAGRAM



1. Anode
2. Cathode

1.9 MATERIALS AND FINISHES

1.9.1 Materials and Finishes of Packaged Components

For Variants 01 to 07, 10 to 16, 19 to 25, 28 to 34, 37 to 43, 46 to 52, 55 to 61 and 64 to 70, the materials and finishes shall be as follows:

- (a) Case
The case shall be hermetically sealed and have a ceramic body with a metal base and lid.
- (b) Leads/Terminals
As specified in Para. 1.4.2.

1.9.2 Materials and Finishes of Die Components

For Variants 73 to 80, the materials and finishes shall be as specified in Para. 1.7.10.

2 REQUIREMENTS

2.1 GENERAL

The complete requirements for procurement of the components specified herein are as stated in this specification and the ESCC Generic Specification. Permitted deviations from the Generic Specification, applicable to this specification only, are listed below.

Permitted deviations from the Generic Specification and this Detail Specification, formally agreed with specific Manufacturers on the basis that the alternative requirements are equivalent to the ESCC requirement and do not affect the component's reliability, are listed in the appendices attached to this specification.

2.1.1 Deviations from the Generic Specification

2.1.1.1 *Deviations from Qualification and Periodic Tests – Chart F4*

- (a) Mechanical Shock: Shall not be performed.
- (b) Vibration: Shall not be performed.
- (c) Constant Acceleration: Shall not be performed.

2.2 MARKING

The marking shall be in accordance with the requirements of ESCC Basic Specification No. [21700](#) and as follows.

The information to be marked on the component or its primary package shall be:

- (a) Terminal identification, as specified in Para. 1.7.
- (b) The ESCC qualified components symbol (for ESCC qualified components only).
- (c) The ESCC Component Number.
- (d) Traceability information.

2.3 DIE SHEAR

In those cases where package clearances are such that a die shear test is not practicable, the die shall be pushed away with a suitable tool. The force required to remove the die need not be recorded. The die attachment area shall be inspected and the component shall be considered acceptable if more than 50% of the semiconductor material remains.

2.4 TERMINAL STRENGTH

The test conditions for terminal strength, tested as specified in the ESCC Generic Specification, shall be as follows:

- For Variants 01, 03 to 06, 10, 12 to 15, 19, 21 to 24, 28, 30 to 33, 37, 39 to 42, 46, 48 to 51, 55, 57 to 60, 64, 66 to 69: Test Condition A, tension, with a force of 1.25N for duration 10s.
- For Variants 02, 07, 11, 16, 20, 25, 29, 34, 38, 43, 47, 52, 56, 61, 65, 70: shall not be performed.
- For Variants 73 to 80: not applicable.

2.5 ELECTRICAL MEASUREMENTS AT ROOM, HIGH AND LOW TEMPERATURES

2.5.1 Room Temperature Electrical Measurements

The measurements shall be performed at $T_{amb} = +22 \pm 3^{\circ}C$.

Characteristics	Symbols	MIL-STD-750 Test Method	Test Conditions	Limits		Units
				Min	Max	
Reverse Current 1 (Note 1)	I_{R1}	4016	$V_R = -20V$	-	10	μA
Reverse Current 2 (Note 1)	I_{R2}	4016	$V_R = -16V$	-	50	nA
Forward Voltage (Note 1)	V_F	4011	$I_F = 10mA$	-	1	V
Total Capacitance (Note 2)	C_T	4001	$V_R = -4V, f = 1MHz$	Note 3	Note 3	pF
Junction Capacitance (Note 4)	C_J	4001	$V_R = -4V, f = 1MHz$	Note 3	Note 3	pF
Tuning Ratio (Notes 2, 5)	C_{T1}/C_{T12}	4001	$V_R = -1V$ and $-12V$ $f = 1MHz$	Note 3	Note 3	-
Tuning Ratio (Notes 4, 6)	C_{J1}/C_{J12}	4001	$V_R = -1V$ and $-12V$ $f = 1MHz$	Note 3	Note 3	-
Quality Factor (Note 7)	Q	-	$V_R = -4V, f = 1GHz$			-
Variants 01 to 07, 73:				100	-	
Variants 10 to 16, 74:				90	-	
Variants 19 to 25, 75:				75	-	
Variants 28 to 34, 76:				58	-	
Variants 37 to 43, 77:				40	-	
Variants 46 to 52, 78:				25	-	
Variants 55 to 61, 79:				12	-	
Variants 64 to 70, 80:				4	-	

NOTES:

1. This characteristic applies to all Variants tested during Charts F2 and F3 of the Generic Specification.
2. This characteristic applies to Variants 01 to 07, 10 to 16, 19 to 25, 28 to 34, 37 to 43, 46 to 52, 55 to 61 and 64 to 70 (Packaged Components) and Variants 73 to 80 (Packaged Test Sublot samples for Die Components), tested only during Chart F3 of the Generic Specification.
3. See Para. 1.4.2 for the applicable limits.
4. This characteristic applies only to Variants 73 to 80 (Die Components), tested only during Chart F2 of the Generic Specification.

5. For Variants 01 to 07, 10 to 16, 19 to 25, 28 to 34, 37 to 43, 46 to 52, 55 to 61 and 64 to 70 (Packaged Components) and Variants 73 to 80 (Packaged Test Sublot samples for Die Components) tested during Chart F3 of the Generic Specification, the Tuning Ratio is determined by dividing the Total Capacitance at $V_R = -1V$ by the Total Capacitance at $V_R = -12V$.
6. For Variants 73 to 80 (Die Components) tested during Chart F2 of the Generic Specification, the Tuning Ratio is determined by dividing the Junction Capacitance at $V_R = -1V$ by the Junction Capacitance at $V_R = -12V$.
7. Guaranteed but not tested.

2.5.2 High and Low Temperatures Electrical Measurements

The measurements shall be performed only at $T_{amb} = +150 (+0 -3)^{\circ}C$.

Characteristics	Symbols	MIL-STD-750 Test Method	Test Conditions Note 1	Limits		Units
				Min	Max	
Reverse Current 2 (Note 2)	I_{R2}	4016	$V_R = -16V$	-	10	μA

NOTES:

1. Measurements shall be performed on a sample basis as specified in the Generic Specification.
2. This characteristic applies to all Variants tested during Charts F2 and F3 of the Generic Specification.

2.6 PARAMETER DRIFT VALUES

Unless otherwise specified, the measurements shall be performed at $T_{amb} = +22 \pm 3^{\circ}C$.

The test methods and test conditions shall be as per the corresponding test defined in Para. 2.5.1, Room Temperature Electrical Measurements.

The drift values (Δ) shall not be exceeded for each characteristic specified. The corresponding absolute limit values for each characteristic shall not be exceeded.

Characteristics	Symbols	Limits			Units
		Drift Value (1) Δ	Absolute		
			Min	Max	
Reverse Current 2	I_{R2}	± 10 or (2) $\pm 100\%$	-	50	nA
Forward Voltage	V_F	$\pm 5\%$	-	1	V
Total Capacitance (Note 3)	C_T	$\pm 5\%$	Note 4	Note 4	pF

NOTES:

1. $\Delta 1 = \Delta 2$.
2. Whichever is the greater referred to the initial value.
3. This characteristic applies to Variants 01 to 07, 10 to 16, 19 to 25, 28 to 34, 37 to 43, 46 to 52, 55 to 61 and 64 to 70 (Packaged Components) and Variants 73 to 80 (Packaged Test Sublot samples for Die Components).

4. See Para. 1.4.2 for the applicable limits.

2.7 INTERMEDIATE AND END-POINT ELECTRICAL MEASUREMENTS

Unless otherwise specified, the measurements shall be performed at $T_{amb} = +22 \pm 3^{\circ}\text{C}$.

The test methods and test conditions shall be as per the corresponding test defined in Para. 2.5.1, Room Temperature Electrical Measurements.

The limit values for each characteristic shall not be exceeded.

Characteristics	Symbols	Limits		Units
		Min	Max	
Reverse Current 2	I_{R2}	-	20	μA
Forward Voltage	V_F	-	1	V
Total Capacitance (Note 1)	C_T	Note 2	Note 2	pF

NOTES:

1. This characteristic applies to Variants 01 to 07, 10 to 16, 19 to 25, 28 to 34, 37 to 43, 46 to 52, 55 to 61 and 64 to 70 (Packaged Components) and Variants 73 to 80 (Packaged Test Sublot samples for Die Components).
2. See Para. 1.4.2 for the applicable limits.

2.8 BURN-IN 1 CONDITIONS

Characteristics	Symbols	Test Conditions	Units
Ambient Temperature	T_{amb}	+125 (+0 -3)	$^{\circ}\text{C}$
Forward Current	I_F	50	mA

2.9 BURN-IN 2 CONDITIONS

Characteristics	Symbols	Test Conditions	Units
Ambient Temperature	T_{amb}	+150 (+0 -3)	$^{\circ}\text{C}$
Reverse Voltage	V_R	-16	V

2.10 OPERATING LIFE CONDITIONS

The conditions shall be as specified in Para. 2.9.

APPENDIX 'A'

AGREED DEVIATIONS FOR EXENS SOLUTIONS (F)

Items Affected	Description of Deviations
Para. 2.1.1, Deviations from the Generic Specification: Deviations from Special In-Process Controls – Chart F2	SEM Inspection: SEM inspection shall be performed on three dice from one wafer per metallisation run, selected after die separation. Bond Strength: The following pre-seal bond strength shall apply: <ul style="list-style-type: none"> • 0.03N minimum
Para. 2.1.1, Deviations from the Generic Specification: Deviations from Screening Tests for Packaged Components – Chart F3A	Radiographic Inspection: <ul style="list-style-type: none"> • May be performed without serialisation and at any point during Chart F3A. Any components found to fail Radiographic Inspection shall be removed from the lot. • May be performed in the X and Z axes only.
Para. 2.1.1.1, Deviations from Qualification and Periodic Tests – Chart F4	For the De-encapsulation Subgroup, the Internal Visual Inspection, Bond Strength and Die Shear tests may be replaced by measurements verifying the die solder integrity and wire integrity, as follows: <ul style="list-style-type: none"> • Thermal Impedance test in accordance with MIL-STD-750, Test Method 3101. <ul style="list-style-type: none"> • $P_D = 0.25W$. The Thermal Impedance shall be measured and shall not exceed 150°C/W. • Forward Voltage test in accordance with MIL-STD-750, Test Method 4011. <ul style="list-style-type: none"> • $I_F = 100mA$. The Forward Voltage shall be measured and shall not exceed 1.2V.