



Pages 1 to 18

TRANSISTORS, HIGH POWER, NPN

BASED ON TYPE 2N2880

ESCC Detail Specification No. 5203/025

Issue 2 - Draft A	October 2007
-------------------	--------------



Document Custodian: European Space Agency - see <https://escies.org>

LEGAL DISCLAIMER AND COPYRIGHT

European Space Agency, Copyright © 2007. All rights reserved.

The European Space Agency disclaims any liability or responsibility, to any person or entity, with respect to any loss or damage caused, or alleged to be caused, directly or indirectly by the use and application of this ESCC publication.

This publication, without the prior permission of the European Space Agency and provided that it is not used for a commercial purpose, may be:

- copied in whole, in any medium, without alteration or modification.
- copied in part, in any medium, provided that the ESCC document identification, comprising the ESCC symbol, document number and document issue, is removed.

DOCUMENTATION CHANGE NOTICE

(Refer to <https://escies.org> for ESCC DCR content)

DCR No.	CHANGE DESCRIPTION
TBD	Specification up issued to incorporate editorial and technical changes per DCR.

TABLE OF CONTENTS

<u>1.</u>	<u>GENERAL</u>	<u>5</u>
1.1	Scope	5
1.2	Applicable Documents	5
1.3	Terms, Definitions, Abbreviations, Symbols and Units	5
1.4	The ESCC Component Number and Component Type Variants	5
1.4.1	The ESCC Component Number	5
1.4.2	Component Type Variants	5
1.5	Maximum Ratings	5
1.6	Handling Precautions	7
1.7	Physical Dimensions and Terminal Identification	7
1.7.1	Metal Flange Mount Package (TO-257G) - 3 lead	8
1.7.2	Metal Flange Mount Package (TO-257) - 3 lead	9
1.7.3	Notes to Physical Dimensions and Terminal Identification	9
1.8	Functional Diagram	10
1.9	Materials and Finishes	10
<u>2.</u>	<u>REQUIREMENTS</u>	<u>10</u>
2.1	General	10
2.1.1	Deviations from the Generic Specification	10
2.1.1.1	Deviation from Screening Tests - Chart F3	10
2.2	Marking	11
2.3	Terminal Strength	11
2.4	Verification of Safe Operating Area	11
2.5	Electrical Measurements at Room, High and Low Temperatures	11
2.5.1	Room Temperature Electrical Measurements	11
2.5.2	High and Low Temperatures Electrical Measurements	15
2.6	Parameter Drift Values	16
2.7	Intermediate and End-Point Electrical Measurements	16
2.8	Power Burn-in Conditions	17
2.9	Operating Life Conditions	17
2.10	Total Dose Radiation Testing	17
2.10.1	Bias Conditions and Total Dose Level for Total Dose Radiation Testing	17
2.10.2	Electrical Measurements for Total Dose Radiation Testing	17

1. GENERAL

1.1 SCOPE

This specification details the ratings, physical and electrical characteristics and test and inspection data for the component type variants and/or the range of components specified below. It supplements the requirements of, and shall be read in conjunction with, the ESCC Generic Specification listed under Applicable Documents.

1.2 APPLICABLE DOCUMENTS

The following documents form part of this specification and shall be read in conjunction with it:

- (a) ESCC Generic Specification No. 5000
- (b) MIL-STD-750, Test Methods and Procedures for Semiconductor Devices

1.3 TERMS, DEFINITIONS, ABBREVIATIONS, SYMBOLS AND UNITS

For the purpose of this specification, the terms, definitions, abbreviations, symbols and units specified in ESCC Basic Specification No. 21300 shall apply.

1.4 THE ESCC COMPONENT NUMBER AND COMPONENT TYPE VARIANTS

1.4.1 The ESCC Component Number

The ESCC Component Number shall be constituted as follows:

Example: 520302510F

- Detail Specification Reference: 5203025
- Component Type Variant Number: 10 (as required)
- Total Dose Radiation Level Letter: F (as required)

1.4.2 Component Type Variants

The component type variants applicable to this specification are as follows:

Variant Number	Based on Type	Case	Lead/Terminal Material and Finish	Weight max g	Total Dose Radiation Level letter
10	2N2880	TO-257G	H3 or H4	5	F[50kRAD(Si)]
12	2N2880	TO-257	H3 or H4	5	F[50kRAD(Si)]

The lead/terminal material and finish shall be in accordance with the requirements of ESCC Basic Specification No. 23500.

The total dose radiation level letter shall be as defined in ESCC Basic Specification No. 22900. If an alternative radiation test level is specified in the Purchase Order the letter shall be changed accordingly.

1.5 MAXIMUM RATINGS

The maximum ratings shall not be exceeded at any time during use or storage.

Maximum ratings shall only be exceeded during testing to the extent specified in this specification and when stipulated in Test Methods and Procedures of the ESCC Generic Specification.

Characteristics	Symbols	Maximum Ratings	Unit	Remarks
Collector-Base Voltage	V_{CB}	150	V	Over T_{op}
Collector-Emitter Voltage	V_{CE}	80	V	Over T_{op}
Emitter-Base Voltage	V_{EB}	8	V	Over T_{op}
Collector Current	I_C	5	A	Continuous Note 3
Base Current	I_B	500	mA	Continuous
Power Dissipation	P_{tot}	20	W	At $T_{case} \leq +100^{\circ}C$ Note 1
Operating Temperature Range	T_{op}	-65 to +200	$^{\circ}C$	Note 2
Storage Temperature Range	T_{stg}	-65 to +200	$^{\circ}C$	Note 2
Soldering Temperature	T_{sol}	+260	$^{\circ}C$	Note 4
Thermal Resistance	$R_{th(j-c)}$	5	$^{\circ}C/W$	

NOTES:

- For $T_{case} > +100^{\circ}C$, derate linearly to 0W at +200 $^{\circ}C$.
- For Variants with tin-lead plating or hot solder dip lead finish all testing performed at $T_{amb} > +125^{\circ}C$

shall be carried out in a 100% inert atmosphere.

3. Safe operating area (continuous DC) applies as follows:

MAXIMUM SAFE OPERATING AREA GRAPH

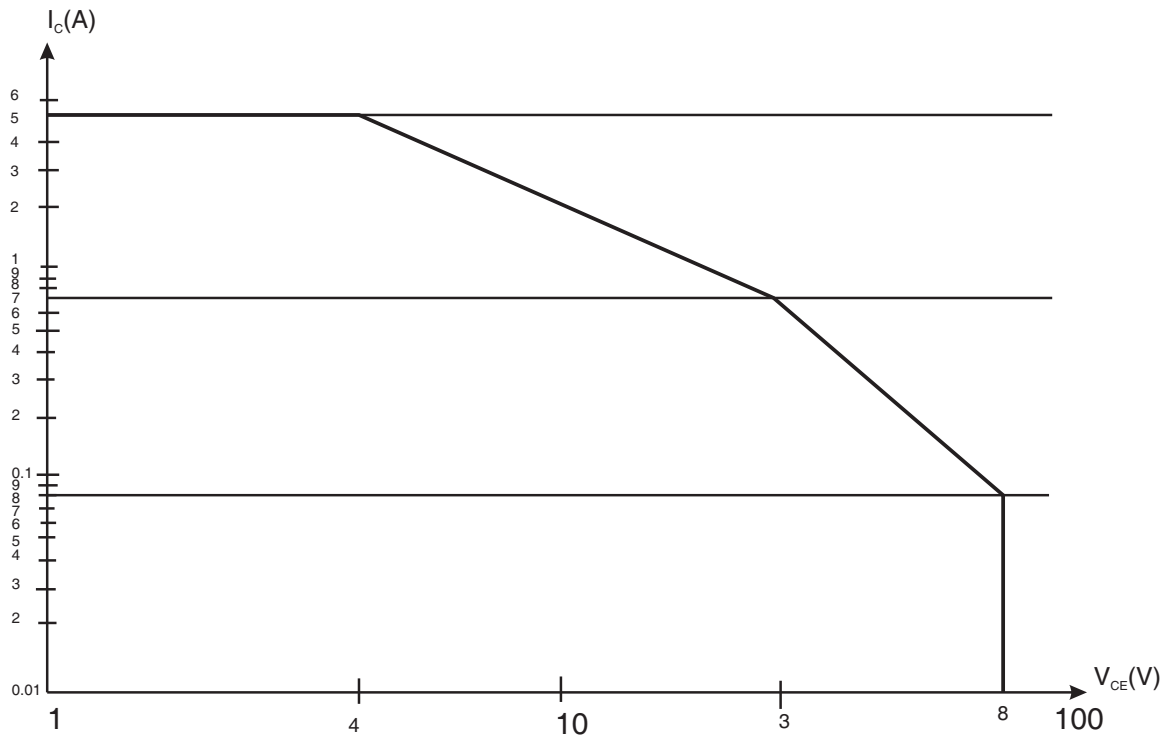

4. Duration 10 seconds maximum at a distance of not less than 1.5mm from the device body and the same lead shall not be resoldered until 3 minutes have elapsed.

1.6 HANDLING PRECAUTIONS

The TO-257G package and the TO-257 package both contain Beryllium Oxide (BeO) and therefore they must not be ground, machined, sandblasted or subjected to any mechanical operation which will produce dust. Their cases must not be subjected to any chemical processes (e.g. etching) which will produce fumes.

1.7 PHYSICAL DIMENSIONS AND TERMINAL IDENTIFICATION

Consolidated notes follow the case drawings and dimensions.

1.7.1 Metal Flange Mount Package (TO-257G) - 3 lead

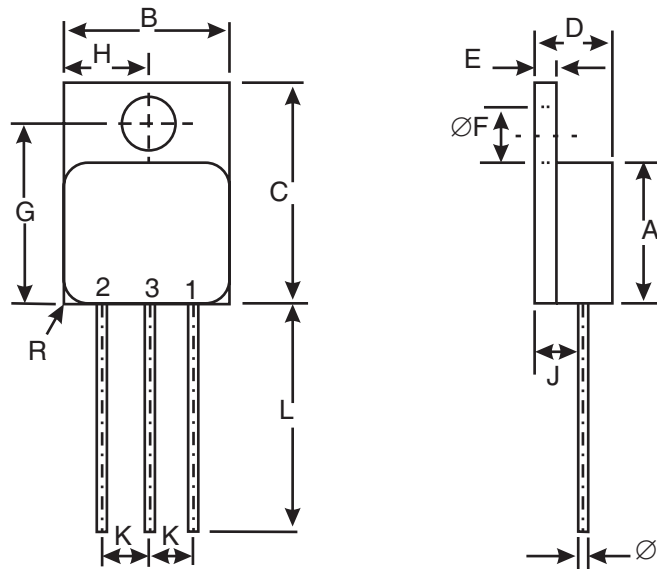

Symbols	Dimensions mm		Notes
	Min	Max	
A	10.41	10.92	
B	10.41	10.92	
C	16.26	17.02	
D	4.7	5.33	
E	0.64	0.89	
ØF	3.56	3.81	
G	13.2	13.72	
H	5.13	5.55	
ØI	0.89	1.14	2
J	2.65	2.75	2, 3
K	2.41	2.67	
L	12.7	14.73	
R	1.65 Typical		4

1.7.2 Metal Flange Mount Package (TO-257) - 3 lead

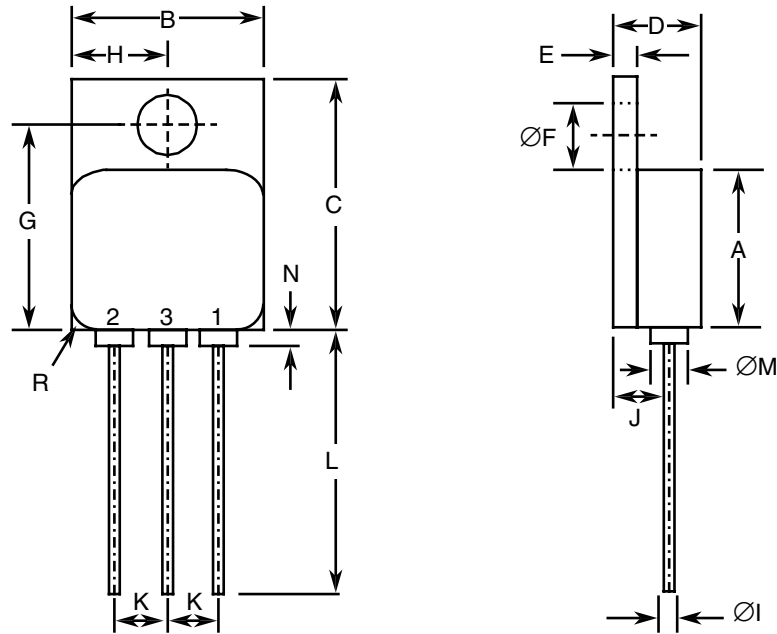

Symbols	Dimensions mm		Notes
	Min	Max	
A	10.41	10.92	
B	10.41	10.92	
C	16.26	17.02	
D	4.7	5.33	
E	0.64	0.89	
ØF	3.56	3.81	
G	13.2	13.72	
H	5.13	5.55	
ØI	0.89	1.14	2
J	2.65	2.75	2, 3
K	2.41	2.67	
L	12.7	14.73	
R	1.65 Typical		4

1.7.3 Notes to Physical Dimensions and Terminal Identification

1. Terminal identification is specified by the component's geometry where Lead 1 = emitter, Lead 2 = base and Lead 3 = collector.
2. Applies to all leads.
3. Measured from the seating plane to the centreline of the lead.
4. Radius of body corner, 4 places

1.8 FUNCTIONAL DIAGRAM

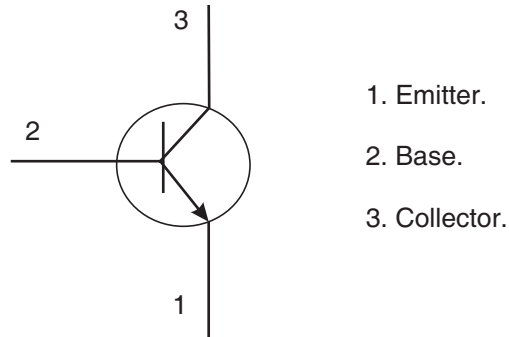

NOTES:

1. The case is not connected to any lead.

1.9 MATERIALS AND FINISHES

Materials and finishes shall be as follows:

- a) Case
For the TO-257G package the case shall be hermetically sealed and have a metal body with hard glass seals and the lid shall be welded.
For the TO-257 package the case shall be hermetically sealed and have a metal body. The leads pass through ceramic eyelets brazed into the frame and the lid shall be welded.
- b) Leads/Terminals
As specified in Component Type Variants.

2. REQUIREMENTS

2.1 GENERAL

The complete requirements for procurement of the components specified herein are as stated in this specification and the ESCC Generic Specification. Permitted deviations from the Generic Specification, applicable to this specification only, are listed below.

Permitted deviations from the Generic Specification and this Detail Specification, formally agreed with specific Manufacturers on the basis that the alternative requirements are equivalent to the ESCC requirement and do not affect the component's reliability, are listed in the appendices attached to this specification.

2.1.1 Deviations from the Generic Specification

2.1.1.1 *Deviation from Screening Tests - Chart F3*

High Temperature Reverse Bias Burn-in and the subsequent Final Measurements for HTRB shall be omitted.

2.2 **MARKING**

The marking shall be in accordance with the requirements of ESCC Basic Specification No. 21700 and as follows.

The information to be marked on the component shall be:

- (a) The ESCC qualified components symbol (for ESCC qualified components only).
- (b) The ESCC Component Number.
- (c) Traceability information.
- (d) Warning sign for Beryllium Oxide.

2.3 **TERMINAL STRENGTH**

The test conditions for terminal strength, tested as specified in the ESCC Generic Specification, shall be as follows:

Test condition A, tension, with an applied force of 20N for a duration of 15s.

2.4 **VERIFICATION OF SAFE OPERATING AREA**

The Safe Operating Area shall be verified as specified in the ESCC Generic Specification and Maximum Ratings herein. The test conditions shall be:

Test Method = MIL-STD-750, Method 3051, Continuous DC.

$T_{case} = +100(+0 - 5)^{\circ}C$.

Operating Time $\leq 1s$.

Test Number 1: $V_{CE} = 80V, I_C = 80mA$.

Test Number 2: $V_{CE} = 29V, I_C = 680mA$.

2.5 **ELECTRICAL MEASUREMENTS AT ROOM, HIGH AND LOW TEMPERATURES**

Electrical measurements shall be performed at room, high and low temperatures.

2.5.1 **Room Temperature Electrical Measurements**

The measurements shall be performed at $T_{amb} = +22 \pm 3^{\circ}C$.

Characteristics	Symbols	MIL-STD-750 Test Method	Test Conditions	Limits		Units
				Min	Max	
Collector-Emitter Breakdown Voltage	$V_{(BR)CEO}$	3011	$I_C = 100mA$ Bias condition D Note 1	80	-	V
Emitter-Base Breakdown Voltage	$V_{(BR)EBO}$	3026	$I_E = 10\mu A$ Bias condition D	8	-	V
Collector-Base Cut-off Current	I_{CBO}	3036	$V_{CB} = 60V$ Bias condition D	-	100	nA

Characteristics	Symbols	MIL-STD-750 Test Method	Test Conditions	Limits		Units
				Min	Max	
Collector-Emitter Cut-off Current	I_{CEX}	3041	$V_{CE}=150V$ $V_{BE}=-500mV$ Bias condition A	-	10	μA
	I_{CEO}	3041	$V_{CE}=50V$ Bias condition D	-	100	μA
Emitter-Base Cut- off Current	I_{EBO}	3061	$V_{EB}=5V$ Bias condition D	-	100	nA
Forward-Current Transfer Ratio	h_{FE1}	3076	$V_{CE}=5V, I_C=1A$ Note 1	40	120	-
	h_{FE2}	3076	$V_{CE}=5V, I_C=5A$ Note 1	15	-	-
Collector-Emitter Saturation Voltage	$V_{CE(sat)1}$	3071	$I_C=1A$ $I_B=100mA$ Note 1	-	250	mV
	$V_{CE(sat)2}$	3071	$I_C=5A$ $I_B=500mA$ Note 1 Test Condition A	-	2	V
Base-Emitter Saturation Voltage	$V_{BE(sat)1}$	3066	$I_C=1A$ $I_B=100mA$ Test Condition A Note 1	-	1.2	V
Magnitude of Small-Signal Short-Circuit Forward-Current Transfer Ratio	$ h_{fe} $	3306	$V_{CE}=10V$ $I_C=1A$ $f=10MHz$ Notes 1, 2	3	-	-
Output Capacitance	C_{obo}	3236	$V_{CB}=10V$ $I_E=0A$ $f=1MHz$ Note 2	-	150	pF
Pulse Rise Time, Unsaturated Mode	$t_{r(u)}$	-	$I_C=1A$ $I_B=100mA$ $V_{CC}=25V$ $V_{BB}=10V$ Notes 2, 3	-	80	ns
Pulse Storage Time, Unsaturated Mode	$t_{s(u)}$	-	$I_C=1A$ $I_B=100mA$ $V_{CC}=25V$ $V_{BB}=10V$ Notes 2, 3	-	60	ns

Characteristics	Symbols	MIL-STD-750 Test Method	Test Conditions	Limits		Units
				Min	Max	
Pulse Fall Time, Unsaturation Mode	$t_{f(u)}$	-	$I_C=1A$ $I_B=100mA$ $V_{CC}=25V$ $V_{BB}=10V$ Notes 2, 3	-	80	ns
Pulse Rise Time, Saturated Mode	$t_{r(s)}$	-	$I_C=1A$ $I_B=100mA$ $V_{CC}=20V$ $V_{BB}=10V$ Notes 2, 4	-	300	ns
Pulse Storage Time, Saturated Mode	$t_{s(s)}$	-	$I_C=1A$ $I_B=100mA$ $V_{CC}=20V$ $V_{BB}=10V$ Notes 2, 4	-	2	μs
Pulse Fall Time, Saturated Mode	$t_{f(s)}$	-	$I_C=1A$ $I_B=100mA$ $V_{CC}=20V$ $V_{BB}=10V$ Notes 2, 4	-	350	ns

NOTES:

1. Pulsed measurement: Pulse Width $\leq 330\mu s$, Duty Cycle $\leq 2\%$.
2. For AC characteristics read and record measurements shall be performed on a sample of 32 components with 0 failures allowed. Alternatively a 100% inspection may be performed.
3. Unsaturation mode pulse times shall be measured using the following test circuit:

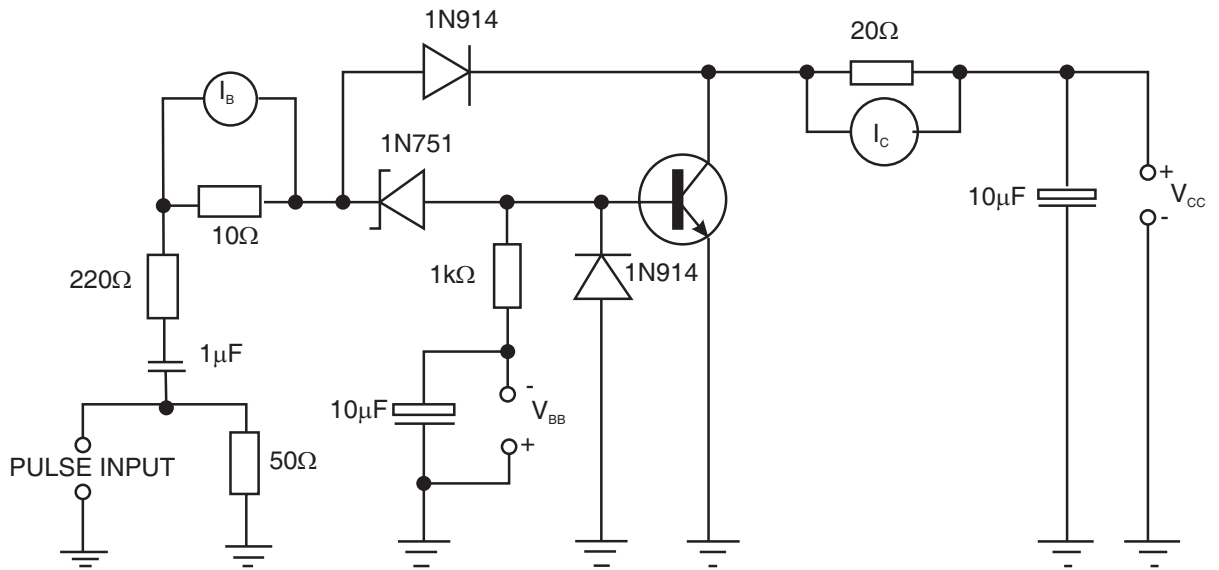

VOLTAGE WAVEFORMS

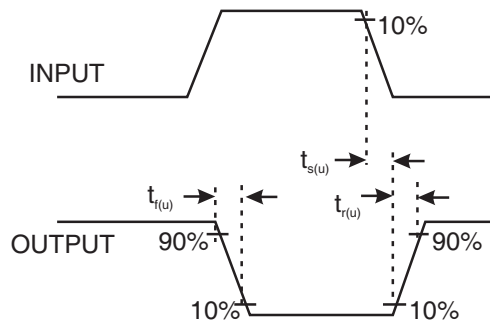

4. Saturated mode pulse times shall be measured using the following test circuit:

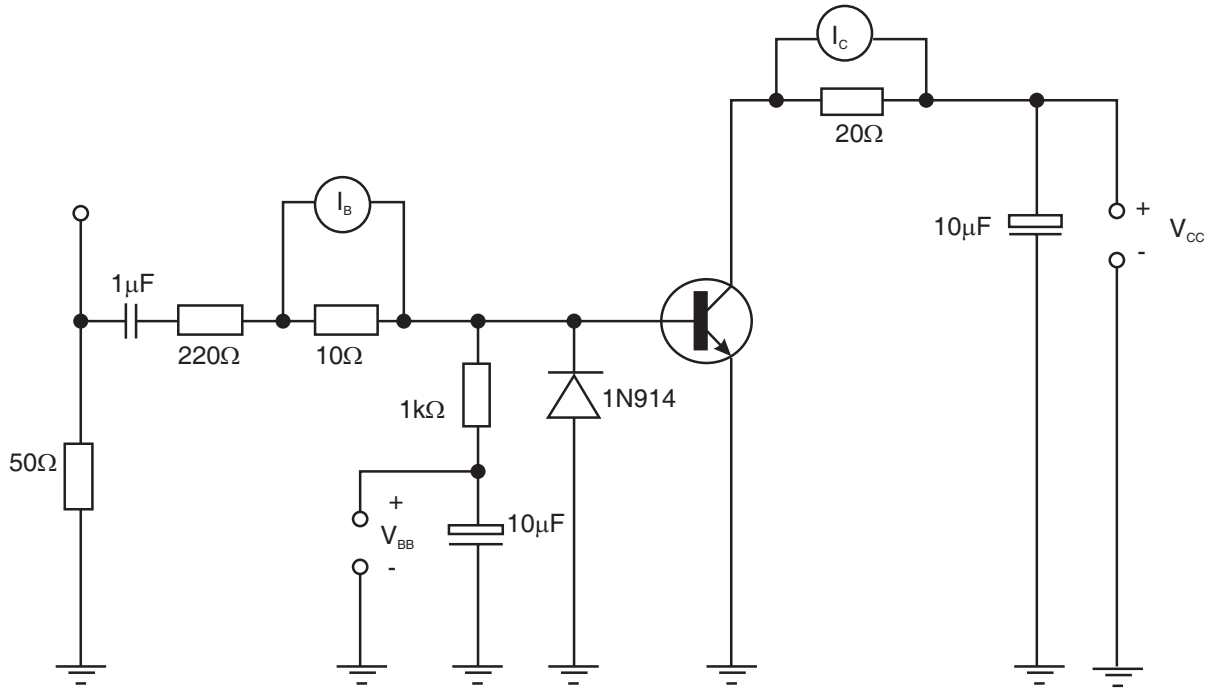

VOLTAGE WAVEFORMS

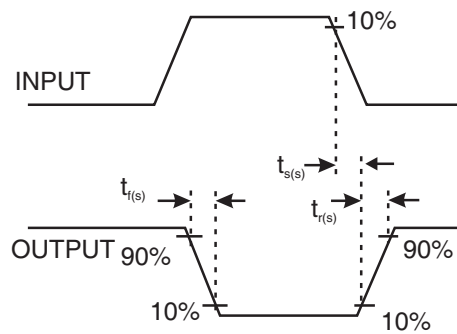

2.5.2 High and Low Temperatures Electrical Measurements

Characteristics	Symbols	MIL-STD-750 Test Method	Test Conditions Note 1	Limits		Units
				Min	Max	
Collector-Base Cut-off Current	I_{CBO}	3036	$T_{amb}=+150(+0-5)^{\circ}C$ $V_{CB}=60V$ Bias condition D	-	50	μA

Characteristics	Symbols	MIL-STD-750 Test Method	Test Conditions Note 1	Limits		Units
				Min	Max	
Forward-Current Transfer Ratio 1	h_{FE1}	3076	$T_{amb}=-55(+0-5)^{\circ}C$ $V_{CE}=5V ; I_C =1A$ Note 2	15	-	-

NOTES:

1. Read and record measurements shall be performed on a sample of 5 components with 0 failures allowed. Alternatively a 100% inspection may be performed.
2. Pulsed measurement: Pulse Width $\leq 330\mu s$, Duty Cycle $\leq 2\%$.

2.6 PARAMETER DRIFT VALUES

Unless otherwise specified, the measurements shall be performed at $T_{amb}=+22 \pm 3^{\circ}C$.

The test methods and test conditions shall be as per the corresponding test defined in Room Temperature Electrical Measurements.

The drift values (Δ) shall not be exceeded for each characteristic specified. The corresponding absolute limit values for each characteristic shall not be exceeded.

Characteristics	Symbols	Limits			Units
		Drift Value Δ	Absolute		
			Min	Max	
Collector-Emitter Cut-off Current	I_{CEX}	± 1	-	10	μA
Forward-Current Transfer Ratio 1	h_{FE1}	$\pm 25\%$	40	120	-
Collector-Emitter Saturation Voltage 1	$V_{CE(sat)1}$	± 50	-	250	mV

2.7 INTERMEDIATE AND END-POINT ELECTRICAL MEASUREMENTS

Unless otherwise specified, the measurements shall be performed at $T_{amb}=+22 \pm 3^{\circ}C$.

The test methods and test conditions shall be as per the corresponding test defined in Room Temperature Electrical Measurements.

The limit values for each characteristic shall not be exceeded.

Characteristics	Symbols	Limits		Units
		Min	Max	
Collector-Emitter Cut-off Current	I_{CEX}	-	10	μA
Forward-Current Transfer Ratio 1	h_{FE1}	40	120	-
Collector-Emitter Saturation Voltage 1	$V_{CE(sat)1}$	-	250	mV

2.8 POWER BURN-IN CONDITIONS

Characteristics	Symbols	Conditions	Units
Case Temperature	T_{case}	+100 (+0 -5)	°C
Power Dissipation	P_{tot}	20	W
Collector-Base Voltage	V_{CB}	10	V

2.9 OPERATING LIFE CONDITIONS

The conditions shall be as specified for Power Burn-in.

2.10 TOTAL DOSE RADIATION TESTING

2.10.1 Bias Conditions and Total Dose Level for Total Dose Radiation Testing

Continuous bias shall be applied during radiation testing as specified below.

The total dose level applied shall be as specified in the component type variant information herein or in the Purchase Order.

Characteristics	Symbols	Test Conditions	Units
Ambient Temperature	T_{amb}	+ 22 ± 3	°C
Collector-Emitter Voltage	V_{CE}	70	V

NOTES:

1. Resistor $R_C = 2.2k\Omega$. Bias circuit is shown below:

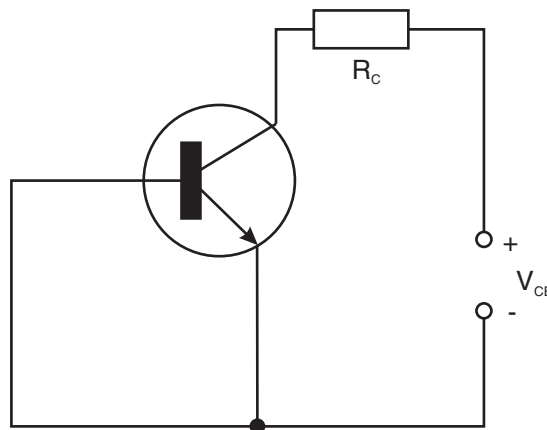

2.10.2 Electrical Measurements for Total Dose Radiation Testing

Prior to radiation testing the devices shall have successfully met Room Temperature Electrical Measurements specified herein.

Unless otherwise stated the measurements shall be performed at $T_{amb} = +22 \pm 3^\circ\text{C}$.

The test methods and test conditions shall be as per the corresponding test defined in Room

Temperature Electrical Measurements.

The parameters to be measured during and on completion of radiation testing are shown below.

Characteristics	Symbols	Limits			Units
		Drift Values Δ	Absolute		
			Min	Max	
Collector-Base Cut-off Current	I_{CBO}	± 10	-	100	nA
Emitter-Base Cut-off Current	I_{EBO}	± 100	-	100	nA
Forward-Current Transfer Ratio	h_{FE1}	-	40	120	-
	h_{FE2}	-	15	-	-
Collector-Emitter Saturation Voltage 1	$V_{CE(sat)1}$	± 75	-	250	mV