



**CAPACITORS, FIXED, MULTIPLE LAYER,  
CERAMIC DIELECTRIC, TYPE II**

**BASED ON TYPES CNC53, CNC54, CNC55, CNC56,  
CNC57, CNC58 AND CNC65**

**ESCC Detail Specification No. 3001/038**

Issue 2 Draft D	September 2016
-----------------	----------------



**LEGAL DISCLAIMER AND COPYRIGHT**

European Space Agency, Copyright © 2016. All rights reserved.

The European Space Agency disclaims any liability or responsibility, to any person or entity, with respect to any loss or damage caused, or alleged to be caused, directly or indirectly by the use and application of this ESCC publication.

This publication, without the prior permission of the European Space Agency and provided that it is not used for a commercial purpose, may be:

- copied in whole, in any medium, without alteration or modification.
- copied in part, in any medium, provided that the ESCC document identification, comprising the ESCC symbol, document number and document issue, is removed.

**DOCUMENTATION CHANGE NOTICE**

(Refer to <https://escies.org> for ESCC DCR content)

DCR No.	CHANGE DESCRIPTION
728	Specification updated to incorporate changes per DCR. Specification produced in MSWORD. Changes in presentation are possible.

**TABLE OF CONTENTS**

1	GENERAL	5
1.1	SCOPE	5
1.2	APPLICABLE DOCUMENTS	5
1.3	TERMS, DEFINITIONS, ABBREVIATIONS, SYMBOLS AND UNITS	5
1.4	THE ESCC COMPONENT NUMBER AND COMPONENT TYPE VARIANTS	5
1.4.1	The ESCC Component Number	5
1.4.2	Component Type Variants and Range of Components	6
1.5	MAXIMUM RATINGS	10
1.6	PHYSICAL DIMENSIONS	11
1.6.1	Variants 01 to 07 (lead type N)	11
1.6.2	Variants 08 to 14 (lead type P)	12
1.6.3	Variants 15 to 21 (lead type PL)	13
1.6.4	Variants 22 to 28 (lead type L)	14
1.7	FUNCTIONAL DIAGRAM	14
2	REQUIREMENTS	15
2.1	GENERAL	15
2.1.1	Deviations from the Generic Specification	15
2.2	MARKING	15
2.3	ROBUSTNESS OF TERMINATIONS	15
2.4	ELECTRICAL MEASUREMENTS AT ROOM, HIGH AND LOW TEMPERATURES	16
2.4.1	Room Temperature Electrical Measurements	16
2.4.2	High and Low Temperatures Electrical Measurements	17
2.5	INTERMEDIATE AND END-POINT ELECTRICAL MEASUREMENTS	17
2.6	BURN-IN	19
	APPENDIX A	20

## 1 GENERAL

### 1.1 SCOPE

This specification details the ratings, physical and electrical characteristics, and test and inspection data for the component type variants and/or the range of components specified below. It supplements the requirements of, and shall be read in conjunction with, the ESCC Generic Specification listed under Applicable Documents.

### 1.2 APPLICABLE DOCUMENTS

The following documents form part of this specification and shall be read in conjunction with it:

- (a) ESCC Generic Specification No. [3001](#).

### 1.3 TERMS, DEFINITIONS, ABBREVIATIONS, SYMBOLS AND UNITS

For the purpose of this specification, the terms, definitions, abbreviations, symbols and units specified in ESCC Basic Specification No. [21300](#) shall apply.

### 1.4 THE ESCC COMPONENT NUMBER AND COMPONENT TYPE VARIANTS

#### 1.4.1 The ESCC Component Number

The ESCC Component Number shall be constituted as follows:

Example: 300103801126KC

- Detail Specification Reference: 3001038
- Component Type Variant Number: 01 (as required)
- Characteristic code: Capacitance Value (12 $\mu$ F): 126 (as required)
- Characteristic code: Capacitance Tolerance ( $\pm$ 10%): K (as required)
- Rating code: Rated Voltage (50V): C (as required)

#### 1.4.1.1 *Characteristics and Ratings Codes*

Characteristics and ratings to be codified as part of the ESCC Component Number shall be as follows:

- (a) Rated Capacitance Value  $C_n$  expressed by means of the following codes in accordance with ESCC Basic Specification No. [21700](#). The unit quantity shall be picofarad (pF).

Capacitance Value $C_n$ (pF)	Code
XX 10 <sup>4</sup>	XX4
XX 10 <sup>5</sup>	XX5
XX 10 <sup>6</sup>	XX6
XX 10 <sup>7</sup>	XX7

- (b) Capacitance Tolerance expressed by the following codes in accordance with ESCC Basic Specification No. 21700:

Tolerance (± %)	Code Letter
10	K
20	M

- (c) Rated Voltage expressed by the following codes:

Rated Voltage (V)	Code Letter
50	C
100	E
200	G
500	L

1.4.2 Component Type Variants and Range of Components

The component type variants and range of components applicable to this specification are as follows:

Variant Number	Package Details (Note 1)					Capacitance Range C <sub>n</sub> (μF) (Note 4)				Weight Max (g)
	Type (Note 2)	Lead Type	Lead Mat. & Fin. (Note 3)	No. of Leads	Dim. H Max (mm)	Rated Voltage U <sub>R</sub> = 50V	Rated Voltage U <sub>R</sub> = 100V	Rated Voltage U <sub>R</sub> = 200V	Rated Voltage U <sub>R</sub> = 500V	
01	CNC53NE	N	A10	6	4	1.8 to 3.3	1 to 2.7	0.27 to 0.68	0.1 to 0.22	2
					8	3.9 to 6.8	3.3 to 5.6	0.82 to 1.2	0.27 to 0.47	3.5
					12	8.2 to 10	6.8 to 8.2	1.5 to 1.8	0.56 to 0.68	5
					16	12	10	2.2 to 2.7	0.82 to 1	6.5
02	CNC54NE	N	A10	8	4	3.3 to 5.6	1.8 to 3.9	0.47 to 1	0.22 to 0.39	3
					8	6.8 to 10	4.7 to 8.2	1.2 to 2.2	0.47 to 0.82	5.5
					12	12 to 15	10 to 12	2.7 to 3.3	1 to 1.2	8.5
					16	18 to 22	15	3.9	1.5	11
03	CNC55NE	N	A10	10	4	6.8 to 10	2.7 to 8.2	1 to 2.2	0.33 to 0.82	4.5
					8	12 to 22	10 to 15	2.7 to 4.7	1 to 1.8	9
					12	27 to 33	18 to 22	5.6 to 6.8	2.2 to 2.7	13.5
					16	39	27 to 33	8.2 to 10	3.3	18
04	CNC56NE	N	A10	14	4	10 to 18	4.7 to 15	1.8 to 3.9	0.47 to 1.5	6.5
					8	22 to 39	18 to 27	4.7 to 6.8	1.8 to 3.3	13
					12	47 to 56	33 to 39	8.2 to 10	3.9 to 4.7	19.5
					16	68	47	12	5.6	26

Variant Number	Package Details (Note 1)					Capacitance Range C <sub>n</sub> ( $\mu$ F) (Note 4)				Weight Max (g)
	Type (Note 2)	Lead Type	Lead Mat. & Fin. (Note 3)	No. of Leads	Dim. H Max (mm)	Rated Voltage U <sub>R</sub> = 50V	Rated Voltage U <sub>R</sub> = 100V	Rated Voltage U <sub>R</sub> = 200V	Rated Voltage U <sub>R</sub> = 500V	
05	CNC57NE	N	A10	28	4	15 to 22	12 to 18	2.2 to 3.9	0.82 to 1.5	7.5
					8	27 to 47	22 to 39	4.7 to 8.2	1.8 to 3.3	15
					12	56 to 68	47 to 56	10 to 12	3.9 to 4.7	22.5
					16	82	68	15	5.6	30
06	CNC58NE	N	A10	28	4	39 to 47	33 to 39	8.2 to 10	2.7 to 4.7	15
					8	56 to 100	47 to 82	12 to 22	5.6 to 10	30
					12	120 to 150	100 to 120	27 to 33	12 to 15	45
					16	180	150	39	18	60
07	CNC65NE	N	A10	12	4	10 to 18	4.7 to 15	1.8 to 3.9	0.47 to 1.5	6.5
					8	22 to 39	18 to 27	4.7 to 6.8	1.8 to 3.3	13
					12	47 to 56	33 to 39	8.2 to 10	3.9 to 4.7	19.5
					16	68	47	12	5.6	26
08	CNC53PE	P	A10	6	4	1.8 to 3.3	1 to 2.7	0.27 to 0.68	0.1 to 0.22	2
					8	3.9 to 6.8	3.3 to 5.6	0.82 to 1.2	0.27 to 0.47	3.5
					12	8.2 to 10	6.8 to 8.2	1.5 to 1.8	0.56 to 0.68	5
					16	12	10	2.2 to 2.7	0.82 to 1	6.5
09	CNC54PE	P	A10	8	4	3.3 to 5.6	1.8 to 3.9	0.47 to 1	0.22 to 0.39	3
					8	6.8 to 10	4.7 to 8.2	1.2 to 2.2	0.47 to 0.82	5.5
					12	12 to 15	10 to 12	2.7 to 3.3	1 to 1.2	8.5
					16	18 to 22	15	3.9	1.5	11
10	CNC55PE	P	A10	10	4	6.8 to 10	2.7 to 8.2	1 to 2.2	0.33 to 0.82	4.5
					8	12 to 22	10 to 15	2.7 to 4.7	1 to 1.8	9
					12	27 to 33	18 to 22	5.6 to 6.8	2.2 to 2.7	13.5
					16	39	27 to 33	8.2 to 10	3.3	18
11	CNC56PE	P	A10	14	4	10 to 18	4.7 to 15	1.8 to 3.9	0.47 to 1.5	6.5
					8	22 to 39	18 to 27	4.7 to 6.8	1.8 to 3.3	13
					12	47 to 56	33 to 39	8.2 to 10	3.9 to 4.7	19.5
					16	68	47	12	5.6	26
12	CNC57PE	P	A10	28	4	15 to 22	12 to 18	2.2 to 3.9	0.82 to 1.5	7.5
					8	27 to 47	22 to 39	4.7 to 8.2	1.8 to 3.3	15
					12	56 to 68	47 to 56	10 to 12	3.9 to 4.7	22.5
					16	82	68	15	5.6	30

Variant Number	Package Details (Note 1)					Capacitance Range C <sub>n</sub> ( $\mu$ F) (Note 4)				Weight Max (g)
	Type (Note 2)	Lead Type	Lead Mat. & Fin. (Note 3)	No. of Leads	Dim. H Max (mm)	Rated Voltage U <sub>R</sub> = 50V	Rated Voltage U <sub>R</sub> = 100V	Rated Voltage U <sub>R</sub> = 200V	Rated Voltage U <sub>R</sub> = 500V	
13	CNC58PE	P	A10	28	4	39 to 47	33 to 39	8.2 to 10	2.7 to 4.7	15
					8	56 to 100	47 to 82	12 to 22	5.6 to 10	30
					12	120 to 150	100 to 120	27 to 33	12 to 15	45
					16	180	150	39	18	60
14	CNC65PE	P	A10	12	4	10 to 18	4.7 to 15	1.8 to 3.9	0.47 to 1.5	6.5
					8	22 to 39	18 to 27	4.7 to 6.8	1.8 to 3.3	13
					12	47 to 56	33 to 39	8.2 to 10	3.9 to 4.7	19.5
					16	68	47	12	5.6	26
15	CNC53PLE	PL	A10	6	4	1.8 to 3.3	1 to 2.7	0.27 to 0.68	0.1 to 0.22	2
					8	3.9 to 6.8	3.3 to 5.6	0.82 to 1.2	0.27 to 0.47	3.5
					12	8.2 to 10	6.8 to 8.2	1.5 to 1.8	0.56 to 0.68	5
					16	12	10	2.2 to 2.7	0.82 to 1	6.5
16	CNC54PLE	PL	A10	8	4	3.3 to 5.6	1.8 to 3.9	0.47 to 1	0.22 to 0.39	3
					8	6.8 to 10	4.7 to 8.2	1.2 to 2.2	0.47 to 0.82	5.5
					12	12 to 15	10 to 12	2.7 to 3.3	1 to 1.2	8.5
					16	18 to 22	15	3.9	1.5	11
17	CNC55PLE	PL	A10	10	4	6.8 to 10	2.7 to 8.2	1 to 2.2	0.33 to 0.82	4.5
					8	12 to 22	10 to 15	2.7 to 4.7	1 to 1.8	9
					12	27 to 33	18 to 22	5.6 to 6.8	2.2 to 2.7	13.5
					16	39	27 to 33	8.2 to 10	3.3	18
18	CNC56PLE	PL	A10	14	4	10 to 18	4.7 to 15	1.8 to 3.9	0.47 to 1.5	6.5
					8	22 to 39	18 to 27	4.7 to 6.8	1.8 to 3.3	13
					12	47 to 56	33 to 39	8.2 to 10	3.9 to 4.7	19.5
					16	68	47	12	5.6	26
19	CNC57PLE	PL	A10	28	4	15 to 22	12 to 18	2.2 to 3.9	0.82 to 1.5	7.5
					8	27 to 47	22 to 39	4.7 to 8.2	1.8 to 3.3	15
					12	56 to 68	47 to 56	10 to 12	3.9 to 4.7	22.5
					16	82	68	15	5.6	30
20	CNC58PLE	PL	A10	28	4	39 to 47	33 to 39	8.2 to 10	2.7 to 4.7	15
					8	56 to 100	47 to 82	12 to 22	5.6 to 10	30
					12	120 to 150	100 to 120	27 to 33	12 to 15	45
					16	180	150	39	18	60



Variant Number	Package Details (Note 1)					Capacitance Range C <sub>n</sub> (μF) (Note 4)				Weight Max (g)
	Type (Note 2)	Lead Type	Lead Mat. & Fin. (Note 3)	No. of Leads	Dim. H Max (mm)	Rated Voltage U <sub>R</sub> = 50V	Rated Voltage U <sub>R</sub> = 100V	Rated Voltage U <sub>R</sub> = 200V	Rated Voltage U <sub>R</sub> = 500V	
21	CNC65PLE	PL	A10	12	4	10 to 18	4.7 to 15	1.8 to 3.9	0.47 to 1.5	6.5
					8	22 to 39	18 to 27	4.7 to 6.8	1.8 to 3.3	13
					12	47 to 56	33 to 39	8.2 to 10	3.9 to 4.7	19.5
					16	68	47	12	5.6	26
22	CNC53LE	L	A10	6	4	1.8 to 3.3	1 to 2.7	0.27 to 0.68	0.1 to 0.22	2
					8	3.9 to 6.8	3.3 to 5.6	0.82 to 1.2	0.27 to 0.47	3.5
					12	8.2 to 10	6.8 to 8.2	1.5 to 1.8	0.56 to 0.68	5
					16	12	10	2.2 to 2.7	0.82 to 1	6.5
23	CNC54LE	L	A10	8	4	3.3 to 5.6	1.8 to 3.9	0.47 to 1	0.22 to 0.39	3
					8	6.8 to 10	4.7 to 8.2	1.2 to 2.2	0.47 to 0.82	5.5
					12	12 to 15	10 to 12	2.7 to 3.3	1 to 1.2	8.5
					16	18 to 22	15	3.9	1.5	11
24	CNC55LE	L	A10	10	4	6.8 to 10	2.7 to 8.2	1 to 2.2	0.33 to 0.82	4.5
					8	12 to 22	10 to 15	2.7 to 4.7	1 to 1.8	9
					12	27 to 33	18 to 22	5.6 to 6.8	2.2 to 2.7	13.5
					16	39	27 to 33	8.2 to 10	3.3	18
25	CNC56LE	L	A10	14	4	10 to 18	4.7 to 15	1.8 to 3.9	0.47 to 1.5	6.5
					8	22 to 39	18 to 27	4.7 to 6.8	1.8 to 3.3	13
					12	47 to 56	33 to 39	8.2 to 10	3.9 to 4.7	19.5
					16	68	47	12	5.6	26
26	CNC57LE	L	A10	28	4	15 to 22	12 to 18	2.2 to 3.9	0.82 to 1.5	7.5
					8	27 to 47	22 to 39	4.7 to 8.2	1.8 to 3.3	15
					12	56 to 68	47 to 56	10 to 12	3.9 to 4.7	22.5
					16	82	68	15	5.6	30
27	CNC58LE	L	A10	28	4	39 to 47	33 to 39	8.2 to 10	2.7 to 4.7	15
					8	56 to 100	47 to 82	12 to 22	5.6 to 10	30
					12	120 to 150	100 to 120	27 to 33	12 to 15	45
					16	180	150	39	18	60
28	CNC65LE	L	A10	12	4	10 to 18	4.7 to 15	1.8 to 3.9	0.47 to 1.5	6.5
					8	22 to 39	18 to 27	4.7 to 6.8	1.8 to 3.3	13
					12	47 to 56	33 to 39	8.2 to 10	3.9 to 4.7	19.5
					16	68	47	12	5.6	26

**NOTES:**

1. See Physical Dimensions and Functional Diagram.

2. For Variants 01 to 07 the body shall be coated with varnish. Variants 08 to 28 are classified as non-insulated.
3. The lead materials and finishes shall be in accordance with the requirements of ESCC Basic Specification No. [23500](#).
4. Available capacitance values and tolerances are as follows:
  - Tolerance:  $\pm 10\%$ ; value series: E12
  - Tolerance:  $\pm 20\%$ ; value series: E6

#### 1.5 MAXIMUM RATINGS

The maximum ratings shall not be exceeded at any time during use or storage.

Maximum ratings shall only be exceeded during testing to the extent specified in this specification and when stipulated in Test Methods and Procedures of the ESCC Generic Specification.

Characteristics	Symbols	Maximum Ratings	Units	Remarks
Rated Voltage	$U_R$	50, 100, 200, 500	V	Note 1
Operating Temperature Range	$T_{op}$	-55 to +125	$^{\circ}\text{C}$	Without derating. $T_{amb}$
Storage Temperature Range	$T_{stg}$	-55 to +125	$^{\circ}\text{C}$	
Soldering Temperature	$T_{sol}$	+260	$^{\circ}\text{C}$	Note 2

#### NOTES:

1. As required; See Component Type Variants and Range of Components.
2. Duration 10 seconds maximum and the same lead shall not be resoldered until 3 minutes have elapsed.

1.6 PHYSICAL DIMENSIONS

1.6.1 Variants 01 to 07 (lead type N)

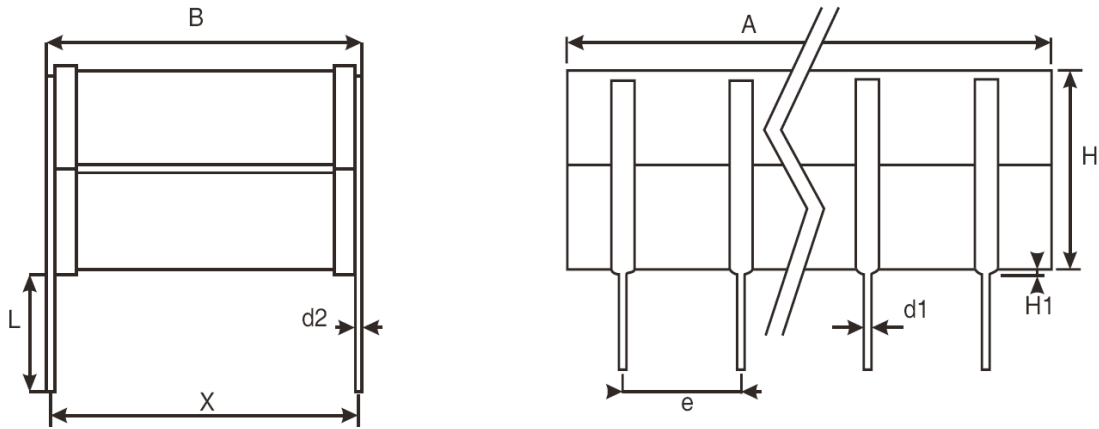

Variant Number	No. of Leads	Dimensions (mm)												
		A Max	B Max	d1 (Note 1)		d2 (Note 1)		e (Note 1)		H Max	H1 Max (Note 1)	L Min (Note 1)	X (Note 1)	
				Min	Max	Min	Max	Min	Max				Min	Max
01	6	8.7	9.2	0.4	0.6	0.2	0.3	2.49	2.59	Note 2	2.05	7.5	7.7	8.7
02	8	10.7	10.7	0.4	0.6	0.2	0.3	2.49	2.59	Note 2	2.05	7.5	9.66	10.66
03	10	13.6	14.9	0.4	0.6	0.2	0.3	2.49	2.59	Note 2	2.05	7.5	13.5	14.5
04	14	21.6	16.8	0.4	0.6	0.2	0.3	2.49	2.59	Note 2	2.05	7.5	14.74	15.74
05	28	38.2	12	0.4	0.6	0.2	0.3	2.49	2.59	Note 2	2.05	7.5	9.66	10.66
06	28	40.6	24	0.4	0.6	0.2	0.3	2.49	2.59	Note 2	2.05	7.5	19.82	20.82
07	12	16.6	21.6	0.4	0.6	0.2	0.3	2.49	2.59	Note 2	2.05	7.5	19.82	20.82

**NOTES:**

1. All leads.
2. See Component Type Variants and Range of Components for dimension H.

1.6.2 Variants 08 to 14 (lead type P)

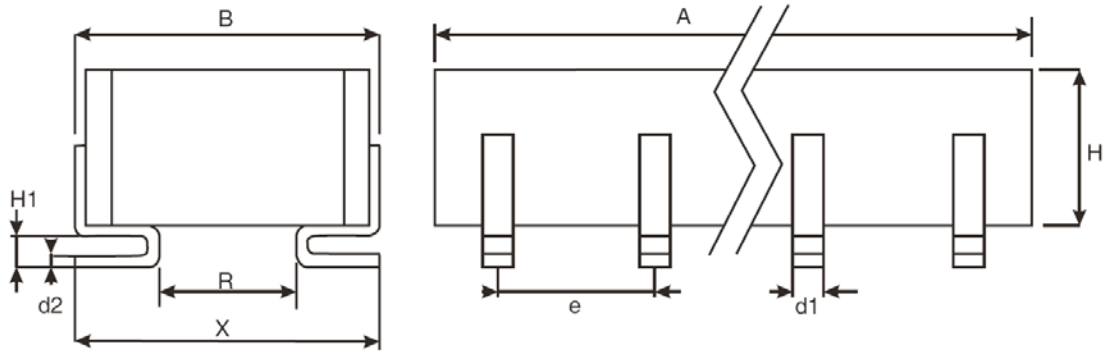

Variant Number	No. of Leads	Dimensions (mm)													
		A Max	B Max	d1 (Note 1)		d2 (Note 1)		e (Note 1)		H Max	H1 (Note 1)		R Min (Note 1)	X (Note 1)	
				Min	Max	Min	Max	Min	Max		Min	Max		Min	Max
08	6	8.7	9.2	0.4	0.6	0.2	0.3	2.49	2.59	Note 2	1.1	1.6	3.1	7.5	9
09	8	10.7	10.7	0.4	0.6	0.2	0.3	2.49	2.59	Note 2	1.1	1.6	4	9.5	12
10	10	13.6	14.9	0.4	0.6	0.2	0.3	2.49	2.59	Note 2	1.1	1.6	7.5	13.5	14.9
11	14	21.6	16.8	0.4	0.6	0.2	0.3	2.49	2.59	Note 2	1.1	1.6	10	14.5	16.8
12	28	38.2	12	0.4	0.6	0.2	0.3	2.49	2.59	Note 2	1.1	1.6	5.2	10	12
13	28	40.6	24	0.4	0.6	0.2	0.3	2.49	2.59	Note 2	1.1	1.6	16.1	20	24
14	12	16.6	21.6	0.4	0.6	0.2	0.3	2.49	2.59	Note 2	1.1	1.6	14.8	19	21.6

**NOTES:**

1. All leads.
2. See Component Type Variants and Range of Components for dimension H.

1.6.3 Variants 15 to 21 (lead type PL)

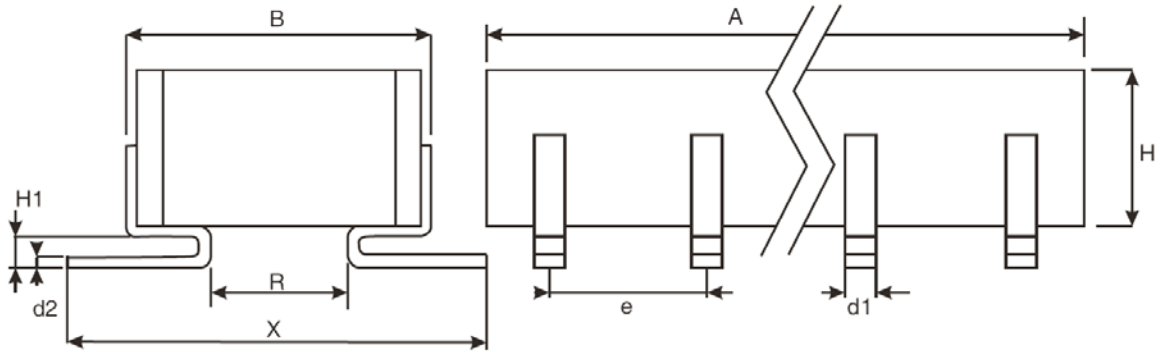

Variant Number	No. of Leads	Dimensions (mm)													
		A Max	B Max	d1 (Note 1)		d2 (Note 1)		e (Note 1)		H Max	H1 (Note 1)		R Min (Note 1)	X (Note 1)	
				Min	Max	Min	Max	Min	Max		Min	Max		Min	Max
15	6	8.7	9.2	0.4	0.6	0.2	0.3	2.49	2.59	Note 2	1.1	1.6	3.1	11.5	15
16	8	10.7	10.7	0.4	0.6	0.2	0.3	2.49	2.59	Note 2	1.1	1.6	4	13.5	18
17	10	13.6	14.9	0.4	0.6	0.2	0.3	2.49	2.59	Note 2	1.1	1.6	7.5	17.5	20.9
18	14	21.6	16.8	0.4	0.6	0.2	0.3	2.49	2.59	Note 2	1.1	1.6	10	18.5	22.8
19	28	38.2	12	0.4	0.6	0.2	0.3	2.49	2.59	Note 2	1.1	1.6	5.2	14	18
20	28	40.6	24	0.4	0.6	0.2	0.3	2.49	2.59	Note 2	1.1	1.6	16.1	24	30
21	12	16.6	21.6	0.4	0.6	0.2	0.3	2.49	2.59	Note 2	1.1	1.6	14.8	23	27.6

**NOTES:**

1. All leads.
2. See Component Type Variants and Range of Components for dimension H.

1.6.4 Variants 22 to 28 (lead type L)

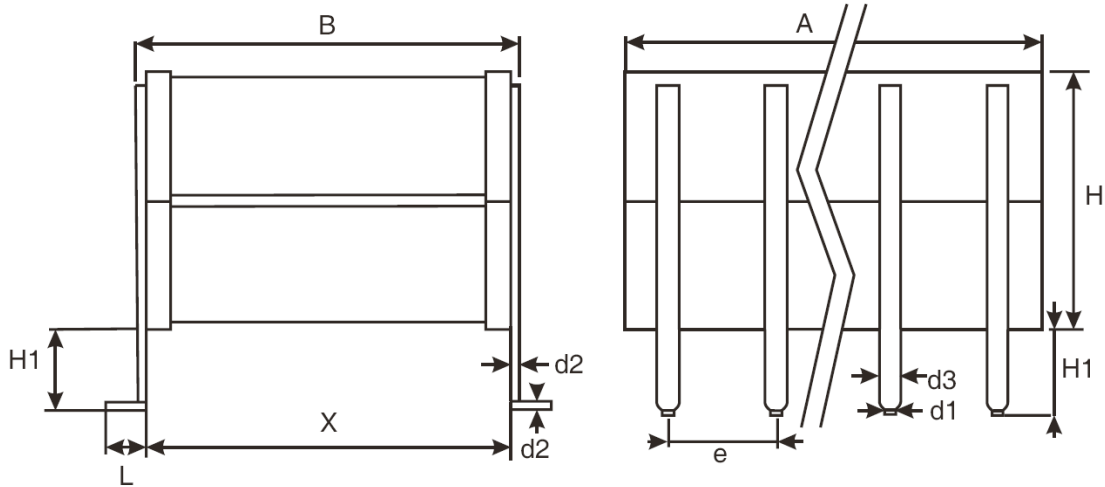

Variant Number	No. of Leads	Dimensions (mm)																	
		A Max	B Max	d1 (Note 1)		d2 (Note 1)		d3 (Note 1)		e (Note 1)		H Max	H1 (Note 1)		L (Note 1)		X (Note 1)		
				Min	Max	Min	Max	Min	Max	Min	Max		Min	Max	Min	Max	Min	Max	
22	6	8.7	9.2	0.4	0.6	0.2	0.3	0.9	1.1	2.49	2.59	Note 2	2	3	2	3	6.7	8.7	
23	8	10.7	10.7	0.4	0.6	0.2	0.3	0.9	1.1	2.49	2.59	Note 2	2	3	2	3	8.2	10	
24	10	13.6	14.9	0.4	0.6	0.2	0.3	0.9	1.1	2.49	2.59	Note 2	2	3	2	3	12.4	14.4	
25	14	21.6	16.8	0.4	0.6	0.2	0.3	0.9	1.1	2.49	2.59	Note 2	2	3	2	3	14.3	16.3	
26	28	38.2	12	0.4	0.6	0.2	0.3	0.9	1.1	2.49	2.59	Note 2	2	3	2	3	9.5	11.5	
27	28	40.6	24	0.4	0.6	0.2	0.3	0.9	1.1	2.49	2.59	Note 2	2	3	2	3	21.5	23.5	
28	12	16.6	21.6	0.4	0.6	0.2	0.3	0.9	1.1	2.49	2.59	Note 2	2	3	2	3	19.5	21.1	

**NOTES:**

1. All leads.
2. See Component Type Variants and Range of Components for dimension H.

1.7 FUNCTIONAL DIAGRAM



**NOTES:**

1. All leads on each side of the component are connected to the same capacitor terminal.

## 2 REQUIREMENTS

### 2.1 GENERAL

The complete requirements for procurement of the components specified herein are as stated in this specification and the ESCC Generic Specification. Permitted deviations from the Generic Specification, applicable to this specification only, are listed below.

Permitted deviations from the Generic Specification and this Detail Specification, formally agreed with specific Manufacturers on the basis that the alternative requirements are equivalent to the ESCC requirement and do not affect the component's reliability, are listed in the appendices attached to this specification.

#### 2.1.1 Deviations from the Generic Specification

##### 2.1.1.1 *Deviations from Qualification and Periodic Tests (Chart F4)*

- (a) Resistance to Soldering Heat and Solderability:
  - For Variants 01 to 07: Immersion depth shall be between 2mm and 2.5mm from the body.
  - For Variants 08 to 28: Only the part of the leads designed to be soldered shall be tested.
- (b) Vibration: Prior to Vibration, the samples shall be mounted and glued on to a suitable substrate in order to avoid any stress. The samples shall be maintained on the substrate for all subsequent tests in the subgroup test sequence.

### 2.2 MARKING

The marking shall be in accordance with the requirements of ESCC Basic Specification No. [21700](#) and as follows.

The information to be marked on the component shall be:

- (a) The ESCC qualified components symbol (for ESCC qualified components only).
- (b) The ESCC Component Number.
- (c) Traceability information.

### 2.3 ROBUSTNESS OF TERMINATIONS

The terminations of these devices are classified as rigid. The test conditions for Robustness of Terminations shall be as specified in the ESCC Generic Specification and as follows:

For Variants 01 to 07:

- Applicable test: Ua1 (tensile) only.
- Terminations tested: a minimum of one randomly selected lead on each side of the component.
- Applied force: 5N

For Variants 08 to 28:

- Applicable test: Ue3 (shear) only.
- Pushing force: 10N for 10s

2.4 ELECTRICAL MEASUREMENTS AT ROOM, HIGH AND LOW TEMPERATURES

Electrical measurements shall be performed at room, high and low temperatures.

2.4.1 Room Temperature Electrical Measurements

The measurements shall be performed at  $T_{amb} = +22 \pm 3^{\circ}C$ .

Characteristics	Symbols	Test Method and Conditions	Tolerance ( $\pm$ %)	Limits		Units
				Min	Max	
Capacitance (Note 1)	$C_A$	ESCC No. 3001	10 20	$0.9C_n$ $0.8C_n$	$1.1C_n$ $1.2C_n$	$\mu F$
Tangent of Loss Angle	$tg\delta$	ESCC No. 3001	All	-	$250 \times 10^{-4}$	-
Insulation Resistance (Dielectric)	$R_{ID}$	ESCC No. 3001	All	1000	-	$G\Omega.nF$
Insulation Resistance (Body Insulation)	$R_{IB}$	ESCC No. 3001 Variants 01 to 07 only Note 2	All	1000	-	$G\Omega.nF$
Voltage Proof (Dielectric)	$VP_D$	ESCC No. 3001 $U_R < 500V$ $U_R = 500V$	All	$2.5U_R$ $2U_R$	- -	V
Voltage Proof (Body Insulation)	$VP_B$	ESCC No. 3001 Variants 01 to 07 only Note 2 $U_R < 500V$ $U_R = 500V$	All	$2.5U_R$ $2U_R$	- -	V

**NOTES:**

1. Capacitance limits may be adjusted to take into account capacitance ageing, as specified in the Generic Specification.
2. The measurements shall be performed on a sample of 5 components from each manufacturing lot with 0 failures allowed. In the event of any failure a 100% inspection may be performed. In the case of a 100% inspection, a 1% total percent defective is allowed.



2.4.2 High and Low Temperatures Electrical Measurements

Characteristics	Symbols	Test Method and Conditions (Note 1)	Limits		Units
			Min	Max	
Temperature Characteristic	TC	ESCC No. 3001 T <sub>amb</sub> = -55 ±2°C, +20 ±2°C, +125 ±2°C Note 2 For V <sub>T</sub> = no voltage applied For V <sub>T</sub> = U <sub>R</sub> (Note 3)	-20 -50	+20 +30	%

**NOTES:**

1. The measurements shall be performed on a sample of 5 components from each manufacturing lot with 0 failures allowed. In the event of any failure a 100% inspection may be performed.
2. In the case of a 100% inspection, a 1% total percent defective is allowed.
3. V<sub>T</sub> = 200V for all U<sub>R</sub> = 500V components.

2.5 INTERMEDIATE AND END-POINT ELECTRICAL MEASUREMENTS

Unless otherwise specified, the measurements shall be performed at T<sub>amb</sub> = +22 ±3°C.

Unless otherwise specified the test methods and test conditions shall be as per the corresponding test defined in Room Temperature Electrical Measurements.

Test Reference per ESCC No. 3001	Characteristics	Symbols	Limits		Units	
			Min	Max		
Rapid Change of Temperature Initial Measurements Final Measurements	Capacitance	C <sub>A</sub>	Note 1		%	
	Capacitance	C <sub>A</sub>	Note 1			
	Change in Capacitance	ΔC <sub>A</sub> /C <sub>A</sub>	-15	+15		
	Tangent of Loss Angle	tgδ	-	250 ×10 <sup>-4</sup>		
Steady State Humidity Initial Measurements Final Measurements	Capacitance	C <sub>A</sub>	Note 1		%	
	Capacitance	C <sub>A</sub>	Note 1			
	Change in Capacitance	ΔC <sub>A</sub> /C <sub>A</sub>	-10	+10		
	Tangent of Loss Angle	tgδ	-	250 ×10 <sup>-4</sup>		
	Insulation Resistance (Dielectric) (Note 2)	R <sub>ID</sub>	30	-		GΩ.nF
	Insulation Resistance (Body Insulation) (Notes 2, 3)	R <sub>IB</sub>	30	-		GΩ.nF

Test Reference per ESCC No. 3001	Characteristics	Symbols	Limits		Units
			Min	Max	
Operating Life					
Initial Measurements	Capacitance	$C_A$	Note 1		
Intermediate Measurements (1000 hours) (Note 4)	Capacitance	$C_A$	Note 1		
	Change in Capacitance	$\Delta C_A/C_A$	-15	+15	%
	Insulation Resistance (Dielectric) (Note 2)	$R_{ID}$	100	-	GΩ.nF
	Insulation Resistance (Body Insulation) (Notes 2, 3)	$R_{IB}$	100	-	GΩ.nF
Final Measurements (1000 or 2000 hours) (Note 5)	Capacitance	$C_A$	Note 1		
	Change in Capacitance	$\Delta C_A/C_A$	-20	+20	%
	Tangent of Loss Angle	$tg\delta$	-	$250 \times 10^{-4}$	-
	Insulation Resistance (Dielectric) (Note 2)	$R_{ID}$	100	-	MΩ.μF
	Insulation Resistance (Body Insulation) (Notes 2, 3)	$R_{IB}$	100	-	MΩ.μF
	Voltage Proof (Dielectric)	$VP_D$	Note 1		
	Voltage Proof (Body Insulation) (Note 2)	$VP_B$	Note 1		
	Capacitance-Temperature Characteristics	Temperature Characteristic	TC	Note 6	
Resistance to Soldering Heat					
Initial Measurements	Capacitance	$C_A$	Note 1		
Final Measurements	Capacitance	$C_A$	Note 1		
	Change in Capacitance	$\Delta C_A/C_A$	-15	+15	%
	Insulation Resistance (Dielectric) (Note 2)	$R_{ID}$	1000	-	GΩ.nF
	Insulation Resistance (Body Insulation) (Notes 2, 3)	$R_{IB}$	1000	-	GΩ.nF

**NOTES:**

1. As specified in Room Temperature Electrical Measurements.
2. Test conditions for Insulation Resistance shall be as specified in Steady State Humidity in the ESCC Generic Specification.
3. Variants 01 to 07 only.
4. Intermediate measurements are optional at the Manufacturer's discretion.
5. 1000 hours is applicable to Periodic Testing for extension of qualification. 2000 hours is applicable to Qualification Testing, and to Periodic Testing for renewal of qualification after lapse.
6. As specified in High and Low Temperatures Electrical Measurements.

## 2.6 BURN-IN

The requirements for Burn-in are specified in the ESCC Generic Specification. The following conditions shall also apply:

- After Burn-in, the components shall be removed from the chamber and allowed to cool under normal atmospheric conditions for recovery for 24 hours minimum.

**APPENDIX A****AGREED DEVIATIONS FOR EXXELIA TECHNOLOGIES (F)**

Items Affected	Description of Deviations
Deviations from Generic Specification: Special In-Process Controls (Chart F2)	Robustness of Terminations shall not be performed.