



Pages 1 to 24

## **DIODES, MICROWAVE, SILICON, PIN, ULTRA FAST SWITCHING**

**BASED ON TYPES DH50071 to DH50077**

**ESCC Detail Specification No. 5513/037**

Issue 4	November 2010
---------	---------------



Document Custodian: European Space Agency - see <https://escies.org>

### **LEGAL DISCLAIMER AND COPYRIGHT**

European Space Agency, Copyright © 2010. All rights reserved.

The European Space Agency disclaims any liability or responsibility, to any person or entity, with respect to any loss or damage caused, or alleged to be caused, directly or indirectly by the use and application of this ESCC publication.

This publication, without the prior permission of the European Space Agency and provided that it is not used for a commercial purpose, may be:

- copied in whole, in any medium, without alteration or modification.
- copied in part, in any medium, provided that the ESCC document identification, comprising the ESCC symbol, document number and document issue, is removed.

**DOCUMENTATION CHANGE NOTICE**

(Refer to <https://escies.org> for ESCC DCR content)

DCR No.	CHANGE DESCRIPTION
192, 622	Specification updated to incorporate editorial and technical changes per DCR.

**TABLE OF CONTENTS**

**1. GENERAL ..... 6**

1.1 SCOPE ..... 6

1.2 COMPONENT TYPE VARIANTS ..... 6

1.3 MAXIMUM RATINGS ..... 6

1.4 PARAMETERS DERATING INFORMATION ..... 6

1.5 PHYSICAL DIMENSIONS ..... 6

1.6 FUNCTIONAL DIAGRAM ..... 6

1.7 HANDLING PRECAUTIONS ..... 6

**2. APPLICABLE DOCUMENTS ..... 6**

**3. TERMS, DEFINITIONS, ABBREVIATIONS, SYMBOLS AND UNITS ..... 6**

**4. REQUIREMENTS ..... 16**

4.1 GENERAL ..... 16

4.2 DEVIATIONS FROM GENERIC SPECIFICATION ..... 16

4.2.1 *Deviations from Special In-process Controls* ..... 16

4.2.2 *Deviations from Final Production Tests (Chart II)* ..... 16

4.2.3 *Deviations from Burn-in and Electrical Measurements (Chart III)* ..... 16

4.2.4 *Deviations from Qualification Tests (Chart IV)* ..... 16

4.2.5 *Deviations from Lot Acceptance Tests (Chart V)* ..... 16

4.3 MECHANICAL AND ENVIRONMENTAL REQUIREMENTS ..... 16

4.3.1 *Dimension Check* ..... 16

4.3.2 *Weight* ..... 16

4.3.3 *Terminal Strength* ..... 17

4.3.1 *Bond Strength* ..... 17

4.3.2 *Die Shear* ..... 17

4.3.1 *High Temperature Stabilisation Bake* ..... 17

4.4 MATERIAL AND FINISHES ..... 17

4.4.1 *Case* ..... 17

4.4.2 *Lead Material and Finish* ..... 17

4.5 MARKING ..... 17

4.5.1 *General* ..... 17

4.5.2 *Cathode Identification* ..... 18

4.5.3 *The ESCC Component Number* ..... 18

4.5.4 *Traceability Information* ..... 18

4.6 ELECTRICAL MEASUREMENTS ..... 18

4.6.1 *Electrical Measurements at Room Temperature* ..... 18

4.6.2 *Electrical Measurements at High and Low Temperatures* ..... 18

4.6.3 *Circuits for Electrical Measurements* ..... 18

4.7 BURN-IN TESTS ..... 18

4.7.1 *Parameter Drift Values* ..... 18

4.7.2 *Conditions for High Temperature Reverse Bias Burn-in* ..... 18

4.7.3 *Conditions for Power Burn-in* ..... 18

4.7.4 *Electrical Circuits for High Temperature Reverse Bias and Power Burn-in* ..... 18

4.8 ENVIRONMENTAL AND ENDURANCE TESTS (CHARTS IV AND V OF ESCC GENERIC SPECIFICATION NO. 5010) ..... 22

4.8.1 *Electrical Measurements on Completion of Environmental Tests* ..... 22

4.8.2 *Electrical Measurements at Intermediate Points and on Completion of Endurance Tests* ..... 22

4.8.3 *Conditions for Operating Life Tests (Part of Endurance Testing)* ..... 22

4.8.4 *Electrical Circuits for Operating Life Tests* ..... 22

4.9 TOTAL DOSE IRRADIATION TESTING ..... 22

4.10 SPECIAL TESTING ..... 22

**TABLES**

1(a)	Type Variants	7
1(b)	Maximum Ratings	9
2(a)	Electrical Measurements at Room Temperature – D.C. Parameters	19
2(b)	Electrical Measurements at Room Temperature – A.C. Parameters	19
3	Electrical Measurements at High and Low Temperatures	19
4	Parameter drift Values	20
5(a)	Conditions for High Temperature Reverse Bias Burn-In	21
5(b)	Conditions for Power Burn-In and Operating Life Tests	21
6	Electrical Measurements at Intermediate Points and on Completion of Endurance Testing	23
7	Electrical Measurements During and on Completion of Irradiation Testing	23

**FIGURES**

1	Parameter Derating Information	10
2	Physical Dimensions	11
3	Functional Diagram	15
4	Circuits for Electrical Measurements	20
5(a)	Electrical circuit for High Temperature Reverse Bias Burn-in	21
5(b)	Electrical Circuit for Power Burn-in and Operating Life Tests	22
6	Bias Conditions for Irradiation Testing	23

**APPENDICES (APPLICABLE TO SPECIFIC MANUFACTURERS ONLY)**

'A'	Agreed Deviations for COBHAM MICROWAVE (F)	24
-----	--	----

## 1. **GENERAL**

### 1.1 Scope

This specification details the ratings, physical and electrical characteristics, test and inspection data for a Microwave Silicon PIN Ultra-Fast Switching Diode, based on Types DH50071 to DH50077. It shall be read in conjunction with ESCC Generic Specification No. 5010, the requirements of which are supplemented herein.

### 1.2 Component type variants

Variants of the basic diodes specified herein, which are also covered by this specification are given in Table 1(a).

### 1.3 Maximum ratings

The maximum ratings, which shall not be exceeded at any time during use or storage, applicable to the diodes specified herein, are as scheduled in Table 1(b).

### 1.4 Parameters derating information

The derating information applicable to the diodes specified herein is shown in Figure 1.

### 1.5 Physical dimensions

The physical dimensions of the diodes specified herein are shown in Figure 2.

### 1.6 Functional diagram

The functional diagram, showing lead identification, of the diodes specified herein, is shown in Figure 3.

### 1.7 Handling precautions

These devices are susceptible to be damaged by electrostatic discharge. Therefore, suitable precautions shall be employed for protection during all phases of manufacture, testing, packaging, shipment and any handling.

The components are categorised as Class 1 with a Minimum Critical Path Failure Voltage ( MCPFV ) of 500V.

## 2. **APPLICABLE DOCUMENTS**

The following documents form part of this specification and shall be read in conjunction with it :

- (a) ESCC Generic Specification No. 5010 for Discrete Microwave Semiconductor Components.
- (b) MIL-STD-750, Test Methods for Semiconductor Devices.

## 3. **TERMS, DEFINITIONS, ABBREVIATIONS, SYMBOLS AND UNITS**

For the purpose of this specification, the terms, definitions, abbreviations, symbols and units specified in ESCC Basic Specification No. 21300 shall apply. In addition the following symbols are used :

$C_T$  = Total Capacitance.

**TABLE 1(a) – TYPE VARIANTS**

(1) VARIANT	(2) BASED ON TYPE	(3) FIGURE	(4) TOTAL CAPACITANCE C <sub>T</sub> (pF) (Note 1) MAX	(5) FORWARD SERIES RESISTANCE R <sub>SF</sub> (Ω) MAX	(6) MINORITY CARRIER LIFETIME τ <sub>L</sub> (ns) MAX	(7) BODY-LID AND/OR LEAD MATERIAL AND FINISH
01	DH50071	2 (a)	0.19	2.0	100	D7 - E2
02		2 (b)				D7
03		2 (c)				D7 - E2
04		2 (d)				
05		2 (e)				
06		2 (f)				
07		2 (g)	0.26			A7 - D7
50		2 (h)	0.20			D7
08	DH50072	2 (a)	0.21	1.7	100	D7 - E2
09		2 (b)				D7
10		2 (c)				D7 - E2
11		2 (d)				
12		2 (e)				
13		2 (f)				
14		2 (g)	0.28			A7 - D7
51		2 (h)	0.22			D7
15	DH50073	2 (a)	0.25	1.6	120	D7 - E2
16		2 (b)				D7
17		2 (c)				D7 - E2
18		2 (d)				
19		2 (e)				
20		2 (f)				
21		2 (g)	0.32			A7 - D7
52		2 (h)	0.26			D7
22	DH50074	2 (a)	0.30	1.4	120	D7 - E2
23		2 (b)				D7
24		2 (c)				D7 - E2
25		2 (d)				
26		2 (e)				
27		2 (f)				
28		2 (g)	0.37			A7 - D7
53		2 (h)	0.31			D7

**NOTES**

1. V<sub>R</sub> = - 6.0V, f = 1.0MHz

**TABLE 1(a) – TYPE VARIANTS (CONTINUED)**

(1) VARIANT	(2) BASED ON TYPE	(3) FIGURE	(4) TOTAL CAPACITANCE C <sub>T</sub> (pF) (Note 1) MAX	(5) FORWARD SERIES RESISTANCE R <sub>SF</sub> (Ω) MAX	(6) MINORITY CARRIER LIFETIME τ <sub>L</sub> (ns) MAX	(7) BODY-LID AND/OR LEAD MATERIAL AND FINISH
29	DH50075	2 (a)	0.36	1.0	200	D7 - E2
30		2 (b)				D7
31		2 (c)				D7 - E2
32		2 (d)				
33		2 (e)				
34		2 (f)				
35		2 (g)	0.43			A7 - D7
54		2 (h)	0.37			D7
36	DH50076	2 (a)	0.53	0.9	200	D7 - E2
37		2 (b)				D7
38		2 (c)				D7 - E2
39		2 (d)				
40		2 (e)				
41		2 (f)				
42		2 (g)	0.60			A7 - D7
55		2 (h)	0.54			D7
43	DH50077	2 (a)	0.73	0.7	300	D7 - E2
44		2 (b)				D7
45		2 (c)				D7 - E2
46		2 (d)				
47		2 (e)				
48		2 (f)				
49		2 (g)	0.80			A7 - D7
56		2 (h)	0.74			D7

**NOTES**

1. V<sub>R</sub> = - 6.0V, f = 1.0MHz



**TABLE 1(b) - MAXIMUM RATINGS**

No.	CHARACTERISTIC	SYMBOL	MAXIMUM RATINGS	UNIT	REMARKS
1	D.C. Reverse Voltage	$V_R$	-70	V	$I_R = 10 \mu A$
2	D.C. Forward Current (Continuous) Variants 50 to 56 Variants 01 to 06, 08 to 13 and 15 to 20, Variants 22 to 27, 29 to 34 and 36 to 41 Variant 07 and 43 to 48 Variants 43 to 48 Variants 14, 21, 28, 35 and 42 Variant 49	$I_F$	90 150 150 180 240 300	mA	Note 1
3	R.F. Power Dissipation Variants 50 to 56 Variants 01 to 06, 08 to 13 and 15 to 20, Variants 22 to 27, 29 to 34 and 36 to 41 Variant 07 and 43 to 48 Variants 14, 21, 28, 35 and 42 Variant 49	$P_{tot}$	0.30 0.50 0.50 0.62 0.83 1.25	W	Note 1
4	Thermal Resistance (Junction to Case) Variants 50 to 56 Variants 01 to 06, 08 to 13 and 15 to 20, Variants 22 to 27, 29 to 34 and 36 to 41 Variant 07 and 43 to 48 Variants 14, 21, 28, 35 and 42 Variant 49	$R_{TH(J-C)}$	250 150 150 120 90 60	°C/W	-
5	Operating Temperature Range	$T_{op}$	-55 to +150	°C	$T_{case}$
6	Storage Temperature Range	$T_{stg}$	-65 to +175	°C	-
7	Soldering Temperature	$T_{sol}$	+ 230	°C	Note 2

**NOTES**

1. At  $T_{case} = + 75^\circ C$ . For derating at  $T_{case} > + 75^\circ C$ , see Figure 1.
2. Duration 5 seconds maximum and the same termination shall not be resoldered until 3 minutes have elapsed.

**FIGURE 1 - PARAMETER DERATING INFORMATION**

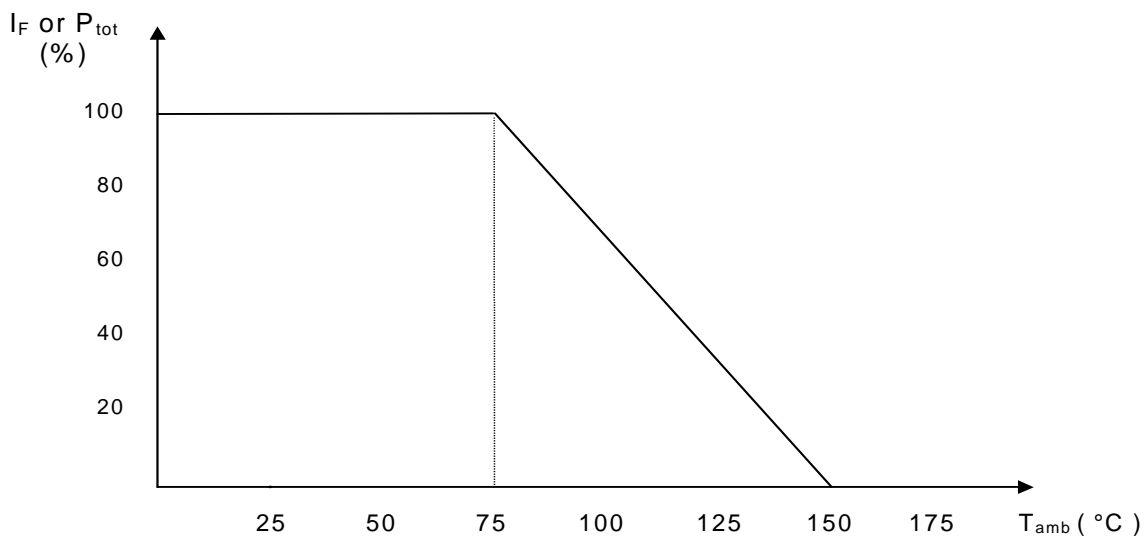

Forward Current or Power Dissipation versus Temperature

**FIGURE 2 - PHYSICAL DIMENSIONS**

FIGURE 2(a) – Variants 01, 08, 15, 22, 29, 36, 43

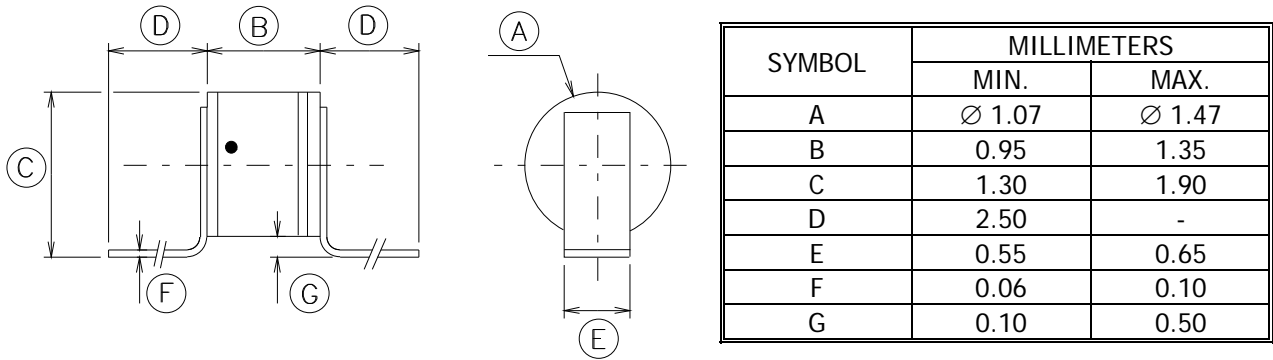
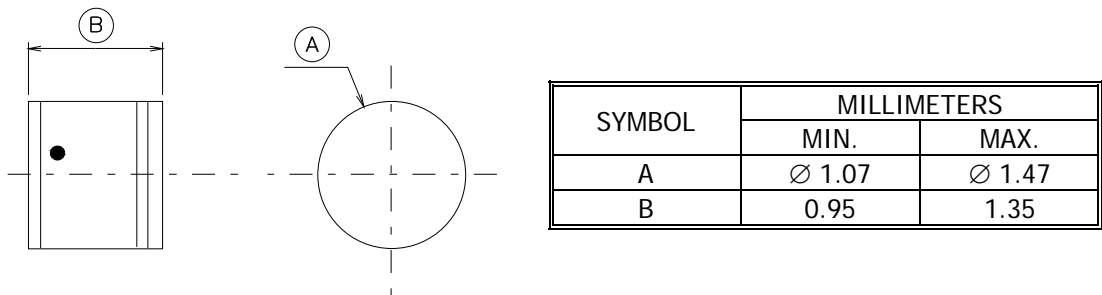

FIGURE 2(b) – Variants 02, 09, 16, 23, 30, 37, 44



**FIGURE 2 - PHYSICAL DIMENSIONS ( CONTINUED)**

FIGURE 2(c) – Variants 03, 10, 17, 24, 31, 38, 45

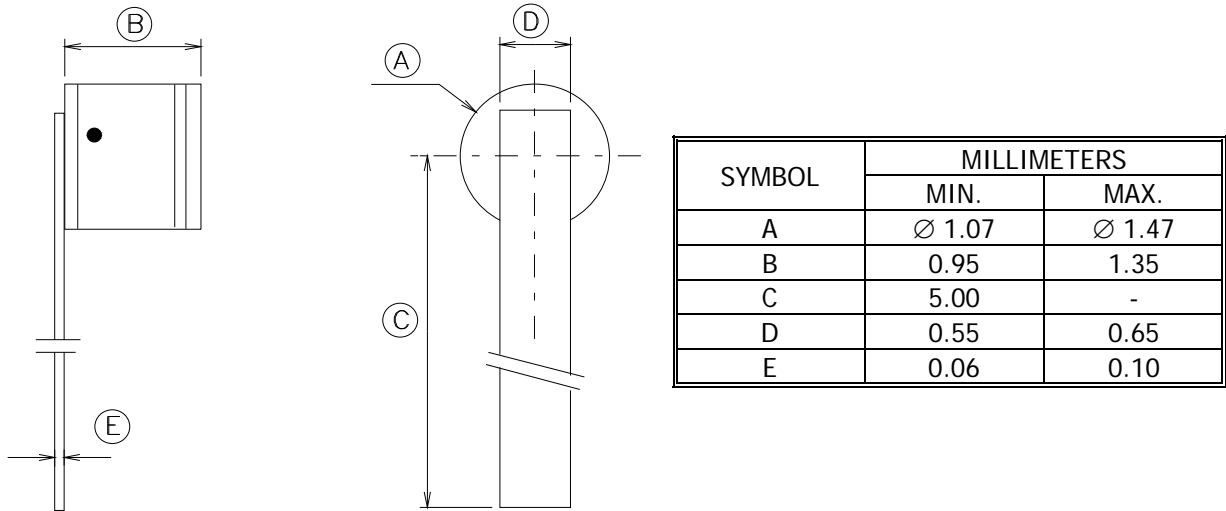
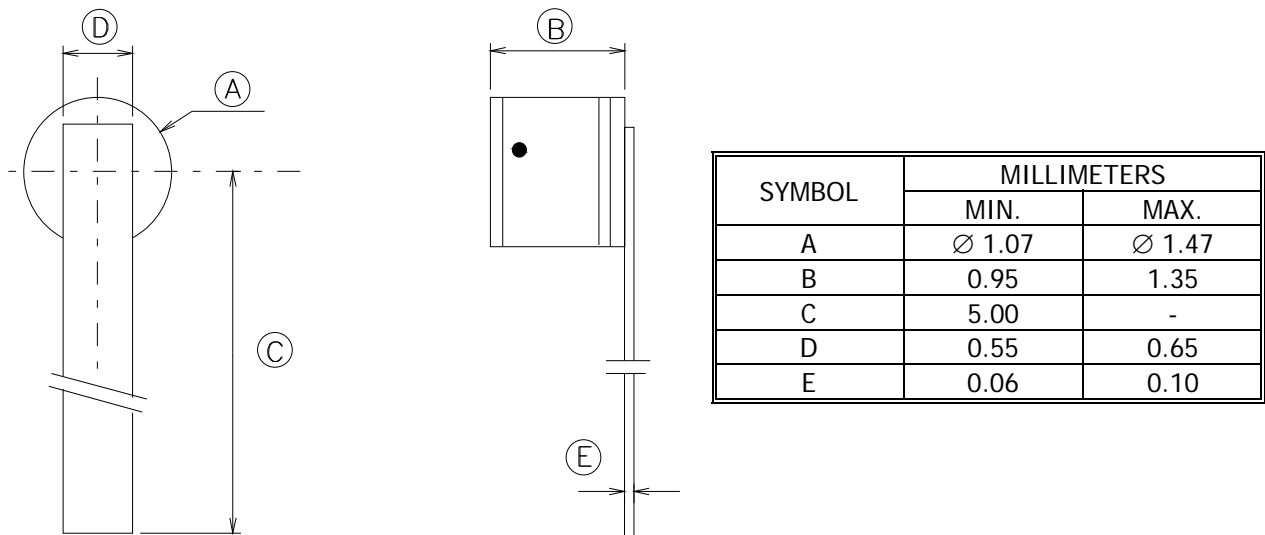

FIGURE 2(d) – Variants 04, 11, 18, 25, 32, 39, 46



**FIGURE 2 - PHYSICAL DIMENSIONS ( CONTINUED)**

FIGURE 2(e) – Variants 05, 12, 19, 26, 33, 40, 47

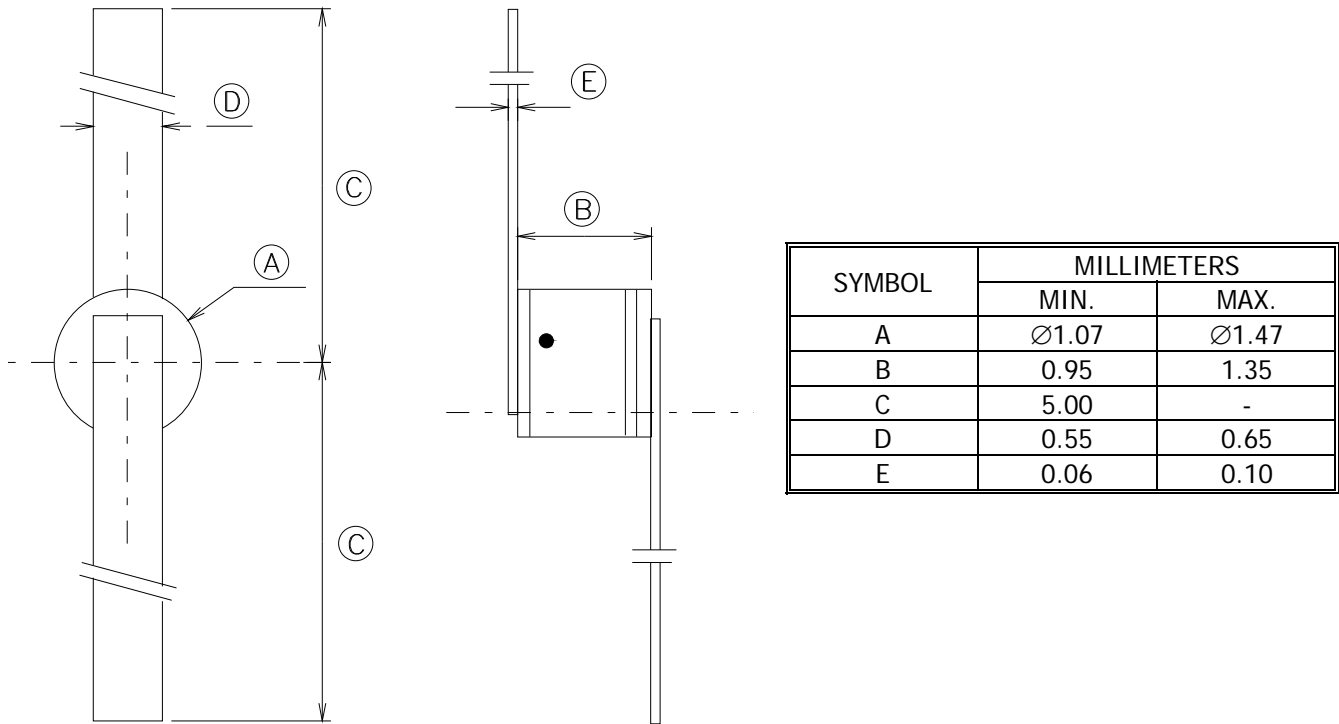
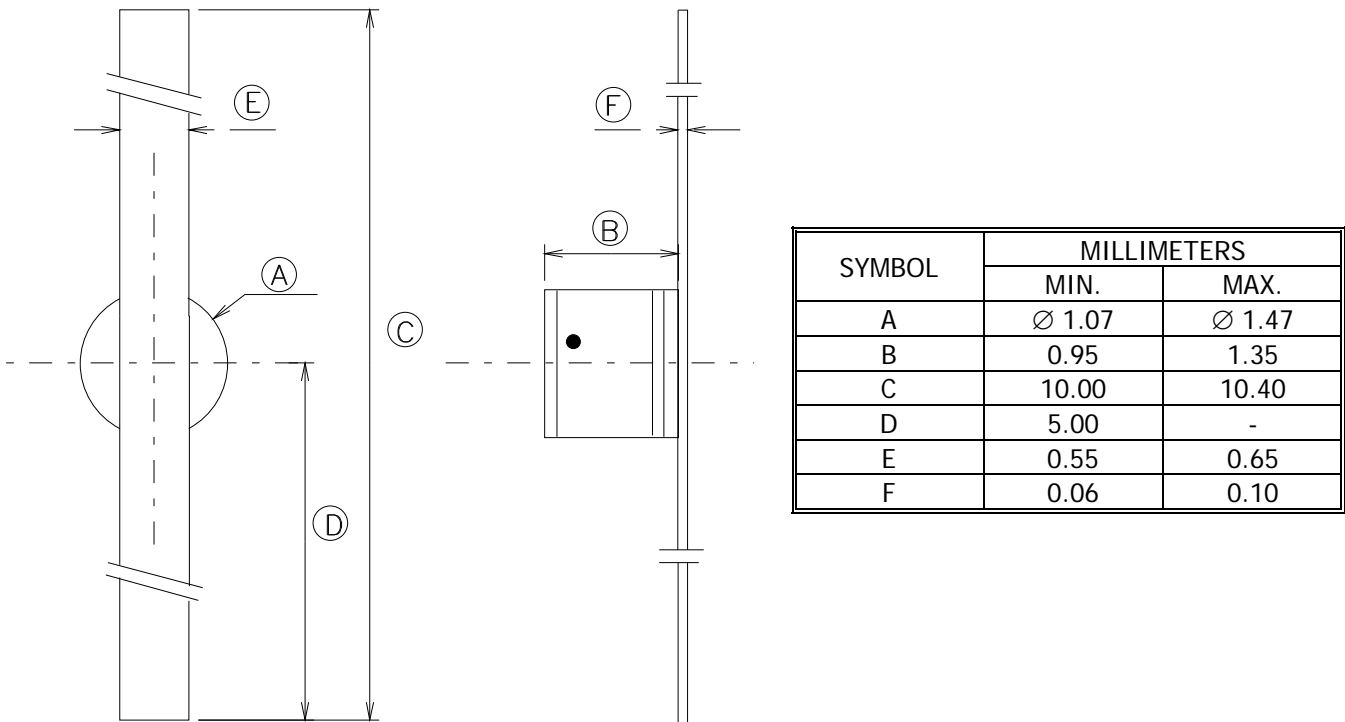
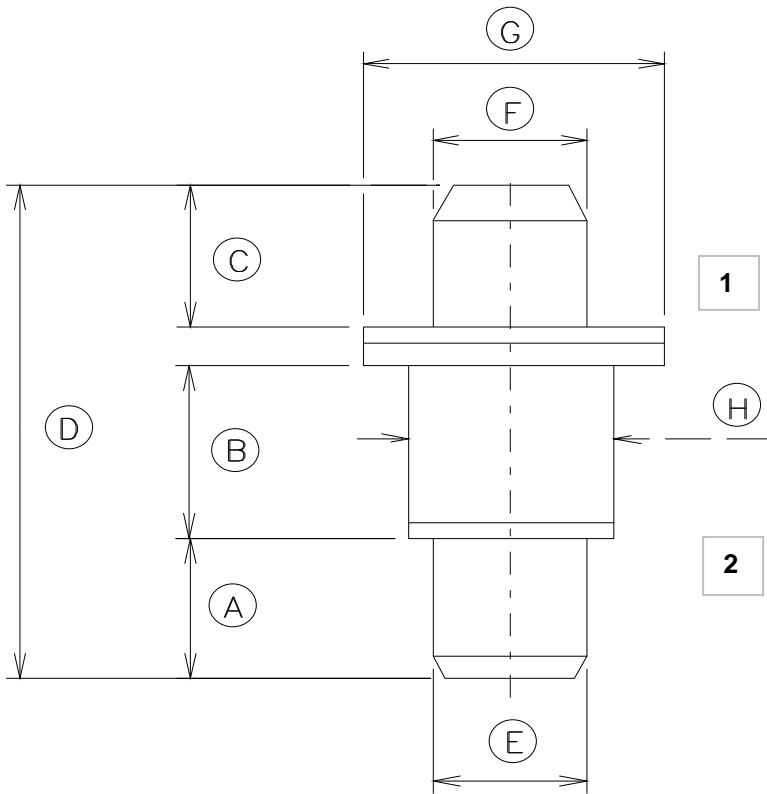

FIGURE 2(f) – Variants 06, 13, 20, 27, 34, 41, 48



**FIGURE 2 - PHYSICAL DIMENSIONS ( CONTINUED)**

FIGURE 2(g) – Variants 07, 14, 21, 28, 35, 42, 49



SYMBOL	MILLIMETERS	
	MIN.	MAX.
A	1.52	1.63
B	1.75	1.85
C	1.52	1.63
D	5.20	5.72
E	∅ 1.52	∅ 1.63
F	∅ 1.52	∅ 1.63
G	∅ 3.00	∅ 3.23
H	∅ 1.95	∅ 2.11

**FIGURE 2 - PHYSICAL DIMENSIONS ( CONTINUED)**

FIGURE 2(h) – Variants 50 to 56

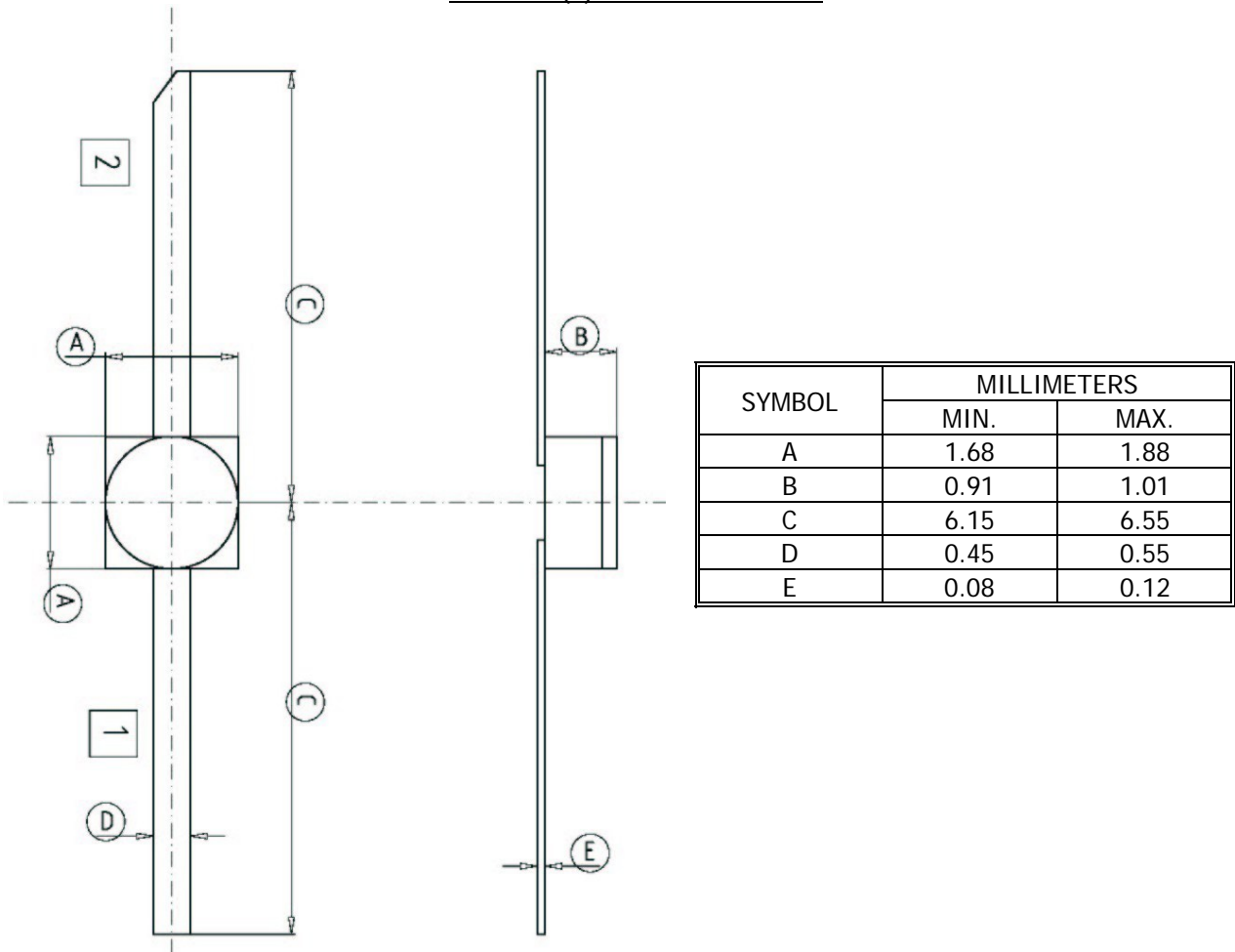

**FIGURE 3 - FUNCTIONAL DIAGRAM**

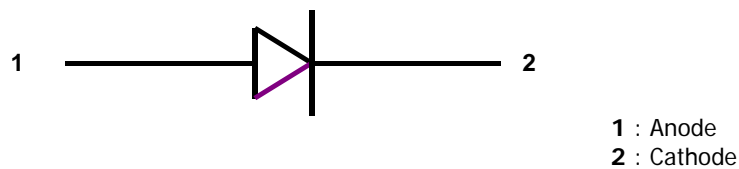

**NOTES**

- For variants 01 to 06, 08 to 13, 15 to 20, 22 to 27, 29 to 34, 36 to 41 and 43 to 48: The cathode end shall be marked with a black dot. The marking will not be on the cathode connection but adjacent to it as shown in Figures 2(a) to 2(f).
- For variants 07, 14, 21, 28, 35, 42 and 49 terminal identification shall be by means of the physical configuration of the package as shown in Figure 2(g).
- For variants 50 to 56 the cathode end shall be indicated by a 45° chamfer to the lead end as shown in Figure 2(h).

## 4. **REQUIREMENTS**

### 4.1 General

The complete requirements for procurement of the diodes specified herein shall be as stated in this specification and ESCC Generic Specification No. 5010 for Discrete Microwave Semiconductor Components. Deviations from the Generic Specification applicable to this specification only, are listed in Para. 4.2.

Deviations from the applicable Generic Specification and this Detail Specification, formally agreed with specific Manufacturers on the basis that the alternative requirements are equivalent to the ESCC requirements and do not affect the components' reliability, are listed in the appendices attached to this specification.

### 4.2 Deviations from generic specification

#### 4.2.1 Deviations from Special In-process Controls

- (a) Para. 5.2, Wafer Lot Acceptance : S.E.M. inspection shall be performed on 3 dice, after die separation.
- (b) Para. 5.3, Wafer Screening (Chart II(a)) : Minority Carrier Lifetime shall be performed as an on-wafer measurement on a sample of 27 dice per wafer.

#### 4.2.2 Deviations from Final Production Tests (Chart II(b))

- (a) Para. 6.3, Pre-burn-in : Shall be performed in accordance with Para. 9.21(a) using the conditions specified in Table 5(a) of this specification for a duration of 48 hours minimum.
- (b) Para 9.2.2, Die Shear : Individual forces need not be recorded and the minimum residual die area shall be  $\geq 50\%$  of the original die size.

#### 4.2.3 Deviations from Burn-in and Electrical Measurements (Chart III(a))

- (a) Para. 9.21, High Temperature Reverse Bias Burn-in : Shall be performed at 75% of rated  $V_R$ .

#### 4.2.4 Deviations from Qualification Tests (Chart IV)

- (a) Para. 9.2.4, Die-Shear : Individual forces need not be recorded and the minimum residual die area shall be  $\geq 50\%$  of the original die size.
- (b) Para. 9.14, Vibration Test : Shall not be performed.
- (c) Para. 9.15, Constant Acceleration : Shall not be performed.
- (d) Para. 9.23, Special Testing : Shall not be performed.

#### 4.2.5 Deviations from Lot Acceptance Tests (Chart V)

- (a) Para. 9.14, Vibration : Shall not be performed.
- (b) Para. 9.15, Constant Acceleration : Shall not be performed.
- (c) Para. 9.23, Special Testing : Shall not be performed.

### 4.3 Mechanical and environmental requirements

#### 4.3.1 Dimension Check

The dimensions of the diodes specified herein shall be checked. They shall conform to those shown in Figure 2.

#### 4.3.2 Weight

The maximum weight of the diodes specified herein shall be as follows :

- Variants 01 to 06, 08 to 13, 15 to 20, 22 to 27, 29 to 34, 36 to 41, 43 to 48 and 50 to 56 : 0.02g.
- Variants 07, 14, 21, 28, 35, 42 and 49 : 0.15g



#### 4.3.3 Terminal Strength

The requirements for terminal strength are specified in Section 9 of ESCC Generic Specification No. 5010. The test conditions shall be as follows :

(a) Condition : 'A' (tension).

Variants 01, 03 to 06, 08, 10 to 13, 15, 17 to 20, 22, 24 to 27, 29, 31 to 34, 36, 38 to 41, 43, 45 to 48 and 50 to 56:

- Force : 1.25 N
- Duration : 10 seconds

#### 4.3.4 Bond Strength

The requirements for bond strength are specified in Section 9 of ESCC Generic Specification No. 5010. The test conditions shall be as follows :

- (a) Condition : 'A' (tension).
- (b) Separating Force : 0.03N minimum.

#### 4.3.5 Die Shear

The requirements for die shear are specified in Section 9 of ESCC Generic Specification No. 5010. The test conditions shall be as follows :

- (a) Semiconductor material remaining : 50% minimum.

#### 4.3.6 High Temperature Stabilisation Bake

The requirements for high temperature stabilisation bake are specified in Section 9 of ESCC Generic Specification No. 5010. The temperature to be applied shall be + 175 (+0 -3)°C.

### 4.4 Materials and finishes

The materials and finishes shall be as specified herein. Where a definite material is not specified, a material which will enable the diodes specified herein to meet the performance requirements of this specification shall be used. Acceptance or approval of any constituent material shall not guarantee acceptance of the finished product.

#### 4.4.1 Case

The case shall be hermetically sealed and have a ceramic body. The lid shall be welded or preform soldered.

#### 4.4.2 Lead Materials and Finish

- (a) For variants 01, 03 to 06, 08, 10 to 13, 15, 17 to 20, 22, 24 to 27, 29, 31 to 34, 36, 38 to 41, 43 and 45 to 48, the body and lid material shall be Type 'D' with Type '7' finish and the lead material shall be Type 'E' with Type '2' finish in accordance with the requirements of ESCC Basic Specification No 23500.
- (b) For variants 02, 09, 16, 23, 30, 37 and 44, the body and lid material shall be Type 'D' with Type '7' finish in accordance with the requirements of ESCC Basic Specification No 23500.
- (c) For variants 07, 14, 21, 28, 35, 42 and 49, the body material shall be Type 'A' with Type '7' finish and the lid material shall be Type 'D' with Type '7' finish in accordance with the requirements of ESCC Basic Specification No 23500.
- (d) For variants 50 to 56, the lead material shall be Type 'D' with Type '7' finish in accordance with the requirements of ESCC Basic Specification No 23500.

### 4.5 Marking

#### 4.5.1 General

The marking of components delivered to this specification shall be in accordance with the requirements of ESCC Basic Specification No. 21700 and the following paragraphs. When the component is too small to accommodate all of the marking specified, as much as space permits shall be marked and the marking information, in full, shall accompany the component in its primary package.

The information to be marked and the order of precedence, shall be as follows :

- (a) Cathode Identification.
- (b) The ESCC Component Number.
- (c) Traceability Information.

4.5.2 Cathode Identification

Cathode Identification shall be as shown in Figures 2 and 3 of this specification.

4.5.3 The ESCC Component Number

Each component shall bear the ESCC Component Number which shall be constituted and marked as follows:

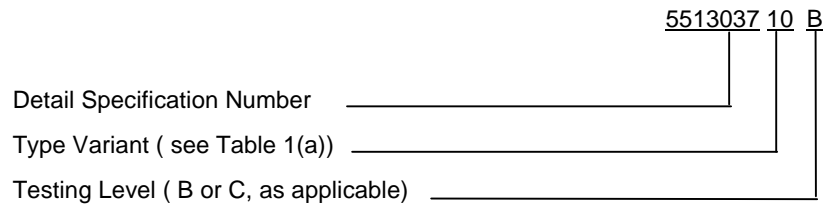

4.5.4 Traceability Information

Each component shall be marked in respect of traceability information as defined in ESCC Basic Specification No. 21700.

4.6 Electrical measurements

4.6.1 Electrical Measurements at Room Temperature

The parameters to be measured at room temperature are scheduled in Table 2. Unless otherwise specified, the measurements shall be performed at  $T_{amb} = + 22 \pm 3^{\circ}C$ .

4.6.2 Electrical Measurements at High and Low Temperatures

The parameters to be measured at high and low temperatures are scheduled in Table 3. Unless otherwise specified, the measurements shall be performed at  $+ 150^{\circ}C (+0-3)^{\circ}C$ .

4.6.3 Circuits for Electrical Measurements

Circuits for use in performed electrical measurements listed in Table 2 of this specification are shown in Figure 4.

4.7 Burn-in tests

Burn-in shall be Category 2 of Chart III (a) of Generic Specification N° 5010.

4.7.1 Parameters Drift Values

The parameter drift values applicable to burn-in are specified in Table 4 of this specification. Unless otherwise stated, the measurements shall be performed at  $T_{amb} = + 22 \pm 3^{\circ}C$ . The parameters drift values ( $\Delta$ ) applicable to the scheduled parameters shall not be exceeded. In addition to these drift value requirements for a given parameter, the appropriate limit value specified in Table 2 shall not be exceeded.

4.7.2 Conditions for High Temperature Reverse Bias Burn-in

The requirements for the High Temperature Reverse Bias Burn-in are specified in Section 7 of ESCC Generic Specification No. 5010. The conditions for High Temperature Reverse Bias Burn-in shall be as specified in Table 5(a) of this specification.

4.7.3 Conditions for Power Burn-in

The requirements of Power Burn-in are specified in Section 7 of ESCC Generic Specification No. 5010. The conditions for Power Burn-in shall be as specified in Table 5(b) of this specification.

4.7.4 Electrical Circuits for High Temperature Reverse Bias and Power Burn-in

Circuits for use in performing the High Temperature Reverse Bias Burn-in test are shown in Figures 5(a) and 5(b) of this specification.

**TABLE 2(a) - ELECTRICAL MEASUREMENTS AT ROOM TEMPERATURE - DC PARAMETERS**

No.	CHARACTERISTICS	SYMBOL	MIL-STD-750 TEST METHOD	TEST CONDITIONS	LIMITS		UNIT
					MIN.	MAX	
1	Reverse Current 1	$I_{R1}$	4016	$V_R = -70V$	-	10	$\mu A$
2	Reverse Current 2	$I_{R2}$	4016	$V_R = -35V$	-	100	nA
3	Forward Voltage	$V_F$	4011	$I_F = 100\text{ mA}$	-	1.1	V
4	Thermal Resistance	$R_{TH(J-C)}$	3101 Variants 01 to 06, 08 to 13, 15 to 20, 22 to 27, 29 to 34, 36 to 41 and 50 to 56.  Variant 07, 14, 21, 28, 35 and 42 to 48.  Variant 49.	Note 1 Power = 0.25 W  Power = 0.50 W  Power = 1.00 W	-	Note 2	$^{\circ}C/W$

**NOTES**

1. Pulsed measurement, pulse width = 10ms.
2. See Item 4 of Table 1(b).

**TABLE 2(b) - ELECTRICAL MEASUREMENTS AT ROOM TEMPERATURE - AC PARAMETERS**

No.	CHARACTERISTICS	SYMBOL	TEST FIG.	MIL-STD-750 TEST METHOD	TEST CONDITIONS	LIMITS		UNIT
						MIN.	MAX	
5	Total Capacitance	$C_T$	-	4001	$V_R = -6V$ $f = 1\text{ MHz}$	-	Note 1	pF
6	Forward Series Resistance	$R_{SF}$	-	4056	$I_F = 10\text{ mA}$ $f_0 = 120\text{ MHz}$	-	Note 2	$\Omega$
7	Minority Carrier Lifetime Note 3	$\tau_L$	4(a)	-	$I_F = 10\text{ mA}$ $I_R = 6\text{ mA}$	-	Note 4	ns

**NOTES**

1. See column 4 of Table 1(a). Junction capacitance = Total capacitance – Case capacitance.  
Typical case capacitance for cases in Figures 2(a) to 2(f) = 0.12 pF.  
Typical case capacitance for cases in Figure 2(g) = 0.18 pF.  
Typical case capacitance for cases in Figure 2(h) = 0.13 pF.
2. See column 5 of Table 1(a).
3. Only during Wafer Screening on a sample of 27 dice per wafer.
4. See Column 6 Table 1(a).

**TABLE 3 - ELECTRICAL MEASUREMENTS AT HIGH AND LOW TEMPERATURES**

No.	CHARACTERISTICS	SYMBOL	MIL-STD-750 TEST METHOD	TEST CONDITIONS	LIMITS		UNIT
					MIN.	MAX	
2	Reverse Current 2	$I_{R2}$	4016	$V_R = -35V$	-	1	$\mu A$

**TABLE 4 - PARAMETER DRIFT VALUES**

No.	CHARACTERISTICS	SYMBOL	SPEC. AND/OR TEST METHOD	TEST CONDITIONS	CHANGE LIMITS ( $\Delta$ )	UNIT
2	Reverse Current 2	$I_{R2}$	As per Table 2	As per Table 2	$\pm 10$ (1) or (2)	nA
					$\pm 100$ (1)	%
3	Forward Voltage	$V_F$			$\pm 5$ (1)	%
5	Total Capacitance	$C_T$			$\pm 5$ (1) (3)	%

**NOTES**

1.  $\Delta 1 = \Delta 2 = \Delta 3$ .
2. Whichever is the greater, referred to the initial measurement.
3. Rounded upwards to the nearest 0.01 pF value. If  $C_T \leq 0,50$  pF then  $\Delta = \pm 10\%$ .

**FIGURE 4 - CIRCUITS FOR ELECTRICAL MEASUREMENTS**

**FIGURE 4(a) - CIRCUIT FOR MESUREMENT OF MINORITY CARRIER LIFETIME**

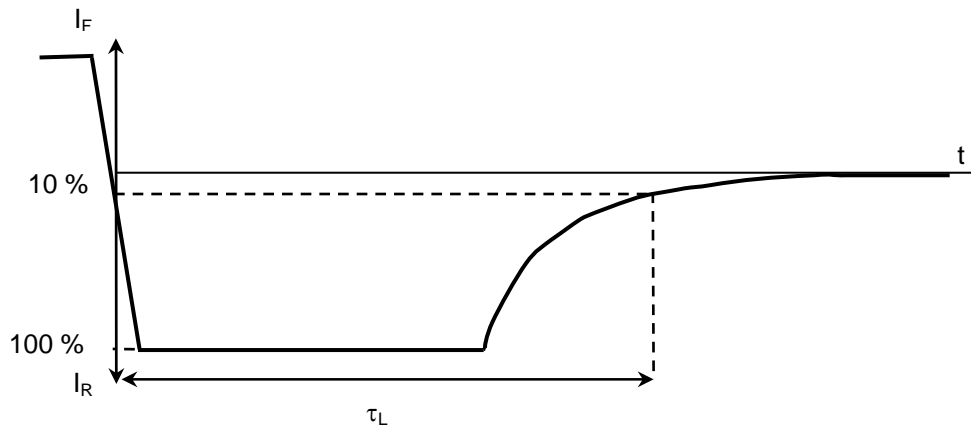
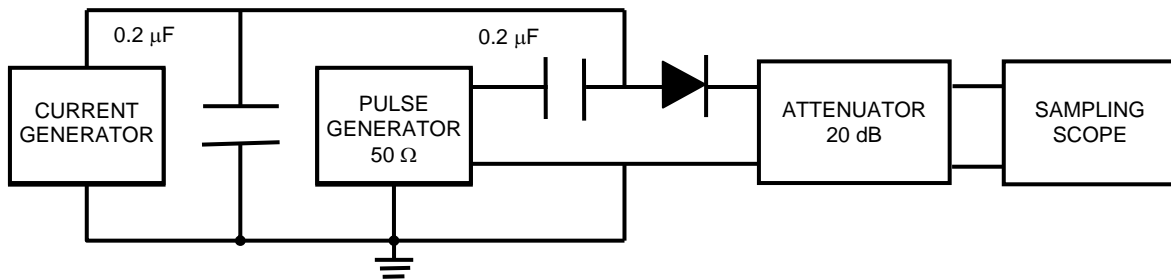

Output waveform

**TABLE 5(a) - CONDITIONS FOR HIGH TEMPERATURE REVERSE BIAS BURN-IN**

No	CHARACTERISTICS	SYMBOL	CONDITIONS	UNIT
1	Ambient Temperature	$T_{amb}$	+ 150 (-0 +3)	°C
2	Reverse Voltage	$V_R$	-52.5	V
3	Duration	t	Note 1	Hours

**NOTES**

1. See ESCC Generic Specification No. 5010.

**TABLE 5(b) - CONDITIONS FOR POWER BURN-IN AND OPERATING LIFE TESTS**

No	CHARACTERISTICS	SYMBOL	CONDITIONS	UNIT
1	Ambient Temperature	$T_{amb}$	+ 125 (-0 +3)	°C
2	Forward Current	$I_F$	Variants 50 to 56 : 30 Variants 01 to 06, 08 to 13 and 15 to 20 : 50 Variants 22 to 27, 29 to 34 and 36 to 41 : 50 Variant 07 and 43 to 48 : 60 Variants 14, 21, 28, 35 and 42 : 80 Variant 49 : 100	mA
3	Duration of Power Burn-In	t	Note 1	Hours
4	Duration of Operating Life Tests	t	Note 1	Hours

**NOTES**

1. See ESCC Generic Specification No. 5010.

**FIGURE 5(a) - ELECTRICAL CIRCUIT FOR HIGH TEMPERATURE REVERSE BIAS BURN-IN**

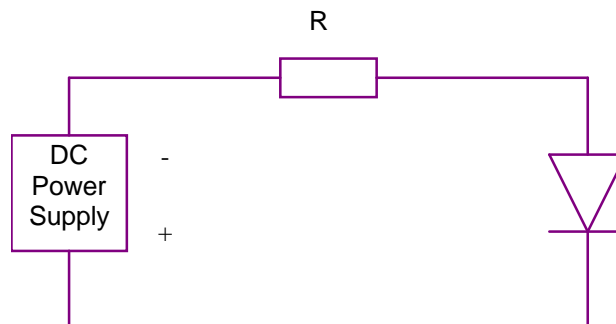

**NOTES**

1 : At the end of the HTRB,  $T_{amb}$  shall be decreased to room temperature and the reverse bias shall remain applied until  $T_{amb} < +35^{\circ}\text{C}$ .

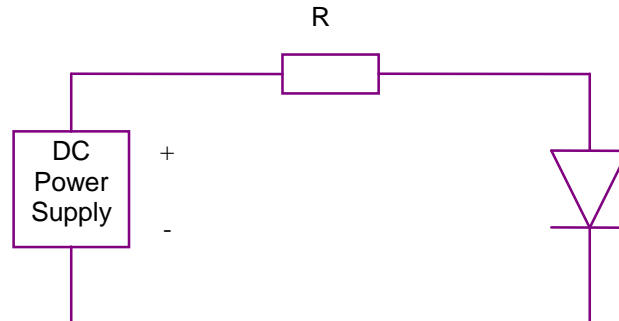
**FIGURE 5(b) - ELECTRICAL CIRCUIT FOR POWER BURN-IN AND OPERATING LIFE TESTS**

#### 4.8 Environmental and endurance tests (Charts IV And V of ESCC Generic Specification No. 5010)

##### 4.8.1 Electrical Measurements on Completion of Environmental Tests

The parameters to be measured on completion of environmental tests are scheduled in Table 2. Unless otherwise stated, the measurements shall be performed at  $T_{amb} = +22 \pm 3^{\circ}\text{C}$ .

##### 4.8.2 Electrical Measurements at Intermediate Points and on Completion of Endurance Tests

The parameters to be measured at intermediate points and on completion of endurance tests are scheduled in Table 6. Unless otherwise stated, the measurements shall be performed at  $T_{amb} = +22 \pm 3^{\circ}\text{C}$ .

##### 4.8.3 Conditions for Operating Life Tests (Part of Endurance Testing)

The requirements for operating life testing are specified in Section 9 of ESCC Generic Specification No. 5010. The conditions for operating life testing are specified in Table 5(b) of this specification.

##### 4.8.4 Electrical Circuits for Operating Life Tests

The circuit to be used for performance of the operating life test shall be the same as shown in Figure 5(b) for Power Burn-in.

#### 4.9 Total Dose Irradiation Testing

Not applicable.

#### 4.10 Special testing

Not applicable.

**TABLE 6 - ELECTRICAL MEASUREMENTS AT INTERMEDIATE POINTS AND ON COMPLETION OF ENDURANCE TESTING**

No.	CHARACTERISTICS	SYMBOL	SPEC. AND/OR TEST METHOD	TEST CONDITIONS	LIMITS		UNIT
					MIN.	MAX.	
1	Reverse Current 1	$I_{R1}$	As per Table 2	As per Table 2	As per Table 2		$\mu$ A
2	Reverse current 2	$I_{R2}$	As per Table 2	As per Table 2	As per Table 2		nA
3	Forward Voltage	$V_F$	As per Table 2	As per Table 2	As per Table 2		V
5	Total Capacitance	$C_T$	As per Table 2	As per Table 2	As per Table 2		pF

**FIGURE 6 – BIAS CONDITIONS FOR IRRADIATION TESTING**

Not applicable

**TABLE 7 – ELECTRICAL MEASUREMENTS DURING AND ON COMPLETION OF IRRADIATION TESTING**

Not applicable

**APPENDIX 'A'****AGREED DEVIATIONS FOR COBHAM MICROWAVE(F)**

ITEMS AFFECTED	DESCRIPTION OF DEVIATIONS
Para. 4.2.2	Para. 9.12, Radiographic Inspection of Chart III(a) : May be performed after Para. 9.7, Particle Impact Noise Detection (PIND) test, in X and Z axes only.
Para. 4.2.3	Para. 9.12, Radiographic Inspection : May be performed after Para. 9.7, PIND test of Chart II(b).