



CONTACTS, ELECTRICAL, TWINAX, CRIMP

FOR 3401/001 CONNECTORS

ESCC Detail Specification No. 3401/069

ISSUE 1

October 2002



	ESCC Detail Specification		PAGE ii ISSUE 1
--	---------------------------	--	--------------------

LEGAL DISCLAIMER AND COPYRIGHT

European Space Agency, Copyright © 2002. All rights reserved.

The European Space Agency disclaims any liability or responsibility, to any person or entity, with respect to any loss or damage caused, or alleged to be caused, directly or indirectly by the use and application of this ESCC publication.

This publication, without the prior permission of the European Space Agency and provided that it is not used for a commercial purpose, may be:

- copied in whole in any medium without alteration or modification.
- copied in part, in any medium, provided that the ESCC document identification, comprising the ESCC symbol, document number and document issue, is removed.



**europaean space agency
agence spatiale européenne**

Pages 1 to 19

CONTACTS, ELECTRICAL, TWINAX, CRIMP

FOR 3401/001 CONNECTORS

ESA/SCC Detail Specification No. 3401/069



**space components
coordination group**

Issue/Rev.	Date	Approved by	
		SCCG Chairman	ESA Director General or his Deputy
Issue 1	April 1999		



ESA/SCC Detail Specification
No. 3401/069

PAGE 2

ISSUE 1

DOCUMENTATION CHANGE NOTICE

Rev. Letter	Rev. Date	Reference	CHANGE Item	Approved DCR No.

**TABLE OF CONTENTS**

	<u>Page</u>
1. <u>GENERAL</u>	5
1.1 Scope	5
1.2 Component Type Variants	5
1.3 Maximum Ratings	5
1.4 Parameter Derating Information	5
1.5 Physical Dimensions	5
2. <u>APPLICABLE DOCUMENTS</u>	5
3. <u>TERMS, DEFINITIONS, ABBREVIATIONS, SYMBOLS AND UNITS</u>	5
4. <u>REQUIREMENTS</u>	12
4.1 General	12
4.2 Deviations from Generic Specification	12
4.2.1 Deviations from Special In-Process Controls	12
4.2.2 Deviations from Final Production Tests	12
4.2.3 Deviations from Burn-in and Electrical Measurements	12
4.2.4 Deviations from Qualification Tests	12
4.2.5 Deviations from Lot Acceptance Tests	12
4.3 Mechanical Requirements	12
4.3.1 Dimension Check	12
4.3.2 Weight	12
4.3.3 Contact Capability	12
4.3.4 Contact Retention	13
4.3.5 Mating and Unmating Forces	13
4.3.6 Insert Retention	13
4.3.7 Jackscrew Retention	13
4.3.8 Contact Insertion and Withdrawal Forces	13
4.3.9 Engagement and Separation Forces	13
4.3.10 Oversize Pin Exclusion	13
4.3.11 Probe Damage Test	14
4.3.12 Solderability	14
4.3.13 Joint Strength	14
4.4 Materials and Finishes	14
4.4.1 Insert	14
4.4.2 Inner and Outer Contacts	14
4.5 Marking	14
4.5.1 General	14
4.5.2 The SCC Component Number	15
4.5.3 Traceability Information	15
4.6 Electrical Measurements	15
4.6.1 Electrical Measurements at Room Temperature	15
4.6.2 Electrical Measurements at High and Low Temperatures	15
4.6.3 Circuits for Electrical Measurements	15
4.7 Screening Tests	15
4.8 Environmental and Endurance Tests	17
4.8.1 Measurements and Inspections on Completion of Environmental Tests	17
4.8.2 Measurements and Inspections at Intermediate Points during Endurance Tests	17
4.8.3 Measurements and Inspections on Completion of Endurance Tests	17
4.8.4 Conditions for Operating Life Tests	17
4.8.5 Electrical Circuit for Operating Life Tests	17
4.8.6 Conditions for High Temperature Storage Test	17

**SCC**ESA/SCC Detail Specification
No. 3401/069

PAGE 4

ISSUE 1

TABLES

	<u>Page</u>
1(a) Type Variants	6
1(b) Maximum Ratings	7
2 Electrical Measurements at Room Temperature	16
3 to 5 Not applicable	N/A
6 Measurements and Inspections on Completion of Environmental and Endurance Testing	18

FIGURES

1 Parameter Derating Information	7
2 Physical Dimensions	8
3 Functional Diagram	N/A
4 Circuits for Electrical Measurements	17

APPENDICES (Applicable to specific Manufacturers only)

None.

**1. GENERAL****1.1 SCOPE**

This specification details the ratings, physical and electrical characteristics, test and inspection data for Contacts, Electrical, Twinax, Crimp, for 3401/001 Connectors.

These contacts shall be procured and packed separately from the connectors.

This specification shall be read in conjunction with:

- ESA/SCC Generic Specification No. 3401, Connectors, Electrical, Non-Filtered, Circular and Rectangular.
- ESA/SCC Detail Specification No. 3401/001, Connectors, Electrical, Rectangular, Non-removable Solder Bucket, PCB and Wire-wrap Contacts and Removable Coaxial and Power Contacts, based on Type D*M.

the requirements of which are supplemented herein.

1.2 COMPONENT TYPE VARIANTS

Variants of the basic type of contacts specified herein, which are also covered by this specification, are scheduled in Table 1(a).

1.3 MAXIMUM RATINGS

The maximum ratings, which shall not be exceeded at any time during use or storage, applicable to the contacts specified herein, are scheduled in Table 1(b).

1.4 PARAMETER DERATING INFORMATION

The applicable derating information for the contacts specified herein is shown in Figure 1.

1.5 PHYSICAL DIMENSIONS

The physical dimensions of the contacts specified herein are shown in Figure 2.

2. APPLICABLE DOCUMENTS

The following documents form part of this specification and shall be read in conjunction with it:-

- (a) ESA/SCC Generic Specification No. 3401, Connectors, Electrical, Non-Filtered, Circular and Rectangular.
- (b) ESA/SCC Detail Specification No. 3401/001, Connectors, Electrical, Rectangular, Non-removable Solder Bucket, PCB and Wire-wrap Contacts and Removable Coaxial and Power Contacts, based on Type D*M.

3. TERMS, DEFINITIONS, ABBREVIATIONS, SYMBOLS AND UNITS

For the purpose of this specification, the terms, definitions, abbreviations, symbols and units specified in ESA/SCC Basic Specification No. 21300 shall apply.



TABLE 1(b) - MAXIMUM RATINGS

No.	CHARACTERISTICS	SYMBOL	MAXIMUM RATINGS	UNIT	REMARKS
1	Working Voltage Sea Level Variants 01, 02, 05, 06 Variants 03, 04, 07, 08	U_R	1 000 500	Vrms	Note 1
2	Rated Current (Centre Contact)	I_{cr}	5.0	A	
3	Frequency Range	f	0 to 10	MHz	Note 2
4	Transfer Impedance	ZT	0.01	Ω	$f \leq 100\text{MHz}$
5	Operating Temperature Range	T_{op}	- 55 to + 125	$^{\circ}\text{C}$	
6	Storage Temperature Range	T_{stg}	- 55 to + 125	$^{\circ}\text{C}$	

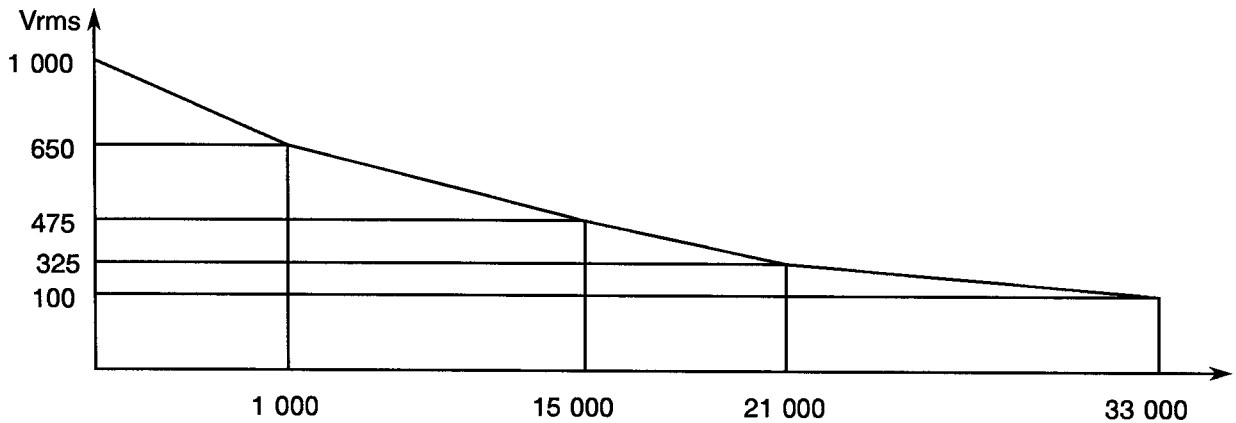
NOTES

1. Between contacts.
2. Compatible with 1553 Bus Line.

FIGURE 1 - PARAMETER DERATING INFORMATION

VOLTAGE PROOF VERSUS ALTITUDE

Straight and 90° Rear-end Contacts - (Inner/Inner)



Straight and 90° Rear-end Contacts - (Inner/Outer)

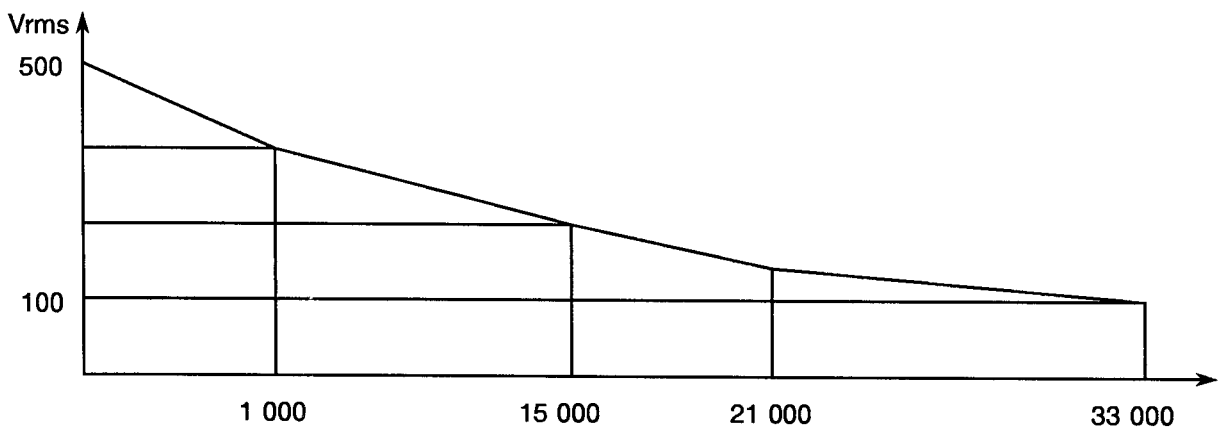
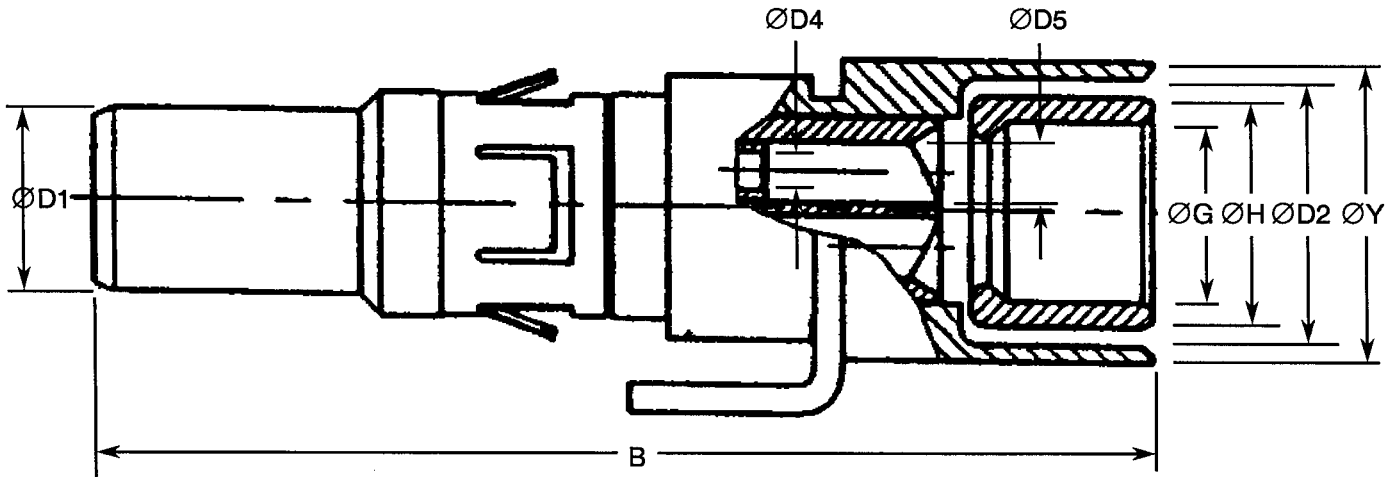


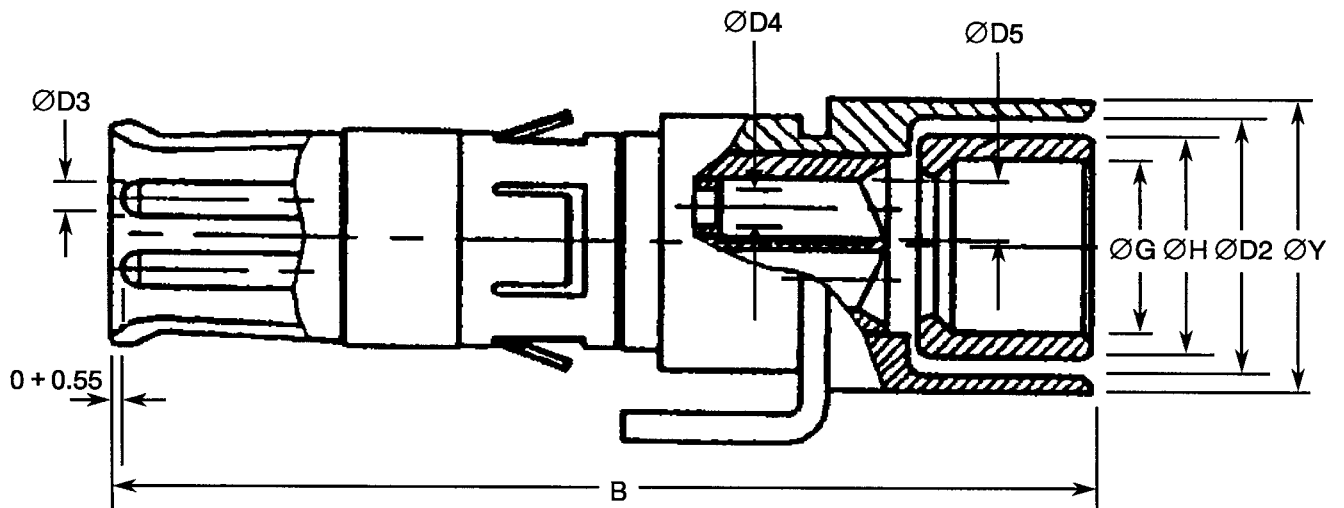


FIGURE 2 - PHYSICAL DIMENSIONS

VARIANTS 01 AND 05, MALE CONTACT



VARIANTS 02 AND 06, FEMALE CONTACT

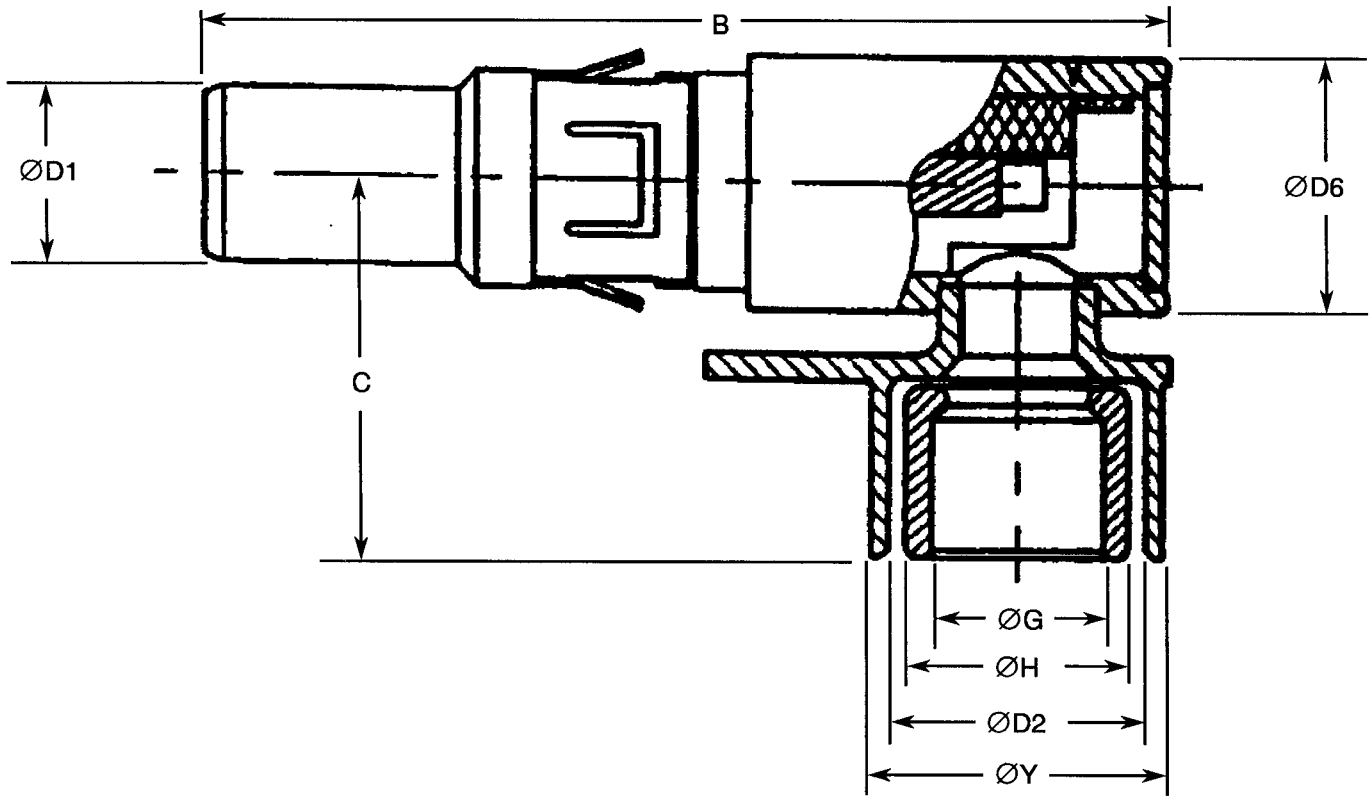


NOTES: See Page 11.

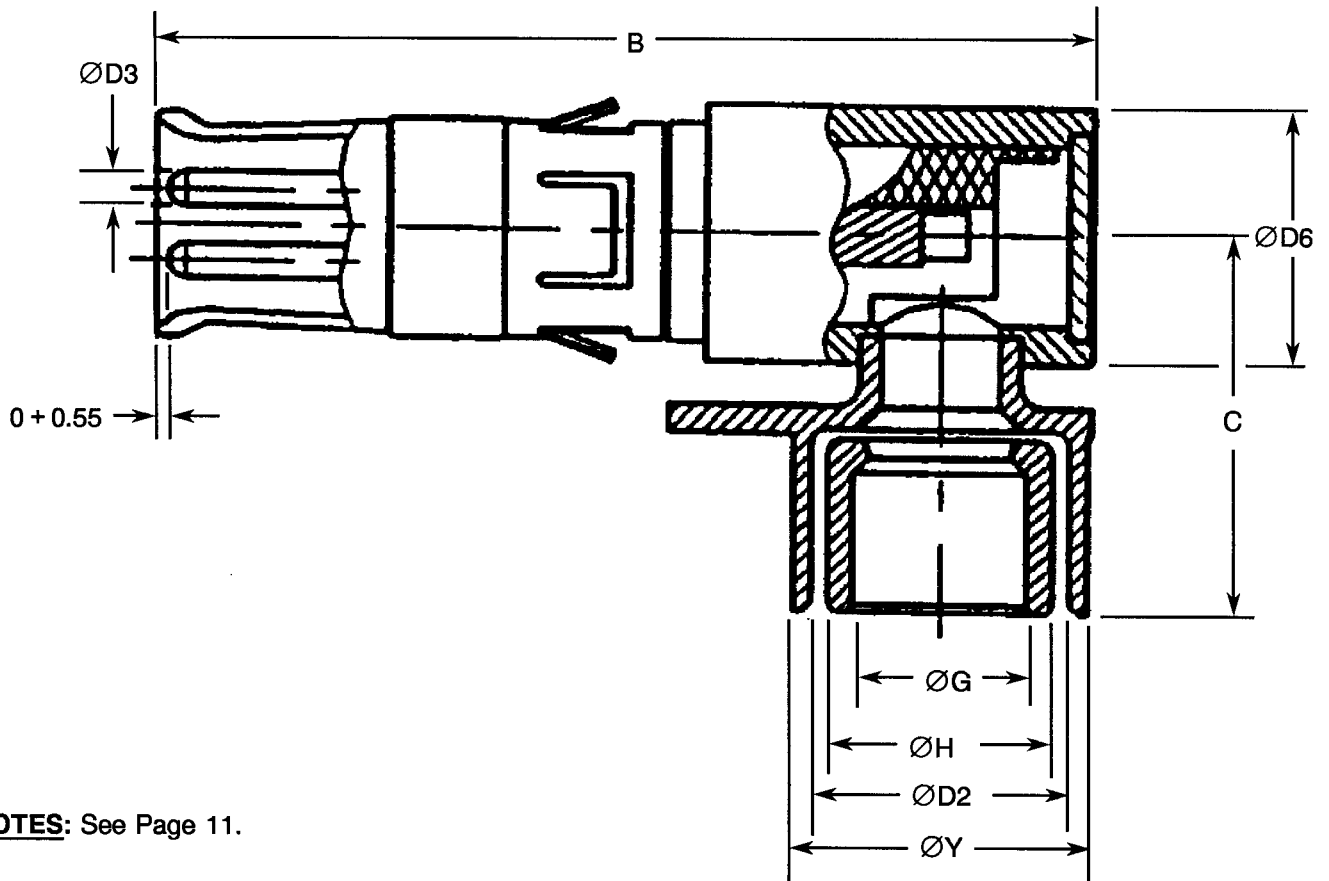


FIGURE 2 - PHYSICAL DIMENSIONS (CONTINUED)

VARIANT 03 AND 07, MALE CONTACT



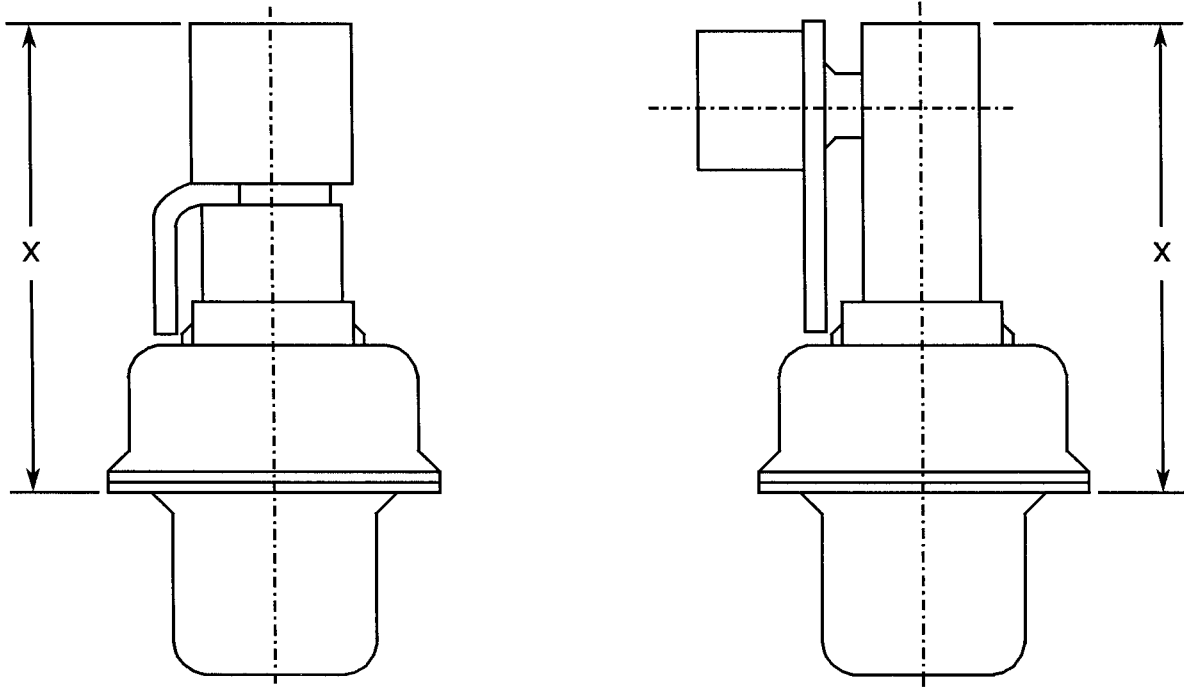
VARIANTS 04 AND 08, FEMALE CONTACT



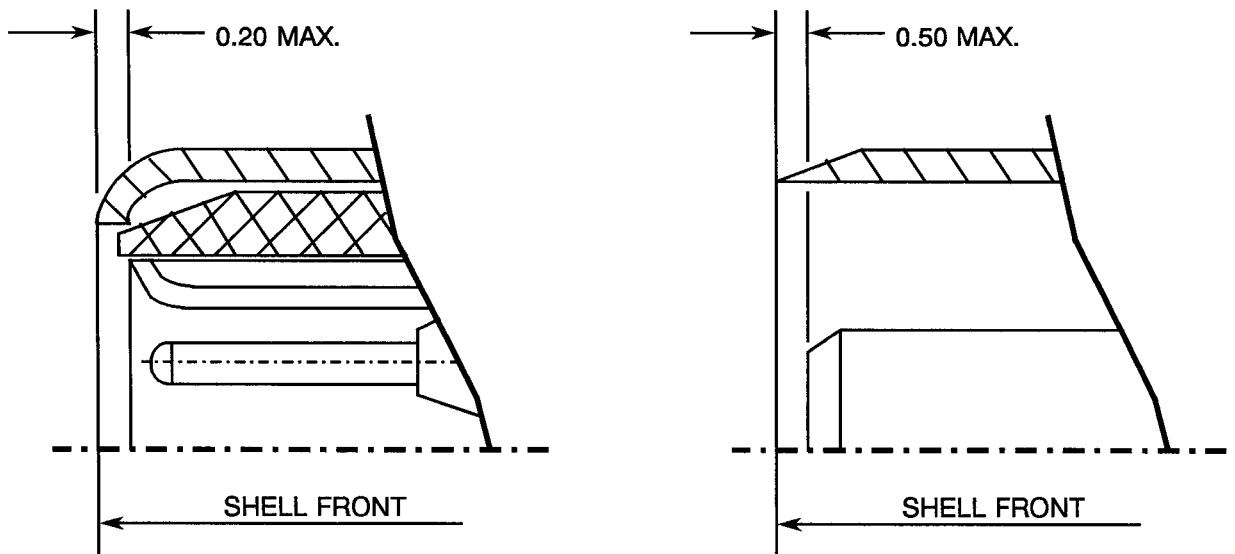
NOTES: See Page 11.



FIGURE 2 - PHYSICAL DIMENSIONS (CONTINUED)



Maximum protrusion of contacts relative to rear of shell flange



Maximum recess of contacts relative to front of shell

NOTES: See Page 11.

FIGURE 2 - PHYSICAL DIMENSIONS (CONTINUED)

	ØD1	ØD2	ØD3	ØD4	ØD5	ØD6
MIN.	3.86	5.65	0.76	0.75	1.28	5.5
MAX.	3.90	5.70	0.78	0.79	1.33	5.7

Variant	B (Max)	C (Max)	ØG (Min)	ØH (Min)	X (Max)		ØY (Max)
					(2) (3)	(4)	
01	22.26	-	3.79	4.86	17	17.20	6.36
02	21.57	-	3.79	4.86	16.40	-	6.36
03	21.16	8.45	3.79	4.86	15.90	16.10	6.44
04	20.57	8.45	3.79	4.86	15.40	-	6.44
05	22.26	-	3.49	5.06	17	17.20	6.36
06	21.57	-	3.49	5.06	16.40	-	6.36
07	21.16	8.45	3.49	5.06	15.90	16.10	6.44
08	20.57	8.45	3.49	5.06	15.40	-	6.44

NOTES

1. All dimensions are in millimetres.
2. Connectors equipped with male contacts, Shell Sizes E and A.
3. Connectors equipped with female contacts, all sizes.
4. Connectors equipped with male contacts, Shell Sizes B, C and D.



4. REQUIREMENTS

4.1 GENERAL

The complete requirements for procurement of the contacts specified herein shall be as stated in this specification and ESA/SCC Generic Specification No. 3401. Deviations from the Generic Specification, applicable to this specification only, are listed in Para. 4.2.

Deviations from the applicable Generic Specification and this Detail Specification, formally agreed with specific Manufacturers on the basis that the alternative requirements are equivalent to the ESA/SCC requirements and do not affect the components' reliability, are listed in the appendices attached to this specification.

4.2 DEVIATIONS FROM GENERIC SPECIFICATION

4.2.1 Deviations from Special In-process Controls

None.

4.2.2 Deviations from Final Production Tests

None.

4.2.3 Deviations from Burn-in and Electrical Measurements (Chart III)

Not applicable.

4.2.4 Deviations from Qualification Tests (Chart IV)

- (a) Para. 9.15, Joint Strength: Shall be performed as specified in Para. 4.3.13 of this specification.
- (b) Para. 9.26, Overload Test: Not applicable.
- (c) Para. 9.31, Solderability: Not applicable.

4.2.5 Deviations from Lot Acceptance Tests (Chart V)

- (a) Para. 9.15, Joint Strength: Shall be performed as specified in Para. 4.3.13 of this specification.
- (b) Para. 9.31, Solderability: Not applicable.

4.3 MECHANICAL REQUIREMENTS

4.3.1 Dimension Check

The dimensions of the contacts specified herein shall be verified in accordance with the requirements set out in Para. 9.6 of ESA/SCC Generic Specification No. 3401 and shall conform to those shown in Figure 2 of this specification

4.3.2 Weight

The maximum weight of the contacts specified herein shall be as given in Table 1(a).

4.3.3 Contact Capability

For the purpose of this test, the pick-up and drop weights shall be as follows.

4.3.3.1 Inner Contact (Variants 01, 03, 05 and 07)

	PICK-UP WEIGHT	DROP WEIGHT	UNITS
WEIGHT	19.84	226.80	g
PIN DIAMETER	0.749 to 0.751	0.773 to 0.775	mm
INSERTION DEPTH	3.0	3.0	mm

4.3.3.2 Outer Contact (Variants 02, 04, 06 and 08)

	PICK-UP WEIGHT	DROP WEIGHT	UNITS
WEIGHT	85	700	g
PIN DIAMETER	3.857 to 3.862	3.857 to 3.862	mm
INSERTION DEPTH	4.0	4.0	mm

4.3.4 Contact Retention (In Insert)

The contact retention within the insert shall be as specified in Table 1(a). There shall be no displacement of the contact in excess of 0.3mm.

4.3.5 Mating and Unmating Forces

As specified in ESA/SCC Detail Specification No. 3401/001.

4.3.6 Insert Retention (In Shell)

As specified in ESA/SCC Detail Specification No. 3401/001.

4.3.7 Jackscrew Retention

As specified in ESA/SCC Detail Specification No. 3401/001.

4.3.8 Contact Insertion and Withdrawal Forces

Insertion and withdrawal forces of the contacts shall be as specified in Table 1(a).

4.3.9 Engagement and Separation Forces

4.3.9.1 Inner Contacts (Variants 01, 03, 05 and 07)

The contact engagement and separation forces shall be as follows.

TEST PIN DIAMETER (mm)	ENGAGEMENT MAXIMUM (N)	SEPARATION (N)	
		MIN.	MAX.
0.749 to 0.751	-	0.20	-
0.773 to 0.775	330	-	0.22

4.3.9.2 Outer Contact (Variants 02, 04, 06 and 08)

The contact engagement forces shall be as follows.

TEST PIN DIAMETER (mm)	ENGAGEMENT MINIMUM (N)	ENGAGEMENT MAXIMUM (N)
3.857 to 3.862	0.85	7.0

4.3.10 Oversize Pin Exclusion

Not applicable.

**4.3.11 Probe Damage Test**

Not applicable.

4.3.12 Solderability

Not applicable.

4.3.13 Joint Strength

- (a) The contact shall be assembled to its test cable as specified in Table 1(a). It shall be firmly fixed and a movable sleeve or equivalent attached to the cable. The sleeve shall then be moved away from the fixed contact longitudinally and gradually, and in such a manner that the cable remains unbent and untwisted. A scale for measuring the retention force shall be attached to the sleeve. The force shall be maintained for 30 seconds minimum.
- (b) The assembly, still under tension, shall be tested for contact resistance (inner and outer contacts) and shall then be examined for mechanical failure, loosening or rupture.
- (c) With the contact still in the fixed position, the cable shall be held at a point 50 times the diameter of the cable from the contact and a torque shall be applied in both directions up to an angle of 90°.
- (d) The cable shall then be bent at a radius of 10 times the diameter of the cable, starting at the contact, at an angle of $90^\circ \pm 5^\circ$ from the axis of the contact, then reversed $180^\circ \pm 10^\circ$.
- (e) On completion of the testing, Low Level Contact Resistance shall be measured and shall not exceed the value specified in Table 6 of this specification.

4.4 MATERIALS AND FINISHES

The materials and finishes shall be as specified herein. Where a definite material is not specified, a material which will enable the contacts specified herein to meet the performance requirements of this specification shall be used. Acceptance or approval of any constituent material does not guarantee acceptance of the finished product.

4.4.1 Insert

Epoxy 3505 or equivalent.

4.4.2 Inner and Outer Contacts

The contacts shall be made of copper base alloy selected from raw materials with a minimum of impurities. The contacts shall be plated as follows:

- 1.27µm minimum gold plate over 3.0µm minimum of copper.

4.5 MARKING**4.5.1 General**

The marking of all components delivered to this specification shall be in accordance with with the requirements of ESA/SCC Basic Specification No. 21700 and the following paragraphs. These components being too small to accommodate the marking, the marking requirements, in full, shall accompany each lot of components in its primary package.

Such marking shall comprise:-

- (a) The SCC Component Number.
- (b) Traceability Information.
- (c) Quantity of Components.

**4.5.2 The SCC Component Number**

The SCC Component Number shall be constituted and marked as follows:

Detail Specification Number _____ **340106901B**
Type Variant (see Table 1(a)) _____
Testing Level _____

4.5.3 Traceability Information

Traceability information shall be marked in accordance with the requirements of ESA/SCC Basic Specification No. 21700.

4.6 ELECTRICAL MEASUREMENTS**4.6.1 Electrical Measurements at Room Temperature**

The parameters to be measured in respect of electrical characteristics are listed in Table 2. Unless otherwise specified, the measurements shall be performed at $T_{amb} = +22 \pm 3$ °C.

Contact resistance shall be measured on both the engaged outer and inner conductor contacts.

4.6.2 Electrical Measurements at High and Low Temperatures (Table 3)

Not applicable.

4.6.3 Circuits for Electrical Measurements

A circuit for measuring Contact Resistance is shown in Figure 4 of this specification.

4.7 SCREENING TESTS (TABLES 4 AND 5)

Not applicable.

**TABLE 2 - ELECTRICAL MEASUREMENTS AT ROOM TEMPERATURE**

No.	CHARACTERISTICS	SYMBOL	ESA/SCC 3401 TEST METHOD	TEST CONDITIONS	LIMITS		UNIT
					MIN.	MAX.	
1	Insulation Resistance (Centre to Centre Contact)	R _i	Para. 9.1.1.1	Para. 9.1.1.1	5 000	-	MΩ
2	Voltage Proof Leakage Current 1 (Centre to Outer Contact) (Straight Rear End)	I _{L1}	Para. 9.1.1.2	Para. 9.1.1.2 VP = 500Vrms	-	2.0	mA
3	Voltage Proof Leakage Current 2 (Centre to Outer Contact) (90° Rear End)	I _{L2}	Para. 9.1.1.2	Para. 9.1.1.2 VP = 500Vrms	-	2.0	mA
4	Voltage Proof Leakage Current 3 (Centre to Centre Contact) (Straight Rear End)	I _{L3}	Para. 9.1.1.2	Para. 9.1.1.2 VP = 1 000Vrms	-	2.0	mA
5	Voltage Proof Leakage Current 4 (Centre to Centre Contact) (90° Rear End)	I _{L4}	Para. 9.1.1.2	Para. 9.1.1.2 VP = 1 000Vrms	-	2.0	mA
6	Contact Resistance (Low Level Current) (Centre and Outer Contacts)	R _{cl}	Para. 9.1.1.3	Para. 9.1.1.3 and Figure 4	-	8.5	mΩ
7	Contact Resistance (Rated Current) (Centre Contact)	R _{cr}	Para. 9.1.1.3	Para. 9.1.1.3 and Figure 4 5.0A	-	8.5	mΩ

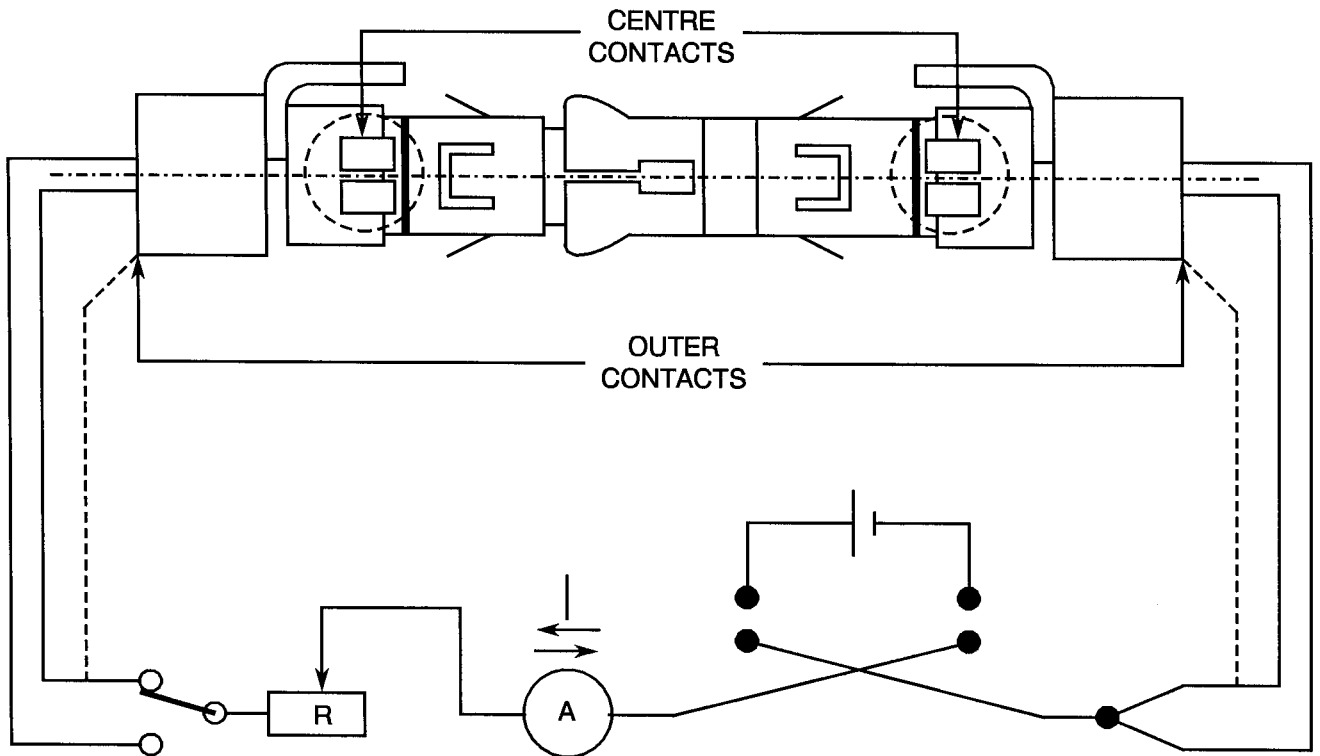
TABLES 3, 4 AND 5

Not applicable.



FIGURE 4 - CIRCUITS FOR ELECTRICAL MEASUREMENTS

CONTACT RESISTANCE



4.8 ENVIRONMENTAL AND ENDURANCE TESTS (CHARTS IV AND V OF ESA/SCC GENERIC SPECIFICATION No. 3401)

4.8.1 Measurements and Inspections on Completion of Environmental Tests

The parameters to be measured and inspections to be performed on completion of environmental testing are scheduled in Table 6. Unless otherwise specified, the measurements shall be performed at $T_{amb} = +22 \pm 3$ °C.

4.8.2 Measurements and Inspections at Intermediate Points during Endurance Tests

Not applicable.

4.8.3 Measurements and Inspections on Completion of Endurance Tests

The parameters to be measured and inspections to be performed on completion of endurance tests shall be those specified in Table 6. Unless otherwise specified, the measurements shall be performed at $T_{amb} = +22 \pm 3$ °C.

4.8.4 Conditions for Operating Life Tests (Part of Endurance Testing)

Not applicable.

4.8.5 Electrical Circuit for Operating Life Tests

Not applicable.

4.8.6 Conditions for High Temperature Storage Test (Part of Endurance Testing)

Not applicable.



TABLE 6 - MEASUREMENTS AND INSPECTIONS ON COMPLETION OF ENVIRONMENTAL AND ENDURANCE TESTING

NO.	ESA/SCC GENERIC NO. 3401		MEASUREMENTS AND INSPECTIONS		SYMBOL	LIMITS		UNIT
	ENVIRONMENTAL AND ENDURANCE TESTS (1)	TEST METHOD AND CONDITIONS	IDENTIFICATION	CONDITIONS		MIN	MAX	
01	Seal Test	Para. 9.9	Not applicable					
02	Wiring	Para. 9.10 and Table 1(a) of this spec.	Visual Examination Low Level Contact Resistance	Table 2 Item 6	Rcl	Table 2 Item 6		
03	Vibration	Para. 9.11	ESA/SCC 3401/001					
04	Shock or Bump	Para. 9.12	ESA/SCC 3401/001					
05	Climatic Sequence	Para. 9.13	ESA/SCC 3401/001					
06	Plating Thickness	Para. 9.14	Thickness	-	-	Para. 4.4.2 of this spec		
07	Joint Strength	Para. 9.15 and Paras. 4.2.4 and 4.2.5 of this spec.	Para. 4.3.13 of this spec. Final Measurements Low level Contact Resistance	Force = 68.1N (Min.) Table 2 Item 6	Rcl	Table 2 Item 6		
08	Rapid Change of Temperature	Para. 9.16	ESA/SCC 3401/001					
09	Contact Retention (In Insert)	Para. 9.17 & Para. 4.3.4 of this spec	Contact Displacement		-	ESA/SCC 3401 Para. 9.17		
10	Endurance	Para. 9.18	Initial Measurements Low Level Contact Resistance Final Measurements Insulation Resistance Voltage Proof Leak Current Voltage Proof Leak Current Voltage Proof Leak Current Voltage Proof Leak Current Low Level Contact Resistance Drift	Table 2 Item 6 Table 2 Item 1 Table 2 Item 2 Table 2 Item 3 Table 2 Item 4 Table 2 Item 5 Table 2 Item 6	Rcl Ri I _{L1} I _{L2} I _{L3} I _{L4} ΔRcl	Record Values Table 2 Item 1 - 2.0 - 2.0 - 2.0 - 2.0 - 2.0	mA mA mA mA mΩ	
11	Permanence of Marking	Para. 9.19	Not applicable					
12	Mating/Unmating Forces	Para. 9.20	ESA/SCC 3401/001					

NOTES

1. The tests in this table refer to either Chart IV or V and shall be used as applicable.



SCC

ESA/SCC Detail Specification
No. 3401/069

PAGE 19

ISSUE 1

TABLE 6 - MEASUREMENTS AND INSPECTIONS ON COMPLETION OF ENVIRONMENTAL AND ENDURANCE TESTING (CONT'D)

NO.	ESA/SCC GENERIC NO. 3401		MEASUREMENTS AND INSPECTIONS		SYMBOL	LIMITS		UNIT
	ENVIRONMENTAL AND ENDURANCE TESTS (1)	TEST METHOD AND CONDITIONS	IDENTIFICATION	CONDITIONS		MIN	MAX	
13	High Temperature Storage	Para. 9.21	Initial Measurements Low Level Contact Resist Final Measurements Insulation Resistance Voltage Proof Leak Current Voltage Proof Leak Current Voltage Proof Leak Current Voltage Proof Leak Current Low Level Contact Resistance Drift Rated Current Contact Resistance Contact Retention (In Insert)	Table 2 Item 6 Table 2 Item 1 Table 2 Item 2 Table 2 Item 3 Table 2 Item 4 Table 2 Item 5 Table 2 Item 6 Table 2 Item 7 Para. 4.3.4 of this spec.	Rcl Ri I _{L1} I _{L2} I _{L3} I _{L4} ΔRcl Rcr -	Record Values Table 2 Item 1 - 2.0 - 2.0 - 2.0 - 2.0 - 2.0 - 2.0 Table 2 Item 7 ESA/SCC 3401 Para. 9.17	mA mA mA mA mΩ	
14	Corrosion	Para. 9.22	Visual Examination	-	-	-	-	
15	Insert Retention (In Shell)	Para. 9.23 & Para. 4.3.6 of this spec	ESA/SCC 3401/001					
16	Jackscrew Retention	Para. 9.24 & Para. 4.3.7 of this spec	ESA/SCC 3401/001					
17	High Temperature Measurements	Para. 9.25	ESA/SCC 3401/001					
18	Overload Test	Para. 9.26 and Para. 4.2.4 of this spec.	Not applicable					
19	Maintenance Aging	Para. 9.27	Visual Examination Contact Retention (In Insert) Contact Insertion & Withdrawal Forces	- Para. 4.3.4 of this spec. Para. 4.3.8 of this spec.	- - -	- - -	- - -	- - -
20	Engage/Separation Forces	Para. 9.28 & Para. 4.3.9 of this spec	Force		F		Para. 4.3.9	
21	Oversize Pin Exclusion	Para. 9.29 & Para. 4.3.10 of this spec	Not applicable					
22	Probe Damage	Para. 9.30 & Para. 4.3.11 of this spec	Not applicable					
23	Solderability	Para. 9.31 & Para. 4.3.12 of this spec	Not applicable					

NOTES: See Page 18.