



Pages 1 to 23

**LIGHTWEIGHT ACCESSORIES FOR RECTANGULAR
CONNECTORS, 3401/001 AND 3401/002**

ESCC Detail Specification No. 3401/072

Issue 5	October 2010
---------	--------------



Document Custodian: European Space Agency - see <https://escies.org>

LEGAL DISCLAIMER AND COPYRIGHT

European Space Agency, Copyright © 2010. All rights reserved.

The European Space Agency disclaims any liability or responsibility, to any person or entity, with respect to any loss or damage caused, or alleged to be caused, directly or indirectly by the use and application of this ESCC publication.

This publication, without the prior permission of the European Space Agency and provided that it is not used for a commercial purpose, may be:

- copied in whole, in any medium, without alteration or modification.
- copied in part, in any medium, provided that the ESCC document identification, comprising the ESCC symbol, document number and document issue, is removed.

DOCUMENTATION CHANGE NOTICE

(Refer to <https://escies.org> for ESCC DCR content)

DCR No.	CHANGE DESCRIPTION
618	Specification upissued to include editorial and technical changes per DCR.

TABLE OF CONTENTS

1.	<u>GENERAL</u>	5
1.1	Scope	5
1.2	Component Type Variants	5
1.3	Maximum Ratings	5
1.4	Parameter Derating Information	5
1.5	Physical Dimensions	5
2.	<u>APPLICABLE DOCUMENTS</u>	5
3.	<u>TERMS, DEFINITIONS, ABBREVIATIONS, SYMBOLS AND UNITS</u>	5
4.	<u>REQUIREMENTS</u>	20
4.1	General	20
4.2	Deviations from Generic Specification	20
4.2.1	Deviations from Special In-Process Controls	20
4.2.2	Deviations from Final Production Tests (Chart II)	21
4.2.3	Deviations from Burn-in and Electrical Measurements (Chart III)	21
4.2.4	Deviations from Qualification Tests (Chart IV)	21
4.2.5	Deviations from Lot Acceptance Tests (Chart V)	21
4.3	Mechanical Requirements	21
4.3.1	Dimension Check	21
4.3.2	Weight	21
4.3.3	Torque Value	21
4.4	Materials and Finishes	21
4.4.1	Screw Lock Assemblies (Male and Female)	21
4.4.2	Lightweight Backshell	21
4.4.3	Castellated Backshell	22
4.4.4	EMI Gasket	22
4.4.5	Magnetism Level	22
4.5	Marking	22
4.5.1	General	22
4.5.2	The ESCC Component Number	22
4.5.3	Characteristics	22
4.5.3.1	Magnetism Level (For all Variants, except Variants 03, 04, 68 to 71)	22
4.5.4	Traceability Information	23
4.6	Electrical Measurements (Tables 2 and 3)	23
4.7	Burn-in and Electrical Measurements (Tables 4 and 5)	23
4.8	Environmental and Endurance Tests (Table 6)	23

1. GENERAL

1.1 SCOPE

This specification details the ratings, physical and electrical characteristics, test and inspection data for Lightweight Accessories for Rectangular Connectors (D*M and D*MA). It shall be read in conjunction with ESCC Generic Specification No. 3401, the requirements of which are supplemented herein and ESCC Detail Specifications Nos. 3401/001 and 3401/002.

1.2 COMPONENT TYPE VARIANTS

The type variants of accessories covered by this specification are given in Table 1(a).

1.3 MAXIMUM RATINGS

The maximum ratings, which shall not be exceeded at any time during use or storage, applicable to the accessories specified herein, are given in Table 1(b).

1.4 PARAMETER DERATING INFORMATION

Not applicable.

1.5 PHYSICAL DIMENSIONS

The physical dimensions of the accessories specified herein are shown in Figure 2.

2. APPLICABLE DOCUMENTS

The following documents form part of this specification and shall be read in conjunction with it:

- (a) ESCC Generic Specification No. 3401, Connectors, Electrical, Circular and Rectangular.
- (b) ESCC Detail Specification No. 3401/001, Connectors, Electrical, Rectangular, Miniature, Non-removable Solder and Wire-Wrap-Type Contacts and, Removable Coaxial and Power, Crimp-Type and Solder-Type Contacts, based on Type D*M.
- (c) ESCC Detail Specification No. 3401/002, Connectors, Electrical, Rectangular, Miniature, Removable Crimp Type Contacts and, Removable Coaxial and Power Crimp-Type and Solder-Type Contacts, based on type D*MA.

3. TERMS, DEFINITIONS, ABBREVIATIONS, SYMBOLS AND UNITS

For the purpose of this specification, the terms, definitions, abbreviations, symbols and units specified in ESCC Basic Specification No. 21300 shall apply.

TABLE 1(a) - TYPE VARIANTS

VARIANT	DESCRIPTION		WEIGHT (g)
01	Screw Lock Assembly Brass (Male/hex. hole 2.38 head screw)	With Back Shell	1.5
02	Screw Lock Assembly Brass (Male/hex. hole 2.38 head screw)	With Back Shell	1.5
03	Screw Lock Assembly Stainless Steel (Male/hex. hole 2.38 head screw)	With Back Shell	1.5

VARIANT	DESCRIPTION		WEIGHT (g)
04	Screw Lock Assembly Stainless Steel (Male/hex. hole 2.38 head screw)	With Back Shell	1.5
05	Backshell: Lightweight Design with Saddle Clamps for Strain Relief	Size E	15.5
06	Backshell: Lightweight Design with Saddle Clamps for Strain Relief	Size A	19
07	Backshell: Lightweight Design with Saddle Clamps for Strain Relief	Size B	23
08	Backshell: Lightweight Design with Saddle Clamps for Strain Relief	Size C	29
09	Backshell: Lightweight Design with Saddle Clamps for Strain Relief	Size D	33
10	Backshell: Lightweight D-SUB Shorting Can	Size E	8
11	Backshell: Lightweight D-SUB Shorting Can	Size A	10
12	Backshell: Lightweight D-SUB Shorting Can	Size B	14
13	Backshell: Lightweight D-SUB Shorting Can	Size C	20
14	Backshell: Lightweight D-SUB Shorting Can	Size D	26
15	Backshell: EMI Shielded Straight Cable Outlet - Front Mount	Size E	21
16	Backshell: EMI Shielded Straight Cable Outlet - Front Mount	Size A	26
17	Backshell: EMI Shielded Straight Cable Outlet - Front Mount	Size B	30
18	Backshell: EMI Shielded Straight Cable Outlet - Front Mount	Size C	35
19	Backshell: EMI Shielded Straight Cable Outlet - Front Mount	Size D	40
20	Backshell: EMI Shielded Straight Cable Outlet - Rear Mount	Size E	21
21	Backshell: EMI Shielded Straight Cable Outlet - Rear Mount	Size A	26
22	Backshell: EMI Shielded Straight Cable Outlet - Rear Mount	Size B	30
23	Backshell: EMI Shielded Straight Cable Outlet - Rear Mount	Size C	35
24	Backshell: EMI Shielded Straight Cable Outlet - Rear Mount	Size D	40
25	Backshell: Lightweight Shielded Backshell - 90° Longitudinal Right Cable Outlet	Size E	7
26	Backshell: Lightweight Shielded Backshell - 90° Longitudinal Right Cable Outlet	Size A	10
27	Backshell: Lightweight Shielded Backshell - 90° Longitudinal Right Cable Outlet	Size B	13.5
28	Backshell: Lightweight Shielded Backshell - 90° Longitudinal Right Cable Outlet	Size C	18
29	Backshell: Lightweight Shielded Backshell - 90° Longitudinal Right Cable Outlet	Size D	23
30	Backshell: Lightweight Shielded Backshell - 90° Longitudinal Left Cable Outlet	Size E	7
31	Backshell: Lightweight Shielded Backshell - 90° Longitudinal Left Cable Outlet	Size A	10
32	Backshell: Lightweight Shielded Backshell - 90° Longitudinal Left Cable Outlet	Size B	13.5
33	Backshell: Lightweight Shielded Backshell - 90° Longitudinal Left Cable Outlet	Size C	18

VARIANT	DESCRIPTION	WEIGHT (g)
34	Backshell: Lightweight Shielded Backshell - 90° Longitudinal Left Cable Outlet	Size D 23
35	Backshell: Lightweight Shielded Backshell Straight Cable Outlet	Size E 6.5
36	Backshell: Lightweight Shielded Backshell Straight Cable Outlet	Size A 8.5
37	Backshell: Lightweight Shielded Backshell Straight Cable Outlet	Size B 11.5
38	Backshell: Lightweight Shielded Backshell Straight Cable Outlet	Size C 13.5
39	Backshell: Lightweight Shielded Backshell Straight Cable Outlet	Size D 14.5
40	Backshell: Lightweight Dual Entry Bend Termination, 15 Pin	Size A 23
41	Castellated Backshell	Size E 2
42	Castellated Backshell	Size A 2.5
43	Castellated Backshell	Size B 3
44	Castellated Backshell	Size C 3.9
45	Castellated Backshell	Size D 4
46	Backshell: Straight Lightweight Backshell Ultra Elliptical Band Termination	Size E 8
47	Backshell: Straight Lightweight Backshell Ultra Elliptical Band Termination	Size A 13
48	Backshell: Straight Lightweight Backshell Ultra Elliptical Band Termination	Size B 18
49	Backshell: Straight Lightweight Backshell Ultra Elliptical Band Termination	Size C 23
50	Backshell: Straight Lightweight Backshell Ultra Elliptical Band Termination	Size D 28
51	Backshell: 45° Lightweight Backshell Ultra Elliptical Band Termination, Right	Size E 10
52	Backshell: 45° Lightweight Backshell Ultra Elliptical Band Termination, Right	Size A 14
53	Backshell: 45° Lightweight Backshell Ultra Elliptical Band Termination, Right	Size B 20
54	Backshell: 45° Lightweight Backshell Ultra Elliptical Band Termination, Right	Size C 26
55	Backshell: 45° Lightweight Backshell Ultra Elliptical Band Termination, Right	Size D 33
56	Backshell: 45° Lightweight Backshell Ultra Elliptical Band Termination, Left	Size E 10
57	Backshell: 45° Lightweight Backshell Ultra Elliptical Band Termination, Left	Size A 14
58	Backshell: 45° Lightweight Backshell Ultra Elliptical Band Termination, Left	Size B 20
59	Backshell: 45° Lightweight Backshell Ultra Elliptical Band Termination, Left	Size C 26
60	Backshell: 45° Lightweight Backshell Ultra Elliptical Band Termination, Left	Size D 33

VARIANT	DESCRIPTION		WEIGHT (g)
61	Backshell: Lightweight D-SUB Extra-Shorting Can	Size E	8
62	Backshell: Lightweight D-SUB Extra-Shorting Can	Size A	10
63	Backshell: Lightweight D-SUB Extra-Shorting Can	Size B	14
64	Backshell: Lightweight D-SUB Extra-Shorting Can	Size C	20
65	Backshell: Lightweight D-SUB Extra-Shorting Can	Size D	26
66	Screw Lock Assembly Brass (Male/hex. hole 2.0 head screw)	With Back Shell	1.5
67	Screw Lock Assembly Brass (Male/hex. hole 2.0 head screw)	With Back Shell	1.5
68	Screw Lock Assembly Stainless Steel (Male/hex. hole 2.0 head screw)	With Back Shell	1.5
69	Screw Lock Assembly Stainless Steel (Male/hex. hole 2.0 head screw)	With Back Shell	1
70	Screw Lock Assembly Stainless Steel (Male/slotted head screw)		1
71	Screw Lock Assembly Brass (Male/hex. hole head screw)		1

TABLE 1(b) - MAXIMUM RATINGS

No.	Characteristic	Symbol	Maximum Ratings		Unit	Remarks
1	Operating Temperature Range	T _{op}	-55 to +125 (1)		°C	T _{amb}
2	Storage Temperature Range	T _{stg}	-55 to +125 (1)		°C	
3	Torque Value for Screws	T _{qe}	BRASS 3.3	S.S. 4.4	cm.daN	For Male

FIGURE 1 - PARAMETER DERATING INFORMATION

Not applicable.

FIGURE 2 - PHYSICAL DIMENSIONS
FIGURE 2(a) - MALE SCREW LOCK ASSEMBLIES
 Hex. Hole Head

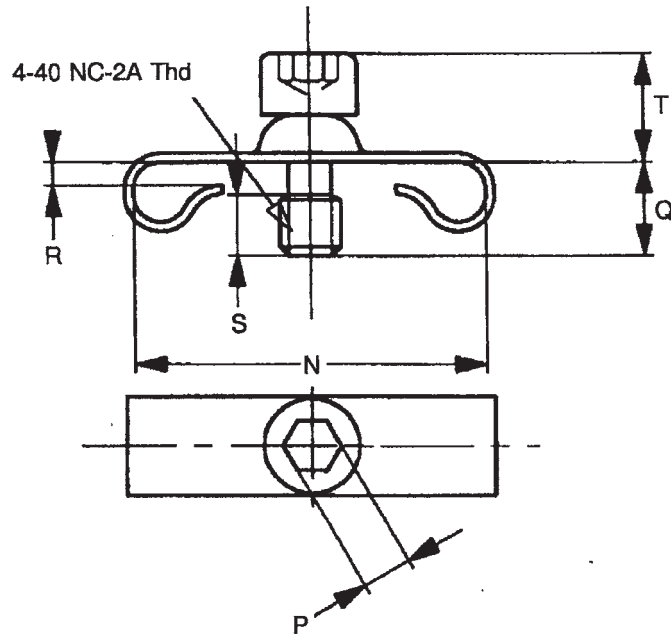

VARIANT		USE WITH SHELL SIZE	N		P (2) TYP.	Q		R		S MIN.	T MAX.
BRASS	S.S.		MIN.	MAX.		MIN.	MAX.	MIN.	MAX.		
		With Lightweight Backshell									
01	03	DA to DC: (P or S)	12.96	13.72	2.38	4.4	5.16	2.25	2.45	2.8	5.53
02	04	DD: (P or S)	15.75	16.26	2.38	4.4	5.16	2.25	2.45	2.8	5.53

NOTES:

1. All dimensions are in millimetres.
2. 2.00 for Variants 66 to 69.

FIGURE 2(b) - LIGHTWEIGHT BACKSHELL WITH SADDLE CLAMPS FOR STRAIN RELIEF

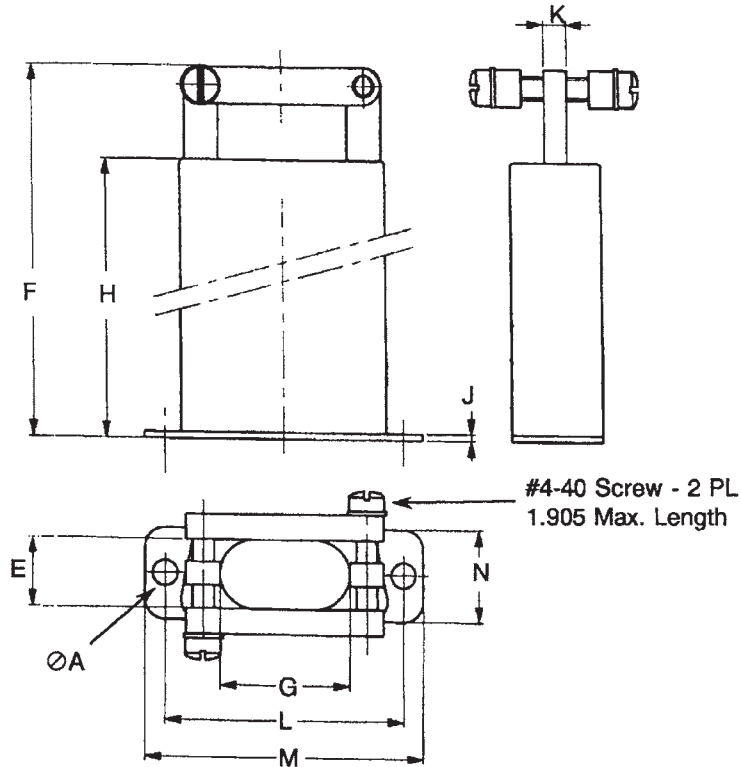

Shell Size	Variant	ØA		E		F		G		H	
		MIN	MAX	MIN	MAX	MIN	MAX	MIN	MAX	MIN	MAX
E	05	3.32	3.58	9.14	9.9	65.95	67.56	9.14	9.9	54.48	55.24
A	06	3.32	3.58	9.14	9.9	65.95	67.56	17.73	18.49	54.48	55.24
B	07	3.32	3.58	9.14	9.9	67.55	69.16	25.02	25.78	54.48	55.24
C	08	3.32	3.58	9.14	9.9	67.55	69.16	34.54	35.3	54.48	55.24
D	09	3.32	3.58	11.5	12.26	67.55	69.16	35.33	36.09	54.48	55.24

Shell Size	Variant	J		K	L		M		N	
		MIN	MAX		MIN	MAX	MIN	MAX	MIN	MAX
E	05	0.68	0.94	3.17	24.86	25.12	30.18	30.94	12.32	13.08
A	06	0.68	0.94	3.17	33.19	33.45	38.51	39.27	12.32	13.08
B	07	0.68	0.94	3.17	46.91	47.17	52.4	53.16	12.32	13.08
C	08	0.68	0.94	3.17	63.37	63.63	68.66	69.42	12.32	13.08
D	09	0.68	0.94	3.17	60.98	61.24	66.29	67.05	15.09	15.85

NOTES:

1. All dimensions are in millimetres.

FIGURE 2(c)- LIGHTWEIGHT D-SUB SHORTING CAN

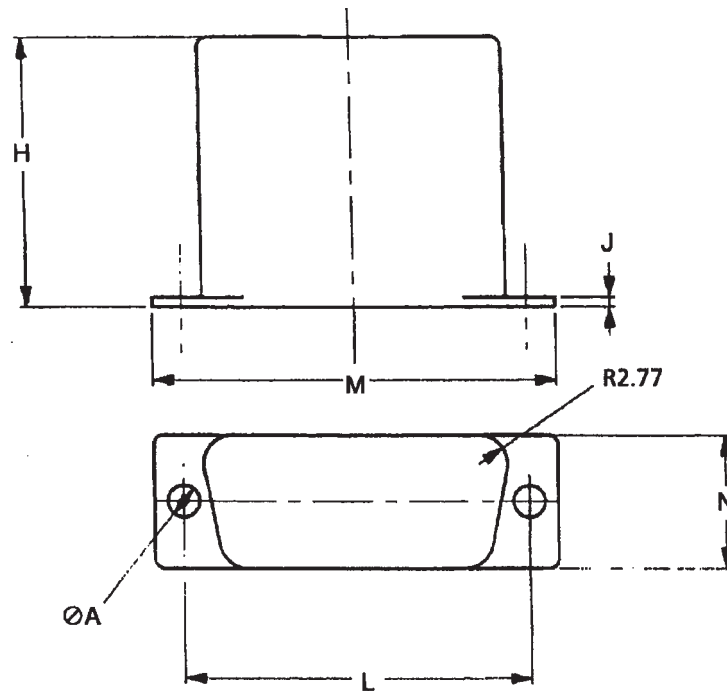

Shell Size	Variant	$\text{Ø}A$		H	J	L		M		N	
		MIN	MAX			MIN	MAX	MIN	MAX	MIN	MAX
E	10	3.92	4.04	25.4	0.9	24.86	25.12	30.18	30.94	12.32	13.08
A	11	3.92	4.04	25.4	0.9	33.19	33.45	38.51	39.27	12.32	13.08
B	12	3.92	4.04	25.4	0.9	46.91	47.17	52.4	53.16	12.32	13.08
C	13	3.92	4.04	25.4	0.9	63.37	63.63	68.66	69.42	12.32	13.08
D	14	3.92	4.04	25.4	0.9	60.98	61.24	66.29	67.05	15.09	15.85

NOTES:

1. All dimensions are in millimetres.

FIGURE 2(d) - EMI SHIELDED BACKSHELL - STRAIGHT CABLE OUTLET

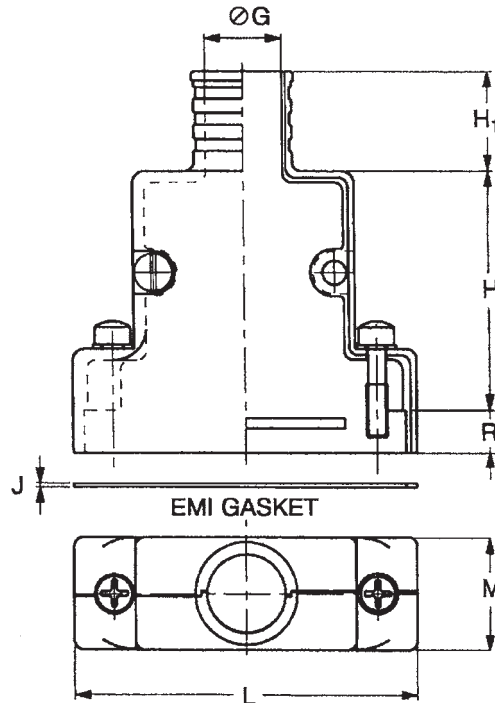

Shell Size	Variant		ØG		H MAX.	H ₁	J	M	
	FRONT MOUNT	REAR MOUNT	MIN	MAX				MIN	MAX
E	15	20	6.48	6.98	33.02	12.7	0.51	15.73	16.23
A	16	21	9.65	10.15	33.02	12.7	0.51	15.73	16.23
B	17	22	10.29	10.79	38.61	12.7	0.51	15.73	16.23
C	18	23	10.29	10.79	38.61	12.7	0.51	15.73	16.23
D	19	24	13.08	13.58	38.61	12.7	0.51	18.45	19.04

Shell Size	Variant		L		R			
	FRONT MOUNT	REAR MOUNT	MIN	MAX	FRONT MOUNT		REAR MOUNT	
					MIN	MAX	MIN	MAX
E	15	20	34.78	35.28	7.61	7.87	6.19	6.45
A	16	21	43.11	43.61	7.61	7.87	6.19	6.45
B	17	22	57	57.5	7.61	7.87	6.19	6.45
C	18	23	73.28	73.78	7.61	7.87	6.19	6.45
D	19	24	70.89	71.39	7.61	7.87	6.19	6.45

NOTES:

1. All dimensions are in millimetres.

FIGURE 2(e) - LIGHTWEIGHT SHIELDED BACKSHELL -90 ° LONGITUDINAL CABLE OUTLET

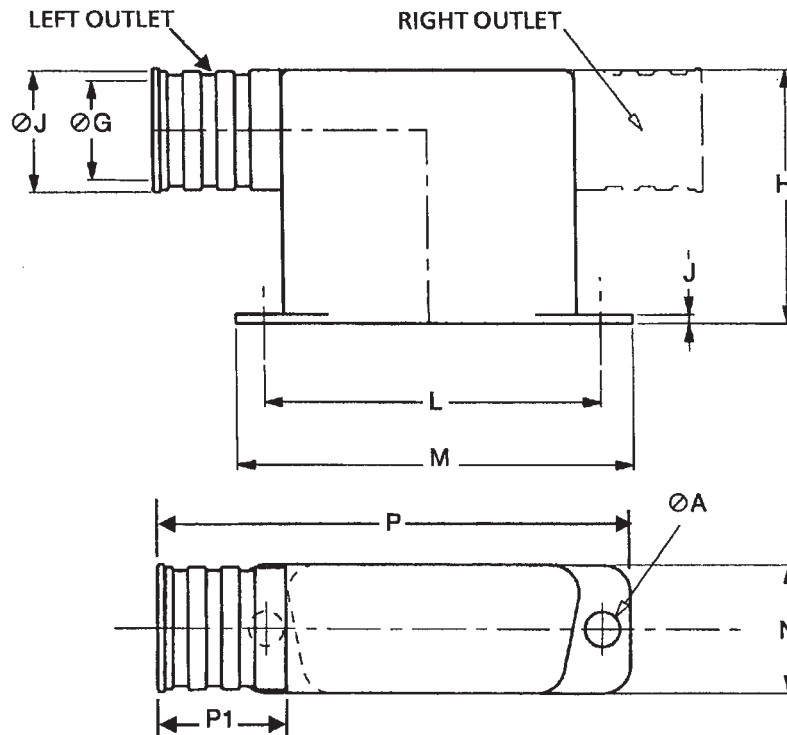

Shell Size	Variant		ØA		ØG		ØJ		H	
	Right Outlet	Left Outlet	MIN	MAX	MIN	MAX	MIN	MAX	MIN	MAX
E	25	30	3.91	4.03	6.47	7.23	8.51	9.26	24.64	26.16
A	26	31	3.91	4.03	9.65	10.41	11.68	12.44	24.64	26.16
B	27	32	3.91	4.03	10.28	11.04	12.32	13.08	24.64	26.16
C	28	33	3.91	4.03	10.28	11.04	12.32	13.08	24.64	26.16
D	29	34	3.91	4.03	13.05	13.81	15.08	15.84	24.64	26.16

Shell Size	Variant		J	L		M		N		P	P1
	Right Outlet	Left Outlet		MIN	MAX	MIN	MAX	MIN	MAX		
E	25	30	0.89	24.86	25.12	30.18	30.94	12.32	13.08	41.1	15
A	26	31	0.89	33.19	33.45	38.51	39.27	12.32	13.08	49.5	15
B	27	32	0.89	46.91	47.17	52.4	53.16	12.32	13.08	63.2	15
C	28	33	0.89	63.37	63.63	68.66	69.42	12.32	13.08	81	15
D	29	34	0.89	60.98	61.25	66.29	67.16	15.09	15.85	77.2	15

NOTES:

1. All dimensions are in millimetres.

FIGURE 2(f) - LIGHTWEIGHT SHIELDED BACKSHELL - STRAIGHT CABLE OUTLET

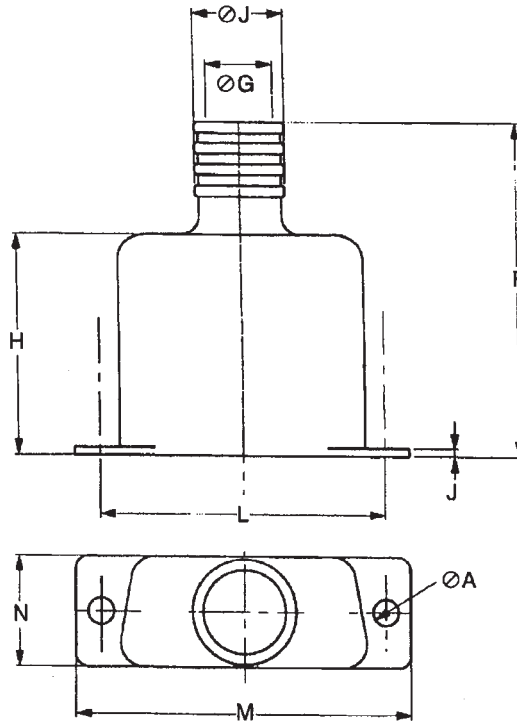

Shell Size	Variant	ØA		ØG		ØJ		F	H	J
		MIN	MAX	MIN	MAX	MIN	MAX			
E	35	3.91	4.03	6.47	7.23	8.51	9.27	38.10	25.4	0.89
A	36	3.91	4.03	9.65	10.41	11.68	12.44	38.10	25.4	0.89
B	37	3.91	4.03	10.28	11.04	12.32	13.08	38.10	25.4	0.89
C	38	3.91	4.03	10.28	11.04	12.32	13.08	38.10	25.4	0.89
D	39	3.91	4.03	13.05	13.81	15.08	15.84	38.10	25.4	0.89

Shell Size	Variant	L		M		N	
		MIN	MAX	MIN	MAX	MIN	MAX
E	35	24.86	25.12	30.18	30.94	12.32	13.08
A	36	33.19	33.45	38.51	39.27	12.32	13.08
B	37	46.91	47.17	52.4	53.16	12.32	13.08
C	38	63.37	63.63	68.66	69.42	12.32	13.08
D	39	60.98	61.25	66.29	67.16	15.09	15.85

NOTES:

1. All dimensions are in millimetres.

FIGURE 2(g) - LIGHTWEIGHT BACKSHELL, DUAL ENTRY BAND TERMINATION, 15 PIN

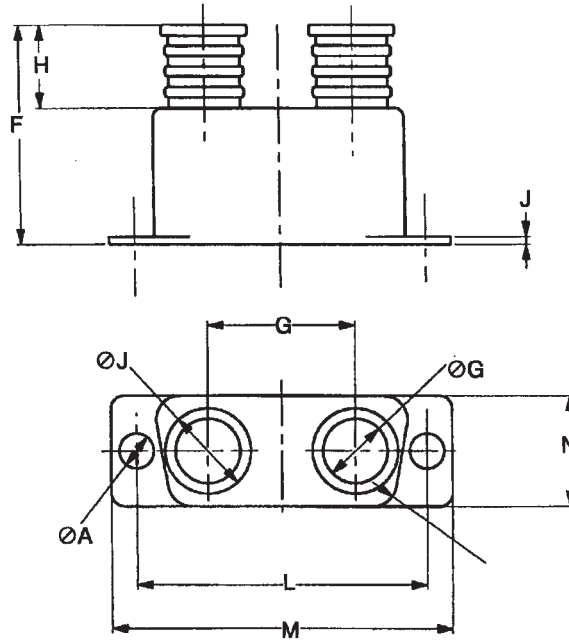

Shell Size	Variant	ØA		ØG		ØJ		F	G	H
		MIN.	MAX.	MIN.	MAX.	MIN.	MAX.			
A	40	3.92	4.04	6.99	7.75	9.4	10.16	25.4	16.89	9.65

Shell Size	Variant	J	L		M		N	
			MIN.	MAX.	MIN.	MAX.	MIN.	MAX.
A	40	0.9	33.07	33.57	38.51	39.27	12.32	13.08

NOTES:

1. All dimensions are in millimetres.

FIGURE 2(h) - CASTELLATED BACKSHELL

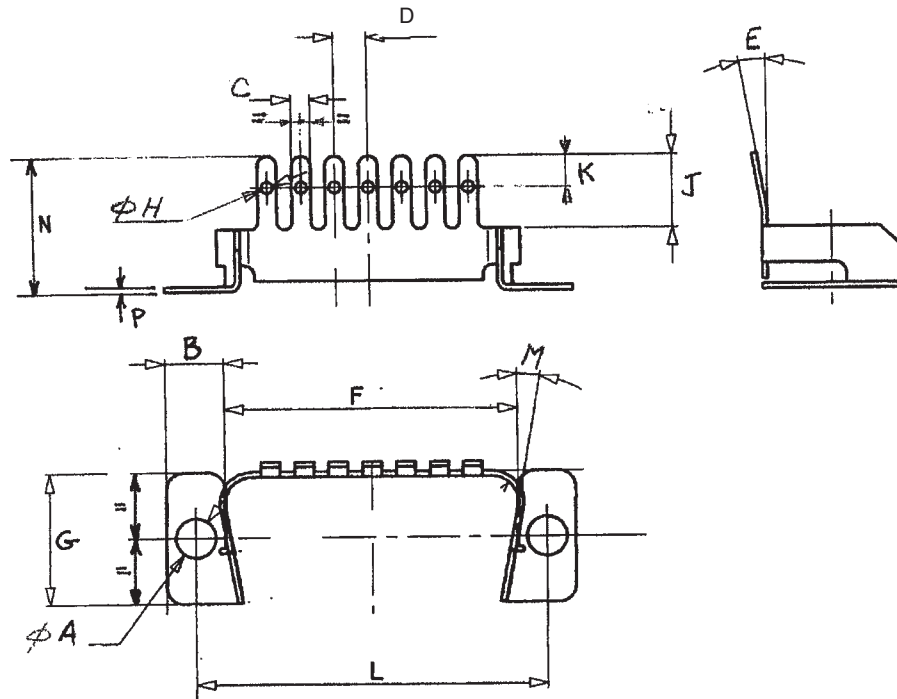

Shell Size	Variant	ØA		B		C		D		No. of Plates	E		F	
		MIN	MAX	MIN	MAX	MIN	MAX	MIN	MAX		MIN	MAX	MIN	MAX
E	41	3.7	3.9	5.25	5.45	1.7	1.9	3.1	3.3	5	10	15	19.45	19.75
A	42	3.7	3.9	5.25	5.45	1.7	1.9	3.1	3.3	7	10	15	27.7	28
B	43	3.7	3.9	5.25	5.45	1.7	1.9	3.1	3.3	11	10	15	41.35	41.65
C	44	3.7	3.9	5.25	5.45	1.7	1.9	3.1	3.3	16	10	15	57.95	58.25
D	45	3.7	3.9	5.25	5.45	1.7	1.9	3.1	3.3	15	10	15	55.6	55.9

Shell Size	Variant	G		ØH		J		K		L		M		N		P	
		MIN	MAX	MIN	MAX	MIN	MAX	MIN	MAX	MIN	MAX	MIN	MAX	MIN	MAX	MIN	MAX
E	41	12.6	12.8	0.9	1.1	6.8	7.2	2.75	3.25	24.86	25.12	9	11	12.3	13.7	0.4	0.6
A	42	12.6	12.8	0.9	1.1	6.8	7.2	2.75	3.25	33.19	33.45	9	11	12.3	13.7	0.4	0.6
B	43	12.6	12.8	0.9	1.1	6.8	7.2	2.75	3.25	46.91	47.17	9	11	12.3	13.7	0.4	0.6
C	44	12.6	12.8	0.9	1.1	6.8	7.2	2.75	3.25	63.37	63.63	9	11	12.3	13.7	0.7	0.9
D	45	15.3	15.5	0.9	1.1	6.8	7.2	2.75	3.25	60.98	61.24	9	11	12.3	13.7	0.7	0.9

NOTES:

1. All dimensions are in millimetres.
2. All angles are in degrees.

FIGURE 2(i) STRAIGHT LIGHTWEIGHT BACKSHELL ULTRA ELLIPTICAL BAND TERMINATION

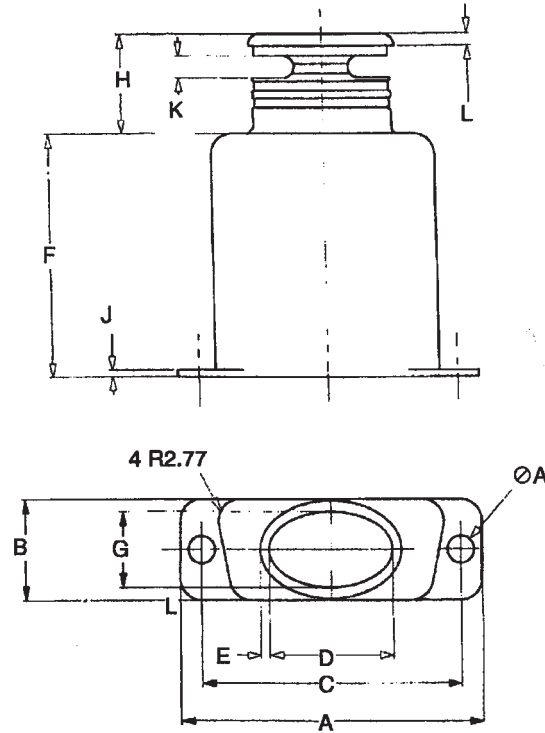

Shell Size	Variant	ØA		A		B		C		D	
		MIN.	MAX.	MIN.	MAX.	MIN.	MAX.	MIN.	MAX.	MIN.	MAX.
E	46	3.91	4.03	30.16	30.94	12.32	13.08	24.86	25.12	12.32	13.08
A	47	3.91	4.03	38.51	39.27	12.32	13.08	33.19	33.45	15.49	16.25
B	48	3.91	4.03	52.4	53.16	12.32	13.08	46.89	47.17	18.67	19.43
C	49	3.91	4.03	68.66	69.42	12.32	13.08	63.37	63.63	25.02	25.78
D	50	3.91	4.03	66.29	67.05	15.09	15.85	60.98	61.24	21.84	22.6

Shell Size	Variant	E	F	G	H	J	K	L
E	46	1.52	30.48	9.53	12.67	0.9	2.77	1.52
A	47	1.52	30.48	9.53	12.67	0.9	2.77	1.52
B	48	1.52	30.48	9.53	12.67	0.9	2.77	1.52
C	49	1.52	30.48	9.53	12.67	0.9	2.77	1.52
D	50	1.52	30.48	12.3	12.67	0.9	2.77	1.52

NOTES:

1. All dimensions are in millimetres.

FIGURE 2(j) - 45° LIGHTWEIGHT BACKSHELL ULTRA ELLIPTICAL BAND TERMINATION

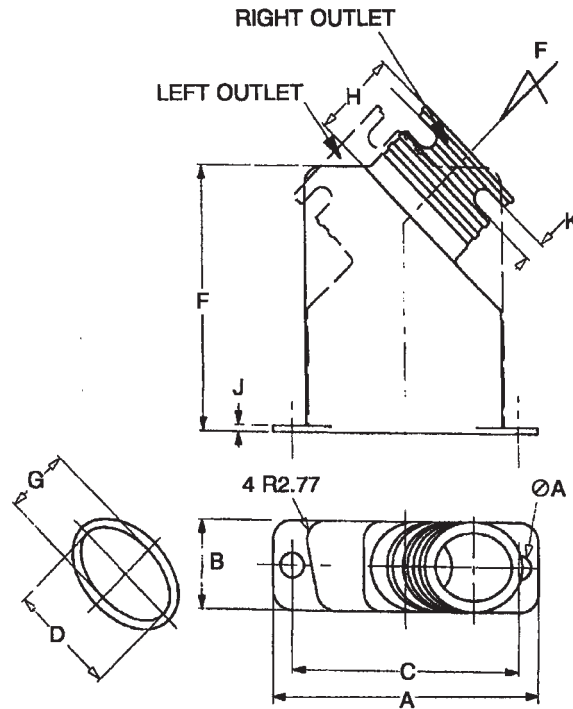

Shell Size	Variant		ØA		A		B		C		D	
	Right Outlet	Left Outlet	MIN.	MAX.	MIN.	MAX.	MIN.	MAX.	MIN.	MAX.	MIN.	MAX.
E	51	56	3.91	4.03	30.18	30.94	12.32	13.08	24.66	25.12	12.32	13.08
A	52	57	3.91	4.03	38.51	39.27	12.32	13.08	33.19	33.45	15.49	16.25
B	53	58	3.91	4.03	52.4	53.16	12.32	13.08	46.81	47.17	18.67	19.43
C	54	59	3.91	4.03	68.56	69.42	12.32	13.08	63.37	63.63	25.02	25.78
D	55	60	3.91	4.03	66.29	67.05	15.09	15.85	60.98	61.24	21.84	22.6

Shell Size	Variant		F	G	H	J	K
	Right Outlet	Left Outlet					
E	51	56	38.10	9.53	12.67	0.9	2.77
A	52	57	38.10	9.53	12.67	0.9	2.77
B	53	58	38.10	9.53	12.67	0.9	2.77
C	54	59	38.10	9.53	12.67	0.9	2.77
D	55	60	38.10	12.30	12.67	0.9	2.77

NOTES:

1. All dimensions are in millimetres.

FIGURE 2(k) - LIGHTWEIGHT D-SUB EXTRA SHORTING CAN

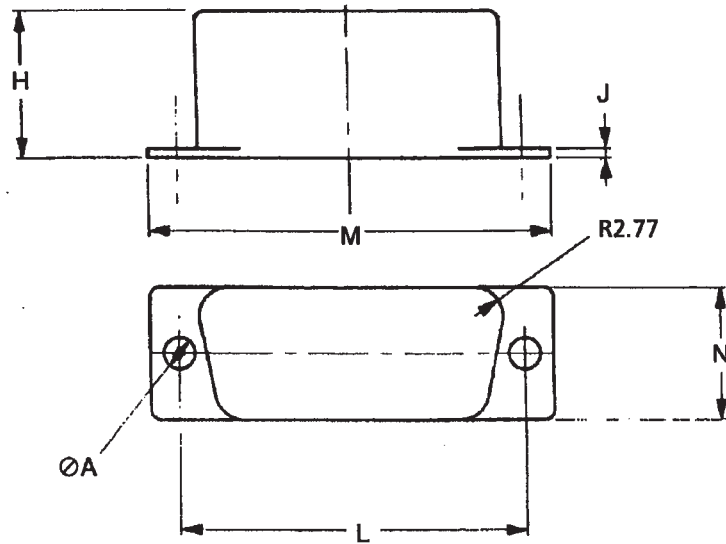

Shell Size	Variant	ØA		H	J	L		M		N	
		MIN.	MAX.			MIN.	MAX.	MIN.	MAX.	MIN.	MAX.
E	61	3.92	4.04	12.67	0.9	24.86	25.12	30.18	30.94	12.32	13.08
A	62	3.92	4.04	12.67	0.9	33.19	33.45	38.51	39.27	12.32	13.08
B	63	3.92	4.04	12.67	0.9	46.91	47.17	52.4	53.16	12.32	13.08
C	64	3.92	4.04	12.67	0.9	63.37	63.63	68.56	69.42	12.32	13.08
D	65	3.92	4.04	12.67	0.9	60.98	61.24	66.29	67.05	15.09	15.85

NOTES:

1. All dimensions are in millimetres.

**FIGURE 2(l) - MALE SCREW LOCK ASSEMBLY
SLOTTED HEAD**

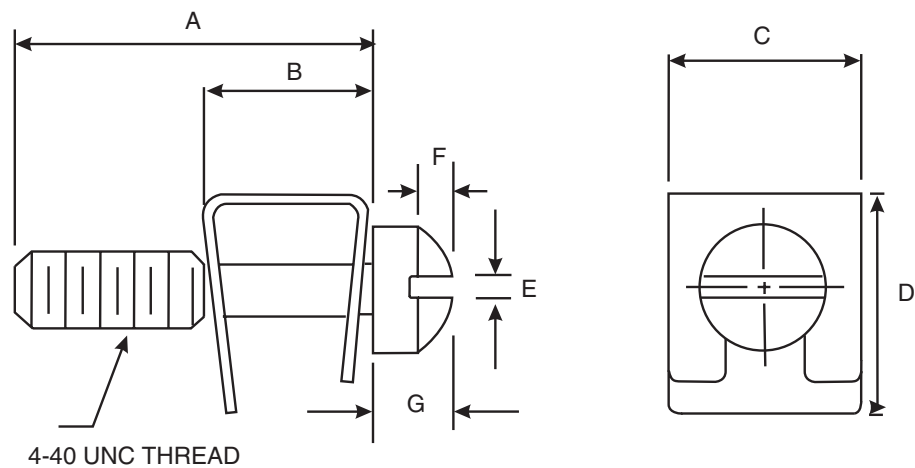

HEX. HEAD

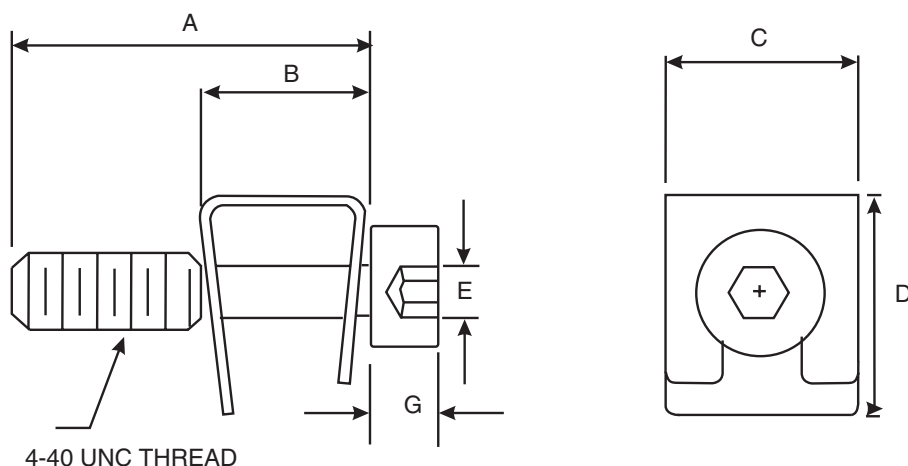

Variant	Head Type	A		B	C		D MAX.	E		F		G
		MIN.	MAX.		MIN.	MAX.		MIN.	MAX.	MIN.	MAX.	
70	Slotted	5.97	6.5	3.35	5.58	7.11	6.8	0.78	0.99	0.89	1.22	2.75
71	HEX	5.97	6.5	3.35	5.58	7.11	6.8	2.38 TYP.		-	-	2.85

NOTES:

1. All dimensions are in millimetres.

4. REQUIREMENTS

4.1 GENERAL

The complete requirements for procurement of the accessories specified herein are stated in this specification and ESCC Generic Specification No. 3401 for Connectors, Electrical, Circular and Rectangular. Deviations from the Generic Specification, applicable to this specification only, are listed in Para. 4.2.

Deviations from the applicable Generic Specification and this Detail Specification, formally agreed with specific Manufacturers on the basis that the alternative requirements are equivalent to the ESCC requirements and do not affect the components' reliability, are listed in the appendices attached to this specification.

4.2 DEVIATIONS FROM GENERIC SPECIFICATION

4.2.1 Deviations from Special In-Process Controls

- (a) Para. 5.2.2, Gold Plating Porosity: Not applicable.
- (b) Para. 5.2.3, Plating Thickness: Not applicable.

4.2.2 Deviations from Final Production Tests (Chart II)

Only the following tests shall be performed:

- (a) Para. 4.4, Marking.
- (b) Para. 9.6, Dimension Check.
- (c) Para. 9.7, External Visual Inspection. The magnification shall be X3.

4.2.3 Deviations from Burn-in and Electrical Measurements (Chart III)

Not applicable.

4.2.4 Deviations from Qualification Tests (Chart IV)

Not applicable.

4.2.5 Deviations from Lot Acceptance Tests (Chart V)

Not applicable.

4.3 MECHANICAL REQUIREMENTS

4.3.1 Dimension Check

The dimensions of the accessories specified herein shall be verified in accordance with the requirements set out in Para. 9.6 of ESCC Generic Specification No. 3401 and shall conform to those shown in Figure 2 of this specification.

4.3.2 Weight

The maximum weight of the accessories specified herein shall be as shown in Table 1(a) of this specification.

4.3.3 Torque Value

The torque value to be used for tightening the screws of the accessories specified herein shall be as mentioned in Table 1(b) of this specification.

4.4 MATERIALS AND FINISHES

The materials and finishes shall be as specified herein. Where a definite material is not specified, a material which will enable the components specified herein to meet the performance requirements of this specification shall be used. Acceptance or approval of any constituent material does not guarantee acceptance of the finished product.

4.4.1 Screw Lock Assemblies (Male and Female)

Potting shells and back-shells:

Material shall be brass plated with gold (0.7 μ m minimum) over copper (1 μ m minimum) or passivated stainless steel.

4.4.2 Lightweight Backshell

Material shall be aluminium alloy plated with gold (0.7 μ m minimum) over copper (1 μ m minimum).

4.4.3 Castellated Backshell

Material shall be copper alloy plated with gold (0.7µm minimum) over copper (1µm minimum).

4.4.4 EMI Gasket

Material shall be conductive silicone elastomer.

4.4.5 Magnetism Level

The allowable value of magnetism shall not exceed that specified for the relevant level (see Para. 4.5.3.1).

4.5 MARKING

4.5.1 General

The marking of components delivered to this specification shall be in accordance with the requirements of ESCC Basic Specification No. 21700 and the following paragraphs. When the component is too small to accommodate all of the marking as specified, as much as space permits shall be marked and the marking information, in full, shall accompany the component in its primary package.

The information to be marked and the order of precedence, shall be as follows:

- (a) The ESCC Component Number.
- (b) Characteristics.
- (c) Traceability Information.

4.5.2 The ESCC Component Number

Each components shall bear the ESCC Component Number which shall be constituted and marked as follows:

340107201B

- Detail Specification Number: 3401072
- Type Variant (See Table 1(a)): 01
- Testing Level: B

4.5.3 Characteristics

The characteristics to be marked in the following order of precedence are:

- (a) Magnetism Level.

4.5.3.1 *Magnetism Level (For all Variants, except Variants 03, 04, 68 to 71)*

The following code shall be used for magnetism level:

CODE	DEFINITION
NMB	Magnetism Level: ≤ 200 gamma

4.5.4 Traceability Information

Traceability information shall be marked in accordance with ESCC Basic Specification No. 21700.

4.6 ELECTRICAL MEASUREMENTS (TABLES 2 AND 3)

Not applicable.

4.7 BURN-IN AND ELECTRICAL MEASUREMENTS (TABLES 4 AND 5)

Not applicable.

4.8 ENVIRONMENTAL AND ENDURANCE TESTS (TABLE 6)

Not applicable.