



Pages 1 to 24

**CABLE, “SPACEWIRE”, ROUND, QUAD USING SYMMETRIC**

**CABLES, FLEXIBLE, -200 TO +180 °C**

**ESCC Detail Specification No. 3902/003**

Issue 2	June 2008
---------	-----------



Document Custodian: European Space Agency - see <https://escies.org>

**LEGAL DISCLAIMER AND COPYRIGHT**

European Space Agency, Copyright © 2008. All rights reserved.

The European Space Agency disclaims any liability or responsibility, to any person or entity, with respect to any loss or damage caused, or alleged to be caused, directly or indirectly by the use and application of this ESCC publication.

This publication, without the prior permission of the European Space Agency and provided that it is not used for a commercial purpose, may be:

- copied in whole, in any medium, without alteration or modification.
- copied in part, in any medium, provided that the ESCC document identification, comprising the ESCC symbol, document number and document issue, is removed.

**DOCUMENTATION CHANGE NOTICE**

(Refer to <https://escies.org> for ESCC DCR content)

DCR No.	CHANGE DESCRIPTION
204, 281	Specification upissued to incorporate technical and editorial changes per DCR.

**TABLE OF CONTENTS**

<b>1.</b>	<b><u>GENERAL</u></b>	<b>6</b>
1.1	Scope	6
1.2	Component Type Variants	6
1.3	Maximum Ratings	6
1.4	Parameter Derating Information (Figure 1)	6
1.5	Physical Dimensions and Characteristics	6
1.6	Functional Diagram	6
<b>2.</b>	<b><u>APPLICABLE DOCUMENTS</u></b>	<b>10</b>
<b>3.</b>	<b><u>TERMS, DEFINITIONS, ABBREVIATIONS, SYMBOLS AND UNITS</u></b>	<b>11</b>
<b>4.</b>	<b><u>REQUIREMENTS</u></b>	<b>11</b>
4.1	General	11
4.2	Deviations from Generic Specification	11
4.2.1	Deviations from Special In-Process Controls	11
4.2.2	Deviations from Final Production Tests (Chart II)	11
4.2.3	Deviations from Burn-in and Electrical Measurements (Chart III)	11
4.2.4	Deviations from Qualification Tests (Chart IV)	11
4.2.5	Deviations from Lot Acceptance Tests (Chart V)	12
4.3	Mechanical Requirements	12
4.3.1	Dimension Check	12
4.3.2	Weight	12
4.3.3	Adhesion of the Inner Conductor	12
4.4	Materials and Finishes	12
4.4.1	Construction of Round Cable	12
4.4.1.1	Generic Construction	12
4.4.1.2	Lay Length of Symmetric Cables	13
4.4.1.3	Lay Length of the Complete Cable	14
4.4.2	Inner Conductor	14
4.4.2.1	Material Characteristics	14
4.4.2.2	Stranding	14
4.4.3	Dielectric	14
4.4.3.1	Material	14
4.4.3.2	Construction	15
4.4.4	Filler	15
4.4.4.1	Material	15
4.4.4.2	Construction	15
4.4.5	Binder	15
4.4.5.1	Material	15
4.4.5.2	Construction	15
4.4.6	Shield	15
4.4.6.1	Material Characteristics	16
4.4.6.2	Construction	16
4.4.7	Jacket	16
4.4.7.1	Material Characteristics	16
4.4.7.2	Construction	16
4.4.8	Colours	16
4.5	Marking	17
4.5.1	General	17
4.5.2	The ESCC Component Number	17
4.5.3	Characteristics	17
4.5.4	Traceability Information	17

4.5.5	Additional Marking	17
4.6	Electrical Measurements	18
4.6.1	Electrical Measurements at Room Temperature	18
4.6.2	Electrical Measurements at High and Low Temperatures	18
4.6.3	Circuits for Electrical Measurements (Figure 4)	18
4.7	Burn-in Tests	18
4.8	Environmental and Endurance Tests (Charts IV and V of ESCC Generic Specification No. 3902)	18
4.8.1	Mechanical Properties of Conductor	18
4.8.2	Alternate Bending Resistance	18
4.8.3	Accelerated Ageing Stability	18
4.8.4	Cold Bend Test	19
4.8.5	Solderability	19
4.8.6	Corona Extinction Voltage	19
4.8.7	Resistance to Fluids	19
4.8.8	Flammability Resistance	19
4.8.9	Radiation Resistance	19
4.8.10	Outgassing	19
4.8.11	Long-term Ageing Test	19
4.8.12	Atomic Oxygen Resistance	19
4.8.13	Voltage Test	20
4.8.14	Characteristic Impedance	20
4.8.15	Attenuation	20
4.8.16	Structural Return Loss	20
4.8.17	Shielding Effectiveness	20
4.8.18	Time Delay	20
4.8.19	Time Delay Conductor Difference	21
APPENDIX A		23
APPENDIX B		24

## 1. GENERAL

### 1.1 SCOPE

This specification details the ratings, physical and electrical characteristics, test and inspection data for Cable, "spacewire", round, quad using symmetric cables, flexible, -200 to +180 °C. It shall be read in conjunction with ESCC Generic Specification No. 3902, the requirements of which are supplemented herein.

### 1.2 COMPONENT TYPE VARIANTS

Variants of the basic types of datalines specified herein, which are also covered by this specification are given in Table 1(a).

### 1.3 MAXIMUM RATINGS

The maximum ratings, which shall not be exceeded at any time during use or storage, applicable to the finished datalines specified herein, are as scheduled in Table 1(b).

### 1.4 PARAMETER DERATING INFORMATION (FIGURE 1)

The derating information applicable to the finished wires and cables specified herein is as follows:

- The maximum current for each wire used in a bundle shall be:-

$$I_{Bmax} = I_{max} \times \frac{29 - n}{28} \text{ (for } 1 \leq n \leq 15 \text{)}$$

$$I_{Bmax} = \frac{I_{max}}{2} \text{ (for } n > 15 \text{)}$$

where n = number of wires in the bundle;

- The temperature derating information is shown in Figure 1 with maximum current  $I_{max}$  for a single wire.
- The derating factors contained herein indicate maximum stress values and do not preclude further derating.

### 1.5 PHYSICAL DIMENSIONS AND CHARACTERISTICS

The physical dimensions and characteristics of the datalines specified herein, are shown in Table 1(a) and Figure 2 respectively.

### 1.6 FUNCTIONAL DIAGRAM

Not applicable.

**TABLE 1(a) - TYPE VARIANTS**

Variant	Z <sub>0</sub> (Ω)	AWG	Inner Conductor				Insul. Wire	Filler SC	Shield SC		Binder SC
			No. of Strands x Ø (mm)	Max. Ø (mm)	Nom. Sect. (mm <sup>2</sup> )	Max. dc Resist. (Ω/km)			Max. Ø (mm)	Ø (mm)	
01	100	28	7x0.126	0.39	0.089	256	1.2	1.0	BS	0.079	-
02	100	26	7x0.160	0.49	0.141	159	1.4	1.0	BS	0.079	0.076

Symmetric Cable Characteristics		Filler RC	Binder RC	Outer Shield RC		Round Cable Characteristics		Bend Radius
Max. Ø (mm)	Max. Weight (kg/km)	Ø (mm)	Nom. Ø (mm)	Constr.	Strand Ø (mm)	Max. Ø (mm)	Max. Weight (kg/km)	Min. (mm)
2.7	12	1.0	0.102	BS	0.102	7.5	85	45
3.1	15	1.4	0.102	BS	0.102	9	100	60

**TABLE 1(b) - MAXIMUM RATINGS**

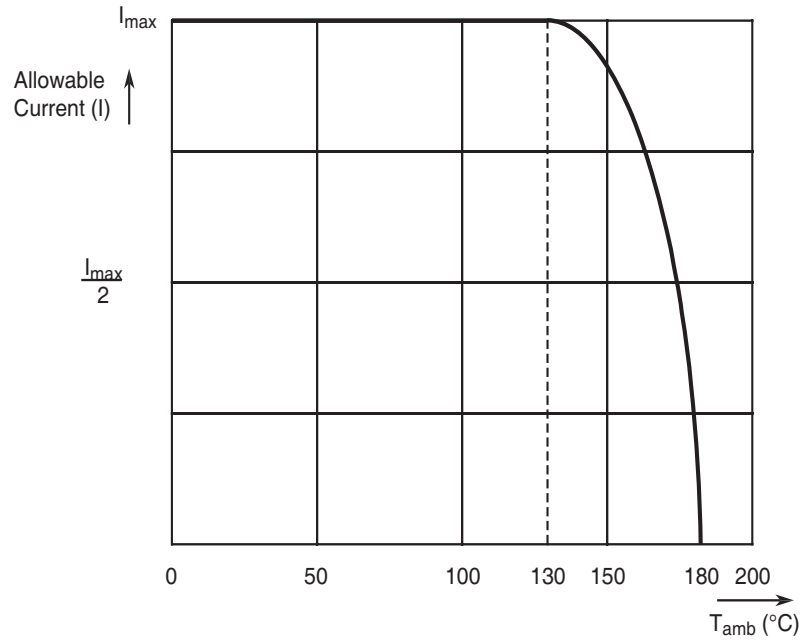
No.	Characteristics	Symbol	Maximum Rating	Unit	Remarks
1	Operating Voltage (Continuous)	V <sub>op</sub>	200	Vrms	-
2	Current Variant 01 Variant 02	I	1.5 2.5	A	
3	Operating Frequency	f <sub>M</sub>	400	MHz	10 metres
4	Data Transmission Rate Variant 01 Variant 02	DTR	100 200	Mbit/s	Assembly
5	Operating Temperature Range	T <sub>op</sub>	-200 to +180	°C	T <sub>amb</sub> Note 1
6	Storage Temperature Range	T <sub>stg</sub>	-200 to +180	°C	-
7	Soldering Temperature	T <sub>sol</sub>	+250	°C	Note 2

**NOTES:**

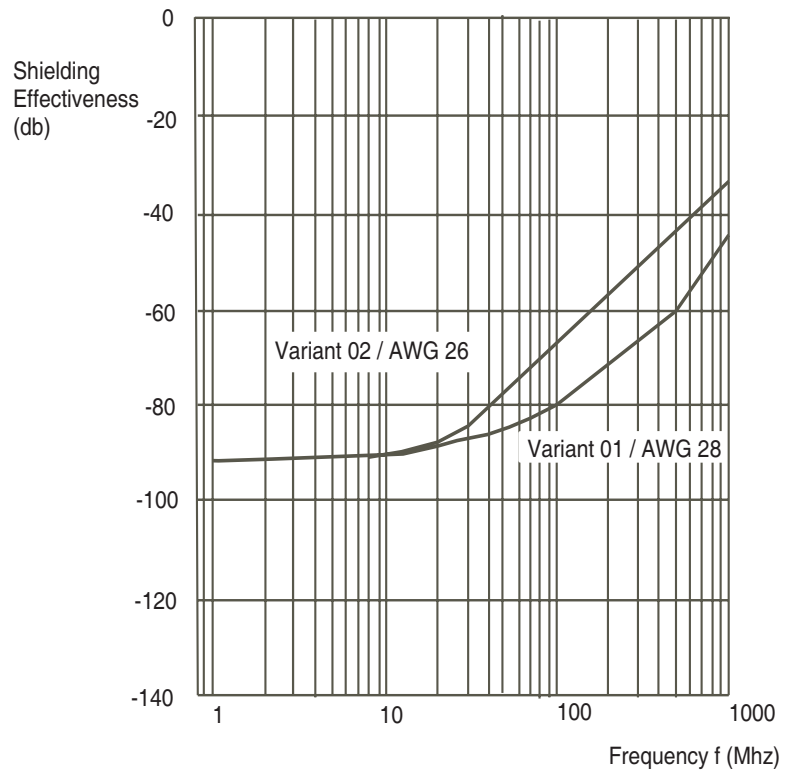
1. Precautions shall be taken such that the aggregate temperature of the datalines (ambient plus rise), due to power dissipation, does not exceed the maximum operating temperature..
2. For 5 seconds maximum.

**FIGURE 1- PARAMETER DERATING INFORMATION**

**FIGURE 1(a) - ALLOWABLE CURRENT VERSUS TEMPERATURE**

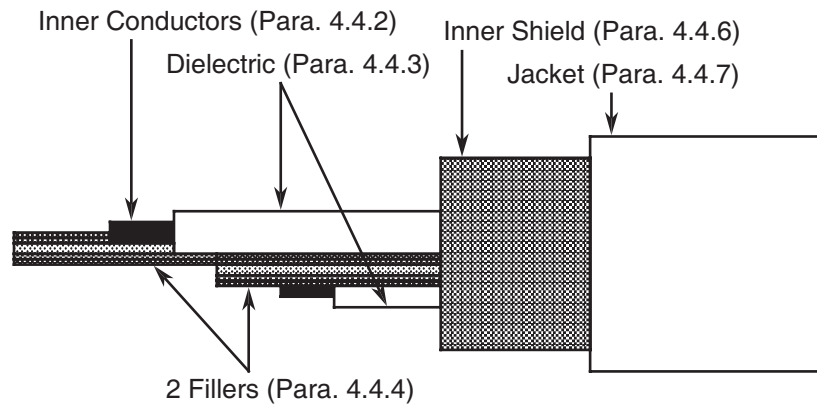


**FIGURE 1(b) - MINIMUM SHIELDING EFFECTIVENESS**





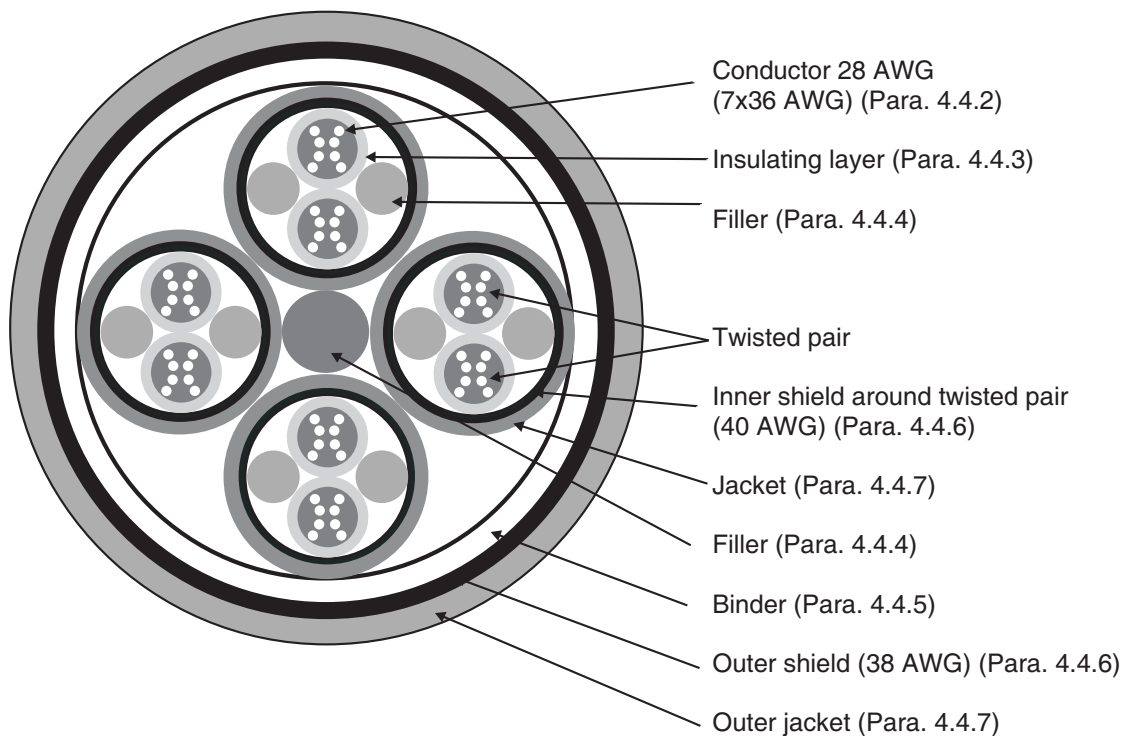
**FIGURE 2 - PHYSICAL CHARACTERISTICS**  
**FIGURE 2(a) - SINGLE SYMMETRIC CABLE - VARIANT 01**



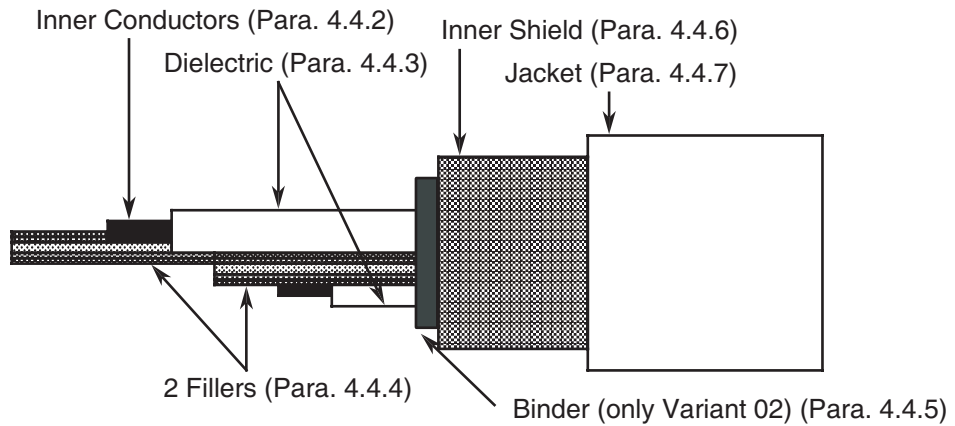
**NOTES:**

1. See Table 1(a) for dimensions.

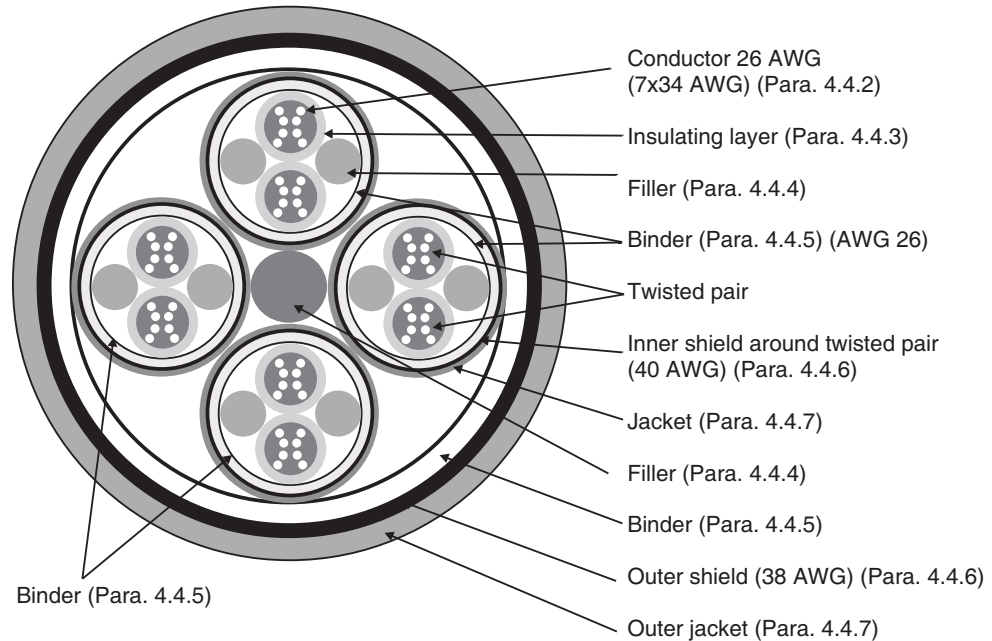
**FIGURE 2(b) - ROUND CABLE - VARIANT 01**



**FIGURE 2(c) - SINGLE SYMMETRIC CABLE - VARIANT 02**



**FIGURE 2(d) - ROUND CABLE - VARIANT 02**



**2. APPLICABLE DOCUMENTS**

The following documents form part of this specification and shall be read in conjunction with it:

- (a) ESCC Generic Specification No. 3902 for Cables, Coaxial, Radio Frequency, Flexible.
- (b) ESA PSS-01-301, Derating Requirements applicable to Electronic, Electrical and Electro-Mechanical Components.
- (c) MIL-C-17, Cables Radio Frequency, Flexible and Semirigid, General Specification for.
- (d) IEC Publication No. 96-1, Radio Frequency Cables, Part 1: General Requirements and Measuring

Methods.

### 3. **TERMS, DEFINITIONS, ABBREVIATIONS, SYMBOLS AND UNITS**

For the purpose of this specification, the terms, definitions, abbreviations, symbols and units specified in ESCC Basic Specification No. 21300 and ESCC Generic Specification No. 3902 shall apply. In addition, the following definitions shall be used:-

Cables	=	Datalines (general term).
Symmetrical Type	=	Balanced Shielded Lines.
BS	=	Braided Shield.
RC	=	Round Cable.

### 4. **REQUIREMENTS**

#### 4.1 **GENERAL**

The complete requirements for procurement of the finished round cable specified herein shall be as stated in this specification and ESCC Generic Specification No. 3902. Deviations from the Generic Specification, applicable to this Detail Specification only, are listed in Para. 4.2.

Deviations from the applicable Generic Specification and this Detail Specification, formally agreed with specific Manufacturers on the basis that the alternative requirements are equivalent to the ESCC requirements and do not affect the components' reliability, are listed in the appendices attached to this specification.

#### 4.2 **DEVIATIONS FROM GENERIC SPECIFICATION**

##### 4.2.1 **Deviations from Special In-Process Controls**

(a) Para. 5.3.1, Insulation Flaws (Spark Test): Shall be performed using 1.4kV at 3.0kHz.

##### 4.2.2 **Deviations from Final Production Tests (Chart II)**

- (a) Para. 9.7, Voltage Test: To be performed in accordance with Para. 4.8.13 of this specification.
- (b) Para. 9.10, Characteristic Impedance: To be performed in accordance with Para. 4.8.14 of this specification.
- (c) Para. 9.11, Attenuation: Shall not be performed.
- (d) Para. 9.12, Structural Return Loss: Shall not be performed.

##### 4.2.3 **Deviations from Burn-in and Electrical Measurements (Chart III)**

None.

##### 4.2.4 **Deviations from Qualification Tests (Chart IV)**

- (a) Para. 9.7, Voltage Test: To be performed in accordance with Para. 4.8.13 of this specification.
- (b) Para. 9.10, Characteristic Impedance: to be performed in accordance with Para. 4.8.14 of this specification.

- (c) Para. 9.11, Attenuation: Shall not be performed.
- (d) Para. 9.12, Structural Return Loss: Shall not be performed.
- (e) Shielding Effectiveness: Shall be performed in accordance with Para. 4.8.17 of this specification at any point in Chart IV.

4.2.5 Deviations from Lot Acceptance Tests (Chart V)

- (a) Para. 9.11, Attenuation: Shall not be performed.
- (b) Para. 9.12, Structural Return Loss: Shall not be performed.

4.3 MECHANICAL REQUIREMENTS

4.3.1 Dimension Check

The dimensions of the datalines specified herein shall be checked. They shall conform to those shown in Table 1(a), Figure 2 and Para. 4.4 of this specification (see the Table following for list of parameters to be checked).

4.3.2 Weight

The maximum weight of the datalines specified herein shall be measured in accordance with Para. 9.2 of ESCC Generic specification No. 3902 and shall be as specified in Table 1(a) of this specification.

4.3.3 Adhesion of the Inner Conductor

Minimum stripping force: 1N.

4.4 MATERIALS AND FINISHES

The materials and finishes shall be as specified herein. Where a definite material is not specified, a material which will enable the components specified herein to meet the performance requirements of this specification shall be used. Acceptance or approval of any constituent material does not guarantee acceptance of the finished product.

4.4.1 Construction of Round Cable

4.4.1.1 *Generic Construction*

The round cable with symmetric cables consists of four impedance controlled datalines with an overall shield and jacket. The datalines are constructed such that two conductors, each evenly centred within a dielectric, are twisted together with two fillers and then covered by a shield and jacket in accordance with Figure 2(a) and Figure 2(c). Variant 02 also includes a binder under the shield.

LIST OF PARAMETERS TO BE CHECKED

PARAMETER	TABLE 1(a)	FIGURE 2	PARA 4.4
<b>COMPOSITION</b>			
- Conductor Gauge	X		
- Number of Conductors	X		
- Shielding	X		

PARAMETER	TABLE 1(a)	FIGURE 2	PARA 4.4
- Number of Shields and Type		X	
- Jacket			X
<b>INNER CONDUCTOR</b>			
- Nature			X
- Outer Diameter	X		
- Number of Strands	X		
- Strand Diameter	X		
- Silver Thickness			X
- Length of Lay			X
<b>DIELECTRIC CORE</b>			
- Composition		X	X
- Nature			X
- Thickness	X		
- Concentricity			X
- Outer Diameter	X		
<b>SHIELDING</b>			
- Number of Strands			X
- Type of Shielding			X
- Strand Diameter	X		
- Tape Thickness			X
- Tape Overlap			X
- Silver Thickness			X
- Shielding Lay			X
- Shield Coverage			X
<b>FILLER</b>			
- Nature		X	X
- Outer Diameter	X		
<b>BINDER</b>			
- Nature		X	X
<b>JACKET</b>			
- Composition			X
- Thickness			X
- Outer Diameter	X		

4.4.1.2 Lay Length of Symmetric Cables

The lay length of all symmetric cables twisted together shall not be less than 12 times and not more than

16 times the outside diameter of the unshielded and unjacketed cable. This requirement will lead to the following lay length and/or twist per metre respectively.

Variant	Lay Length (mm)		Twists/m	
	Min.	Max.	Min.	Max.
01	24	32	32	41
02	27	35	29	37

4.4.1.3 *Lay Length of the Complete Cable*

Four sets of symmetric cables twisted together shall not be less than 12 times and not more than 16 times the outside diameter of two symmetric cables. This construction shall be the core to be covered by a binder and a braided shield, i.e. outer conductor. This construction is then covered by an outermost jacket in accordance with Figure 2(b) and Figure 2(c). Variant 02 also includes a binder under the shield.

Variant	Lay Length (mm)	
	Min.	Max.
01	57	77
02	74	98

4.4.2 Inner Conductor

4.4.2.1 *Material Characteristics*

All strands used in the manufacture of the conductor shall be silver-coated high strength copper alloy.

On silver-coated strands, the thickness of silver shall be 2µm minimum.

For high strength copper alloy conductors, the tensile characteristics shall be not less than 6% in elongation and 35kg/mm<sup>2</sup> in tensile strength.

For determination of the conductor resistance at +20°C, as mentioned in Para. 9.5 of ESCC Generic Specification No. 3902, the  $\alpha$  coefficient for copper alloy is 0.0035.

4.4.2.2 *Stranding*

The conductors shall be constructed of concentrically laid strands so as to produce a smooth and uniform conductor of circular cross-section and free from any high strands or other surface irregularities.

The length of lay of the external layer shall be not less than 8, nor more than 16 times the maximum conductor diameter specified in Table 1(a).

4.4.3 Dielectric

4.4.3.1 *Material*

Any dielectric material shall be virgin material, i.e. expanded, microporous PTFE or wrapped PTFE with

only those additives that are necessary for processing and pigmentation.

Material
Expanded, microporous PTFE

#### 4.4.3.2 *Construction*

The dielectric shall have a uniform cross-section throughout the length of the inner core or wire and the conductor shall be evenly centred in the dielectric.

The nominal diameter of the dielectric shall be in accordance with Table 1(a).

#### 4.4.4 Filler

Fillers shall be used so as to ensure a smooth and uniform diameter under the shielding in order to contribute to a uniform impedance over the length of the cable.

##### 4.4.4.1 *Material*

The filler material as used for the symmetric cables shall be expanded, microporous PTFE with only those additives necessary for processing.

The filler material as used for the round cable shell shall be PTFE with only the additives necessary for processing.

##### 4.4.4.2 *Construction*

The filler material shall be extruded or wrapped from tapes to the diameters as given in Table 1(a).

#### 4.4.5 Binder

Binders shall be used as appropriate over the symmetric cable core for Variant 02 only and over the completed round cable core for both variants.

##### 4.4.5.1 *Material*

The material shall be virgin, wrapped, expanded, microporous PTFE with only those additives necessary for processing.

##### 4.4.5.2 *Construction*

The material shall be wrapped with an overlap of 50% maximum.

#### 4.4.6 Shield

The terms "inner shield" and "outer shield" shall be used.

1 type of shield shall be used:-

- (a) Braided Shield (BS).

#### 4.4.6.1 *Material Characteristics*

All strands shall meet the requirements for silver-coated annealed copper as outlined in Para. 4.4.2.1 of this specification, but the thickness of silver shall be 2.5µm minimum.

Any strand shall show a 10% minimum elongation.

#### 4.4.6.2 *Construction*

The strand size shall be as specified in Table 1(a) of this specification.

##### (a) Braided Shield

The braided shield type shall be of push-back type and provide not less than 90% coverage. The coverage factor K is calculated as follows:-

$$K = (2F - F^2)$$

$$F = \frac{N \times P \times d}{\sin \alpha}$$

$$\tan \alpha = 2\Pi \frac{(D \times 2d) \times P}{C}$$

K = coverage (%).

N = number of strands.

d = shield strand diameter (mm).

α = angle of shield with cable axis in degrees.

D = effective diameter of core under shield (mm).

C = number of carriers.

P = serving pitch/mm.

#### 4.4.7 Jacket

The cable shall have jackets for each of the inner symmetric cables and an outer jacket for the complete round cable.

##### 4.4.7.1 *Material Characteristics*

The material shall be a layer of extruded fluoropolymer PFA, with only those additives that are necessary for processing and pigmentation.

##### 4.4.7.2 *Construction*

The PFA shall be extruded such that the construction underneath is centred evenly within the jacket. The wall thickness for the inner jackets shall be 0.2mm maximum, and for the outer jacket 0.25mm maximum.

#### 4.4.8 Colours

The dielectric material, the fillers and binders shall be white.



The jacket colour for Variant 01 shall be white.

The jacket colour for Variant 02 shall be blue.

#### 4.5 MARKING

##### 4.5.1 General

The marking of all spools of finished datalines delivered to this specification shall be in accordance with the requirements of ESCC Basic Specification No. 21700. Each spool shall be marked in respect of:-

- (a) The ESCC Component Number.
- (b) Characteristics
- (c) Traceability Information.
- (d) Additional Marking.

##### 4.5.2 The ESCC Component Number

Each components shall bear the ESCC Component Number which shall be constituted and marked as follows:

390200301B

- Detail Specification Number: 3902003
- Type Variant (See Table 1(a)): 01
- Testing Level: B

##### 4.5.3 Characteristics

The characteristics shall show the length(s) of the finished round cable wound on each spool and shall be marked as follows:-

100m

- Length in Metres (see Note): 100
- Symbol for Metres: m

N.B.

Whenever the length is less than 100 metres, insert a zero in the first block (example: 075m) If more than 1 length of finished round cable is wound on a spool, the characteristics of each length shall be marked as above.

##### 4.5.4 Traceability Information

Each spool shall be marked in respect of Traceability information in accordance with ESCC Basic Specification No. 21700.

##### 4.5.5 Additional Marking

Each spool shall bear the Manufacturer's Quality Control Inspector's stamp.

4.6 ELECTRICAL MEASUREMENTS

4.6.1 Electrical Measurements at Room Temperature

The parameters to be measured in respect of electrical characteristics are scheduled in Table 2. Unless otherwise specified these measurements shall be performed at  $T_{amb}=+22\pm3^{\circ}C$ .

4.6.2 Electrical Measurements at High and Low Temperatures

Not applicable.

4.6.3 Circuits for Electrical Measurements (Figure 4)

Not applicable

4.7 BURN-IN TESTS

Not applicable.

4.8 ENVIRONMENTAL AND ENDURANCE TESTS (CHARTS IV AND V OF ESCC GENERIC SPECIFICATION NO. 3902)

4.8.1 Mechanical Properties of Conductor

As detailed in Paras. 4.4.2.1 and 4.4.6.1 of this specification.

4.8.2 Alternate Bending Resistance

The applied weights and bending diameter for alternate bending resistance are given in Table A.

Number of cycles: 500 minimum.

TABLE A- ALTERNATE BENDING RESISTANCE, LOAD AND DIAMETER

Type	$Z_0$ ( $\Omega$ )	Weight (kg)	Bending Diameter (mm)
RC Variant 01	100	1.3	70
RC Variant 02	100	1.5	90

4.8.3 Accelerated Ageing Stability

Ageing temperature :  $+200\pm5^{\circ}C$

Shrinkage/Protrusion : See Table B.

Wrap Test : Mandrel diameters as per Table C.

TABLE B - SHRINKAGE/PROTRUSION

Type	$Z_0$ ( $\Omega$ )	Max. Shrinkage or Protrusion (mm)
RC	100	2

Maximum Capacitance Change : +7%

4.8.4 Cold Bend Test

Chamber temperature :  $-80\pm 5^{\circ}\text{C}$   
Mandrel diameter and load : See Table C.

TABLE C - COLD BEND TEST, MANDREL DIAMETERS AND LOADS

Type	$Z_0$ ( $\Omega$ )	Weight (kg)	Mandrel Diameter (mm)
RC Variant 01	100	1.3	70
RC Variant 02	100	1.5	90

4.8.5 Solderability

No particular conditions are applicable.

4.8.6 Corona Extinction Voltage

As per Table 2.

4.8.7 Resistance to Fluids

No particular conditions are applicable.

4.8.8 Flammability Resistance

No particular conditions are applicable.

4.8.9 Radiation Resistance

- (a) Insulation Resistance: Shall stay within specified limits, see Table 2.
- (b) Voltage Test: Shall stay within specified limits, see Table 2.
- (c) Maximum Capacitance Change: +7%.
- (d) Maximum Impedance Change: +7%.
- (e) Corona extinction voltage: Shall stay within specified limits, see Table 2.

4.8.10 Outgassing

No particular conditions are applicable.

4.8.11 Long-term Ageing Test

Ageing temperature:  $+180\pm 5^{\circ}\text{C}$ .

- (a) Insulation Resistance: Shall stay within specified limits, see Table 2.
- (b) Voltage Test: Shall stay within specified limits, see Table 2.
- (c) Maximum Capacitance Change: +7%.
- (d) Maximum Impedance Change: +7%.
- (e) Corona extinction voltage: Shall stay within specified limits, see Table 2.

4.8.12 Atomic Oxygen Resistance

The outer surface of the datalines is resistant against atomic oxygen and shall be verified in accordance

with the requirements of the ESCC Executive.

4.8.13 Voltage Test

The voltage test shall be performed in accordance with ESCC Generic specification No. 3902, Para. 9.7, with the exception that the whole length of each produced lot shall be tested with the dc voltages specified in Table 2 for a minimum of 1 minute.

4.8.14 Characteristic Impedance

The characteristic impedance of all symmetric cables shall be measured according to MIL-C-17, Para. 4.8.7 using a time domain reflectometer (TDR), with a symmetrical input/output. all measurements shall be performed on cables with a minimum length of 3 metres.

Impedance reference shall be defined before test.

4.8.15 Attenuation

Not applicable.

4.8.16 Structural Return Loss

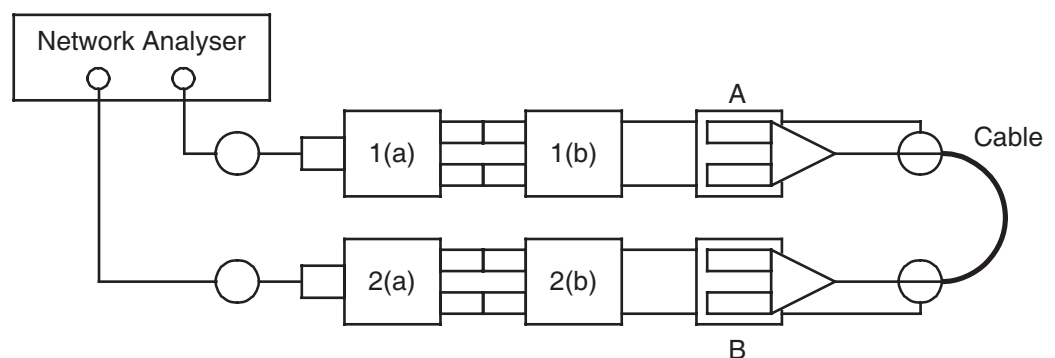
Not applicable.

4.8.17 Shielding Effectiveness

The shielding effectiveness of the cables shall be determined. Since the shielding effectiveness or transfer impedance respectively is a characteristic which is dependent only on constructional parameters, its performance shall be measured only once during qualification in accordance with IEC 96-1, 46 A 142 and Figure 1(b) of this specification.

4.8.18 Time Delay

The time delay of the balanced shielded lines shall be measured in accordance with Table 2 using a network analyser on a minimum length of 3 metres.



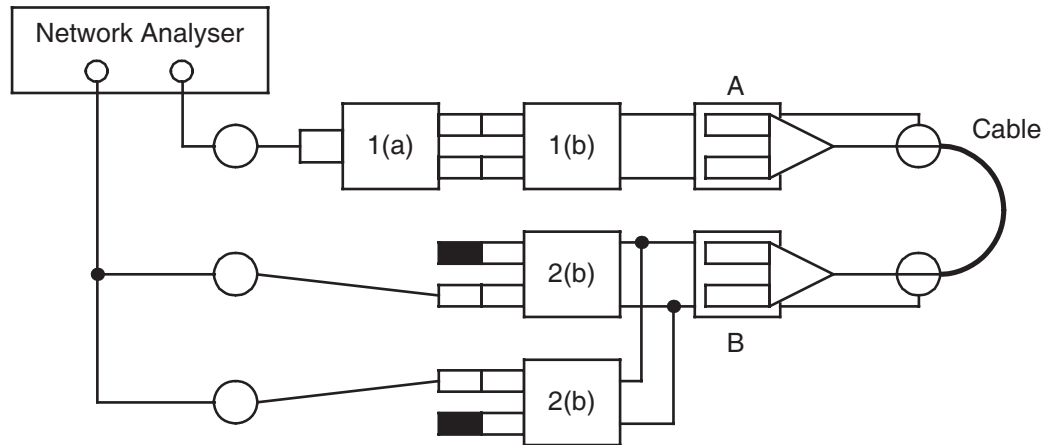
- 1(a) and 2(a) : Symmetrical Transformers (1x50Ω to 2 x 50Ω)
- 1(b) and 2(b) : Impedance Matching (50Ω to 75/100/120Ω)
- A and B : Clamp connection

A symmetrical 50Ω signal will be produced by the network analyser (0.3 - 3000 MHz), split into 2 symmetrical signals 1(a) and transformed to the desired impedance of the balanced shielded line under test 1(b). After the signal has passed the cable under measurement, the signal will be impedance matched to 50Ω 2(b) and retransformed to a single signal 2(a).

The specimen cable is connected to input and output A and B, and the time delay between input and output is measured and displayed by the network analyser.

4.8.19 Time Delay Conductor Difference

The time delay conductor difference of the balanced shielded lines shall be measured in accordance with Table 2 using a network analyser on a minimum length of 3 metres.



- 1(a) : Symmetrical Transformers (1x50Ω to 2 x 50Ω)
- 1(b) and 2(b) : Impedance Matching (50Ω to 75/100/120Ω)
- A and B : Clamp connection

A symmetrical 50Ω signal will be produced by the network analyser (0.3 - 3000 MHz), split into 2 symmetrical signals 1(a) and transformed to the desired impedance of the balanced shielded line under test 1(b). After the signal has passed 1 line of the symmetrical cable, connected to input A and output B, the signal will be impedance matched to 50Ω 2(b). The 1 open port of the impedance matching pad will be terminated by 50Ω.

This procedure shall be repeated for the second single line of the symmetrical cable, and both values shall be compared, with the conductor difference displayed by the network analyser.

**TABLE 2 - ELECTRICAL MEASUREMENTS AT ROOM TEMPERATURE  
ROUND CABLES**

Type	ESCC Generic Specification No. 3902						
	Para. 9.6	Para. 9.6	Para. 9.7	Para. 9.9		Para. 9.10	Para. 9.20
	No. 1	No. 2	No. 3	No. 4		No. 5	No. 6
	Characteristic Diel. Strength of Inner Jacket (kVac)	Characteristic Diel. Strength of Outer Jacket (kVac)	Characteristic Voltage Test (Diel. Core) (kVdc)	Characteristic Capacitance (Max.) (pF/m)		Characteristic Impedance (Ω)	Characteristic Corona Extinction Voltage (Vac)
Cond. - Cond.				Cond. - Shield			
RC Variant 01	1.5	2.0	1.4	50	90	100±6	500
RC Variant 02	1.5	2.0	1.4	45	79	100±6	500

No.	Characteristic	ESCC Generic 3902	This Specification	Limits
7	Inner Conductor Resistance	Para. 9.5	-	See Table 1(a)
8	Insulation Resistance	Para. 9.8	-	5000MΩ x km
9	Shielding Effectiveness	-	Para. 4.8.17	See Figure 1(b)

SYMMETRIC CABLES

This Specification		
Para. 4.8.18	Para. 4.8.19	Para. 4.8.19
No. 10	No. 11	No. 12
Characteristic Time Delay (Max.) (ns/m)	Characteristic Conductor Time Delay Difference (Max.) (ns/m) Per Pair	Characteristic Conductor Time Delay Difference (Max.) (ns/m) Pair to Pair
4.3	0.08	0.13

**APPENDIX A****AGREED DEVIATIONS FOR W.L. GORE AND CO. GmbH (D)**

ITEMS AFFECTED	DESCRIPTION OF DEVIATIONS
Para. 4.2.2	Para. 9.14, Anthony and Brown Test: May be performed as the last test in Chart II.
Paras. 4.4.3.1, 4.4.4.1 and 4.4.5.1	Expanded microporous PTFE tape shall be GORE-TEX®.

**APPENDIX B****AGREED DEVIATIONS FOR AXON' CABLE (F)**

ITEMS AFFECTED	DESCRIPTION OF DEVIATIONS
Para. 4.4.8	White insulator layer and blue insulator layer will be used for the two wires of the single symmetric cable. Different filler colours will be used to differentiate each single symmetric cable of the round cable: white, blue, red, black
Para. 4.4.7.2	The wall thickness for the inner jackets shall be 0.15mm maximum and for the outer jacket 0.5mm maximum.