



Pages 1 to 15

**CAPACITOR FILTERS, T-TYPE, ELECTROMAGNETIC  
INTERFERENCE SUPPRESSION, NON-HERMETICALLY  
SEALED, SURFACE MOUNT**

**BASED ON TYPE SFCMS 35 TYPE T**

**ESCC Detail Specification No. 3008/035**

Issue 1	July 2005
---------	-----------



Document Custodian: European Space Agency - see <https://escies.org>

### **LEGAL DISCLAIMER AND COPYRIGHT**

European Space Agency, Copyright © 2005. All rights reserved.

The European Space Agency disclaims any liability or responsibility, to any person or entity, with respect to any loss or damage caused, or alleged to be caused, directly or indirectly by the use and application of this ESCC publication.

This publication, without the prior permission of the European Space Agency and provided that it is not used for a commercial purpose, may be:

- copied in whole, in any medium, without alteration or modification.
- copied in part, in any medium, provided that the ESCC document identification, comprising the ESCC symbol, document number and document issue, is removed.

**DOCUMENTATION CHANGE NOTICE**

(Refer to <https://escies.org> for ESCC DCR content)

DCR No.	CHANGE DESCRIPTION

<b>1.</b>	<b><u>GENERAL</u></b>	<b>5</b>
1.1	Scope	5
1.2	Component Type Variants	5
1.3	Maximum Ratings	5
1.4	Parameter Derating Information	5
1.5	Physical Dimensions	5
1.6	Functional Diagram	5
<b>2.</b>	<b><u>APPLICABLE DOCUMENTS</u></b>	<b>5</b>
<b>3.</b>	<b><u>TERMS, DEFINITIONS, ABBREVIATIONS, SYMBOLS AND UNITS</u></b>	<b>5</b>
<b>4.</b>	<b><u>REQUIREMENTS</u></b>	<b>7</b>
4.1	General	7
4.2	Deviations from Generic Specification	7
4.2.1	Deviations from Special In-process Controls	7
4.2.2	Deviations from Final Production Tests (Chart II)	7
4.2.3	Deviations from Burn-in and Electrical Measurements (Chart III)	7
4.2.4	Deviations from Qualification Tests (Chart IV)	8
4.2.5	Deviations from Lot Acceptance Tests (Chart V)	8
4.3	Mechanical Requirements	8
4.3.1	Dimension Check	8
4.3.2	Weight	8
4.3.3	Robustness of Terminations	8
4.3.4	Solderability	9
4.4	Materials and Finishes	9
4.4.1	Case	9
4.4.2	Lead Material and Finish	9
4.5	Marking	9
4.5.1	General	9
4.5.2	The ESCC Component Number	9
4.5.3	Traceability Information	9
4.6	Electrical Measurements	10
4.6.1	Electrical Measurements at Room Temperature	10
4.6.2	Electrical Measurements at High and Low Temperatures	10
4.6.3	Circuits for Electrical Measurements (Figure 4)	10
4.7	Burn-in Tests	10
4.7.1	Parameter Drift Values	10
4.7.2	Conditions for Burn-in	10
4.7.3	Electrical Circuit for Burn-in (Figure 5)	10
4.8	Environmental and Endurance Tests (Charts IV and V of ESCC Generic Specification No. 3008)	12
4.8.1	Measurements and Inspections on Completion of Environmental Tests	12
4.8.2	Measurements and Inspections at Intermediate Points During Endurance Tests	12
4.8.3	Measurements and Inspections on Completion of Endurance Tests	12
4.8.4	Conditions for Operating Life	12
4.8.5	Electrical Circuit for Operating Life (Figure 5)	12

## 1. GENERAL

### 1.1 SCOPE

This specification details the ratings, physical and electrical characteristics, test and inspection data for a Capacitor Filter, T-Type, Electromagnetic Interference Suppression, Non-hermetically Sealed, Surface Mount, based on type SFCMS 35 Type T. It shall be read in conjunction with ESCC Generic Specification No. 3008, the requirements of which are supplemented herein.

### 1.2 COMPONENT TYPE VARIANTS

Not applicable, see Para. 4.5.2.

### 1.3 MAXIMUM RATINGS

The maximum ratings, which shall not be exceeded at any time during use or storage, applicable to the components specified herein, are as scheduled in Table 1(b).

### 1.4 PARAMETER DERATING INFORMATION

Not applicable.

### 1.5 PHYSICAL DIMENSIONS

The physical dimensions of the components specified herein are shown in Figure 2.

### 1.6 FUNCTIONAL DIAGRAM

The functional diagram of the components specified herein is shown in Figure 3.

## 2. APPLICABLE DOCUMENTS

The following documents form part of this specification and shall be read in conjunction with it:

- (a) ESCC Generic Specification No. 3008 for Capacitors and Capacitor Filters, Feedthrough.
- (b) MIL-STD-202, Test Methods for Electronic and Electrical Component Parts.

## 3. TERMS, DEFINITIONS, ABBREVIATIONS, SYMBOLS AND UNITS

For the purpose of this specification, the terms, definitions, abbreviations, symbols and units specified in ESCC Basic Specification No. 21300 shall apply.

### Table 1(a) - Type Variants

Not applicable.

**Table 1(b) - MAXIMUM RATINGS**

No.	Characteristics	Symbol	Maximum Ratings	Unit	Remarks
1	Rated DC Voltage	$U_R$	50	V	Note 1
2	Voltage Drop	$V_{dr}$	200	mV	
3	DC Resistance	$R_S$	2	m $\Omega$	
4	DC and Low Frequency Current	$I_R$	10	A	
5	Operating Temperature Range	$T_{op}$	-55 to +125	$^{\circ}\text{C}$	$T_{amb}$
6	Storage Temperature Range	$T_{stg}$	-55 to +125	$^{\circ}\text{C}$	
7	Soldering Temperature	$T_{sol}$	+260	$^{\circ}\text{C}$	Note 2

**NOTES:**

1. The addition of DC applied voltage and ripple voltage shall never exceed the rated DC voltage.
2. Duration 6 seconds maximum and the same termination, or the case, shall not be resoldered until 3 minutes have elapsed.

**FIGURE 1- PARAMETER DERATING INFORMATION**

Not applicable.

**FIGURE 2 - PHYSICAL DIMENSIONS**

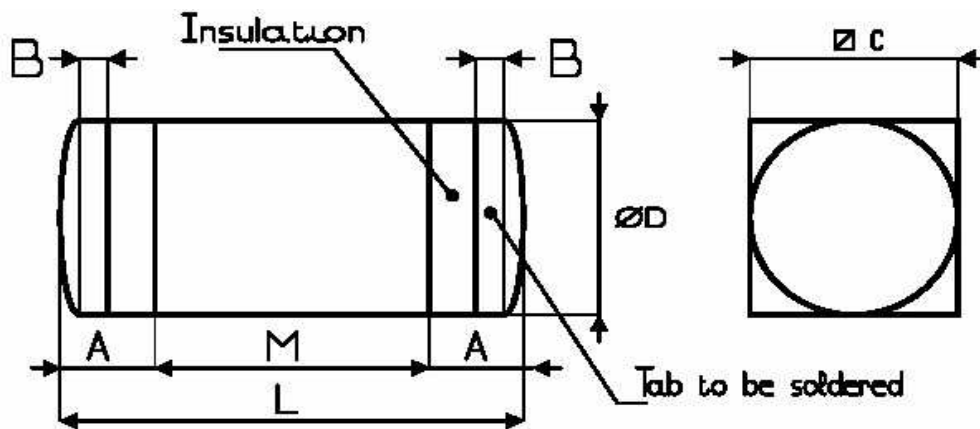

Symbol	Dimensions (mm)		Remarks
	Min	Max	
A	1.9	2.6	
B	0.7	0.9	
C	3.5	3.6	Note 1
$\varnothing D$	3.5	3.6	Note 2
L	11.3	12.7	
M	7.4	7.6	

**NOTES:**

1. This dimension applies to the square-section case (Ground), over dimension M. One of the four

- faces shall bear marking in accordance with Para. 4.5.
2. This dimension (diameter) applies to both the tab termination and the insulation.

**FIGURE 3 - FUNCTIONAL DIAGRAM**

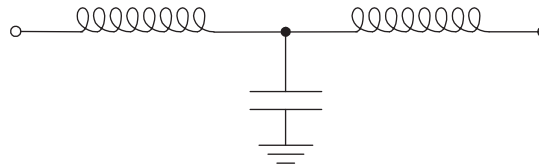

## 4. REQUIREMENTS

### 4.1 GENERAL

The complete requirements for procurement of the components specified herein are stated in this specification and ESCC Generic Specification No. 3008 for Capacitors and Capacitor Filters, Feedthrough. Deviations from the Generic Specification, applicable to this specification only, are detailed in Para. 4.2.

Deviations from the applicable Generic Specification and this Detail Specification, formally agreed with specific Manufacturers on the basis that the alternative requirements are equivalent to the ESCC requirements and do not affect the components' reliability, are listed in the appendices attached to this specification.

### 4.2 DEVIATIONS FROM GENERIC SPECIFICATION

#### 4.2.1 Deviations from Special In-process Controls

None.

#### 4.2.2 Deviations from Final Production Tests (Chart II)

- (a) Para. 9.4.1.5, Voltage Drop: Shall be performed as a DC resistance measurement in accordance with MIL-STD-202, Method 303.
- (b) Para. 9.2, Rapid Change of Temperature: The Components may not be mounted.
- (c) Para. 9.3, Vibration: Not applicable.

#### 4.2.3 Deviations from Burn-in and Electrical Measurements (Chart III)

- (a) Para. 9.4.1.5, Voltage Drop: Shall be performed as a DC resistance measurement in accordance with MIL-STD-202, Method 303.
- (b) Paras. 9.4.3, Electrical Measurements at High and Low Temperature and 9.4.4, Electrical Measurements at Room Temperature: Insertion Loss is considered as destructive and the parts so tested cannot be delivered as flight models. Therefore, these tests shall be performed at the end of Chart III and parts rejected during External Visual Inspection or Radiographic Inspection, but electrically acceptable after Burn-in, may be used.

#### 4.2.4 Deviations from Qualification Tests (Chart IV)

- (a) Para. 9.4.1.5, Voltage Drop: Shall be performed as a DC resistance measurement in accordance with MIL-STD-202, Method 303.
- (b) Para. 9.12, Accelerated Damp Heat: Voltage Proof and Insertion Loss shall not be performed.
- (c) Para. 9.14, Robustness of Terminations: Only test Ua is applicable.
- (d) Para. 9.15, Immersion: Not applicable.
- (e) Para. 9.17, Resistance to Soldering Heat: May be performed prior to Para. 9.11, Vibration. Capacitance is performed in lieu of Insertion Loss at Final Measurements.
- (f) Para. 9.18, Solderability: May be performed prior to Para. 9.10, Shock.
- (g) Para. 9.19, Operating Life (Intermediate and End Data Points): Insertion Loss shall not be performed.

#### 4.2.5 Deviations from Lot Acceptance Tests (Chart V)

- (a) Para. 9.4.1.5, Voltage Drop: Shall be performed as a DC resistance measurement in accordance with MIL-STD-202, Method 303.
- (b) Para. 9.14, Robustness of Terminations: Only test Ua is applicable.
- (c) Para. 9.15, Immersion: Not applicable.
- (d) Para. 9.18, Solderability: May be performed prior to Para. 9.10, Shock.
- (e) Para. 9.19, Operating Life (Intermediate and End Data Points): Insertion Loss shall not be performed.

### 4.3 MECHANICAL REQUIREMENTS

#### 4.3.1 Dimension Check

The dimensions of the components specified herein shall be verified in accordance with the requirements set out in Para. 9.5 of ESCC Generic Specification No. 3008 and they shall conform to those shown in Figure 2 of this specification.

#### 4.3.2 Weight

The maximum weight of the components specified herein shall be 2 grammes.

#### 4.3.3 Robustness of Terminations

The requirements for the robustness of terminations tests are specified in Para. 9.14 of the Generic Specification and below.

##### Add to Para. 9.14.1 of the Generic Specification

For surface mount components, capacitors shall be mounted on a suitable substrate. After mounting, examination shall be made for good tinning as evidenced by flowing of the solder with wetting of the terminations.

##### Add to Para. 9.14.2 (for method Ua) of the Generic Specification

For surface mount components, a force of 10N shall be applied on the terminations normal to the length of the case and in a plane parallel to the substrate, duration = 10s.

##### Add to Para. 9.14.3 of the Generic Specification

For surface mount components, there shall be no evidence of damage or loosening of the components from the substrate.



#### 4.3.4 Solderability

The requirements for solderability testing are specified in Para. 9.18 of the Generic Specification and below.

The test shall be carried out in accordance with IEC 68-2-20 standard with the following conditions:

- Test Ta, Method 1
- Temperature:  $+235\pm 3^{\circ}\text{C}$
- Immersion time:  $3\pm 0.3$  seconds

The terminations shall be immersed to their interface with the insulation (see Figure 2).

#### 4.4 MATERIALS AND FINISHES

The materials and finishes shall be as specified herein. Where a definite material is not specified, a material which will enable the components specified herein to meet the performance requirements of this specification shall be used. Acceptance or approval of any constituent material does not guarantee acceptance of the finished product.

##### 4.4.1 Case

The case shall be silver plated brass.

##### 4.4.2 Lead Material and Finish

The tab material shall be brass with tin-lead layer (lead>95%) with Nickel and Silver underplating.

#### 4.5 MARKING

##### 4.5.1 General

The marking of components delivered to this specification shall be in accordance with the requirements of ESCC Basic Specification No. 21700 and the following paragraphs. When the component is too small to accommodate all of the marking specified, as much as space permits shall be marked and the marking information, in full, shall accompany the component in its primary package.

The information to be marked and the order of precedence, shall be as follows:

- (a) The ESCC Component Number.
- (b) Traceability Information

##### 4.5.2 The ESCC Component Number

The ESCC Component Number shall be constituted and marked as follows:

300803501B

- Detail Specification Reference: 3008035
- Component Type Variant Number: 01
- Testing Level (B or C, as applicable)

##### 4.5.3 Traceability Information

Each component shall be marked in respect of traceability information in accordance with the

requirements of ESCC Basic Specification No. 21700.

4.6 ELECTRICAL MEASUREMENTS

4.6.1 Electrical Measurements at Room Temperature

The parameters to be measured at room temperature are scheduled in Table 2. Unless otherwise specified, measurements shall be performed at  $T_{amb}=+22\pm 3^{\circ}C$ .

4.6.2 Electrical Measurements at High and Low Temperatures

The parameters to be measured at high and low temperatures are scheduled in Table 3. Measurements shall be performed at  $T_{amb}+125(+0-5)^{\circ}C$  and  $-55(+5-0)^{\circ}C$  respectively.

4.6.3 Circuits for Electrical Measurements (Figure 4)

Not applicable.

4.7 BURN-IN TESTS

4.7.1 Parameter Drift Values

The parameter drift values applicable to Burn-in are as specified in Table 4 of this specification. Unless otherwise stated, measurements shall be performed at  $T_{amb}=+22\pm 3^{\circ}C$ . The parameter drift values ( $\Delta$ ) applicable to the parameters scheduled shall not be exceeded. In addition to these drift value requirements for a given parameter, the appropriate limit values specified in Table 2 shall not be exceeded.

4.7.2 Conditions for Burn-in

The requirements for Burn-in are specified in Section 7 of ESCC Generic Specification No. 3008. The conditions for Burn-in shall be as specified in Table 5(a) of this specification.

4.7.3 Electrical Circuit for Burn-in (Figure 5)

Not applicable.

**Table 2 - ELECTRICAL MEASUREMENTS AT ROOM TEMPERATURE - DC PARAMETERS**

No.	Characteristics	Symbol	ESCC 3008 Test Method	Test Conditions	Limits		Unit
					Min	Max	
1	DC Resistance	$R_S$	MIL-STD-202 Method 303	-	-	2	m $\Omega$
2	Voltage Proof	VP	Para. 9.4.1.2	-	125	-	V
3	Insulation Resistance	Ri	Para. 9.4.1.3	Para. 9.4.1.3	1000	-	M $\Omega$

**Table 2 - ELECTRICAL MEASUREMENTS AT ROOM TEMPERATURE - AC PARAMETERS**

No.	Characteristics	Symbol	ESCC 3008 Test Method	Test Conditions	Limits		Unit
					Min	Max	
4	Insertion Loss, Note 4	$I_{L1}$	Para. 9.4.1.4	f=10MHz, Note 2	25	-	dB
5	Insertion Loss	$I_{L2}$	Para. 9.4.1.4	f=50MHz, Note 1	39	-	dB
6	Insertion Loss, Note 4	$I_{L3}$	Para. 9.4.1.4	f=100MHz, Note 2	45	-	dB
7	Insertion Loss	$I_{L4}$	Para. 9.4.1.4	f=500MHz, Note 1	59	-	dB

No.	Characteristics	Symbol	ESCC 3008 Test Method	Test Conditions	Limits		Unit
					Min	Max	
8	Insertion Loss, Note 4	$I_{L5}$	Para. 9.4.1.4	f=1GHz, Note 2	65	-	dB
9	Capacitance	C	Para. 9.4.1.1	f=1kHz±100Hz V=0.1 to 1.2Vrms	8	-	nF

**Table 3 - ELECTRICAL MEASUREMENTS AT HIGH AND LOW TEMPERATURES**

No.	Characteristics	Symbol	ESCC 3008 Test Method	Test Conditions	Limits		Unit
					Min	Max	
3	Insulation Resistance Note 3	$R_i$	Para. 9.4.1.3	Para. 9.4.1.3 $T_{amb}=+125(+0 -5)^\circ\text{C}$	100	-	MΩ
4	Insertion Loss Note 4	$I_{L1}$	Para. 9.4.1.4	f=10MHz, No current	25	-	dB
6	Insertion Loss Note 4	$I_{L3}$	Para. 9.4.1.4	f=100MHz, No current	45	-	dB
8	Insertion Loss Note 4	$I_{L5}$	Para. 9.4.1.4	f=1GHz, No current	65	-	dB

**NOTES TO TABLES 2 AND 3:**

1. Measurements at this frequency to be made only during Chart IV testing.
2. Measurements at rated current to be made only during Chart IV testing. Measurements without load current to be made during Charts III and V. NB: not performed during Chart II testing.
3. This measurement must be carried out at the end of the Burn-in in accordance with Para. 9.23 of ESCC Generic Specification No. 3008 and shall not be carried out again.
4. Measurements at Room, High and Low Temperatures to be made on a sample of 5 parts per lot. If one or more failures occur then another 5 samples shall be tested. If one or more of the additional 5 samples fails then the lot shall be rejected. The samples shall be mounted on a suitable substrate prior to measurements. See also Para. 4.2.3.

**FIGURE 4 - CIRCUITS FOR ELECTRICAL MEASUREMENTS**

Not applicable.

**Table 4 - PARAMETER DRIFT VALUES**

No.	Characteristics	Symbol	Spec. and/or Test Method	Test Conditions	Change Limits ( $\Delta$ )	Unit
9	Capacitance Change	$\Delta C/C$	As per Table 2	As per Table 2	±10	%

**Table 5(a) - CONDITIONS FOR BURN-IN**

No.	Characteristics	Symbol	Condition	Unit
1	Ambient Temperature	$T_{amb}$	+125(+0 -3)	°C
2	Test Voltage	$V_T$	100 Note 1	V

**NOTES:**

1. Applied between one tab and the case.

**Table 5(b) - CONDITIONS FOR OPERATING LIFE**

No.	Characteristics	Symbol	Condition	Unit
1	Ambient Temperature	T <sub>amb</sub>	+125(+0 -3)	°C
2	Test Voltage	V <sub>T</sub>	100 Note 1	V
3	Rated Current	I <sub>R</sub>	10	A

**NOTES:**

1. Applied between one tab and the case.

**FIGURE 5 - ELECTRICAL CIRCUIT FOR BURN-IN AND OPERATING LIFE**

Not applicable.

4.8 ENVIRONMENTAL AND ENDURANCE TESTS (CHARTS IV AND V OF ESCC GENERIC SPECIFICATION NO. 3008)

4.8.1 Measurements and Inspections on Completion of Environmental Tests

The parameters to be measured and inspections to be performed on completion of environmental tests are scheduled in Table 6. Unless otherwise stated, the measurements shall be performed at T<sub>amb</sub>=+22±3°C.

4.8.2 Measurements and Inspections at Intermediate Points During Endurance Tests

The parameters to be measured and inspections to be performed at intermediate points during endurance tests are scheduled in Table 6. Unless otherwise stated, the measurements shall be performed at T<sub>amb</sub>=+22±3°C.

4.8.3 Measurements and Inspections on Completion of Endurance Tests

The parameters to be measured and inspections to be performed on completion of endurance tests are scheduled in Table 6. Unless otherwise stated, the measurements shall be performed at T<sub>amb</sub>=+22±3°C.

4.8.4 Conditions for Operating Life

The requirements for operating life test are specified in Section 9 of ESCC Generic Specification No. 3008. The conditions for operating life testing shall be as specified in Table 5(b) of this specification.

4.8.5 Electrical Circuit for Operating Life (Figure 5)

Not applicable.

**Table 6 - MEASUREMENTS AND INSPECTIONS ON COMPLETION OF ENVIRONMENTAL TESTS AND AT INTERMEDIATE POINTS AND ON COMPLETION OF ENDURANCE TESTING**

No.	ESCC Generic Spec. No. 3008		Measurements and Inspections		Symbol	Limits		Unit
	Environmental and Endurance Tests (1)	Test Methods and Conditions	Identification	Conditions		Min	Max	
01	Seal Test (Hermetically Sealed)	Para. 9.6	Not applicable					
02	External Visual Inspection	Para. 9.7	<u>Final Measurements</u> Visual Inspection	ESCC No. 20500	-	-	-	-
03	Temperature Rise	Para. 9.9	Temperature Rise	Rated Current (3)	-	-	25	°C

No.	ESCC Generic Spec. No. 3008		Measurements and Inspections		Symbol	Limits		Unit	
	Environmental and Endurance Tests (1)	Test Methods and Conditions	Identification	Conditions		Min	Max		
04	Shock	Para. 9.10	<u>Measurements during Tests</u>	100% U <sub>R</sub> (2) applied No Open or Short Circuits >100µs					
			<u>Final Measurements</u>						
			Visual Examination	No Mechanical Damage	-	-	-	-	
			Insertion Loss	Table 2 Items 4 to 8	I <sub>L</sub>	Table 2	-	dB	
05	Vibration	Para. 9.11	<u>Measurements during Tests</u>	Current (7) and 100% U <sub>R</sub> (2) applied No Open or Short Circuits >100µs					
			<u>Final Measurements</u>						
			Visual Examination	No Mechanical Damage	-	-	-	-	
			Insertion Loss	Table 2 Items 4 to 8	I <sub>L</sub>	Table 2	-	dB	
06	Accelerated Damp Heat	Para. 9.12 and Para. 4.2.4 of this spec.	<u>Final Measurements</u>	After recovery of 4 to 24 hours					
			Visual Examination	No corrosion or obliteration of marking	-	-	-	-	
			Insulation Resistance	Table 2 Item 3	R <sub>i</sub>	(5)	-	MΩ	
07	Low Air Pressure	Para. 9.13	<u>Measurements during Tests</u>	during last 5 minutes					
			Voltage Proof	Table 2 Item 2	VP	125% U <sub>R</sub> (2)	-	V	
			Visual Examination	No breakdown, flashover, deformation or seepage	-	-	-	-	
			<u>Final Measurements</u>						
			Visual Examination	No breakdown, flashover, deformation or seepage	-	-	-	-	
08	Robustness of Terminations	Para. 9.14 and Paras. 4.2.4, 4.2.5 and 4.3.3 of this spec.	<u>Final Measurements</u>						
			Visual Examination	No damage	-	-	-	-	
			DC Resistance	Table 2 Item 1	R <sub>S</sub>	-	Table 2	mΩ	
09	Immersion	Para. 9.15 and Paras. 4.2.4 and 4.2.5 of this spec.	Not applicable						
10	Overload	Para. 9.16		140% of Rated Current (3) for 15 mins min.					
			<u>Final Measurements</u>						

No.	ESCC Generic Spec. No. 3008		Measurements and Inspections		Symbol	Limits		Unit
	Environmental and Endurance Tests (1)	Test Methods and Conditions	Identification	Conditions		Min	Max	
			Insulation Resistance	Table 2 Item 3	R <sub>i</sub>	Table 2	-	MΩ
			DC Resistance	Table 2 Item 1	R <sub>S</sub>	-	Table 2	mΩ
			Visual Examination	No damage	-	-	-	-
11	Resistance to Soldering Heat	Para. 9.17 and Para. 4.2.4(b) of this spec.	<u>Final Measurements</u>	After recovery of 1 to 2 hrs				
			Visual Examination	No damage	-	-	-	-
			Insulation Resistance	Table 2 Item 3	R <sub>i</sub>	Table 2	-	MΩ
			Capacitance	Table 2 Item 9	C	Table 2	-	pF
12	Solderability	Para. 9.18 and Para. 4.3.4 of this spec	<u>Final Measurements</u>					
			Visual Examination	IEC No. 68-2-20 Para. 4.6.4, 4.7.4 or 4.9.3	-	-	-	-
13	Operating Life	Para. 9.19 and Paras. 4.2.4 and 4.2.5 of this spec.	During tests	Open or short Circuit		-	-	
			<u>Initial Measurements</u>					
			Voltage Drop	ESCC 3008, Para. 9.4.1.5	V <sub>dr</sub>	-	(6)	V
			Voltage Proof	Table 2, Item 2	VP	90% U <sub>R</sub> (2)	-	V
			Insulation Resistance	Table 2, Item 3	R <sub>i</sub>	Table 2	-	MΩ
			Capacitance	Table 2, Item 9	C	Table 2	-	pF
			<u>Intermediate Measurements</u>					
			Insulation Resistance	Table 3, Item 3	R <sub>i</sub>	Table 3	-	MΩ
				After 24 hours recovery				
			Voltage Drop	ESCC 3008, Para. 9.4.1.5	V <sub>dr</sub>	-	(6)	V
			Voltage Proof	Table 2, Item 2	VP	90% U <sub>R</sub> (2)	-	V
			Insulation Resistance	Table 2, Item 3	R <sub>i</sub>	(4)	-	MΩ
			Capacitance	Table 2, Item 9	C	Table 2	-	pF
			Capacitance Change	Table 2, Item 9	ΔC/C	-	Table 4	%
			<u>Final Measurements</u>					
			Insulation Resistance	Table 3, Item 3	R <sub>i</sub>	Table 3	-	MΩ
				After 24 hours recovery				

No.	ESCC Generic Spec. No. 3008		Measurements and Inspections		Symbol	Limits		Unit
	Environmental and Endurance Tests (1)	Test Methods and Conditions	Identification	Conditions		Min	Max	
			Voltage Drop	ESCC 3008, Para. 9.4.1.5	$V_{dr}$	-	(6)	V
			Voltage Proof	Table 2, Item 2	VP	90% $U_R$ (2)	-	V
			Insulation Resistance	Table 2, Item 3	Ri	(4)	-	MΩ
			Capacitance	Table 2, Item 9	C	Table 2	-	pF
			Capacitance Change	Table 2, Item 9	$\Delta C/C$	-	Table 4	%
14	Corrosion	Para. 9.20	<u>Final Measurements</u> Visual Examination	No corrosion, damage or obliteration of marking	-	-	-	-
15	Permanence of Marking	Para. 9.21	<u>Final Measurements</u> Visual Examination	No corrosion or obliteration of marking	-	-	-	-
16	Damp Heat (Non-hermetically Sealed)	Para. 9.24	<u>Final Measurements</u> Visual Examination Insulation Resistance	After 4 hours recovery No cracking or encapsulant separation Under 1.5V	- - Ri	- - (5)	- - -	- - MΩ

**NOTES:**

1. The tests in this Table refer to either Chart IV or V and shall be used as applicable.
2. For  $U_R$ , see Table 1(b).
3. For  $I_R$ , see Table 1(b).
4. Greater than 50% of the value given in Table 2.
5. Greater than 10% of the value given in Table 2.
6. For Voltage Drop limit, see Table 1(b).
7. The minimum current required for monitoring purposes shall be applied (see Para. 9.11.3 of ESCC Generic Specification No. 3008).