



Pages 1 to 15

CONTACTS, ELECTRICAL, CRIMP FOR 3401/073 SOLAR ARRAY CONNECTORS

ESCC Detail Specification No. 3401/074

Issue 2	May 2009
---------	----------



Document Custodian: European Space Agency - see <https://escies.org>

LEGAL DISCLAIMER AND COPYRIGHT

European Space Agency, Copyright © 2009. All rights reserved.

The European Space Agency disclaims any liability or responsibility, to any person or entity, with respect to any loss or damage caused, or alleged to be caused, directly or indirectly by the use and application of this ESCC publication.

This publication, without the prior permission of the European Space Agency and provided that it is not used for a commercial purpose, may be:

- copied in whole, in any medium, without alteration or modification.
- copied in part, in any medium, provided that the ESCC document identification, comprising the ESCC symbol, document number and document issue, is removed.

DOCUMENTATION CHANGE NOTICE

(Refer to <https://escies.org> for ESCC DCR content)

DCR No.	CHANGE DESCRIPTION
457	Specification updated to incorporate editorial and technical changes per DCR.

TABLE OF CONTENTS

1.	<u>GENERAL</u>	<u>6</u>
1.1	Scope	6
1.2	Type Variants	6
1.3	Maximum Ratings	6
1.4	Parameter Derating Information	6
1.5	Physical Dimensions	6
2.	<u>APPLICABLE DOCUMENTS</u>	<u>9</u>
3.	<u>TERMS, DEFINITIONS, ABBREVIATIONS, SYMBOLS AND UNITS</u>	<u>9</u>
4.	<u>REQUIREMENTS</u>	<u>9</u>
4.1	General	9
4.2	Deviations from Generic Specification	9
4.2.1	Deviations from Special In-process Controls	9
4.2.2	Deviations from Final Production Tests (Chart II)	9
4.2.3	Deviations from Burn-in and Electrical Measurements (Chart III)	9
4.2.4	Deviations from Qualification Tests (Chart IV)	9
4.2.5	Deviations from Lot Acceptance Tests (Chart V)	9
4.3	Mechanical Requirements	10
4.3.1	Dimension Check	10
4.3.2	Weight	10
4.3.3	Contact Capability	10
4.3.4	Contact Retention (in insert)	10
4.3.5	Mating and Unmating Forces	10
4.3.6	Insert Retention (in shell)	10
4.3.7	Jackscrew Retention	10
4.3.8	Contact Insertion and Withdrawal Forces	10
4.3.9	Engagement and Separation Forces	10
4.3.10	Oversize Pin Exclusion	10
4.3.11	Probe Damage	10
4.3.12	Solderability	10
4.4	Materials and Finishes	10
4.4.1	Shells	11
4.4.2	Inserts	11
4.4.3	Contacts	11
4.4.4	Contact Retaining Clip	11
4.4.5	Guiding and Locking Devices	11
4.4.6	Magnetism Level	11
4.5	Marking	11
4.5.1	General	11
4.5.2	Contact Identification	11
4.5.3	The ESCC Component Number	11
4.5.4	Traceability Information	11
4.6	Electrical Measurements	12
4.6.1	Electrical Measurements at Room Temperature	12
4.6.2	Electrical Measurements at High and Low Temperatures	12
4.6.3	Circuits for Electrical Measurements	12
4.7	Burn-in And Electrical Measurements	12
4.8	Environmental and Endurance Tests	12
4.8.1	Measurements and Inspections on Completion of Environmental Tests	12
4.8.2	Measurements and Inspections at Intermediate Points During Endurance Tests	12
4.8.3	Measurements and Inspections on Completion of Endurance Tests	12



4.8.4	Conditions for Operating Life (Part of Endurance Testing)	12
4.8.5	Electrical Circuit for Operating Life	12
4.8.6	Conditions for High Temperature Storage Test (Part of Endurance Testing)	12
APPENDIX 'A'		15

1. GENERAL

1.1 SCOPE

This specification details the ratings, physical and electrical characteristics, test and inspection data for Contacts, Electrical, Crimp for 3401/073 Solar Array Connectors.

These contacts shall be packed separately from the connectors and may be procured either with the connectors or separately.

The specification shall be read in conjunction with:

- ESCC Generic Specification No. 3401, Connectors, Electrical, Non-Filtered, Circular and Rectangular.
- ESCC Detail Specification No. 3401/073, Connectors, Electrical, Solar Array with Removable Crimp Contacts Based on Type D-PASO.

the requirements of which are supplemented herein.

1.2 TYPE VARIANTS

The different sizes of contacts specified herein, which are also covered by this specification are scheduled in Table 1(a).

1.3 MAXIMUM RATINGS

The maximum ratings, which shall not be exceeded at any time during use or storage, applicable to the contacts specified herein, are as scheduled in Table 1(b).

1.4 PARAMETER DERATING INFORMATION

Not applicable.

1.5 PHYSICAL DIMENSIONS

The physical dimensions of the contacts specified herein are shown in Figure 2.

TABLE 1(a) - TYPE VARIANTS

Characteristics			Variant		Unit
			01	02	
Type			Male	Female	-
Mating End Size			20	20	AWG
Crimp Barrel Size			18	18	AWG
Rated Current			7.5	7.5	A
Accept Wire			18, 20, 22, 24	18, 20, 22, 24	AWG
Maximum Weight			0.14	0.17	g
Engagement and Separation - Contact Engagement Force	Maximum Force		-	3.3	N
	Test Pin Diameter	Minimum	-	1.038	mm
		Maximum	-	1.041	mm

Characteristics			Variant		Unit
			01	02	
Engagement and Separation - Contact Separation Force	Minimum Force		-	0.28	N
	Test Pin Diameter	Minimum	-	0.991	mm
		Maximum	-	0.994	mm
Contact Capability-Pick-Up Weight	Weight		-	20.39	g
	Test Pin Diameter	Minimum	-	0.991	mm
		Maximum	-	0.994	mm
	Minimum Insertion Depth		-	4	mm
Contact Capability-Drop Weight	Weight		-	519.9	g
	Test Pin Diameter	Minimum	-	1.038	mm
		Maximum	-	1.041	mm
	Minimum Insertion Depth		-	4	mm
Contact Retention Force (in insert)			40	40	N
Contact Insertion and Withdrawal Force		Maximum	0.25	0.25	N
Probe Damage	Moment		-	5.7	Ncm
	Probe Diameter	Minimum	-	1.01	mm
		Maximum	-	1.03	mm
Oversize Pin Exclusion	Force		-	5.5	N
	Pin Diameter	Minimum	-	1.165	mm
		Maximum	-	1.175	mm

TABLE 1(b) - MAXIMUM RATINGS

No.	Characteristics	Symbol	Maximum Rating	Unit
1	Rated Current	I_{CR}	7.5	A
2	Operating Temperature Range	T_{op}	-175 to +130	°C
3	Storage Temperature Range	T_{stg}	-196 to +170	°C

FIGURE 1- PARAMETER DERATING INFORMATION

Not applicable.

FIGURE 2 - PHYSICAL DIMENSIONS
Variant 01 - Male Contact

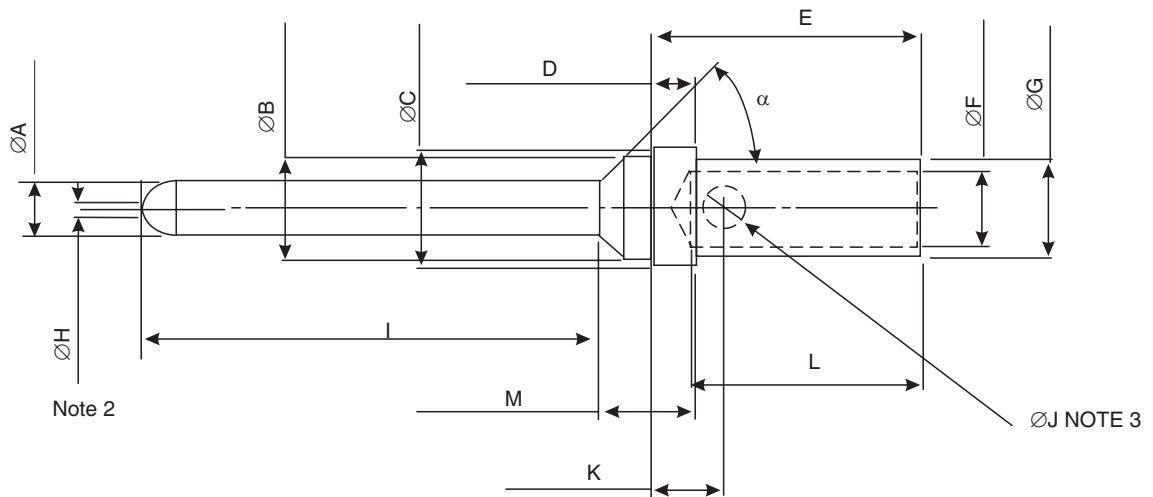

	α	$\varnothing A$	$\varnothing B$	$\varnothing C$	D	E	$\varnothing F$	$\varnothing G$	$\varnothing H$	I	$\varnothing J$	K	L	M
Min	TYP 45°	0.99	1.78	2.08	0.74	4.8	1.30	1.73	-	8.2	0.6	1.24	3.6	1.65
Max		1.04	1.85	2.16	0.84	4.93	1.35	1.8	0.3	8.25	0.85	1.4	4.7	1.75

NOTES:

1. All dimensions are in millimetres.
2. Maximum Flat End dimension.
3. Inspection hole $\varnothing J$ shall only penetrate one wall of the crimp barrel.

Variant 02 - Female Contact

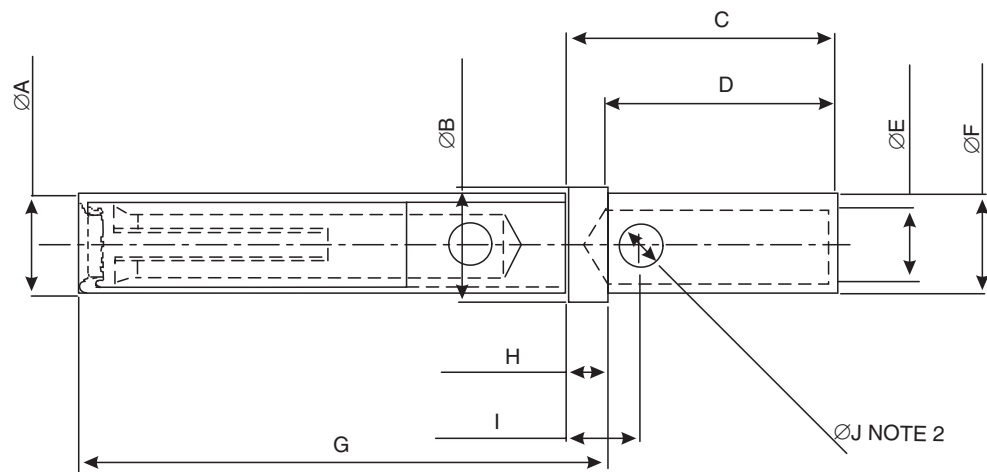

	$\varnothing A$	$\varnothing B$	C	D	$\varnothing E$	$\varnothing F$	G	H	I	$\varnothing J$
Min	-	2.08	4.8	3.6	1.3	1.73	9.45	0.74	1.24	0.6
Max	1.85	2.16	4.9	4.7	1.35	1.80	9.65	0.84	1.40	0.85

NOTES:

1. All dimensions are in millimetres.
2. Inspection hole ØJ shall only penetrate one wall of the crimp barrel.

2. APPLICABLE DOCUMENTS

The following documents form part of this specification and shall be read in conjunction with it:

- (a) ESCC Generic Specification No. 3401 for Connectors, electrical, Non-Filtered, Circular and Rectangular.
- (b) ESCC Detail specification No. 3401/073, Connectors, Electrical, Solar Array with Removable Crimp Contacts Based on type D-PASO.

3. TERMS, DEFINITIONS, ABBREVIATIONS, SYMBOLS AND UNITS

For the purpose of this specification, the terms, definitions, abbreviations, symbols and units specified in ESCC Basic Specification No. 21300 shall apply.

4. REQUIREMENTS**4.1 GENERAL**

The complete requirements for procurement of the contacts specified herein are stated in this specification and ESCC Generic Specification No. 3401. Deviations from the Generic Specification, applicable to this specification only, are detailed in Para. 4.2.

Deviations from the Generic Specification and this Detail Specification, formally agreed with specific Manufacturers on the basis that the alternative requirements are equivalent to the ESCC requirements and do not affect the components' reliability, are listed in the appendices attached to this specification.

4.2 DEVIATIONS FROM GENERIC SPECIFICATION**4.2.1 Deviations from Special In-process Controls**

None.

4.2.2 Deviations from Final Production Tests (Chart II)

None.

4.2.3 Deviations from Burn-in and Electrical Measurements (Chart III)

Not applicable.

4.2.4 Deviations from Qualification Tests (Chart IV)

- (a) Para. 9.31, Solderability: Not applicable.

4.2.5 Deviations from Lot Acceptance Tests (Chart V)

None.

4.3 MECHANICAL REQUIREMENTS

4.3.1 Dimension Check

The dimensions of the contacts specified herein shall be verified in accordance with the requirements set out in Para. 9.6 of ESCC Generic Specification No. 3401 and they shall conform to those shown in Figure 2 of this specification.

4.3.2 Weight

The maximum weight of the contacts specified herein shall be as specified in Table 1(a).

4.3.3 Contact Capability

For the purpose of this test, the pick-up and drop weights shall be as specified in Table 1(a).

4.3.4 Contact Retention (in insert)

The contact retention force shall be as specified in Table 1(a).

4.3.5 Mating and Unmating Forces

As specified in ESCC Detail Specification No. 3401/073.

4.3.6 Insert Retention (in shell)

As specified in ESCC Detail Specification No. 3401/073.

4.3.7 Jackscrew Retention

Not applicable.

4.3.8 Contact Insertion and Withdrawal Forces

The contact insertion and withdrawal forces shall be as specified in Table 1(a).

4.3.9 Engagement and Separation Forces

The diameter of the test pin and the engagement and separation forces of the female contacts shall be as specified in Table 1(a)

4.3.10 Oversize Pin Exclusion

The diameter of the test pin and the force applied to it shall be as specified in Table 1(a).

4.3.11 Probe Damage

The probe diameter and the moment at the end of the probe shall be as specified in Table 1(a)

4.3.12 Solderability

Not applicable.

4.4 MATERIALS AND FINISHES

The materials and finishes shall be as specified herein. Where a definite material is not specified, a material which will enable the contacts specified herein to meet the performance requirements of this specification shall be used. Acceptance or approval of any constituent material does not guarantee acceptance of the finished product.

4.4.1 Shells

As specified in ESCC Detail Specification No. 3401/073.

4.4.2 Inserts

As specified in ESCC Detail Specification No. 3401/073.

4.4.3 Contacts

The contact body shall be made of copper alloy with an underplate of 1 μ m minimum of nickel gold plated with 1.27 μ m of gold.

The female contact spring element shall be made of copper alloy with an underplate of 1 μ m minimum of nickel, gold plated with 1.27 μ m minimum of gold.

4.4.4 Contact Retaining Clip

As specified in ESCC Detail Specification No. 3401/073.

4.4.5 Guiding and Locking Devices

As specified in ESCC Detail Specification No. 3401/073.

4.4.6 Magnetism Level

As specified in ESCC Detail Specification No. 3401/073.

4.5 MARKING

4.5.1 General

The marking of all components delivered to this specification shall be in accordance with the requirements of ESCC Basic Specification No. 21700 and the following subparagraphs. When the component is too small to accommodate all of the marking specified, as much as space permits shall be marked and the marking information, in full, shall accompany the component in its primary package.

The information to be marked and the order of precedence, shall be as follows:

- (a) Contact Identification.
- (b) The ESCC Component Number.
- (c) Traceability Information

4.5.2 Contact Identification

Not applicable.

4.5.3 The ESCC Component Number

The ESCC Component Number shall be constituted and marked as follows:

340107401B

- Detail Specification Reference: 3401074
- Type Variant (See Table 1(a)): 01
- Testing Level: B

4.5.4 Traceability Information

Each component shall be marked in respect of traceability information in accordance with the requirements of ESCC Basic Specification No. 21700.

4.6 ELECTRICAL MEASUREMENTS

4.6.1 Electrical Measurements at Room Temperature

The parameters to be measured at room temperature are scheduled in Table 2. Unless otherwise specified, measurements shall be performed at $T_{amb}=+22\pm 3^{\circ}C$.

4.6.2 Electrical Measurements at High and Low Temperatures

Not applicable.

4.6.3 Circuits for Electrical Measurements

Not applicable.

4.7 BURN-IN AND ELECTRICAL MEASUREMENTS

Not applicable.

4.8 ENVIRONMENTAL AND ENDURANCE TESTS

4.8.1 Measurements and Inspections on Completion of Environmental Tests

The parameters to be measured and inspections to be performed on completion of environmental tests are scheduled in Table 6. Unless otherwise stated, the measurements shall be performed at $T_{amb}=+22\pm 3^{\circ}C$.

4.8.2 Measurements and Inspections at Intermediate Points During Endurance Tests

Not applicable.

4.8.3 Measurements and Inspections on Completion of Endurance Tests

The parameters to be measured and inspections to be performed on completion of endurance tests are scheduled in Table 6. Unless otherwise stated, the measurements shall be performed at $T_{amb}=+22\pm 3^{\circ}C$.

4.8.4 Conditions for Operating Life (Part of Endurance Testing)

Not applicable.

4.8.5 Electrical Circuit for Operating Life

Not applicable.

4.8.6 Conditions for High Temperature Storage Test (Part of Endurance Testing)

The requirements for the high temperature storage test are specified in Section 9 of ESCC Generic specification No. 3401. The conditions for high temperature storage testing shall be the maximum storage temperature specified in Table 1(b) of this specification.

TABLE 2 - ELECTRICAL MEASUREMENTS AT ROOM TEMPERATURE

No.	Characteristics	Symbol	ESCC 3401 Test Method	Test Conditions	Variants	Limits		Unit
						Min	Max	
1	Low Level Contact Resistance	R_{cl}	Para 9.1.1.3	Para. 9.1.1.3	All	-	8	m Ω

No.	Characteristics	Symbol	ESCC 3401 Test Method	Test Conditions	Variants	Limits		Unit
						Min	Max	
2	Rated Current Contact Resistance	R_{cr}	Para 9.1.1.3	Para. 9.1.1.3 7.5A	All	-	14	mΩ

TABLES 3, 4 AND 5

Not applicable.

TABLE 6 - MEASUREMENTS AND INSPECTIONS ON COMPLETION OF ENVIRONMENTAL AND ENDURANCE TESTING

No.	ESCC Generic Spec. No. 3401		Measurements and Inspections		Symbol	Limits		Unit
	Environmental and Endurance Tests (1)	Test Methods and Conditions	Identification	Conditions		Min	Max	
01	Wiring	Para. 9.10 & Table 1(a) of this spec.	Visual Inspection Low Level Contact Resistance	- Table 2 Item 1	- R_{cl}	- Table 2 Item 1	-	
02	Vibration	Para. 9.11	ESCC 3401/073	-	-	-	-	
03	Bump	Para. 9.12.2	ESCC 3401/073	-	-	-	-	
04	Climatic Sequence	Para. 9.13	ESCC 3401/073	-	-	-	-	
05	Seal Test	Para. 9.9	-	-	-	Not applicable		
06	Plating Thickness	Para. 9.14	Thickness	-	-	Para. 4.4.3 of this spec.		
07	Joint Strength	Para. 9.15	ESCC 3401 Para. 9.15	-	-	-	-	
08	Rapid Change of Temperature	Para. 9.16	ESCC 3401/073	-	-	-	-	
09	Rapid Change of Temperature with Vacuum Applied	Para. 9.16	ESCC 3401/073	-	-	-	-	
10	Extended Rapid Change of Temperature without Vacuum Applied	Para. 9.16	ESCC 3401/073	-	-	-	-	
11	Contact Retention (in insert)	Para. 9.17 & Para. 4.3.4 of this spec.	Contact Displacement	-	-	ESCC 3401 Para. 9.17		
12	Endurance	Para. 9.18	Initial Measurements Low Level Contact Resistance	Table 2 Item 1	R_{cl}	Record Values		
			Final Measurements Low Level Contact Resistance Drift	Table 2 Item 1	ΔR_{cl}	-	± 3	mΩ
13	Permanence of Marking	Para. 9.19	Not applicable	-	-	-	-	-
14	Mating/Unmating Forces	Para. 9.20	ESCC 3401/073	-	-	-	-	-
15	High Temperature Storage	Para. 9.21	Initial Measurements Low Level Contact Resistance	Table 2 Item 1	R_{cl}	Record Values		

No.	ESCC Generic Spec. No. 3401		Measurements and Inspections		Symbol	Limits		Unit
	Environmental and Endurance Tests (1)	Test Methods and Conditions	Identification	Conditions		Min	Max	
			Final Measurements					
			Low Level Contact Resistance Drift	Table 2 Item 1	ΔR_{cl}	-	± 3	m Ω
			Rated Current Contact Resistance	Table 2 Item 2	R_{cr}	Table 2 Item 2		
			Contact Retention (in insert)	Para. 4.3.4 of this spec.	-	ESCC 3401 Para. 9.17		
16	Corrosion	Para. 9.22	Visual Examination	-	-	-	-	
17	Insert Retention (in shell)	Para. 9.23 & Para. 4.3.6 of this spec.	ESCC 3401/073	-	-	-	-	
18	Jackscrew Retention	Para. 9.24 & Para. 4.3.7 of this spec.	-	-	-	Not applicable		
19	High Temperature Measurements	Para. 9.25	ESCC 3401/073	-	-	-	-	
20	Overload Test	Para. 9.26	Rated Current Contact Resistance	Table 2 item 2	R_{cr}	Table 2 Item 2		
21	Maintenance Aging	Para. 9.27	Contact Insertion Force	Para. 4.3.8 of this spec.	-	Para. 4.3.8 of this spec.		
			Contact Retention (in insert)	Para. 4.3.4 of this spec.	-	ESCC 3401 Para. 9.17		
			Contact Insertion & Withdrawal Forces	Para. 4.3.8 of this spec.	-	Para. 4.3.8 of this spec		
22	Engagement and Separation Forces	Para. 9.28 & para. 4.3.9 of this spec.	Forces	-	-	Para. 4.3.9 of this spec.		
23	Oversize Pin Exclusion	Para. 9.29 & para. 4.3.10 of this spec.	-	-	-	ESCC 3401 Para. 9.29		
24	Probe Damage	Para. 9.30 & para. 4.3.11 of this spec.	Contact Separation Force	Para. 4.3.9 of this spec.	-	Para. 4.3.9 of this spec.		
25	Solderability	Para. 9.31 & para. 4.3.12 of this spec.	Not applicable	-	-	-	-	

NOTES:

1. The tests in this Table refer to either Chart IV or V and shall be used as applicable.

APPENDIX 'A'**AGREED DEVIATIONS FOR COMPAGNIE DEUTSCH (F)**

ITEMS AFFECTED	DESCRIPTION OF DEVIATIONS
Figure 2	The contacts may be marked in accordance with ISO 8843. If marked the Permanence of Marking per Para. 9.19 of ESCC No. 3401 shall apply.
Para. 4.2.2	Para. 9.5 Magnetism Level: May be guaranteed but not tested.