



Pages 1 to 18

CONNECTORS, ELECTRICAL, Z-AXIS INTERPOSER BASED ON TYPE RX

ESCC Detail Specification No. 3401/076

Issue 1	April 2007
---------	------------



Document Custodian: European Space Agency - see <https://escies.org>

LEGAL DISCLAIMER AND COPYRIGHT

European Space Agency, Copyright © 2007. All rights reserved.

The European Space Agency disclaims any liability or responsibility, to any person or entity, with respect to any loss or damage caused, or alleged to be caused, directly or indirectly by the use and application of this ESCC publication.

This publication, without the prior permission of the European Space Agency and provided that it is not used for a commercial purpose, may be:

- copied in whole, in any medium, without alteration or modification.
- copied in part, in any medium, provided that the ESCC document identification, comprising the ESCC symbol, document number and document issue, is removed.

DOCUMENTATION CHANGE NOTICE

(Refer to <https://escies.org> for ESCC DCR content)

DCR No.	CHANGE DESCRIPTION

TABLE OF CONTENTS

<u>1.</u>	<u>GENERAL</u>	<u>5</u>
1.1	Scope	5
1.2	Range of Components	5
1.2.1	Manufacturer Specific Connector Design Drawing	5
1.3	Maximum Ratings	5
1.4	Parameter Derating Information	5
1.5	Physical Dimensions	5
<u>2.</u>	<u>APPLICABLE DOCUMENTS</u>	<u>5</u>
<u>3.</u>	<u>TERMS, DEFINITIONS, ABBREVIATIONS, SYMBOLS AND UNITS</u>	<u>6</u>
<u>4.</u>	<u>REQUIREMENTS</u>	<u>11</u>
4.1	General	11
4.2	Deviations from Generic Specification	11
4.2.1	Deviations from Special In-process Controls	11
4.2.2	Deviations from Final Production Tests (Chart II(b))	12
4.2.3	Deviations from Burn-in and Electrical Measurements (Chart III)	12
4.2.4	Deviations from Qualification Tests (Chart IV)	12
4.2.5	Deviations from Lot Acceptance Tests (Chart V)	13
4.3	Mechanical Requirements	13
4.3.1	Dimension Check	13
4.3.2	Weight	13
4.4	Materials and Finishes	13
4.4.1	Connector Body/Insulator	13
4.4.2	Contacts	14
4.4.3	Locking and Guiding Devices	14
4.4.4	Magnetism Level	14
4.5	Marking	14
4.5.1	General	14
4.5.2	The ESCC Component Number	14
4.5.3	Traceability Information	14
4.6	Electrical Measurements	14
4.6.1	Electrical Measurements at Room Temperature	14
4.6.2	Electrical Measurements at High and Low Temperatures	15
4.6.3	Circuit for Electrical Measurements	15
4.7	Burn-in and Electrical Measurements	15
4.8	Environmental and Endurance Tests (Charts IV and V of ESCC Generic Specification No. 3401)	15
4.8.1	Measurements and Inspections on Completion of Environmental Tests	15
4.8.2	Measurements and Inspections at Intermediate Points During Endurance Tests	15
4.8.3	Measurements and Inspections on Completion of Endurance Tests	15
4.8.4	Conditions for Operating Life Test (Part of Endurance Testing)	15
4.8.5	Electrical Circuit for Operating Life Test	15
4.8.6	Conditions for High Temperature Storage Test (Part of Endurance Testing)	15

1. **GENERAL**

1.1 **SCOPE**

This specification details the ratings, physical and electrical characteristics, test and inspection data for Connectors, Electrical, Z-Axis Interposer based on type RX. It shall be read in conjunction with:

- ESCC Generic Specification No. 3401, Connectors, Electrical, Non-Filtered, Circular and Rectangular.

the requirements of which are supplemented herein.

1.2 **RANGE OF COMPONENTS**

The possible different configurations of the connectors and contacts with locking and guiding devices are given in Table 1(a).

1.2.1 **Manufacturer Specific Connector Design Drawing**

A Specific Connector Design Drawing shall be produced by the Manufacturer after negotiation with the Orderer and shall be held under configuration control by the Manufacturer who will allocate a unique drawing number which shall be used to identify the connector.

Each Manufacturer Specific Connector Design Drawing shall include the following information:-

- (a) The connector outline and dimensions including full details of contacts and all locking and guiding devices plus the configuration of rows and columns.
- (b) The ESCC Component Number for the connector including the variant number, testing level and the unique Manufacturer Specific Connector Design Drawing Number.
- (c) Materials for the Locking and Guiding Devices (as applicable).
- (d) Maximum Weight.

1.3 **MAXIMUM RATINGS**

The maximum ratings, which shall not be exceeded at any time during use or storage, applicable to the connectors specified herein, are scheduled in Table 1(b).

1.4 **PARAMETER DERATING INFORMATION**

The applicable derating information for the connectors specified herein is shown in Figure 1.

1.5 **PHYSICAL DIMENSIONS**

Common physical dimensions of the connectors, the contact mounting configurations and the locking and guiding devices are shown in Figure 2.

2. **APPLICABLE DOCUMENTS**

The following documents form part of this specification and shall be read in conjunction with it:

ESCC Generic Specification No. 3401, Connectors, Electrical, Non-Filtered, Circular and Rectangular.

3. TERMS, DEFINITIONS, ABBREVIATIONS, SYMBOLS AND UNITS

For the purpose of this specification, the terms, definitions, abbreviations, symbols and units specified in ESCC Basic Specification No. 21300 shall apply.

TABLE 1(a) - RANGE OF COMPONENTS (NOTE 1)
Connector Bodies

Connector Body					Devices	
Maximum Number of Rows	Maximum B Dimension (mm)	Maximum Width F (mm)	Maximum Length E (mm)	Maximum number of Contacts	Type of Locking or Guiding Devices	Number of Locking or Guiding Devices
4	131.2	9.5	138	266	See Devices Table	2
5	98.4	11	105	248		2
7	65.6	14	73	228		2
7	65.6	14	138	456		3
9	49.2	17	56	220		2
9	49.2	17	105	440		3
9	49.2	17	152	660		4
11	39.4	20	49	204		2
11	39.4	20	86	408		3
11	39.4	20	125	612		4

Locking and Guiding Devices

Device Style	Maximum Substrate Thickness (mm)
Through Holes only	N/A
M2 Studs with Locking nuts and washers	2.85
M2 Studs with Locking nuts and washers	4.4
Locating Pins	N/A

NOTES:

- Each Manufacturer Specific Connector Design Drawing shall fully define and identify a specific connector within the maximum design envelopes specified.

TABLE 1(b) - MAXIMUM RATINGS

No.	Characteristics	Symbol	Maximum Ratings	Unit	Remarks
1	Working Voltage	V_R	160	V_{rms}	Between Contacts, Sea Level See Figure 1

No.	Characteristics	Symbol	Maximum Ratings	Unit	Remarks
2	Rated Current	I_R	1	A	Each Contact
3	Operating Temperature Range	T_{op}	-55 to +125	°C	T_{amb}
4	Storage Temperature Range	T_{stg}	-55 to +125	°C	
5	Total Contact Compression Range to ensure performance	d	0.1 to 0.65	mm	Per contact, each end
6	Compression Force	F	1.6	N	Per Contact Totally compressed, 2xA of Figure 2(b)
7	Torque for Locking Devices	τ	10	Ncm	Applies to all locking devices

FIGURE 1 - PARAMETER DERATING INFORMATION
Working Voltage Versus Altitude

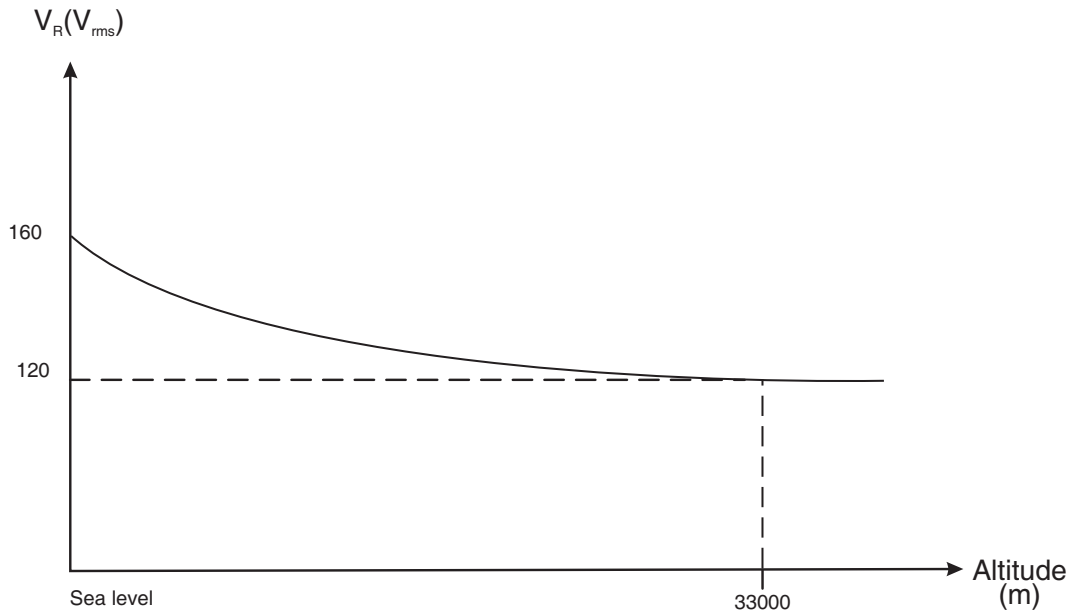
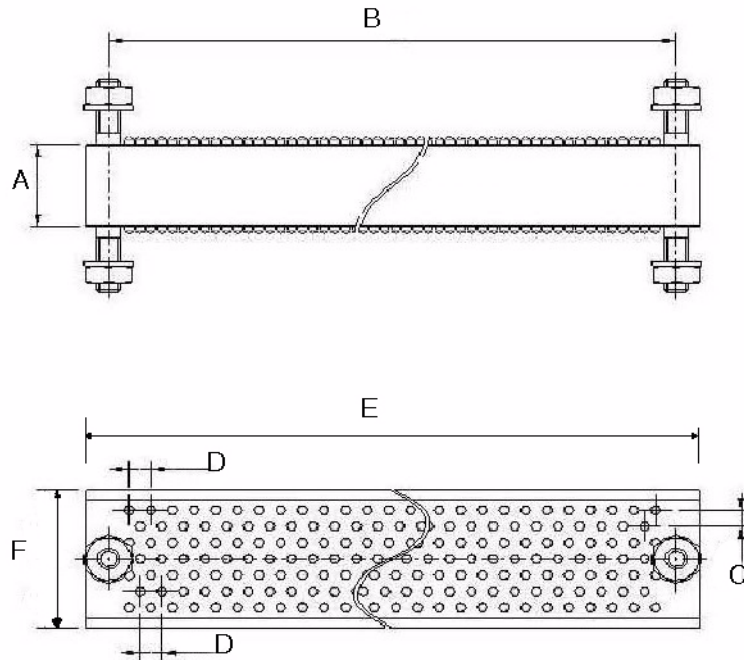

Figure 2 - PHYSICAL DIMENSIONS

Figure 2(a) General Dimensions



Symbol	Dimensions mm		Notes
	Min	Max	
A	7.7	7.8	1
B	-	See Table 1(a)	2, 3
C	1.324	1.724	4
D	1.705	2.105	4
E	-	See Table 1(a)	3
F	-	See Table 1(a)	3

NOTES:

1. Dimension A shall be measured at each end and at the middle of the connector.
2. Dimension B is the centre spacing for the locking and guiding through-holes or devices.
3. The tolerance shall be $\pm 0.5\text{mm}$.
4. All contacts.
5. A suitable clearance shall be applied between the contacts and the locking or guiding through-holes or devices.

Figure 2(b) - Exposed Contact Dimensions (Per Side)

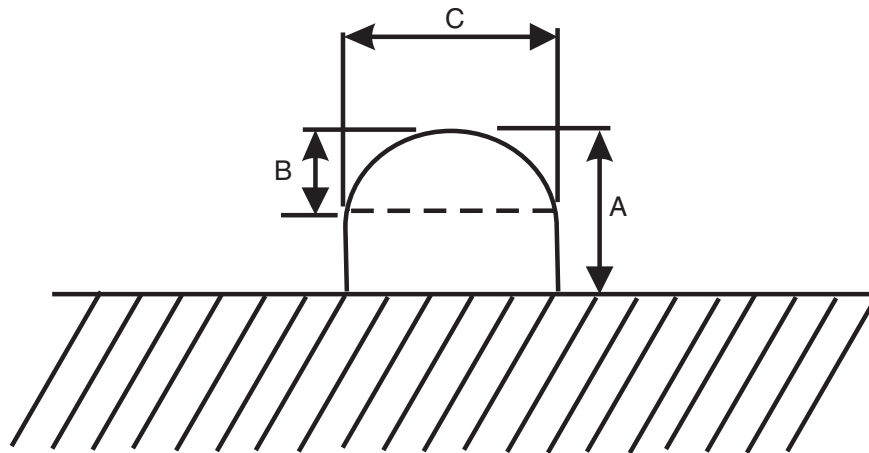

Connector Body

Symbol	Dimensions mm		Notes
	Min	Max	
A	0.4	0.65	1
B	0.45	0.55	2
C	0.9	1.1	3, 4

NOTES:

1. Dimension with contact uncompressed.
2. Radius
3. Diameter
4. The contacts are designed to be used with 0.8mm diameter substrate pads.

Figure 2(c) Locking Devices

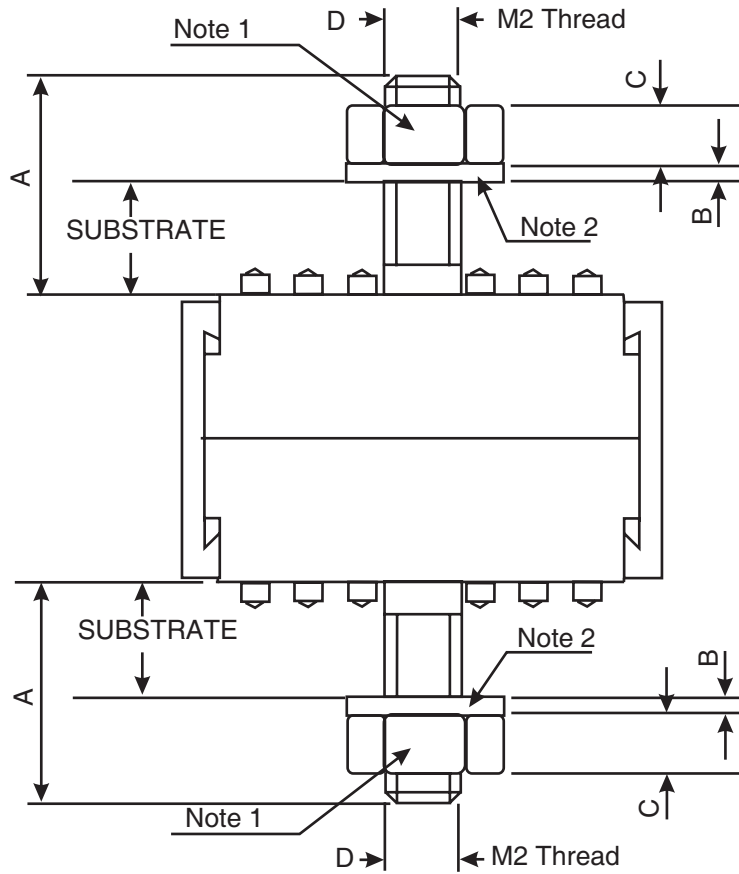

Symbol	Dimensions mm		Notes
	Min	Max	
A	4.8	5.5	3
	6.35	7.05	4
B	0.25	0.35	
C	1.35	1.6	
D	M2		1, 2

NOTES:

1. Hexagonal M2 Nut, 3.2mm (nominal) across the flats. The maximum locking torque shall be as specified in Table 1(b).
2. M2 Flat Washer 4mm (nominal) outside diameter.
3. Locking device for maximum substrate thickness of 2.85mm
4. Locking device for maximum substrate thickness of 4.4mm.

Figure 2(d) Guiding Device

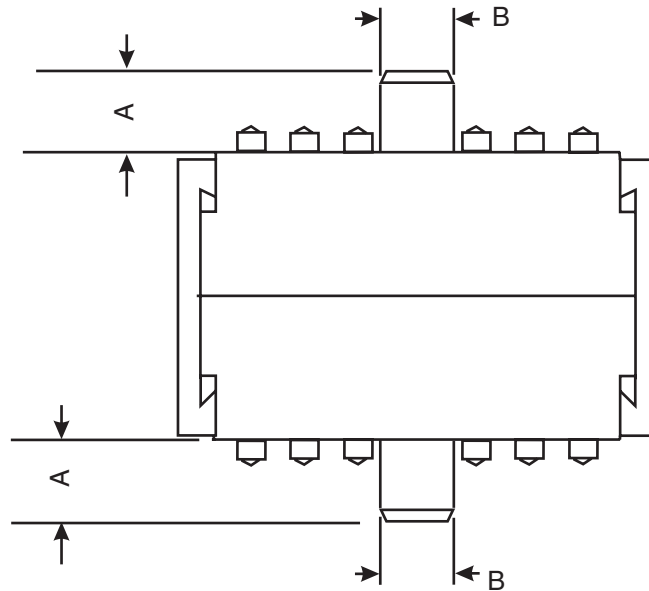

Symbol	Dimensions mm		Notes
	Min	Max	
A	1.3	1.5	
B	1.9	2	1

NOTES:

1. Diameter

4. REQUIREMENTS

4.1 GENERAL

The complete requirements for procurement of the components specified herein are stated in this specification and ESCC Generic Specification No. 3401. Deviations from the Generic Specification, applicable to this specification only, are detailed in Para. 4.2.

Deviations from the Generic Specification and this Detail Specification, formally agreed with specific Manufacturers on the basis that the alternative requirements are equivalent to the ESCC requirements and do not affect the components' reliability, are listed in the appendices attached to this specification.

4.2 DEVIATIONS FROM GENERIC SPECIFICATION

4.2.1 Deviations from Special In-process Controls

- (a) Para. 5.2.4, Crimping Capability: Not applicable.
- (b) Para. 5.2.3, Plating Thickness: Shall be performed on 20 samples.
- (c) Para. 5.2.5, Solderability: Not applicable.

4.2.2 Deviations from Final Production Tests (Chart II(b))

- (a) Para. 9.4, Contact Capability: Not applicable.
- (b) Para. 9.6, Dimensional Check (Contacts): Not applicable.
- (c) Immediately after Para. 9.8, Installation of Contacts into Inserts, and prior to Para. 9.1.4, Electrical Measurements at Room Temperature, 10 compression/decompression cycles shall be performed.
- (d) Para. 9.1.4, Electrical Measurements at Room Temperature: The Rated Current Contact Resistance Test shall be omitted and the Low Level Contact Resistance shall be performed with the sampling per Para 9.6 applied.
- (e) Para. 9.2, Mating Verification: Not applicable.
- (f) Para. 9.5, Magnetism Level: Not applicable.

4.2.3 Deviations from Burn-in and Electrical Measurements (Chart III)

Not applicable.

4.2.4 Deviations from Qualification Tests (Chart IV)

- (a) Only Subgroups I through III shall be performed on 12 connectors, 4 per subgroup. Subgroups IV and VI shall not be performed. Subgroup V, Para 9.14 Plating Thickness only, shall be performed on 35 contacts.
- (b) Para. 9.10, Wiring: Not applicable.
- (c) Para. 9.11.1, Vibration (General): Contacts shall be compressed between two printed circuit boards which shall have suitable contact pads and circuitry to allow monitoring of contacts per Para. 9.11.1(b). The normal mounting means shall be used, utilising the locking and guiding devices where applicable.
The connector/printed circuit board sandwich shall be rigidly installed into the vibration fixture. All vibration tests shall be performed with the contacts depressed to 0.3mm minimum per side between the fixture plates and the connector body.
Screw Unlocking Torque: Shall be performed on Locking Devices with a locking torque of 10Ncm.
- (d) Para. 9.11.3, Random Vibration Testing:
The connectors shall be submitted to random vibration testing with $f_1 = 50\text{Hz}$, $f_2 = 2000\text{Hz}$, an Acceleration Spectral Density of $0.4g^2/\text{Hz}$, a total test period of 10 minutes with high reproducibility. This cycle shall be performed once in each of the 3 mutually perpendicular directions so that the motion is applied for a total period of approximately 30 minutes. All other requirements per Para. 9.11.3 shall apply.
- (e) Para. 9.12, Shock or Bump: The same mounting and monitoring as Para. 9.11.1 shall be used.
- (f) Para. 9.9, Seal Test: Not applicable.
- (g) Para. 9.15, Joint Strength: Not applicable.
- (h) Para. 9.17, Contact Retention: Not applicable.
- (i) Para. 9.18(b), Endurance: The connectors shall be subjected to the following endurance test:
The DUT shall be placed on a horizontal plate using the locking or guiding devices as appropriate; a horizontal plate, parallel to the base plate and covering all the contacts, shall be moved down to completely compress the contacts, and up to release the contacts. The top plate displacement shall be 5mm/s maximum and the cycling rate shall be 8 cycles/minute maximum. This cycle shall be repeated 500 times. All other requirements per Para. 9.18 shall apply.
- (j) Para. 9.20, Mating/Unmating Forces: Not applicable.
- (k) Para. 9.21, High Temperature Storage: Individual contact compression forces shall be measured before and after high temperature on 20% of the contacts evenly distributed over the area of the connector. Insulation resistance shall be measured during this test.
- (l) Para. 9.22, Corrosion: Not applicable.
- (m) Para. 9.23, Insert Retention (in shell): Not applicable.
- (n) Para. 9.24, Jackscrew Retention: Not applicable.
- (o) Para. 9.25, High Temperature Measurements: Insulation Resistance shall be measured during Para. 9.21 High Temperature Storage.
- (p) Para. 9.26, Overload Test shall be performed on the Subgroup II samples after completion of this

subgroup.

- (q) Para. 9.27, Maintenance Aging: Not applicable.
- (r) Para. 9.28, Engagement and Separation Forces: Not applicable.
- (s) Para. 9.29, Oversize Pin Exclusion: Not applicable.
- (t) Para. 9.30, Probe Damage Test: Not applicable.
- (u) Para. 9.31, Solderability: Not applicable.

4.2.5 Deviations from Lot Acceptance Tests (Chart V)

- (a) Level 1 shall be performed on 5 connectors only and Level 2 shall be performed on 2 connectors only.
- (b) Para. 9.10, Wiring: Not applicable.
- (c) Para. 9.22, Corrosion: Not applicable.
- (d) Para. 9.9, Seal Test: Not applicable.
- (e) Para. 9.17, Contact Retention: Not applicable.
- (f) Para. 9.18, Endurance Test: Para. 4.2.4(h) of this specification. Number of cycles shall be 50.
- (g) Para. 9.15, Joint Strength: Not applicable.
- (h) Para. 9.28, Engagement and Separation Forces: Not applicable.
- (i) Para. 9.29, Oversize Pin Exclusion: Not applicable.
- (j) Para. 9.30, Probe Damage: Not applicable.

4.3 MECHANICAL REQUIREMENTS

4.3.1 Dimension Check

The dimensions of the connectors specified herein shall be verified in accordance with requirements set out in Para. 9.6 of ESCC Generic Specification No. 3401 and shall conform to those shown in Figure 2 of this specification and the Manufacturer Specific Connector Design Drawing. Unless otherwise specified for procurement, dimensions to be checked are limited to:

- Figure 2(a) - Dimensions A, B, E and F.
- Figure 2(b) - Dimensions A and C.
- Figure 2(c) - Dimensions A and D.
- Figure 2(d) - Dimensions A and B.

4.3.2 Weight

The maximum weight of the connector, including contacts and guiding/locking devices, shall be specified in the individual Manufacturer Specific Connector Design Drawing.

4.4 MATERIALS AND FINISHES

The materials and finishes shall be as specified herein. Where a definite material is not specified, a material which will enable the connectors specified herein to meet the performance requirements of this specification shall be used. Acceptance or approval of any constituent material does not guarantee acceptance of the finished product.

4.4.1 Connector Body/Insulator

The connector body/insulator shall be made of UL94VO thermoplastic.

4.4.2 Contacts

The contact buttons shall be made of brass. The contact plating shall be 0.1 μ m minimum of gold over 1.27 μ m minimum of nickel.

4.4.3 Locking and Guiding Devices

Where specified, locking and guiding devices shall be made of brass with 1.27 μ m minimum of nickel plating, unplated beryllium copper or unplated non-magnetic stainless steel alloy. The actual materials used shall be specified in the Manufacturer Specific Connector Design Drawing.

4.4.4 Magnetism Level

Not applicable.

4.5 MARKING

4.5.1 General

The marking of all components delivered to this specification shall be in accordance with the requirements of ESCC Basic Specification No. 21700 and the following paragraphs.

The information to be marked and the order of precedence, shall be as follows:

- (a) The ESCC qualified components symbol (for ESCC qualified components only).
- (b) The ESCC Component Number, including the Manufacturer Specific Connector Design Drawing Number.
- (c) Traceability Information.

4.5.2 The ESCC Component Number

The ESCC Component Number shall be constituted and marked as follows:

340107601BXXXX

- Detail Specification Number: 3401076
- Type Variant Number: 01 (see Note 1)
- Testing Level: B
- XXXX: Manufacturer Specific Connector Design Drawing Number.

NOTES:

1. Marking of the Type Variant is mandatory. No further reference to type variants is made in this specification.

4.5.3 Traceability Information

Traceability information shall be marked in accordance with the requirements of ESCC Basic Specification No. 21700.

4.6 ELECTRICAL MEASUREMENTS

4.6.1 Electrical Measurements at Room Temperature

The parameters to be measured at room temperature are scheduled in Table 2. Unless otherwise specified, measurements shall be performed at $T_{amb}=+22\pm 3^{\circ}\text{C}$.

4.6.2 Electrical Measurements at High and Low Temperatures

Not applicable.

4.6.3 Circuit for Electrical Measurements

For electrical measurements both contacts shall be compressed between two printed circuit boards that have gold plated contacts which provide suitable connection to each contact under test. The depression on each contact shall be to 0.3mm minimum per side between the test printed circuit board and the connector body.

4.7 BURN-IN AND ELECTRICAL MEASUREMENTS

Not applicable.

4.8 ENVIRONMENTAL AND ENDURANCE TESTS (CHARTS IV AND V OF ESCC GENERIC SPECIFICATION NO. 3401)

4.8.1 Measurements and Inspections on Completion of Environmental Tests

The parameters to be measured and inspections to be performed on completion of environmental testing are scheduled in Table 6. Unless otherwise specified, the measurements shall be performed at $T_{amb}=+22\pm 3^{\circ}C$.

4.8.2 Measurements and Inspections at Intermediate Points During Endurance Tests

Not applicable.

4.8.3 Measurements and Inspections on Completion of Endurance Tests

The parameters to be measured and inspections to be performed on completion of endurance testing are scheduled in Table 6. Unless otherwise specified, the measurements shall be performed at $T_{amb}=+22\pm 3^{\circ}C$.

4.8.4 Conditions for Operating Life Test (Part of Endurance Testing)

Not applicable.

4.8.5 Electrical Circuit for Operating Life Test

Not applicable.

4.8.6 Conditions for High Temperature Storage Test (Part of Endurance Testing)

The requirements for the high temperature storage test are specified in Section 9 of ESCC Generic Specification No. 3401. The conditions for high temperature storage testing shall be the maximum storage temperature specified in Table 1(b) of this specification.

TABLE 2 - ELECTRICAL MEASUREMENTS AT ROOM TEMPERATURE

No.	Characteristic	Symbol	ESCC 3401 Test Method	Test Condition	Limits		Unit
					Min	Max	
01	Insulation Resistance	R_i	Para. 9.1.1.1	Para. 9.1.1.1	10000	-	M Ω
02	Voltage Proof Leakage Current	I_L	Para. 9.1.1.2	640V _{rms} Sea Level	-	1	mA

No.	Characteristic	Symbol	ESCC 3401 Test Method	Test Condition	Limits		Unit
					Min	Max	
03	Low Level Contact Resistance	R _{cl}	Para. 9.1.1.3(b) and Para. 4.6.3 of this Specification	Para. 9.1.1.3(b) Note 1	-	25	mΩ
04	Rated Current Contact Resistance	R _{cr}	Para. 9.1.1.3(b) and Para. 4.6.3 of this Specification	Para. 9.1.1.3(b) Applied Current =1A Note 2	-	25	mΩ
05	Continuity Test	CON	Condition per Para. 9.11.1(b) and Para. 4.6.3 of this Specification	All contacts tested	-	-	-

NOTES:

1. Sample tested during Final Production Tests.
2. Not performed during Final Production Tests.

Tables 3, 4 and 5 - Not applicable

Table 6 - MEASUREMENTS AND INSPECTIONS ON COMPLETION OF ENVIRONMENTAL AND ENDURANCE TESTING

No.	ESCC Generic Spec. No. 3401		Measurements and Inspections		Symbol	Limits		Unit
	Environmental and Endurance Tests (1)	Test Method and Conditions	Identification	Conditions		Min	Max	
01	Vibration	Para. 9.11 and Para. 4.2.4(c) and (d) of this spec.	Initial Measurements		-	Record Values		-
			Locking Devices Unlocking Torque					
			Final Measurements					
			Locking Devices Unlocking Torque Drift		Δ	-25	+25	%
			Visual Examination	-	-	-	-	-
02	Shock or Bump	Para. 9.12 and Para. 4.2.4(e) of this spec.	Initial Measurements		-	Record Values		-
			Locking Devices Unlocking Torque					
			Final Measurements					
			Locking Devices Unlocking Torque Drift		Δ	-25	+25	%
			Visual Examination	-	-	-	-	-
03	Climatic Sequence	Para. 9.13	Dry Heat					
			Insulation Resistance	Table 2 Item 1 at T _{amb} =+125°C	R _i	500	-	MΩ
			Low Air Pressure					
			Voltage Proof Leakage Current	Figure 1	I _L	ESCC 3401 Para. 9.13.5		mA
			Damp Heat					
			Insulation Resistance	Immediately after test Table 2 Item 1	R _i	100	-	MΩ
			Final Measurements	After 1-24hrs Recovery				

No.	ESCC Generic Spec. No. 3401		Measurements and Inspections		Symbol	Limits		Unit	
	Environmental and Endurance Tests (1)	Test Method and Conditions	Identification	Conditions		Min	Max		
			External Visual Inspection	ESCC 3401 Para. 9.7	-	ESCC 3401 Para. 9.7		-	
			Insulation Resistance	Table 2 Item 1	R_i	Table 2 Item 1		MΩ	
			Voltage Proof Leakage Current	Table 2 Item 2	I_L	Table 2 Item 2		mA	
			Continuity Test	Table 2 Item 5	CON	Table 2 Item 5		-	
04	Plating Thickness	Para. 9.14	Thickness	-	-	Para. 4.4.2 of this spec.		-	
05	Rapid Change of Temperature	Para. 9.16	Final Measurements						
			Visual Examination	-	-	-	-	-	
			Insulation Resistance	Table 2 Item 1	R_i	Table 2 Item 1		MΩ	
			Voltage Proof Leakage Current	Table 2 Item 2	I_L	Table 2 Item 2		mA	
			Continuity Test	Table 2 Item 5	CON	Table 2 Item 5		-	
06	Endurance	Para. 9.18 and Para. 4.2.4(i) of this spec.	Initial Measurements						
			Low Level Contact Resistance all contacts	Table 2 Item 3	R_{cl}	Table 2 Item 3		mΩ	
			Final Measurements						
			Visual Examination	-	-	-	-	-	
			Low Level Contact Resistance Drift all contacts	Table 2 Item 3	ΔR_{cl}	-	±12		mΩ
			Insulation Resistance	Table 2 Item 1	R_i	Table 2 Item 1		MΩ	
			Voltage Proof Leakage Current	Table 2 Item 2	I_L	Table 2 Item 2		mA	
07	Permanence of Marking	Para. 9.19	As applicable	-	-	-	-	-	
08	High Temperature Storage	Para. 9.21 and Para. 4.2.4(k) of this spec.	Initial Measurements						
			Low Level Contact Resistance all contacts	Table 2 Item 3	R_{cl}	Table 2 Item 3		mΩ	
			Final Measurements						
			Visual Examination	-	-	-	-	-	
			Low Level Contact Resistance Drift all contacts	Table 2, Item 3	ΔR_{cl}	-	±12		mΩ
			Rated Current Contact Resistance	Table 2, Item 4	R_{cr}	Table 2 Item 4		mΩ	
			Insulation Resistance	Table 2 Item 1	R_i	Table 2 Item 1		MΩ	
			Voltage Proof Leakage Current	Table 2 Item 2	I_L	Table 2 Item 2		mA	
			Individual Compression Forces	-	F	Table 1(b) Item 6		N	

No.	ESCC Generic Spec. No. 3401		Measurements and Inspections		Symbol	Limits		Unit
	Environmental and Endurance Tests (1)	Test Method and Conditions	Identification	Conditions		Min	Max	
08		Para. 9.25 and Para. 9.2.4(o)	High Temperature Measurements Insulation Resistance at +125°C	- Table 2 Item 1 after a soak at T _{amb} =+125°C for 30 minutes	R _i	500	-	MΩ
09	Overload Test	Para. 9.26	Internal Temperature	-	T	-	+100	°C
			Rated Current Contact Resistance all contacts	Table 2 Item 4	R _{cr}	Table 2 Item 4		mΩ
			Insulation Resistance	Table 2 Item 1	R _i	Table 2 Item 1		MΩ
			Voltage Proof Leakage Current	Table 2 Item 2	I _L	Table 2 Item 1		mA

NOTES:

1. The tests in this table refer to either Chart IV or V and shall be used as applicable.