



Pages 1 to 20

RELAYS, ELECTROMAGNETIC, LATCHING,

50Vdc, 50A, 1PDT

ESCC Detail Specification No. 3602/014

ISSUE 2

September 2004



Document Custodian: European Space Agency - see <https://escies.org>

	ESCC Detail Specification No. 3602/014		PAGE i ISSUE 2
---	---	--	-------------------

LEGAL DISCLAIMER AND COPYRIGHT

European Space Agency, Copyright © 2004. All rights reserved.

The European Space Agency disclaims any liability or responsibility, to any person or entity, with respect to any loss or damage caused, or alleged to be caused, directly or indirectly by the use and application of this ESCC publication.

This publication, without the prior permission of the European Space Agency and provided that it is not used for a commercial purpose, may be:

- copied in whole in any medium without alteration or modification.
- copied in part, in any medium, provided that the ESCC document identification, comprising the ESCC symbol, document number and document issue, is removed.



ESCC Detail Specification
No. 3602/014

PAGE 2

ISSUE 2

DOCUMENTATION CHANGE NOTICE

(Refer to <https://escies.org> for ESCC DCR content)

DCR No.	CHANGE DESCRIPTION
130	Specification upissued to incorporate technical and editorial changes per DCR.



TABLE OF CONTENTS

	<u>Page</u>
1. <u>GENERAL</u>	5
1.1 Scope	5
1.2 Component Type Variants	5
1.3 Maximum Ratings	5
1.4 Parameter Derating Information	5
1.5 Physical Dimensions	5
1.6 Circuit Schematic	5
2. <u>APPLICABLE DOCUMENTS</u>	5
3. <u>TERMS, DEFINITIONS, ABBREVIATIONS, SYMBOLS AND UNITS</u>	5
4. <u>REQUIREMENTS</u>	10
4.1 General	10
4.2 Deviations from Generic Specification	10
4.2.1 Deviations from Special In-Process Controls	10
4.2.2 Deviations from Final Production Tests	10
4.2.3 Deviations from Screening Tests	10
4.2.4 Deviations from Qualification Tests	10
4.2.5 Deviations from Lot Acceptance Tests	11
4.3 Mechanical Requirements	11
4.3.1 Dimension Check	11
4.3.2 Weight	11
4.3.3 Terminal Strength	12
4.4 Materials and Finishes	12
4.4.1 Case	12
4.4.2 Terminal Material and Finish	12
4.4.3 Mounting Studs	12
4.5 Marking	12
4.5.1 General	12
4.5.2 Terminal Identification	13
4.5.3 The ESCC Component Number	13
4.5.4 Electrical Characteristics	13
4.5.5 Traceability Information	13
4.6 Electrical Measurements	13
4.6.1 Electrical Measurements at Room Temperature	13
4.6.2 Electrical Measurements at High and Low Temperatures	13
4.6.3 Circuits for Electrical Measurements	13
4.7 Screening	13
4.7.1 Miss Test	13
4.7.2 Conditions for Screening	14
4.7.3 Electrical Circuits for Burn-in	14
4.8 Environmental and Endurance Tests	18
4.8.1 Measurements and Inspections on Completion of Environmental Tests	18
4.8.2 Measurements and Inspections during Endurance Tests	18
4.8.3 Measurements and Inspections on Completion of Endurance Tests	18
4.8.4 Conditions for Operating Life Tests	18
4.8.5 Electrical Circuits for Operating Life Tests	18



TABLES

	<u>Page</u>
1(a) Type Variants	6
1(b) Maximum Ratings	6
2 Electrical Measurements at Room Temperature	15
3 Electrical Measurements at High and Low Temperatures	16
4 Measurements during Screening	17
5(a) Conditions for Screening	17
5(b) Conditions for Operating Life Test	17
6 Measurements and Inspection on Completion of Environmental Tests and at Intermediate Points and on Completion of Endurance Testing	19

FIGURES

1 Parameter Derating Information	N/A
2 Physical Dimensions	7
3 Circuit Schematic	9
4 Circuits for Electrical Measurements	17
5(a) Electrical Circuits for Screening	17
5(b) Electrical Circuits for Operating Life Test	17

APPENDICES (Applicable to specific Manufacturers only)

None.

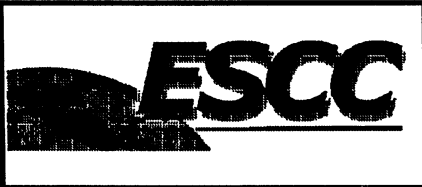

1. GENERAL

1.1 SCOPE

This specification details the ratings, physical and electrical characteristics, test and inspection data for a Relay, Electromagnetic Latching, 50Vdc, 50A, 1PDT with 1PDT auxilliary contacts 28Vdc, 2A. It shall be read in conjunction with ESCC Generic Specification No. 3602, the requirements of which are supplemented herein.

1.2 COMPONENT TYPE VARIANTS

Variants of the basic type relays specified herein which are also covered by this specification are given in Table 1(a).

1.3 MAXIMUM RATINGS

The maximum ratings, which shall not be exceeded at any time during use or storage, applicable to the relays applicable to the relays specified herein, are given in Table 1(b).

1.4 PARAMETER DERATING INFORMATION (FIGURE 1)

Not applicable.

1.5 PHYSICAL DIMENSIONS

The physical dimensions of the relays specified herein are shown in Figure 2.

1.6 CIRCUIT SCHEMATIC

The circuit schematic, showing lead identification etc. for the relays specified herein, is shown in Figure 3.

2. APPLICABLE DOCUMENTS

The following documents form part of this specification and shall be read in conjunction with it:-

- (a) ESCC Generic Specification No. 3602 for Relays, Electromagnetic, Latching,
- (b) MIL-STD-202, Test Methods for Electronic and Electrical Component Parts.

3. TERMS, DEFINITIONS, ABBREVIATIONS, SYMBOLS AND UNITS

For the purpose of this specification, the terms, definitions, abbreviations, symbols and units specified in ESCC Basic Specification No. 21300 shall apply.

TABLE 1(a) - TYPE VARIANTS

VARIANT	DESCRIPTION	FIGURE
01	Relay with 4 mounting studs	2(a)
04	Relay with side flange	2(b)

NOTES

- Variants 02 and 03 shall not be allocated.

TABLE 1(b) - MAXIMUM RATINGS

No.	CHARACTERISTICS	SYMBOL	MAXIMUM RATING	UNIT	REMARKS
1	Rated Coil Voltage:- 48V 28V 12V	V_{CR}	48 28 12	Vdc	Note 3
2	Maximum Rated Coil Voltage:- 48V 28V 12V	V_{CR}	45.5 to 55 26.5 to 32 11 to 14	Vdc	
3	Rated Contact Current Resistive Load	I_{CR}	Main: 50 Auxiliary: 2.0	A	50Vdc resistive 28Vdc resistive Note 1
4	Overload Current Resistive	I_{overL}	100 300	A	50Vdc resistive Table 6 28Vdc resistive
5	Rated Contact Current Inductive Load	I_{CL}	20	A	50Vdc inductive Note 1
6	Contact Resistance	R_C	2.5	m Ω	
7	High Temperature	T_{amb}	+ 125	$^{\circ}C$	
8	Low Temperature	T_{amb}	- 65	$^{\circ}C$	
9	Soldering Temperature	T_{sol}	+ 260	$^{\circ}C$	Note 2

NOTES

- Relays should not be used in change over-mode where the potential difference between stationary contacts is greater than 10V and the switched current is greater than 0.1A.
- Duration 10 seconds maximum at a distance of not less than 3.0mm from the device body and the same termination shall not be resoldered until 3 minutes have elapsed.
- The Coil Voltage rise time shall be less than $0.1t_L$ or t_r . The coil voltage shall be applied for a minimum time of $10t_L$ or $10t_r$.

FIGURE 2 - PHYSICAL DIMENSIONS

FIGURE 2(a) - VARIANT 01 - RELAY WITH 4 MOUNTING STUDS

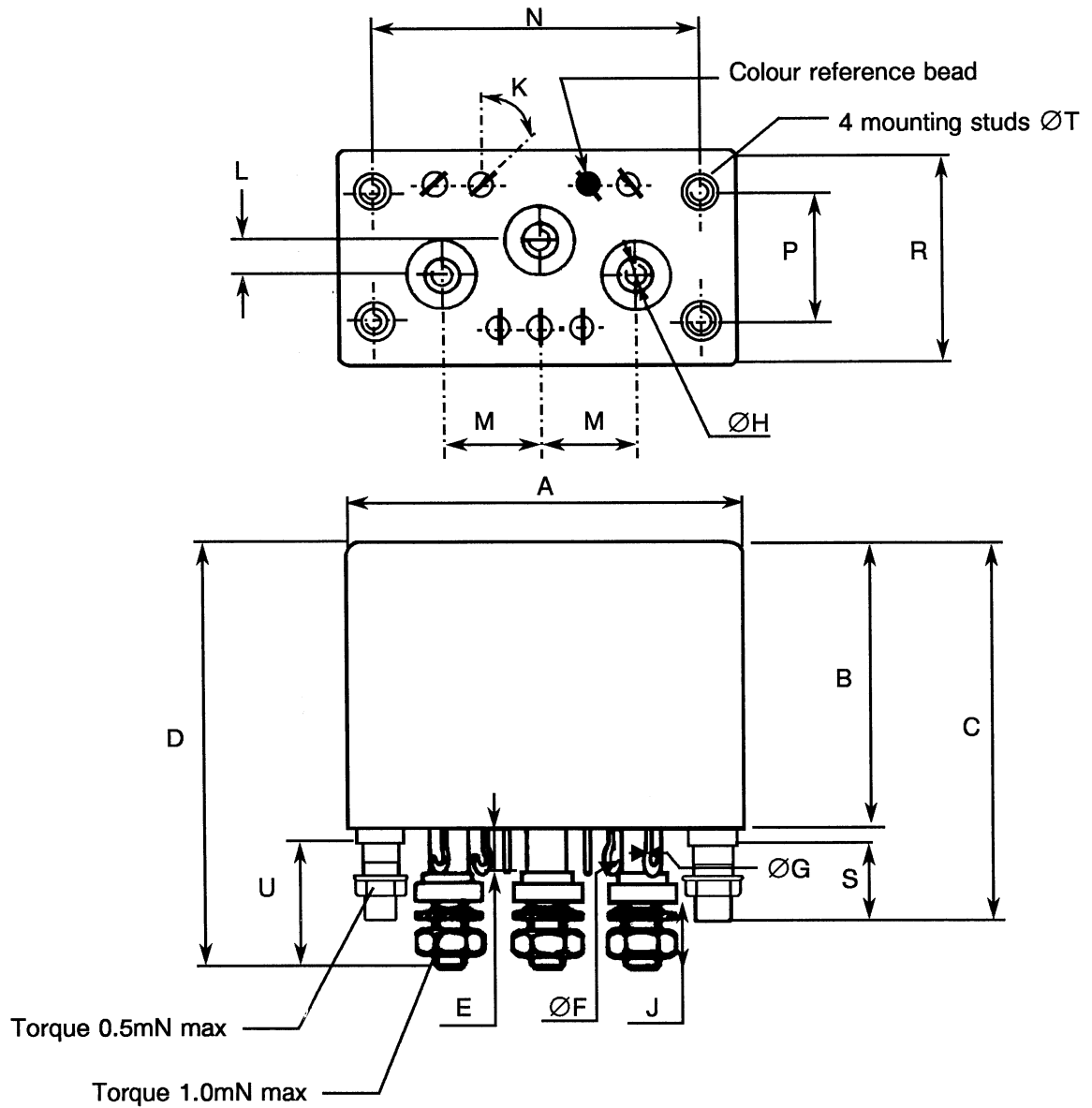

SYMBOL	A	B	C	D	E	ØF	ØG	ØH	J	K	L	M	N	P	R	S	ØT	U
MIN.	-	-	-	-	4.50	1.30	0.71	M4	8.40	40°	3.80	10.90	37.85	14.80	-	8.20	M3	15.00
MAX.	47.80	34.60	44.70	51.60	5.70	1.70	0.84	-	9.40	50°	4.40	11.50	38.35	15.35	26.20	8.80	-	16.50

NOTES

1. All dimensions are in millimetres.

FIGURE 2 - PHYSICAL DIMENSIONS (CONTINUED)

FIGURE 2(b) - VARIANT 04 - RELAY WITH SIDE FLANGE

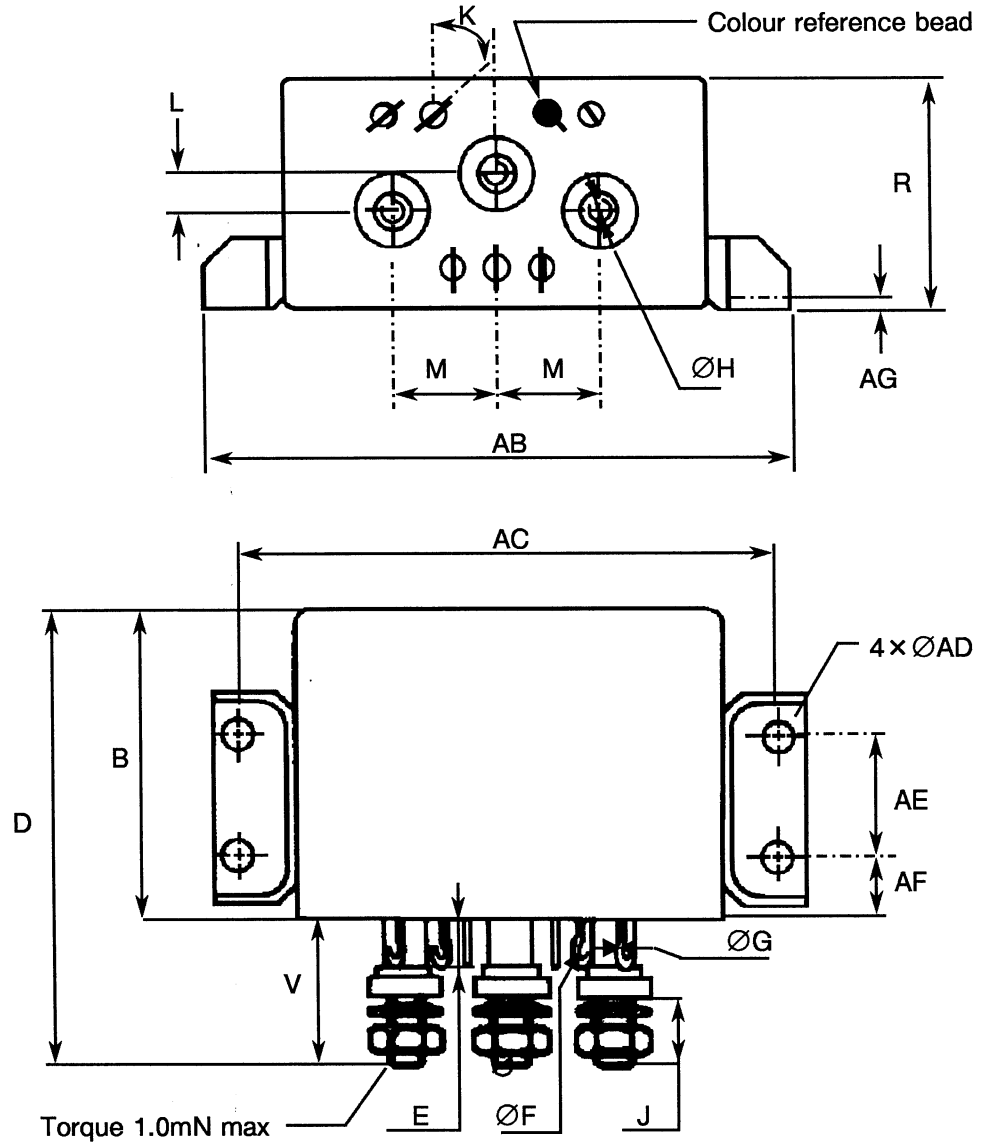

SYMBOL	B	D	E	ϕF	ϕG	ϕH	J	K	L	M	R	V	AB	AC	ϕAD	AE	AF	AG
MIN.	-	-	4.50	1.30	0.71	M4	8.40	40°	3.80	10.90	-	16.50	-	60.20	3.10	15.80	6.90	1.95
MAX.	34.60	51.60	5.70	1.70	0.84	-	9.40	50°	4.40	11.50	26.20	17.50	70.00	60.40	3.50	16.00	7.10	2.05

NOTES

1. All dimensions are in millimetres.

FIGURE 3 - CIRCUIT SCHEMATIC

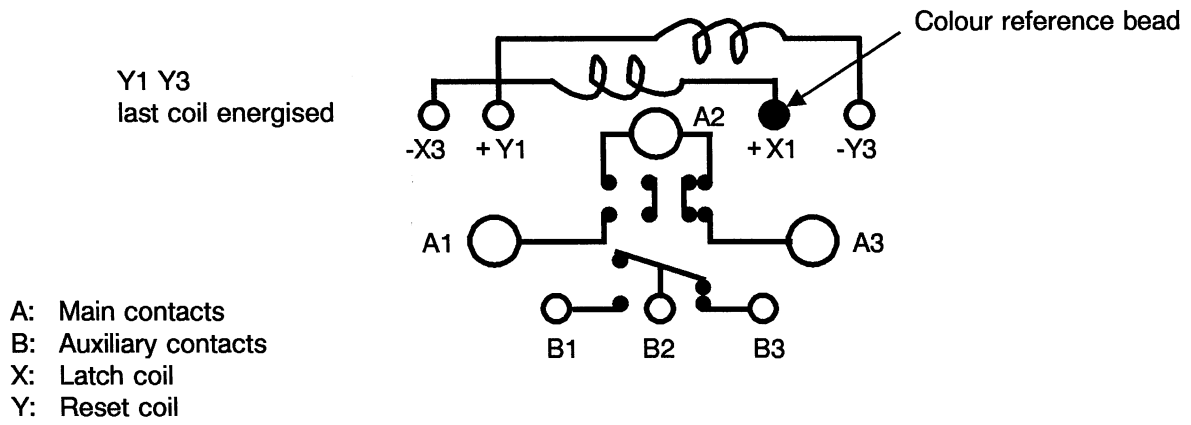

AS VIEWED FROM HEADER SIDE

4. REQUIREMENTS

4.1 GENERAL

The complete requirements for procurement of the relays specified herein are stated in this specification and ESCC Generic Specification No. 3602 for Relays, Electromagnetic Latching. Deviations from the Generic Specification, applicable to this specification only, are listed in Para 4.2.

Deviations from the applicable Generic Specification and this Detail Specification, formally agreed with specific Manufacturers on the basis that the alternative requirements are equivalent to the ESCC requirements and do not affect the components' reliability, are listed in the appendices attached to this specification.

4.2 DEVIATIONS FROM GENERIC SPECIFICATION

4.2.1 Deviations from Special In-process Controls

None.

4.2.2 Deviations from Final Production Tests (Chart II)

(a) Para. 9.3.3, Contact Voltage Drop: For main contacts, test current shall be 10A, 6.0Vdc.

4.2.3 Deviations from Screening Tests (Chart III)

(a) Para. 9.3.3, Contact Voltage Drop: For main contacts, test current shall be 10A, 6.0Vdc.

(b) Para. 9.4, Seal Test: Helium pressure: 2 bars absolute.
Pressurisation time: 5 hours.

(c) Para. 9.6, Vibration Scan:

- MIL-STD-202, Method 214, Test Condition II, Level E (Random Vibration).
- 1 minute in latch position, 1 minute in reset position.
- Vibration axis: 3 mutually perpendicular planes.

(d) Para. 9.8, Low Level Test (Miss Test):-

- Item (a) - Main contact loading: 1.0A maximum, 28Vdc resistive.
- Item (f) - 1000 operations at each temperature.

(e) Para. 9.9, Internal Moisture: Replace the third sentence by the following:-

"Both relay coils shall be energised at the same time with 125% of rated coil voltage for 30 minutes."

4.2.4 Deviations from Qualification Tests (Chart IV)

(a) Para. 9.3.3, Contact Voltage Drop: For main contacts, test current shall be 10A, 6.0Vdc.

(b) Para. 9.4, Seal Test: Helium pressure: 2 bars absolute.
Pressurisation time: 5 hours.

(c) Para. 9.10, Vibration: Item (b), Test Condition 'D'.

(d) Para. 9.11, Mechanical Shock: Test conditions: 100g, 11ms, $\frac{1}{2}$ sine-wave.

(e) Para. 9.12, Overload: Applicable to the main contacts only with the following loads:

- 3 samples: 300A, 28Vdc resistive.
- 3 samples: 100A, 50Vdc resistive.

: Separate tests shall be performed for the N/O and N/C contacts.

(f) Para. 9.16, Intermediate Current:-

- Item (a) - Main contacts: 5A, 50Vdc resistive.
- Auxiliary contacts: 100mA, 6.0Vdc resistive.

Item (f) - Number of operations: 10 000.

- (g) Para. 9.19.1, Resistive Life: Item (f) - Number of operations: 20 000.
- (h) Para. 9.19.2, Low Level Load and Mechanical Life: To be performed on Auxiliary contacts only:-
Item (f) - Number of operations: 5 000.
Simultaneously, an Inductive Life test shall be performed on the main contacts as specified in Para. 9.19.3:-
Item (c)- Cycling time shall be as per Para. 9.19.3(c).
For both sets of contacts, all operations shall be monitored.
- (i) Para. 9.19.4, Mechanical Life: Item (d) - Number of operations: 90 000 minimum.

4.2.5 Deviations from Lot Acceptance Tests (Chart V)

- (a) Para. 9.3.3, Contact Voltage Drop: For main contacts, test current shall be 10A, 6.0Vdc.
- (b) Para. 9.4, Seal Test: Helium pressure: 2 bars absolute.
Pressurisation time: 5 hours.
- (c) Para. 9.10, Vibration: Item (b), Test Condition 'D'.
- (d) Para. 9.11, Mechanical Shock: Test conditions: 100g, 11ms, $\frac{1}{2}$ sine-wave.
- (e) Para. 9.12, Overload: Applicable to the main contacts only with the following loads:
- 1 sample: 300A, 28Vdc resistive.
- 2 samples: 100A, 50Vdc resistive.
: Separate tests shall be performed for the N/O and N/C contacts.
- (f) Para. 9.16, Intermediate Current:-
Item (a)- Main contacts: 5A, 50Vdc resistive.
- Auxiliary contacts: 100mA, 6.0Vdc resistive.
Item (f) - Number of operations: 10 000.
- (g) Para. 9.19.1, Resistive Life: Item (f) - Number of operations: 20 000.
- (h) Para. 9.19.2, Low Level Load and Mechanical Life: To be performed on Auxiliary contacts only:-
Item (f) - Number of operations: 5 000.
Simultaneously, an Inductive Life test shall be performed on the main contacts as specified in Para. 9.19.3:-
Item (c)- Cycling time shall be as per Para. 9.19.3(c).
For both sets of contacts, all operations shall be monitored.
- (i) Para. 9.19.4, Mechanical Life: Item (d) - Number of operations: 90 000 minimum.

4.3 MECHANICAL REQUIREMENTS

4.3.1 Dimension Check

The dimensions of the relays specified herein shall be verified in accordance with the requirements set out in Para 9.5 of ESCC Generic Specification No. 3602 and shall conform to those shown in Figure 2.

4.3.2 Weight

The maximum weight of the relays specified herein shall be as specified hereafter :

VARIANT	WEIGHT (g)
01	150
04	165

4.3.3 Terminal Strength

The requirements for terminal strength testing are specified in Section 9 of ESCC Generic Specification No. 3602. The test conditions shall be as follows:-

(a) Pull Test

Applied Force: 15 Newtons for hook terminals .
50 Newtons for mounting studs (Variant 01 only).
160 Newtons for main contact terminals.

(b) Torque Test

In accordance with MIL-STD-202 Method 211 Test condition E:

Applied Torque: 0.65 Nm for mounting studs (Variant 01 only).
1.5 Nm for main contact terminals.

4.4 MATERIALS AND FINISHES

The materials and finishes shall be as specified herein. Where a definite material is not specified, a material which will enable the relays specified herein to meet the performance requirements of this specification shall be used. Acceptance or approval of any constituent material does not guarantee acceptance of the finished product.

4.4.1 Case

Copper nickel, welded construction, Sn/Pb plated. Neither electro-deposited tin nor any paint shall be used.

4.4.2 Terminal Material and Finish

For auxiliary contacts, the terminal material shall be Type 'H', with Type '3' finish and for main contacts the terminal material shall be Type 'O' both in accordance with the requirements of ESCC Basic Specification No. 23500.

Main contacts studs shall be equipped with stainless steel nuts and beryllium copper washers, both silver plated.

4.4.3 Mounting Studs (Variant 01 only)

Mounting studs shall be made of Fe-Ni alloy.

4.5 MARKING

4.5.1 General

The marking of all components delivered to this specification shall be in accordance with the requirements of ESCC Basic Specification No. 21700 and the following paragraphs. When the component is too small to accommodate all of the marking specified, as much as space permits shall be marked and the marking information, in full, shall accompany the component in its primary package.

The information to be marked and the order of precedence, shall be as follows:-

- (a) Terminal Identification.
- (b) The ESCC Component Number.
- (c) Electrical Characteristics.
- (d) Traceability Information.

4.5.2 Terminal Identification

Terminal identification shall be marked on the relay can in accordance with Figure 3.

4.5.3 The ESCC Component Number

Each component shall bear the ESCC Component Number which shall be constituted and marked as follows:-

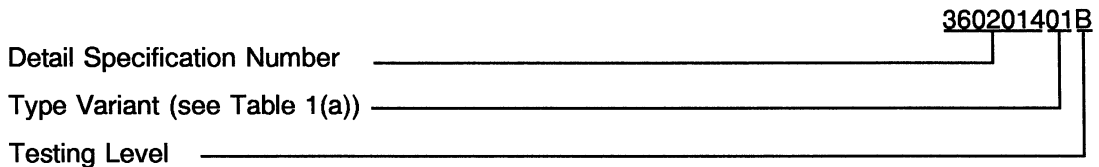

4.5.4 Electrical Characteristics

The electrical characteristic to be marked is the rated coil voltage. The information shall be constituted and marked as follows:-

Coil Voltage	Coil Resistance	Code
48Vdc	434Ω	48V
28Vdc	145Ω	28V
12Vdc	27Ω	12V

4.5.5 Traceability Information

Each component shall be marked in respect of traceability information in accordance with the requirements of ESCC Basic Specification No. 21700.

4.6 ELECTRICAL MEASUREMENTS

4.6.1 Electrical Measurements at Room Temperature

The parameters to be measured at room temperature are scheduled in Table 2. Unless otherwise specified, the measurements shall be performed at $T_{amb} = +22 \pm 3 \text{ }^\circ\text{C}$.

4.6.2 Electrical Measurements at High and Low Temperatures

The parameters to be measured at high and low temperatures are scheduled in Table 3.

4.6.3 Circuits for Electrical Measurements (Figure 4)

Not applicable.

4.7 SCREENING

4.7.1 Miss Test

During the miss test, the contact resistance shall be continuously monitored and not exceed the values specified in Table 4 of this specification.



4.7.2 Conditions for Screening

The requirements for screening are specified in Section 7 of ESCC Generic Specification No. 3602. The conditions for screening shall be as specified in Table 5(a) of this specification.

4.7.3 Electrical Circuits for Screening (Figure 5(a))

Not applicable.

TABLE 2 - ELECTRICAL MEASUREMENTS AT ROOM TEMPERATURE

No.	CHARACTERISTICS	SYMBOL	ESCC 3602 TEST METHOD	TEST CONDITION	LIMITS		UNIT
					MIN.	MAX.	
1	Latch Voltage:- 48V 28V 12V	U_L	Para. 9.3.1	Para. 9.3.1	14.3 9.1 3.6	24 14 6.0	V
2	Reset Voltage:- 48V 28V 12V	U_R	Para. 9.3.2	Para. 9.3.2	14.3 9.1 3.6	24 14 6.0	V
3	Latch Time	t_L	Para. 9.3.4	Para. 9.3.4	-	20	ms
4	Reset Time	t_r	Para. 9.3.4	Para. 9.3.4	-	20	ms
5	Bounce Time	t_B	Para. 9.3.4	Para. 9.3.4	-	2.0	ms
6	Insulation Resistance	R_i	Para. 9.3.7	Para. 9.3.7 at 500Vdc	100	-	MΩ
7	Voltage Proof	VP	Para. 9.3.6	Para. 9.3.6 Note 1	1250	-	Vrms
8	Contact Voltage Drop Main Contacts Auxiliary Contacts	V_d	Para. 9.3.3	Para. 9.3.3 10A - 6.0Vdc 100mA - 6.0Vdc	- -	25 5.0	mV
9	Coil Resistance Latch and Reset:- 48V 28V 12V	R_B	Para. 9.3.5	Para. 9.3.5	382 130 24	486 160 30	Ω

NOTES

- 1000V between coil and case, between open contacts, between coils.
500V between open auxiliary contacts..
- Limits Min. apply to measurements at -55°C and Limits Max. to +125°C.

TABLE 3 - ELECTRICAL MEASUREMENTS AT HIGH AND LOW TEMPERATURES

No.	CHARACTERISTICS	SYMBOL	ESCC 3602 TEST METHOD	TEST CONDITION	LIMITS		UNIT
					MIN.	MAX.	
1	Latch Voltage:- 48V 28V 12V	U_L	Para. 9.3.1	Para. 9.3.1	11 7.0 2.8	36 19.8 9.0	V
2	Reset Voltage:- 48V 28V 12V	U_R	Para. 9.3.2	Para. 9.3.2	11 7.0 2.8	36 19.8 9.0	V
3	Latch Time	t_L	Para. 9.3.4	Para. 9.3.4	-	20	ms
4	Reset Time	t_r	Para. 9.3.4	Para. 9.3.4	-	20	ms
5	Bounce Time	t_b	Para. 9.3.4	Para. 9.3.4	-	2.0	ms
6	Insulation Resistance	R_i	Para. 9.3.7	Para. 9.3.7 at 500Vdc Note 1	50	-	M Ω

NOTES

1. This measurement shall be made only at the high temperature condition.
2. Limits Min. apply to measurements at -55°C and Limits Max. to +125°C.

FIGURE 4 - CIRCUITS FOR ELECTRICAL MEASUREMENTS

Not applicable.

TABLE 4 - MEASUREMENTS DURING SCREENING

No.	CHARACTERISTICS	SYMBOL	ESCC 3602 TEST METHOD	TEST CONDITIONS	MAXIMUM LIMITS	UNIT
10	Miss Test, Contact Resistance	R _C	Para. 9.8	Para. 9.8	0.25 (1) 30 (2)	Ω

NOTES

1. Main contacts.
2. Auxiliary contacts.

TABLE 5(a) - CONDITIONS FOR SCREENING

No.	CHARACTERISTICS	SYMBOL	CONDITION	UNIT
1	Ambient High Temperature	T _{amb}	+ 125(+ 0 - 3)	°C
2	Ambient Low Temperature	T _{amb}	- 65(+ 3 - 0)	°C
3	Ambient Room Temperature	T _{amb}	+ 22 ± 3	°C

TABLE 5(b) - CONDITIONS FOR OPERATING LIFE TEST

No.	CHARACTERISTICS	SYMBOL	CONDITION	UNIT
1	Ambient High Temperature	T _{amb}	+ 125(+ 0 - 3)	°C
2	Contact Load, Resistive Main contacts	V	50	Vdc
		I	50	Adc
	Auxiliary contacts	V	28	Vdc
		I	2.0	Adc

FIGURE 5(a) - ELECTRICAL CIRCUITS FOR SCREENING

Not applicable.

FIGURE 5(b) - ELECTRICAL CIRCUITS FOR OPERATING LIFE TEST

Not applicable.

- 4.8 ENVIRONMENTAL AND ENDURANCE TESTS (CHARTS IV AND V OF ESCC GENERIC SPECIFICATION No. 3602)
- 4.8.1 Measurements and Inspections on Completion of Environmental Tests
The parameters to be measured and inspections to be performed on completion of environmental tests are scheduled in Table 6. Unless otherwise stated, the measurements shall be performed at $T_{amb} = +22 \pm 3 \text{ }^{\circ}\text{C}$.
- 4.8.2 Measurements and Inspections during Endurance Tests
The parameters to be measured and inspections to be performed during endurance tests are scheduled in Table 6. Unless otherwise stated, the measurements shall be performed at $T_{amb} = +22 \pm 3 \text{ }^{\circ}\text{C}$.
- 4.8.3 Measurements and Inspections on Completion of Endurance Tests
The parameters to be measured and inspections to be performed on completion of endurance tests are scheduled in Table 6. Unless otherwise stated, the measurements shall be performed at $T_{amb} = +22 \pm 3 \text{ }^{\circ}\text{C}$.
- 4.8.4 Conditions for Operating Life Tests (Part of Endurance Testing)
The requirements for operating life testing are specified in Section 9 of ESCC Generic Specification No. 3602. The conditions for operating life testing shall be as specified in Table 5(b) of this specification.
- 4.8.5 Electrical Circuits for Operating Life Tests (Figure 5(b))
Not applicable.



TABLE 6 - MEASUREMENTS AND INSPECTIONS ON COMPLETION OF ENVIRONMENTAL TESTS AND AT INTERMEDIATE POINTS AND ON COMPLETION OF ENDURANCE TESTING

No.	ESCC GENERIC SPEC. NO. 3602		MEASUREMENTS AND INSPECTIONS		SYMBOL	LIMITS		UNIT
	ENVIRONMENTAL AND ENDURANCE TESTS (1)	TEST METHOD AND CONDITIONS	IDENTIFICATION	CONDITIONS		MIN.	MAX.	
01	Vibration	Para. 9.10 and Para's. 4.2.4 and 4.2.5 of this spec.	Measurements during Test Contact Monitoring Final Measurements Visual Examination	ESCC 3602 Para. 9.10 -	- -	- -	- -	- -
02	Mechanical Shock	Para. 9.11 and Para's. 4.2.4 and 4.2.5 of this spec.	Measurements during Test Contact Monitoring Final Measurements Electrical Measurements Visual Examination	ESCC 3602 Para. 9.11 Table 2 Items 7-8-1-2 -	- -	- -	Table 2 -	- -
03	Overload	Para. 9.12 and Table 1(b) Item 4, Para's. 4.2.4 and 4.2.5 of this spec.	Measurements during Test Contact Voltage Drop (2) Final Measurements Fuse Continuity Contact Voltage Drop (2) Insulation Resistance Voltage Proof (all Points) (3) Electrical Measurements	ESCC 3602 Para. 9.12.3 - Table 2 Item 8 Table 2 Item 6 Table 2 Item 7 Table 2 Items 1-2-3-4-5-9	V _d - V _d R _i VP	Para. 9.12.3 - 250 50 1000 Table 2	- -	mV mV MΩ Vrms
04	Thermal Shock	Para. 9.13	During 5th Cycle Electrical Measurements at +125°C Electrical Measurements at -65°C Final Measurements Visual Examination Voltage Proof (all Points) (3)	In Conditioning Chamber Table 3 Items 1-2-3-4-6 Table 3 Items 1-2-3-4 - Table 2 Item 7	- -	- -	Table 3 Table 3 -	- -
05	Salt Spray	Para. 9.14	Final Measurements Visual Examination Electrical Measurements Voltage Proof (all Points) (3)	- Table 2 Items 1-2-3-4-5-6-8-9 Table 2 Item 7	- -	- -	Table 2 -	- -
06	Intermediate Current	Para. 9.16 and Para's. 4.2.4 and 4.2.5 of this spec.	Measurements during Test Contact Voltage Drop Final Measurements Insulation Resistance Voltage Proof (all Points) (3) Electrical Measurements Contact Voltage Drop	ESCC 3602 Para. 9.16.1 (4) Para. 9.16.3 (2) Table 2 Item 6 Table 2 Item 7 Table 2 Items 1-2-3-4-5-9 ESCC 3602 Para. 9.16.1 (4) Para. 9.16.3 (2)	V _d V _d R _i VP V _d V _d	Para. 9.16.1 Para. 9.16.3 50 1000 Table 2 Para. 9.16.1 Para. 9.16.3	- -	mV mV MΩ Vrms mV mV
07	Terminal Strength	Para. 9.17 and Para. 4.3.3 of this spec.	Visual Examination	ESCC 3602 Para. 9.17.3	-	-	-	-

NOTES

1. The tests in this table refer to either Chart IV or V and shall be used as applicable.
2. Main contacts.
3. 500Vrms between Auxiliary contacts.
4. Auxiliary contacts.



TABLE 6 - MEASUREMENTS AND INSPECTIONS ON COMPLETION OF ENVIRONMENTAL TESTS AND AT INTERMEDIATE POINTS AND ON COMPLETION OF ENDURANCE TESTING (CONT'D)

No.	ESCC GENERIC SPEC. NO. 3602		MEASUREMENTS AND INSPECTIONS		SYMBOL	LIMITS		UNIT
	ENVIRONMENTAL AND ENDURANCE TESTS (1)	TEST METHOD AND CONDITIONS	IDENTIFICATION	CONDITIONS		MIN.	MAX.	
08	Resistance to Soldering Heat	Para. 9.18	Electrical Measurements	Table 2 Items 1-2-6-8-9		Table 2		
09	Operating Life Resistive	Para's 9.19, 9.19.1 and Para's 4.2.4, 4.2.5 and Table 5(b) of this spec.	Measurements during Test Contact Voltage Drop Final Measurements Fuse Continuity Contact Voltage Drop Insulation Resistance Voltage Proof (all Points) (3) Electrical Measurements	ESCC 3602 Para. 9.19.1 - Table 2 Item 8 Table 2 Item 6 Table 2 Item 7 Table 2 Items 1-2-3-4-5-9	V_d - V_d Ri VP	Para. 9.19.1 Continuity - 250 (2) - 200 (4) 50 - Table 2	mV mV MΩ Vrms	
10	Operating Life Low Level Load and Mechanical Life (4)	Para. 9.19.2	Measurements during Test Contact Voltage Drop Final Measurements Contact Voltage Drop Insulation Resistance Voltage Proof (all Points) (3) Electrical Measurements	ESCC 3602 Para. 9.19.2 Table 2 Item 8 Table 2 Item 6 Table 2 Item 7 Table 2 Items 1-2-3-4-5-9	V_d V_d Ri VP	Para. 9.19.2 - 100 50 - 1000 - Table 2	mV mV MΩ Vrms	
11	Inductive Life (2)	Para. 9.19.3 and Table 1(b) Item 5, Para's 4.2.4 and 4.2.5 of this spec.	Measurements during Test Contact Voltage Drop Final Measurements Fuse Continuity Contact Voltage Drop (2) Insulation Resistance Voltage Proof (all Points) (3) Electrical Measurements	ESCC 3602 Para. 9.19.1 - Table 2 Item 8 Table 2 Item 6 Table 2 Item 7 Table 2 Items 1-2-3-4-5-9	V_d - V_d Ri VP	Para. 9.19.1 Continuity - 250 50 - 1000 - Table 2	mV mV MΩ Vrms	
12	Mechanical Life	Para. 9.19.4	Final Measurements Contact Voltage Drop Electrical Measurements	Table 2 Item 8 Table 2 Items 1-2-3-4-5-9		- 250 Table 2	mV	

NOTES

1. The tests in this table refer to either Chart IV or V and shall be used as applicable.
2. Main contacts.
3. 500Vrms between Auxiliary contacts.
4. Auxiliary contacts.