



Pages 1 to 21

CAPACITORS, FIXED, MULTIPLE LAYER, CERAMIC

DIELECTRIC, TYPE II,

BASED ON TYPE CNC31, CNC32, CNC33 and CNC34

ESCC Detail Specification No. 3001/037

Issue 1	June 2009
---------	-----------



Document Custodian: European Space Agency - see <https://escies.org>

LEGAL DISCLAIMER AND COPYRIGHT

European Space Agency, Copyright © 2009. All rights reserved.

The European Space Agency disclaims any liability or responsibility, to any person or entity, with respect to any loss or damage caused, or alleged to be caused, directly or indirectly by the use and application of this ESCC publication.

This publication, without the prior permission of the European Space Agency and provided that it is not used for a commercial purpose, may be:

- copied in whole, in any medium, without alteration or modification.
- copied in part, in any medium, provided that the ESCC document identification, comprising the ESCC symbol, document number and document issue, is removed.

DOCUMENTATION CHANGE NOTICE

(Refer to <https://escies.org> for ESCC DCR content)

DCR No.	CHANGE DESCRIPTION

TABLE OF CONTENTS

<u>1.</u>	<u>GENERAL</u>	<u>6</u>
1.1	Scope	6
1.2	Component Type Variants and Range of Components	6
1.3	Maximum Ratings	6
1.4	Parameter Derating Information	6
1.5	Physical Dimensions	6
1.6	Functional Diagram	6
<u>2.</u>	<u>APPLICABLE DOCUMENTS</u>	<u>6</u>
<u>3.</u>	<u>TERMS, DEFINITIONS, ABBREVIATIONS, SYMBOLS AND UNITS</u>	<u>6</u>
<u>4.</u>	<u>REQUIREMENTS</u>	<u>13</u>
4.1	General	13
4.2	Deviations from Generic Specification	14
4.2.1	Deviations from Special In-Process Controls	14
4.2.2	Deviations from Final Production Tests (Chart II)	14
4.2.3	Deviations from Burn-in and Electrical Measurements (Chart III)	14
4.2.4	Deviations from Qualification Tests (Chart IV)	14
4.2.5	Deviations from Lot Acceptance Tests (Chart V)	14
4.3	Mechanical Requirements	14
4.3.1	Dimension Check	14
4.3.2	Weight	14
4.3.3	Robustness of Terminations	15
4.4	Materials and Finishes	15
4.4.1	Case	15
4.4.2	Lead Material and Finish	15
4.5	Marking	15
4.5.1	General	15
4.5.2	The ESCC Component Number	15
4.5.3	Electrical Characteristics and Ratings	15
4.5.3.1	Capacitance Value	16
4.5.3.2	Tolerance	16
4.5.3.3	Rated Voltage	16
4.5.4	Traceability Information	16
4.6	Electrical Measurements	16
4.6.1	Electrical Measurements at Room Temperature	16
4.6.2	Electrical Measurements at High and Low Temperatures	17
4.6.3	Circuits for Electrical Measurements	17
4.7	Burn-in Tests	17
4.7.1	Parameter Drift Values	17
4.7.2	Conditions for Burn-in	17
4.7.3	Electrical Circuit for Burn-in (Figure 5)	17
4.8	Environmental and Endurance Tests (Charts IV and V of ESCC Generic Specification No. 3001)	18
4.8.1	Measurements and Inspections on Completion of Environmental Tests	18
4.8.2	Measurements and Inspections at Intermediate Points During Endurance Tests	18
4.8.3	Measurements and Inspections on Completion of Endurance Tests	18
4.8.4	Conditions for Operating Life (Part of Endurance Testing)	19
4.8.5	Electrical Circuit for Operating Life Tests (Figure 5)	19



1. GENERAL

1.1 SCOPE

This specification details the ratings, physical and electrical characteristics, test and inspection data for Capacitors, Fixed, Multiple Layer, Ceramic Dielectric, Type II, based on Type CNC31, CNC32, CNC33 and CNC34. It shall be read in conjunction with ESCC Generic Specification No. 3001, the requirements of which are supplemented herein.

1.2 COMPONENT TYPE VARIANTS AND RANGE OF COMPONENTS

The variants and the range of components covered by this specification are given in Table 1(a).

1.3 MAXIMUM RATINGS

The maximum ratings, which shall not be exceeded at any time during use or storage, applicable to the components specified herein, are as scheduled in Table 1(b).

1.4 PARAMETER DERATING INFORMATION

Not applicable.

1.5 PHYSICAL DIMENSIONS

The physical dimensions of the capacitors specified herein are shown in Figure 2.

1.6 FUNCTIONAL DIAGRAM

The functional diagram for the capacitors specified herein is shown in Figure 3.

2. APPLICABLE DOCUMENTS

The following documents form part of this specification and shall be read in conjunction with it:

- (a) ESCC Generic Specification No. 3001 for Capacitors, Fixed, Ceramic Dielectric, Types I and II.

3. TERMS, DEFINITIONS, ABBREVIATIONS, SYMBOLS AND UNITS

For the purpose of this specification, the terms, definitions, abbreviations, symbols and units specified in ESCC Basic specification No. 21300 shall apply.

Table 1(a) - TYPE VARIANTS AND RANGE OF COMPONENTS

Variant	Type	Total Number of Leads Note 1	Figure	Dimension H Max (mm) Note 2	Capacitance Range (µF) Note 3		Weight Max (g)
					16V Note 4	25V Note 4	
01	CNC31NE	4	2(a)	2.5	2.2 to 3.9	1.2 to 2.2	0.4
				4.8	4.7 to 6.8	2.7 to 4.7	0.8
				7	8.2 to 12	5.6 to 6.8	1.2

Variant	Type	Total Number of Leads Note 1	Figure	Dimension H Max (mm) Note 2	Capacitance Range (µF) Note 3		Weight Max (g)
					16V Note 4	25V Note 4	
02	CNC32NE	6	2(a)	2.5	2.7 to 4.7	1.8 to 3.3	0.5
				4.8	5.6 to 10	3.9 to 5.6	1
				7	12 to 15	6.8 to 10	2
03	CNC33NE	6	2(a)	2.5	4.7 to 8.2	3.3 to 5.6	1
				4.8	10 to 15	6.8 to 10	2
				7	18 to 22	12 to 15	3
				9.5	27 to 33	18 to 22	4
04	CNC34NE	8	2(a)	2.5	8.2 to 15	5.6 to 10	2
				4.8	18 to 27	12 to 18	4
				7	33 to 47	22 to 27	6
				9.5	56 to 68	33 to 39	8
05	CNC31PE	4	2(b)	2.5	2.2 to 3.9	1.2 to 2.2	0.4
				4.8	4.7 to 6.8	2.7 to 4.7	0.8
				7	8.2 to 12	5.6 to 6.8	1.2
06	CNC32PE	6	2(b)	2.5	2.7 to 4.7	1.8 to 3.3	0.5
				4.8	5.6 to 10	3.9 to 5.6	1
				7	12 to 15	6.8 to 10	2
07	CNC33PE	6	2(b)	2.5	4.7 to 8.2	3.3 to 5.6	1
				4.8	10 to 15	6.8 to 10	2
				7	18 to 22	12 to 15	3
				9.5	27 to 33	18 to 22	4
08	CNC34PE	8	2(b)	2.5	8.2 to 15	5.6 to 10	2
				4.8	18 to 27	12 to 18	4
				7	33 to 47	22 to 27	6
				9.5	56 to 68	33 to 39	8
09	CNC31PLE	4	2(c)	2.5	2.2 to 3.9	1.2 to 2.2	0.4
				4.8	4.7 to 6.8	2.7 to 4.7	0.8
				7	8.2 to 12	5.6 to 6.8	1.2
10	CNC32PLE	6	2(c)	2.5	2.7 to 4.7	1.8 to 3.3	0.5
				4.8	5.6 to 10	3.9 to 5.6	1
				7	12 to 15	6.8 to 10	2
11	CNC33PLE	6	2(c)	2.5	4.7 to 8.2	3.3 to 5.6	1
				4.8	10 to 15	6.8 to 10	2
				7	18 to 22	12 to 15	3
				9.5	27 to 33	18 to 22	4
12	CNC34PLE	8	2(c)	2.5	8.2 to 15	5.6 to 10	2
				4.8	18 to 27	12 to 18	4
				7	33 to 47	22 to 27	6
				9.5	56 to 68	33 to 39	8
13	CNC31LE	4	2(d)	2.5	2.2 to 3.9	1.2 to 2.2	0.4
				4.8	4.7 to 6.8	2.7 to 4.7	0.8
				7	8.2 to 12	5.6 to 6.8	1.2

Variant	Type	Total Number of Leads Note 1	Figure	Dimension H Max (mm) Note 2	Capacitance Range (μF) Note 3		Weight Max (g)
					16V Note 4	25V Note 4	
14	CNC32LE	6	2(d)	2.5	2.7 to 4.7	1.8 to 3.3	0.5
				4.8	5.6 to 10	3.9 to 5.6	1
				7	12 to 15	6.8 to 10	2
15	CNC33LE	6	2(d)	2.5	4.7 to 8.2	3.3 to 5.6	1
				4.8	10 to 15	6.8 to 10	2
				7	18 to 22	12 to 15	3
				9.5	27 to 33	18 to 22	4
16	CNC34LE	8	2(d)	2.5	8.2 to 15	5.6 to 10	2
				4.8	18 to 27	12 to 18	4
				7	33 to 47	22 to 27	6
				9.5	56 to 68	33 to 39	8

NOTES:

1. "DIL" format, with equal number of leads per side. See Figures 2 and 3.
2. See Figure 2.
3. The following Capacitance Values and Tolerances are available:
E12 ±10% (K)
E6 ±20% (M)
4. Maximum Rated Voltage, U_R .

Table 1(b) - MAXIMUM RATINGS

No.	Characteristics	Symbol	Maximum Ratings	Unit	Remarks
1	Rated Voltage	U_R	See Table 1(a)	V	
2	Operating Temperature Range	T_{op}	-55 to +125	°C	Without derating. T_{amb}
3	Storage Temperature Range	T_{stg}	-55 to +125	°C	
4	Soldering Temperature	T_{sol}	+260	°C	Note 1

NOTES:

1. Duration 10 seconds maximum and the same lead shall not be resoldered until 3 minutes have elapsed.

FIGURE 1 - PARAMETER DERATING INFORMATION

Not applicable

FIGURE 2 - PHYSICAL DIMENSIONS

FIGURE 2(a) - VARIANTS 01 TO 04
(Variant 04 shown for illustrative purposes)

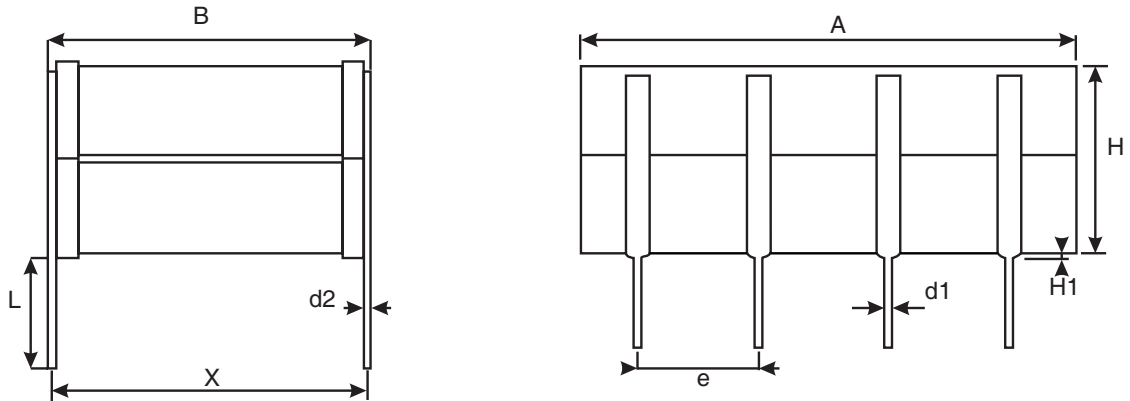

Variant	No. of Leads	Dimensions (mm)												
		A	B	d1 Note 1		d2 Note 1		e Note 2		H	H1 Note 1	L Note 1	X Note 1	
		Max	Max	Min	Max	Min	Max	Min	Max	Max	Max	Min	Min	Max
01	4	6	7.5	0.4	0.6	0.2	0.3	2.49	2.59	See Table 1(a)	2.05	7.5	4.58	5.58
02	6	8	8	0.4	0.6	0.2	0.3	2.49	2.59	See Table 1(a)	2.05	7.5	7.12	8.12
03	6	9.2	10	0.4	0.6	0.2	0.3	2.49	2.59	See Table 1(a)	2.05	7.5	7.12	8.12
04	8	12	12.5	0.4	0.6	0.2	0.3	2.49	2.59	See Table 1(a)	2.05	7.5	9.66	10.66

NOTES:

1. All leads.
2. Each space.

FIGURE 2(b) - VARIANTS 05 TO 08
(Variant 08 shown for illustrative purposes)

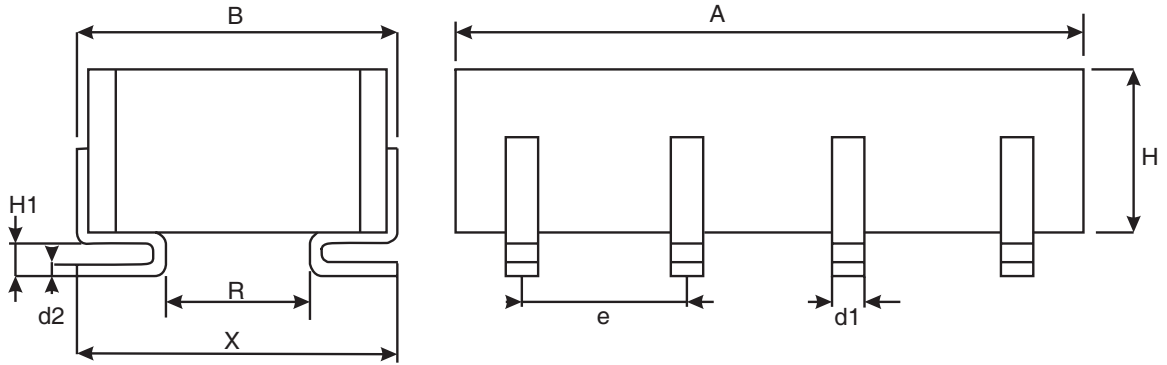

Variant	No. of Leads	Dimensions (mm)													
		A	B	d1 Note 1		d2 Note 1		e Note 2		H	H1 Note 1		R Note 1	X Note 1	
		Max	Max	Min	Max	Min	Max	Min	Max	Max	Min	Max	Min	Min	Max
05	4	6	7.5	0.4	0.6	0.2	0.3	2.49	2.59	See Table 1(a)	1.1	1.6	2.5	5.5	7.5
06	6	8	8	0.4	0.6	0.2	0.3	2.49	2.59	See Table 1(a)	1.1	1.6	2.5	6	8
07	6	9.2	10	0.4	0.6	0.2	0.3	2.49	2.59	See Table 1(a)	1.1	1.6	3.5	8	10
08	8	12	12.5	0.4	0.6	0.2	0.3	2.49	2.59	See Table 1(a)	1.1	1.6	5	9.5	12.5

NOTES:

1. All leads.
2. Each space.

FIGURE 2(c) - VARIANTS 09 TO 12
(Variant 12 shown for illustrative purposes)

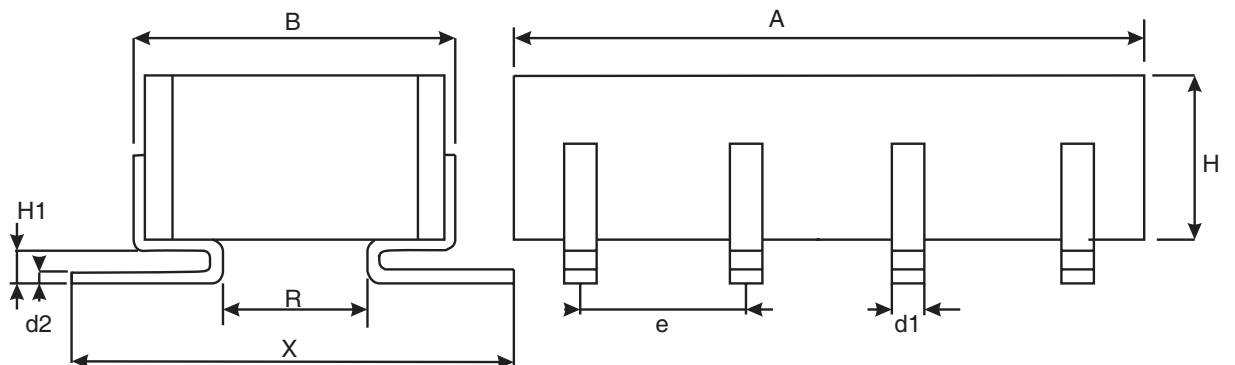

Variant	No. of Leads	Dimensions (mm)													
		A	B	d1 Note 1		d2 Note 1		e Note 2		H	H1 Note 1		R Note 1	X Note 1	
		Max	Max	Min	Max	Min	Max	Min	Max	Max	Min	Max	Min	Min	Max
09	4	6	7.5	0.4	0.6	0.2	0.3	2.49	2.59	See Table 1(a)	1.1	1.6	2.5	9.5	13.5
10	6	8	8	0.4	0.6	0.2	0.3	2.49	2.59	See Table 1(a)	1.1	1.6	2.5	10	14
11	6	9.2	10	0.4	0.6	0.2	0.3	2.49	2.59	See Table 1(a)	1.1	1.6	3.5	12	16
12	8	12	12.5	0.4	0.6	0.2	0.3	2.49	2.59	See Table 1(a)	1.1	1.6	5	13.5	18.5

NOTES:

1. All leads.
2. Each space.

FIGURE 2(d) - VARIANTS 13 TO 16
(Variant 16 shown for illustrative purposes)

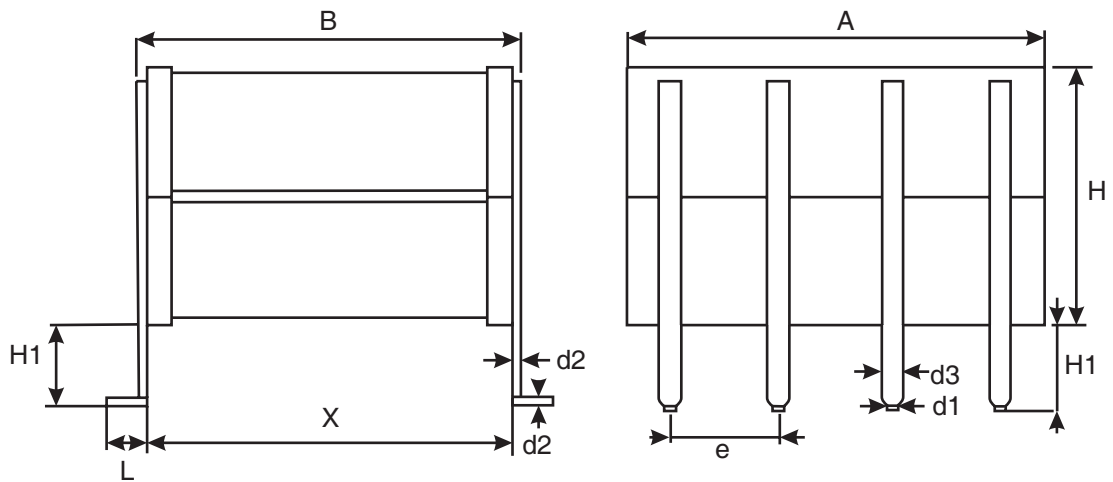

Variant	No. of Leads	Dimensions (mm)																
		A	B	d1 Note 1		d2 Note 1		d3 Note 1		e Note 2	H	H1 Note 1		L Note 1		X Note 1		
		Max	Max	Min	Max	Min	Max	Min	Max	Min	Max	Max	Min	Max	Min	Max	Min	Max
13	4	6	7.5	0.4	0.6	0.2	0.3	0.9	1.1	2.49	2.59	See Table 1(a)	2	3	2	3	5	7

Variant	No. of Leads	Dimensions (mm)																
		A	B	d1 Note 1		d2 Note 1		d3 Note 1		e Note 2		H	H1 Note 1		L Note 1		X Note 1	
		Max	Max	Min	Max	Min	Max	Min	Max	Min	Max	Max	Min	Max	Min	Max	Min	Max
14	6	8	8	0.4	0.6	0.2	0.3	0.9	1.1	2.49	2.59	See Table 1(a)	2	3	2	3	5.5	7.5
15	6	9.2	10	0.4	0.6	0.2	0.3	0.9	1.1	2.49	2.59	See Table 1(a)	2	3	2	3	7.5	9.5
16	8	12	12.5	0.4	0.6	0.2	0.3	0.9	1.1	2.49	2.59	See Table 1(a)	2	3	2	3	10	12

NOTES:

1. All leads.
2. Each space.

FIGURE 3 - FUNCTIONAL DIAGRAM

Variants 01, 05, 09 and 13

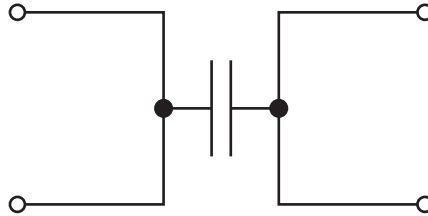

Variants 02, 03, 06, 07, 10, 11, 14 and 15

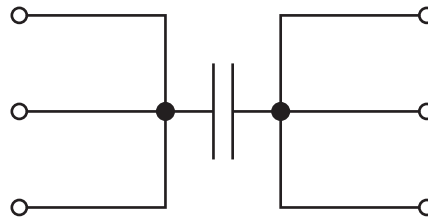

Variants 04, 08, 12 and 16

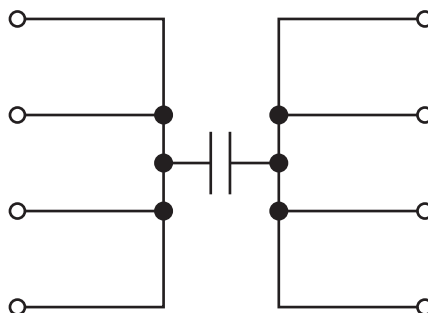
**4. REQUIREMENTS****4.1 GENERAL**

The complete requirements for procurement of the components specified herein are stated in this

specification and ESCC Generic Specification No. 3001 for Capacitors, Fixed, Ceramic Dielectric, Types I and II. Deviations from the Generic Specification, applicable to this specification only, are detailed in Para. 4.2.

Deviations from the Generic Specification and this Detail Specification, formally agreed with specific Manufacturers on the basis that the alternative requirements are equivalent to the ESCC requirements and do not affect the components' reliability, are listed in the appendices attached to this specification.

4.2 DEVIATIONS FROM GENERIC SPECIFICATION

4.2.1 Deviations from Special In-Process Controls

None.

4.2.2 Deviations from Final Production Tests (Chart II)

None.

4.2.3 Deviations from Burn-in and Electrical Measurements (Chart III)

(a) Para. 9.6, Radiographic Inspection: Not applicable.

4.2.4 Deviations from Qualification Tests (Chart IV)

(a) Para. 9.8, Resistance to Soldering Heat: Shall be performed before Para. 9.7, Robustness of Terminations.

Variants 01 to 04

Leads shall be immersed to between 2mm and 2.5mm from the body.

Variants 05 to 16

Only the part of the lead designed to be soldered shall be tested.

(b) Para. 9.11, Vibration: Prior to testing, capacitors shall be mounted onto a suitable substrate. The test samples shall be glued and cured prior to soldering to avoid any stress.

(c) Para. 9.12, Shock or Bump: The test samples shall be mounted as for the vibration test.

4.2.5 Deviations from Lot Acceptance Tests (Chart V)

(a) Para. 9.8, Resistance to Soldering Heat: As per Para. 4.2.4(a) of this specification.

(b) Para. 9.11, Vibration: As per Para. 4.2.4(b) of this specification.

(c) Para. 9.12, Shock or Bump: As per Para. 4.2.4(c) of this specification.

4.3 MECHANICAL REQUIREMENTS

4.3.1 Dimension Check

The dimensions of the components specified herein shall be verified in accordance with the requirements set out in Para. 9.4 of ESCC Generic Specification No. 3001 and they shall conform to those shown in Figure 2 of this specification.

4.3.2 Weight

The maximum weight of the components specified herein shall be as given in Table 1(a).

4.3.3 Robustness of Terminations

The terminations of these devices are defined as rigid. The requirements for the robustness of terminations are specified in Para. 9.7 of ESCC Generic Specification No. 3001.

4.4 MATERIALS AND FINISHES

The materials and finishes shall be as specified herein. Where a definite material is not specified, a material which will enable the capacitors specified herein to meet the performance requirements of this specification shall be used. Acceptance or approval of any constituent material does not guarantee acceptance of the finished product.

4.4.1 Case

Variants 01 to 04 shall be coated with varnish.
Variants 05 to 16 are classified as non-insulated.

4.4.2 Lead Material and Finish

The lead material shall be type A with type 10 finish in accordance with the requirements of ESCC Basic Specification No. 23500.

4.5 MARKING

4.5.1 General

The marking of all components delivered to this specification shall be in accordance with the requirements of ESCC Basic Specification No. 21700 and the following paragraphs. When the component is too small to accommodate all of the marking specified, as much as space permits shall be marked and the marking information, in full, shall accompany each component in its primary package.

The information to be marked and the order of precedence, shall be as follows:

- (a) The ESCC Component Number.
- (b) Electrical Characteristics and Ratings.
- (c) Traceability Information.

4.5.2 The ESCC Component Number

The ESCC Component Number shall be constituted and marked as follows:

300103701B

- Detail Specification Number: 3001037
- Type Variant (see Table 1(a)): 01
- Testing Level (B or C, as applicable): B

4.5.3 Electrical Characteristics and Ratings

The electrical characteristics and ratings to be marked in the following order of precedence are:

- (a) Capacitance Value.
- (b) Tolerance.
- (c) Rated Voltage.

The information shall be constituted and marked as follows:

Example: 226KA

- Capacitance Value (22 μ F): 226
- Tolerance ($\pm 10\%$): K
- Rated Voltage (25V): A

4.5.3.1 *Capacitance Value*

The capacitance value shall be expressed by means of the following codes. The unit quantity for marking shall be in picofarads.

Capacitance Value (pF)	Code
XX10 ⁵	XX5
XX10 ⁶	XX6

4.5.3.2 *Tolerance*

The tolerance on capacitance value shall be indicated by the code letters specified hereafter.

Tolerance (%)	Code Letter
± 10	K
± 20	M

4.5.3.3 *Rated Voltage*

The rated voltage shall be indicated by the code letters specified hereafter.

Rated Voltage (V)	Code Letter
16	X
25	A

4.5.4 Traceability Information

Traceability information shall be marked in accordance with the requirements of ESCC Basic Specification No. 21700.

4.6 ELECTRICAL MEASUREMENTS

4.6.1 Electrical Measurements at Room Temperature

The parameters to be measured at room temperature are scheduled in Table 2. Unless otherwise specified the measurements shall be performed at $T_{amb} = +22 \pm 3^{\circ}\text{C}$.

4.6.2 Electrical Measurements at High and Low Temperatures

The parameters to be measured at high and low temperatures are scheduled in Table 3. Unless otherwise specified the measurements shall be performed at $T_{amb} = +125(+0 -5)^{\circ}C$ and $-55(+5 -0)^{\circ}C$ respectively.

4.6.3 Circuits for Electrical Measurements

Not applicable.

4.7 BURN-IN TESTS

4.7.1 Parameter Drift Values

The parameter drift values applicable to Burn-in are as specified in Table 4 of this specification. Unless otherwise stated, measurements shall be performed at $T_{amb}=+22\pm3^{\circ}C$.

The parameter drift values (Δ) applicable to the parameters scheduled shall not be exceeded. In addition to these drift value requirements for a given parameter, the appropriate limit values specified in Table 2 shall not be exceeded.

4.7.2 Conditions for Burn-in

The requirements for Burn-in are specified in Section 7 of ESCC Generic Specification No. 3001. The conditions for Burn-in shall be as specified in Table 5 of this specification.

Upon completion of Burn-in, a recovery period of 24 ± 2 hours is necessary before performance of the end-measurements.

4.7.3 Electrical Circuit for Burn-in (Figure 5)

Not applicable

Table 2 - ELECTRICAL MEASUREMENTS AT ROOM TEMPERATURE

No.	Characteristics	Symbol	ESCC 3001 Test Conditions	Limits		Unit	Remarks
				Min	Max		
1	Capacitance	C	Para. 9.5.1.1	See Table 1(a)		μF	
2	Tangent of Loss Angle	$Tg\delta$	Para. 9.5.1.2	-	250×10^{-4}	-	
3	Insulation Resistance	$R_i \times C$	Para. 9.5.1.3	1000	-	s	Note 1
4	Voltage Proof-Dielectric	VP	Para. 9.5.1.4	$2.5U_R$	-	V	Note 1

NOTES:

1. Variants 05 to 16 are classified as non-insulated.

Table 3 - ELECTRICAL MEASUREMENTS AT HIGH AND LOW TEMPERATURES

No.	Characteristics	Symbol	ESCC 3001 Test Conditions	Limits		Unit	Remarks
				Min	Max		
3	Insulation Resistance	$R_i \times C$	Para. 9.5.1.3 $T_{amb} = +125(+0 -5)^{\circ}C$	100	-	s	Notes 1, 2 and 3

No.	Characteristics	Symbol	ESCC 3001 Test Conditions	Limits		Unit	Remarks
				Min	Max		
5	Temperature Characteristic	TCC	Para. 9.17 $V_T=0V$ $V_T=U_R$	-20 -50	+20 +30	%	5 parts for each lot Note 4

NOTES:

1. Single sample. Inspection Level S3, AQL 2.5%.
2. Variants 05 to 16 are classified as non-insulated.
3. Applicable to Level 'B' only.
4. If 1 failure occurs out of the 5 parts, then test 100%. 1% reject maximum allowed in the case of 100% testing.

FIGURE 4 - CIRCUITS FOR ELECTRICAL MEASUREMENTS

Not applicable.

Table 4 - PARAMETER DRIFT VALUES

No.	Characteristics	Symbol	Spec. and/or Test Method	Test Conditions	Change Limits (Δ)	Unit
1	Capacitance Change	$\Delta C/C$	As per Table 2	As per Table 2	± 10	%

Table 5 - CONDITIONS FOR BURN-IN AND OPERATING TESTS

No.	Characteristics	Symbol	Condition	Unit
1	Ambient Temperature	T_{amb}	+125(+0 -3)	$^{\circ}C$
2	Test Voltage	V_T	$2U_R$	V

FIGURE 5 - ELECTRICAL CIRCUIT FOR BURN-IN AND OPERATING LIFE

Not applicable.

4.8 ENVIRONMENTAL AND ENDURANCE TESTS (CHARTS IV AND V OF ESCC GENERIC SPECIFICATION NO. 3001)

4.8.1 Measurements and Inspections on Completion of Environmental Tests

The parameters to be measured and inspections to be performed on completion of environmental tests are scheduled in Table 6. Unless otherwise stated, the measurements shall be performed at $T_{amb}=+22\pm 3^{\circ}C$.

4.8.2 Measurements and Inspections at Intermediate Points During Endurance Tests

The parameters to be measured and inspections to be performed at intermediate points during endurance tests are scheduled in Table 6. Unless otherwise stated, the measurements shall be performed at $T_{amb}=+22\pm 3^{\circ}C$.

4.8.3 Measurements and Inspections on Completion of Endurance Tests

The parameters to be measured and inspections to be performed on completion of endurance tests are scheduled in Table 6. Unless otherwise stated, the measurements shall be performed at $T_{amb}=+22\pm 3^{\circ}C$.

4.8.4 Conditions for Operating Life (Part of Endurance Testing)

The requirements for Operating Life testing are specified in Section 9 of ESCC Generic Specification No. 3001. The conditions for Operating Life testing shall be as specified in Table 5 for the Burn-in test.

4.8.5 Electrical Circuit for Operating Life Tests (Figure 5)

Not applicable.

Table 6 - MEASUREMENTS AND INSPECTIONS ON COMPLETION OF ENVIRONMENTAL TESTS AND AT INTERMEDIATE POINTS AND ON COMPLETION OF ENDURANCE TESTING

No.	ESCC Generic Spec. No. 3001		Measurements and Inspections		Symbol	Limits		Unit
	Environmental and Endurance Tests (Note 1)	Test Methods and Conditions	Identification	Conditions		Min	Max	
01	Robustness of Terminations	Para. 9.7 and Para. 4.3.3 of this spec.	Visual Examination	-	-	-	-	-
02	Resistance to Soldering Heat	Para. 9.8 and Paras 4.2.4 and 4.2.5 of this spec.	<u>Initial Measurements</u> Capacitance	Table 2 Item 1	C	Table 2 Item 1		μF
			<u>Final Measurements</u>	After a recovery period of 24 ±2hrs				
			Capacitance Change	Table 2 Item 1	ΔC/C	-15	+15	%
			Insulation Resistance	Table 2 Item 3	Ri x C	Table 2 Item 3		s
03	Solderability	Para. 9.9	Visual Examination	-	-	-	-	-
04	Rapid Change of Temperature	Para. 9.10	<u>Initial Measurements</u> Capacitance	Table 2 Item 1	C	Table 2 Item 1		μF
			<u>Final Measurements</u>	After a recovery period of 24 ±2hrs				
			Visual Examination	-	-	-	-	-
			Capacitance Change	Table 2 Item 1	ΔC/C	-15	+15	%
			Tangent of Loss Angle	Table 2 Item 2	Tgδ	Table 2 Item 2		-
05	Vibration	Para. 9.11 and Paras 4.2.4 and 4.2.5 of this spec.	<u>During Last Cycle</u> Electrical Measurement	Para. 9.11.3 of ESCC 3001	-	-	-	-
			<u>After Test</u>		-	-	-	-
			Visual Examination	-				
06	Shock or Bump	Para. 9.12 and Paras 4.2.4 and 4.2.5 of this spec.	Visual Examination	-	-	-	-	-
07	Climatic Sequence	Para. 9.13	<u>Initial Measurements</u> Capacitance	Table 2 Item 1	C	Table 2 Item 1		μF
			<u>Final Measurements</u>	After a recovery period of 1 to 24hrs				
			External Visual Inspection	Para. 9.3 of ESCC 3001	-	-	-	-
			Capacitance Change	Table 2 Item 1	ΔC/C	-10	+10	%
			Tangent of Loss Angle	Table 2 Item 2	Tgδ	Table 2 Item 2		-
			Insulation Resistance	Table 2 Item 3	Ri x C	30	-	s

No.	ESCC Generic Spec. No. 3001		Measurements and Inspections		Symbol	Limits		Unit
	Environmental and Endurance Tests (Note 1)	Test Methods and Conditions	Identification	Conditions		Min	Max	
08	Damp Heat, Steady State	Para. 9.14	<u>Initial Measurements</u> Capacitance	Table 2 Item 1	C	Table 2 Item 1		μF
			<u>Final Measurements</u>	After a recovery period of 24 ±2hrs	-	-	-	-
			Visual Examination	-	-	-	-	-
			Capacitance Change	Table 2 Item 1	ΔC/C	-10	+10	%
			Tangent of Loss Angle	Table 2 Item 2	Tgδ	Table 2 Item 2		-
			Insulation Resistance	Table 2 Item 3	Ri x C	30	-	s
09	Operating Life	Para. 9.15 Capacitance Change limits are related to Initial (0- hour) measurements	<u>Initial Measurements</u> Capacitance	Table 2 Item 1	C	Table 2 Item 1		μF
			<u>Intermediate Measurements</u> Capacitance Change	After a recovery period of 24 ±2hrs	ΔC/C	-15	+15	%
			Insulation Resistance	Table 2 Item 3	Ri x C	100	-	s
			<u>Final Measurements</u> Capacitance Change	After a recovery period of 24 ±2hrs	ΔC/C	-20	+20	%
			Tangent of Loss Angle	Table 2 Item 2	Tgδ	Table 2 Item 2		-
			Insulation Resistance	Table 2 Item 3	Ri x C	100	-	s
			Voltage Proof-Dielectric	Table 2 Item 4	VP	Table 2 Item 4		-
			Visual Examination	-	-	-	-	-
10	Temperature Characteristic	Para. 9.17	Temperature Characteristic	Table 3 Item 5	TCC	Table 3 Item 5		%

NOTES:

1. The tests in this Table refer to either Chart IV or V and shall be used as applicable.

APPENDIX 'A'

Agreed Deviations for Eurofarad (F)

Items Affected	Description of Deviations
<p>Deviations from Special In-Process Controls, Qualification and Lot Acceptance Tests.</p>	<p>Paras. 5.2.3 and 9.7 of ESCC Generic Specification No. 3001, Robustness of Terminations.</p> <p>Robustness of Terminations shall not be performed during Production Control - Special In-Process Controls.</p> <p>Robustness of Terminations shall be performed every two years as part of Maintenance of Qualification (Lot Acceptance Testing Level 1). This test shall be performed with the following conditions:</p> <p><u>Variants 01 to 04</u> As Para. 9.7 except only the Ua test shall be performed and a minimum of one randomly selected lead per side tested. The applied force shall be 5N.</p> <p><u>Variants 05 to 16</u> Capacitors shall be mounted on a suitable substrate. After mounting, examination shall be made for good tinning as evidence by flowing of the solder with wetting of the terminations. A force of 10N shall be applied normal to one lead-out side and in a plane parallel to the substrate, for a duration of 10 seconds. After the test, there shall be no evidence of damage to the components or loosening of the components from the substrate.</p>