



Pages 1 to 19

**POLYIMIDE INSULATED WIRES AND CABLES,
LOW FREQUENCY, 600V, - 200 TO + 200 °C,
BASED ON TYPE SPB 2110**

ESCC Detail Specification No. 3901/008

**ISSUE 2
May 2005**



Document Custodian: European Space Agency - see <https://escies.org>

	ESCC Detail Specification No. 3901/008	PAGE i ISSUE 2
---	---	-------------------

LEGAL DISCLAIMER AND COPYRIGHT

European Space Agency, Copyright © 2005. All rights reserved.

The European Space Agency disclaims any liability or responsibility, to any person or entity, with respect to any loss or damage caused, or alleged to be caused, directly or indirectly by the use and application of this ESCC publication.

This publication, without the prior permission of the European Space Agency and provided that it is not used for a commercial purpose, may be:

- copied in whole in any medium without alteration or modification.
- copied in part, in any medium, provided that the ESCC document identification, comprising the ESCC symbol, document number and document issue, is removed.

DOCUMENTATION CHANGE NOTICE

(Refer to <https://escies.org> for ESCC DCR content)

DCR No.	CHANGE DESCRIPTION
170	Specification upissued to incorporate technical and editorial changes per DCR.

	<p style="text-align: center;">ESCC Detail Specification No. 3901/008</p>		<p>PAGE 3 ISSUE 2</p>
---	---	--	---------------------------

TABLE OF CONTENTS

		<u>Page</u>
1.	<u>GENERAL</u>	5
1.1	Scope	5
1.2	Type Variants	5
1.3	Maximum Ratings	5
1.4	Parameter Derating Information	5
1.5	Physical Characteristics	5
1.6	Functional Diagram	5
2.	<u>APPLICABLE DOCUMENTS</u>	11
3.	<u>TERMS, DEFINITIONS, ABBREVIATIONS, SYMBOLS AND UNITS</u>	11
4.	<u>REQUIREMENTS</u>	11
4.1	General	11
4.2	Deviations from Generic Specification	11
4.2.1	Deviations from Special In-process Controls	11
4.2.2	Deviations from Final Production Tests	11
4.2.3	Deviations from Burn-in and Electrical Measurements	11
4.2.4	Deviations from Qualification Tests	11
4.2.5	Deviations from Lot Acceptance Tests	11
4.3	Mechanical Requirements	12
4.3.1	Dimension Check	12
4.3.2	Weight	12
4.4	Materials and Finishes	13
4.4.1	Conductor	13
4.4.2	Insulation	13
4.4.3	Shield	13
4.4.4	Jacket	14
4.4.5	Construction of Multicore Cables	14
4.4.6	Colour Coding	14
4.5	Marking	15
4.5.1	General	15
4.5.2	The ESCC Component Number	15
4.5.3	Characteristics	16
4.5.4	Traceability Information	16
4.5.5	Additional Marking	16
4.6	Electrical Measurements	16
4.6.1	Electrical Measurements at Room Temperature	16
4.6.2	Electrical Measurements at High and Low Temperatures	16
4.6.3	Circuits for Electrical Measurements	16
4.7	Burn-in Tests	16
4.8	Environmental and Endurance Tests	16
4.8.1	Mechanical Properties of Conductor	16
4.8.2	Accelerated Ageing	16
4.8.3	Wrap Test at Ambient Temperature	17
4.8.4	Voltage Test	18
4.8.5	Shrinkage	18
4.8.6	Blocking	18
4.8.7	Cold Bend Test	18



	<u>Page</u>
4.8.8 Cut-through Resistance	18
4.8.9 Notch Resistance	18
4.8.10 Flammability	18
4.8.11 Resistance to Fluids	18
4.8.12 Surface Resistance	18
4.8.13 Abrasion Resistance	19
4.8.14 Soldering	19
4.8.15 Solderability	19
4.8.16 Radiation Resistance	19
4.8.17 Overload Resistance	19
4.8.18 Long-term Ageing Test	19
4.8.19 Anthony and Brown Test	19

TABLES

1(a) Type Variants	6
1(b) Maximum Ratings	9
A Mandrel Diameters and Loads for Finished Wires	17
B Mandrel Diameters and Loads for Shielded and Jacketed Cables	17
C Mandrel Diameters and Loads for Finished Wires or Cores	18
2 Electrical Measurements at Room Temperature	19

FIGURES

1 Parameter Derating Information	9
2 Physical Characteristics	10

APPENDICES (Applicable to specific Manufacturers only)

None.

	<p style="text-align: center;">ESCC Detail Specification No. 3901/008</p>		<p>PAGE 5 ISSUE 2</p>
---	---	--	---------------------------

1. **GENERAL**

1.1 **SCOPE**

This specification details the ratings, physical and electrical characteristics, test and inspection data for Polyimide Insulated Wires and Cables, Low Frequency, 600V, -200 to +200 °C, based on Type SPB 2110. It shall be read in conjunction with ESCC Generic Specification No. 3901, the requirements of which are supplemented herein.

NOTES

1. These wires and cables shall not be used in the presence or vicinity of hydrazine or nitrogen tetroxide.

1.2 **TYPE VARIANTS**

Variants of the basic types of wires and cables specified herein which are also covered by this specification, are listed in Table 1(a).

1.3 **MAXIMUM RATINGS**

The maximum ratings, applicable to the finished wires and cables specified herein, which shall not be exceeded at any time during use or storage in controlled space environment, are scheduled in Table 1(b).

1.4 **PARAMETER DERATING INFORMATION**

The derating information applicable to the finished wires and cables specified herein is as follows:

- The maximum current for each wire used in a bundle shall be:-

$$I_{Bmax} = I_{max} \times \frac{29 - n}{28} \quad (\text{for } 1 < n < 15)$$

$$I_{Bmax} = \frac{I_{max}}{2} \quad (\text{for } n > 15)$$

where n = number of wires in the bundle;

- The temperature derating information is shown in Figure 1 with maximum current I_{max} for a single wire.
- The derating factors contained herein indicate maximum stress values and do not preclude further derating.

1.5 **PHYSICAL CHARACTERISTICS**

The physical characteristics of the finished wires and cables specified herein are shown in Figures 2(a), 2(b) and 2(c) and their dimensions in Table 1(a).

1.6 **FUNCTIONAL DIAGRAM**

Not applicable.



ESCC Detail Specification
No. 3901/008

TABLE 1(a) - TYPE VARIANTS

VARIANT No.	SHIELDED		UN-SHIELDED	No. OF CORES	WIRE SIZE AWG	STRANDING No. OF STRANDS x DIAMETER (mm)	CONDUCTOR CHARACTERISTICS			SHIELD STRAND Ø (mm)	CORE MAX Ø (mm)	FINISHED WIRE OR CABLE CHARACTERISTICS	
	1 SHIELD	2 SHIELDS					MAX Ø (mm)	NOM SECT. (mm ²)	MAX OHMIC RESISTANCE (Ω/km)			MAX Ø (mm)	MAX WEIGHT (kg/km)
01			X	1	28	7 x 0.127	0.40	0.09	253	-	-	1.08	2.35
02			X	1	26	19 x 0.102	0.54	0.15	147	-	-	1.20	3.15
03			X	1	24	19 x 0.127	0.67	0.24	94	-	-	1.35	4.17
04			X	1	22	19 x 0.160	0.84	0.38	49.5	-	-	1.51	5.81
05			X	1	20	19 x 0.203	1.05	0.62	30.2	-	-	1.71	8.36
06			X	1	16	19 x 0.287	1.48	1.23	15.0	-	-	2.25	15.62
07			X	1	12	37 x 0.320	2.29	2.88	6.3	-	-	3.06	34.59
08			X	2	28	7 x 0.127	0.40	0.09	258	-	1.08	2.16	5.49
09			X	2	26	19 x 0.102	0.54	0.15	150	-	1.20	2.40	7.11
10			X	2	24	19 x 0.127	0.67	0.24	96	-	1.35	2.70	9.52
11			X	2	22	19 x 0.160	0.84	0.38	50.5	-	1.51	3.02	13.07
12			X	2	20	19 x 0.203	1.05	0.62	30.5	-	1.71	3.42	19.50
13			X	2	16	19 x 0.287	1.48	1.23	15.3	-	2.25	4.50	34.94
14			X	2	12	37 x 0.320	2.29	2.88	6.4	-	3.06	6.12	76.64
15			X	3	26	19 x 0.102	0.54	0.15	150	-	1.20	2.58	10.36
16			X	3	24	19 x 0.127	0.67	0.24	96	-	1.35	2.90	13.78
17			X	3	22	19 x 0.160	0.84	0.38	50.5	-	1.51	3.25	19.05
18			X	3	20	19 x 0.203	1.05	0.62	30.5	-	1.71	3.68	28.38
19			X	3	16	19 x 0.287	1.48	1.23	15.3	-	2.25	4.84	53.16
20			X	3	12	37 x 0.320	2.29	2.88	6.4	-	3.06	6.58	112.39
21			X	4	26	19 x 0.102	0.54	0.15	151	-	1.20	2.94	14.16
22			X	4	24	19 x 0.127	0.67	0.24	97	-	1.35	3.26	18.49
23			X	4	22	19 x 0.160	0.84	0.38	51	-	1.51	3.70	24.97
24			X	4	20	19 x 0.203	1.05	0.62	31.1	-	1.71	4.19	36.92
25			X	4	16	19 x 0.287	1.48	1.23	15.4	-	2.25	5.51	63.81



ESCC Detail Specification
No. 3901/008

TABLE 1(a) - TYPE VARIANTS (CONTINUED)

VARIANT No.	SHIELDED		UN-SHIELDED	No. OF CORES	WIRE SIZE AWG	STRANDING No. OF STRANDS x DIAMETER (mm)	CONDUCTOR CHARACTERISTICS				SHIELD STRAND Ø (mm)	CORE MAX Ø (mm)	FINISHED WIRE OR CABLE CHARACTERISTICS	
	1 SHIELD	2 SHIELDS					MAX Ø (mm)	NOM SECT. (mm ²)	MAX OHMIC RESISTANCE (Ω/km)	MAX Ø (mm)			MAX WEIGHT (kg/km)	
26			X	4	12	37 x 0.320	2.29	2.88	6.5	-	3.06	7.50	151.23	
27			X	5	26	19 x 0.102	0.54	0.15	152	-	1.20	3.24	19.11	
28			X	5	24	19 x 0.127	0.67	0.24	97.5	-	1.35	3.65	25.31	
29			X	5	22	19 x 0.160	0.84	0.38	51.3	-	1.51	4.08	34.85	
30			X	5	20	19 x 0.203	1.05	0.62	31.3	-	1.71	4.62	50.81	
31			X	7	26	19 x 0.102	0.54	0.15	153	-	1.20	3.60	24.05	
32			X	7	24	19 x 0.127	0.67	0.24	98	-	1.35	4.05	32.20	
33			X	7	22	19 x 0.160	0.84	0.38	51.5	-	1.51	4.53	45.95	
34			X	7	20	19 x 0.203	1.05	0.62	31.4	-	1.71	5.13	64.79	
35	X			1	28	7 x 0.127	0.40	0.09	253	0.102	-	1.92	8.32	
36	X			1	26	19 x 0.102	0.54	0.15	147	0.102	-	2.04	9.27	
37	X			1	24	19 x 0.127	0.67	0.24	94	0.102	-	2.19	11.12	
38	X			2	28	7 x 0.127	0.40	0.09	258	0.102	1.08	3.00	13.94	
39	X			2	26	19 x 0.102	0.54	0.15	150	0.102	1.20	3.24	16.25	
40	X			2	24	19 x 0.127	0.67	0.24	96	0.102	1.35	3.54	19.64	
41	X			2	22	19 x 0.160	0.84	0.38	50.5	0.102	1.51	3.86	29.18	
42	X			2	20	19 x 0.203	1.05	0.62	30.5	0.102	1.71	4.26	38.97	
43	X			2	16	19 x 0.287	1.48	1.23	15.3	0.127	2.25	5.54	57.14	
44	X			2	12	37 x 0.320	2.29	2.88	6.4	0.127	3.06	7.16	106.26	
45	X			3	26	19 x 0.102	0.54	0.15	150	0.102	1.20	3.42	19.91	
46	X			3	24	19 x 0.127	0.67	0.24	96	0.102	1.35	3.74	24.37	
47	X			3	22	19 x 0.160	0.84	0.38	50.5	0.102	1.51	4.09	36.34	
48	X			3	20	19 x 0.203	1.05	0.62	30.5	0.127	1.71	4.72	47.96	
49	X			3	16	19 x 0.287	1.48	1.23	15.3	0.127	2.25	5.88	78.94	
50	X			3	12	37 x 0.320	2.29	2.88	6.4	0.127	3.06	7.62	145.79	



ESCC Detail Specification
No. 3901/008

TABLE 1(a) - TYPE VARIANTS (CONTINUED)

VARIANT No.	SHIELDED		UN-SHIELDED	No. OF CORES	WIRE SIZE AWG	STRANDING No. OF STRANDS x DIAMETER (mm)	CONDUCTOR CHARACTERISTICS			SHIELD STRAND Ø (mm)	CORE MAX Ø (mm)	FINISHED WIRE OR CABLE CHARACTERISTICS	
	1 SHIELD	2 SHIELDS					MAX Ø (mm)	NOM SECT. (mm ²)	MAX OHMIC RESISTANCE (Ω/km)			MAX Ø (mm)	MAX WEIGHT (kg/km)
51	X			4	26	19x0.102	0.54	0.15	151	0.102	1.20	3.88	25.33
52	X			4	24	19x0.127	0.67	0.24	97	0.102	1.35	4.15	34.25
53	X			4	22	19x0.160	0.84	0.38	51	0.127	1.51	4.74	44.18
54	X			4	20	19x0.203	1.05	0.62	31.1	0.127	1.71	5.23	62.55
55	X			4	16	19x0.287	1.48	1.23	15.4	0.127	2.25	6.55	96.43
56	X			4	12	37x0.320	2.29	2.88	6.5	0.127	3.06	8.54	186.78
57	X			5	26	19x0.102	0.54	0.15	152	0.102	1.20	4.08	33.10
58	X			5	24	19x0.127	0.67	0.24	97.5	0.102	1.35	4.69	40.35
59	X			5	22	19x0.160	0.84	0.38	51.3	0.127	1.51	5.12	57.51
60	X			5	20	19x0.203	1.05	0.62	31.3	0.127	1.71	5.66	78.53
61	X			7	26	19x0.102	0.54	0.15	153	0.102	1.20	4.64	41.04
62	X			7	24	19x0.127	0.67	0.24	98	0.127	1.35	5.09	50.70
63	X			7	22	19x0.160	0.84	0.38	51.5	0.127	1.51	5.57	70.81
64	X			7	20	19x0.203	1.05	0.62	31.4	0.127	1.71	6.17	94.49
65		X		2	20	19x0.203	1.05	0.62	30.5	0.102/0.102	1.71	5.04	55.77
66		X		4	20	19x0.203	1.05	0.62	31.1	0.127/0.127	1.71	5.82	79.59

TABLE 1(b) - MAXIMUM RATINGS

No.	CHARACTERISTICS	SYMBOL	MAXIMUM RATINGS	UNIT	REMARKS
1	Voltage	V_p	600	V_{rms}	
2	Maximum Current (Note 1)	I_{max}	1.5 2.5 3.5 5.0 7.5 13.0 25.0	A	For AWG 28 26 24 22 20 16 12
3	Operating Temperature Range	T_{amb}	- 200 to + 200	°C	
4	Storage Temperature Range	T_{stg}	- 200 to + 200	°C	

NOTES

- The above specified current will generate a temperature rise of approximately 50°C above ambient temperature in a vacuum environment. Precautions shall be taken to prevent the total temperature of the wire (ambient plus rise) exceeding the continuous operating temperature of the wire.

FIGURE 1 - PARAMETER DERATING INFORMATION

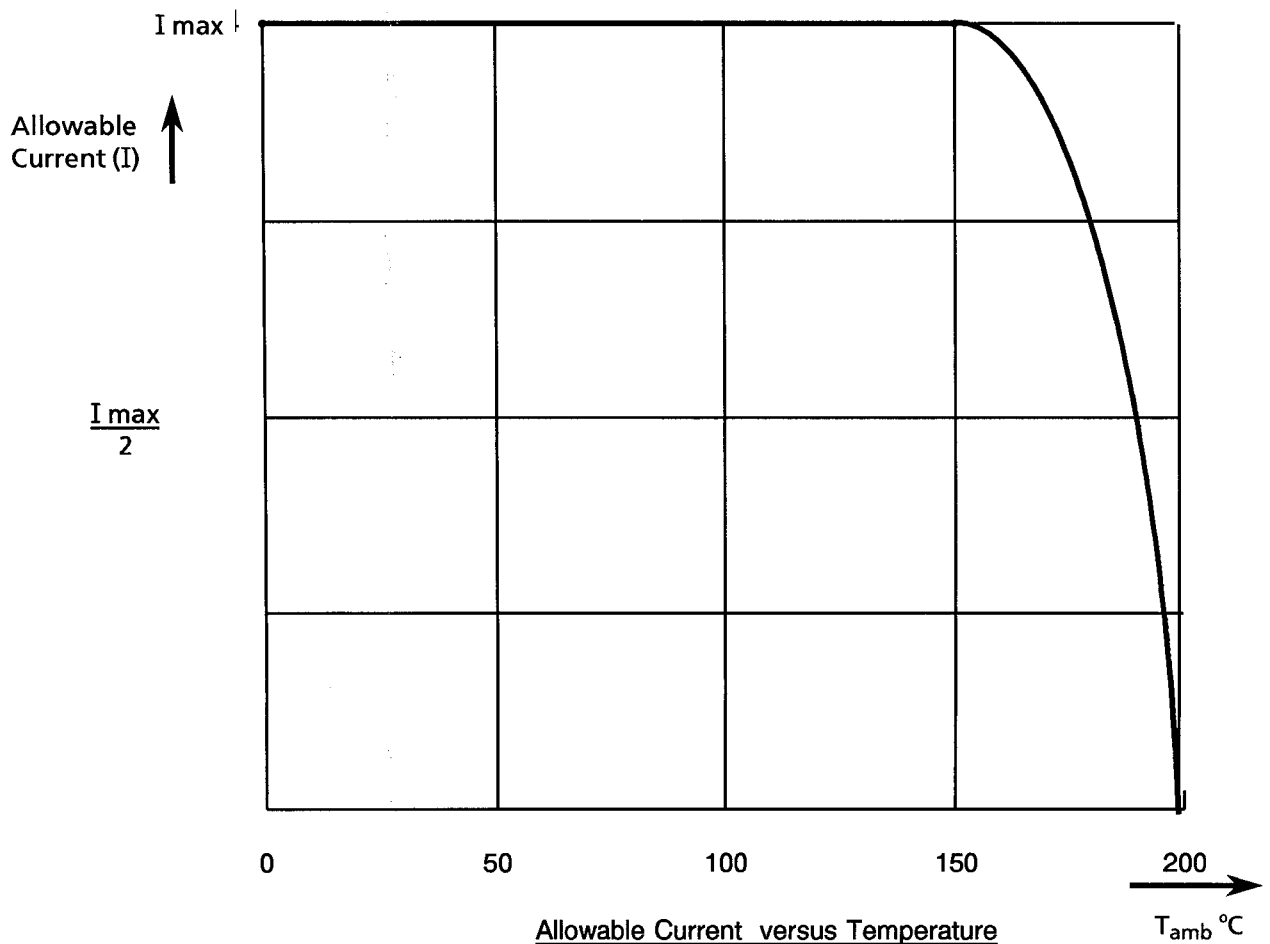

FIGURE 2 - PHYSICAL CHARACTERISTICS

Dimensions are given in Table 1(a)

FIGURE 2(a) - FINISHED WIRES

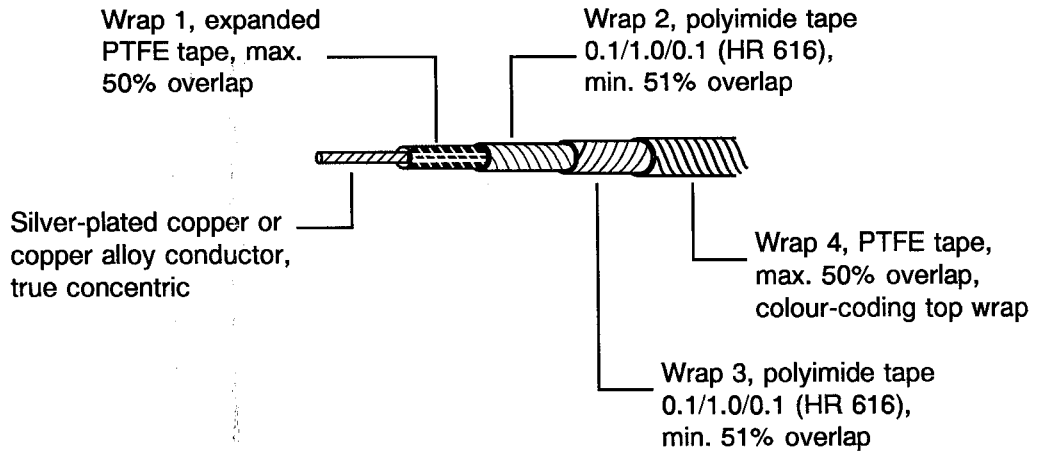

FIGURE 2(b) - SHIELDED AND JACKETED CABLES

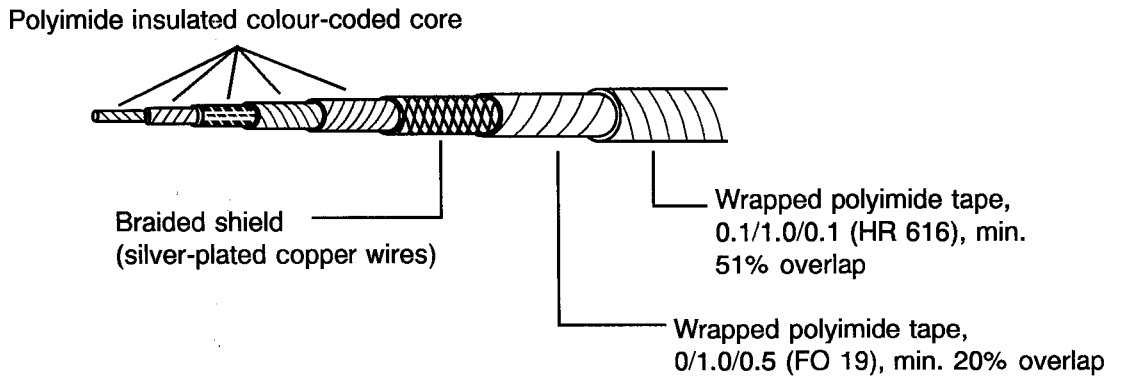
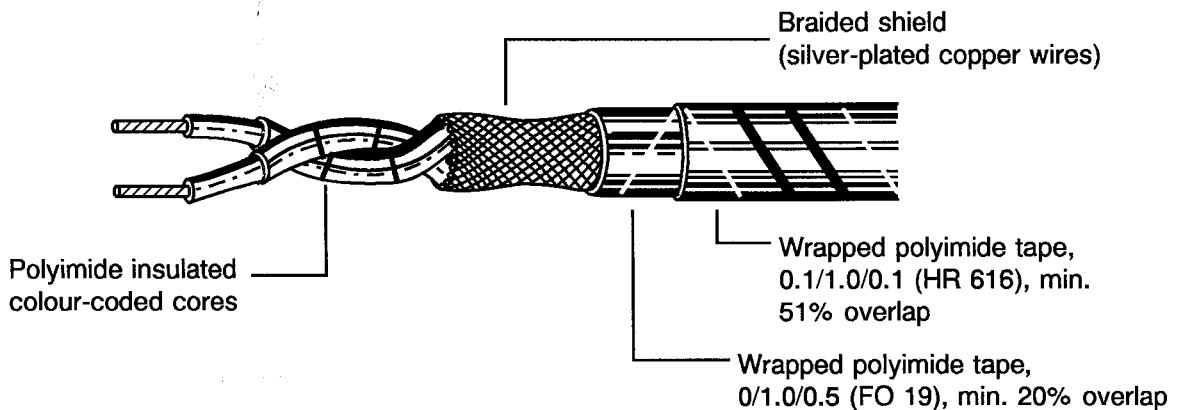

FIGURE 2(c) - SHIELDED AND JACKETED CABLES





2. APPLICABLE DOCUMENTS

The following documents form part of this specification and shall be read in conjunction with it:

- (a) ESCC Generic Specification No. 3901, "Wires and Cables, Electrical, 600V, Low Frequency".
- (b) MIL-STD-104, "Limits for Electrical Insulation Coloured".

3. TERMS, DEFINITIONS, ABBREVIATIONS, SYMBOLS AND UNITS

For the purpose of this specification, the terms, definitions, abbreviations, symbols and units specified in ESCC Basic Specification No. 21300 and ESCC Generic Specification No. 3901 shall apply.

4. REQUIREMENTS

4.1 GENERAL

The complete requirements for procurement of the finished wires and cables specified herein are stated in this specification and ESCC Generic Specification No. 3901. Deviations from the Generic Specification, applicable to this specification only, are listed in Para 4.2.

Deviations from the applicable Generic Specification and this Detail Specification, formally agreed with specific Manufacturers on the basis that the alternative requirements are equivalent to the ESCC requirements and do not affect the components' reliability, are listed in the Appendices attached to this specification.

4.2 DEVIATIONS FROM GENERIC SPECIFICATION

4.2.1 Deviations from Special In-process Controls

None.

4.2.2 Deviations from Final Production Tests (Chart II)

None.

4.2.3 Deviations from Burn-in and Electrical Measurements (Chart III)

Not applicable.

4.2.4 Deviations from Qualification Tests (Chart IV)

- (a) Para. 9.21, "Resistance to Fluids": To be modified as stated in Para. 4.8.11 of this specification.

4.2.5 Deviations from Lot Acceptance Tests (Chart V)

None.

4.3 MECHANICAL REQUIREMENTS

4.3.1 Dimension Check

The dimensions of the finished wires and cables specified herein shall be checked; they shall conform to those shown in Table 1(a), Figure 2 and Para 4.4 of this specification (see below for the list of parameters to be checked).

LIST OF PARAMETERS TO BE CHECKED

PARAMETER	TABLE 1(a)	FIGURE 2	PARA 4.4
<u>COMPOSITION</u>			
Number of conductors	X		
Gauge	X		
Shielding	X		
Jacket		X	
<u>CONDUCTOR</u>			
Nature			X
Outer diameter	X		
Number of strands	X		
Strand diameter	X		
Length of lay			X
Silver thickness			X
<u>INSULATION</u>			
Composition		X	X
Protective coating		X	X
Thickness			X
Overlapping			X
Outer diameter	X		
<u>SHIELDING</u>			
Number of strands	X		
Type of shielding			X
Strand diameter	X		
Nature		X	X
Silver thickness			X
Shielding lay			X
Shield coverage			X
<u>JACKET</u>			
Composition		X	X
Protective tape wraps		X	X
Thickness			X
Overlapping			X
Outer diameter	X		

4.3.2 Weight

The maximum weight of the finished wires and cables specified herein shall be as specified in Table 1(a).

	<p style="text-align: center;">ESCC Detail Specification No. 3901/008</p>		<p>PAGE 13 ISSUE 2</p>
---	---	--	----------------------------

4.4 MATERIALS AND FINISHES

The materials and finishes shall be as specified herein. Where a definite material is not specified, a material which will enable the wires and cables specified herein to meet the performance requirements of this specification shall be used. Acceptance or approval of any constituent material does not guarantee acceptance of the finished product.

4.4.1 Conductor

4.4.1.1 Material Characteristics

All strands used in the manufacture of the conductors shall be silver-coated, soft or annealed, oxygen-free high conductivity copper from AWG 12 to 22 inclusive and silver-coated, high strength copper alloy from AWG 24 to 28. On silver-coated strands, the thickness of silver shall be 2.0 microns minimum.

On all copper conductors, any strand shall show a 10% minimum elongation. On all high-strength copper alloy conductors, any strand shall show a 6% minimum elongation at break and a 350N/mm² minimum tensile strength.

The resistance of the conductors shall be determined at +20°C in accordance with Para. 9.5 of ESCC Generic Specification No. 3901, where the 'α' coefficient for copper alloy is 0.0035.

4.4.1.2 Stranding

The conductors shall be constructed of concentrically laid strands to produce a smooth and uniform conductor of circular cross-section and free from any high strands or other surface irregularities.

The length of lay of the external layer shall not be less than 8, nor more than 16, times the maximum conductor diameter specified in Table 1(a).

4.4.2 Insulation

4.4.2.1 Material

Any insulating material shall be virgin polyimide with only those additives that are necessary for processing and pigmentation.

4.4.2.2 Construction

The insulation shall have a uniform cross-section throughout the length of the cable and the conductor shall be evenly centred in the insulation.

The insulation shall consist of 2 wrapped layers of polyimide tapes as specified in Figure 2(a).

4.4.3 Shield

4.4.3.1 Material

Shield strands shall meet the requirements for silver-coated annealed copper as outlined in Para. 4.4.1.1 of this specification, but the thickness of silver shall be 2.5 microns minimum.



4.4.3.2 Construction

Shields shall be closely woven braid. The strand sizes for the shields shall be as specified in Table 1(a) of this specification.

The shield braid shall be a push-back type. The angle of the carriers of the braid with the axis of the cable shall not be less than 10, nor more than 40, degrees.

The shield braid shall be applied in such a manner as to provide a coverage of not less than 90%. The coverage factor 'K' is calculated by the following formula:

$$K = (2F - F^2) \times 100.$$

where:-

K = percent coverage.

$$F = \frac{N \cdot d \cdot P}{\sin a}$$

where:-

N = number of strands per carrier.

d = diameter of strands (mm).

P = picks per mm.

a = angle of shield with cable axis in degrees.

$$\tan a = \frac{2(D + 2d)P}{C}$$

where:-

D = effective diameter of cable under shield (mm).

C = number of carriers.

4.4.4 Jacket

All shielded cables shall be provided with jackets of wrapped polyimide tapes as specified in Figures 2(b) and 2(c). The wrapped tapes shall be heat-sealed. The side of the tape of the first layer above the shield, which is not coated with FEP resin, shall be facing the shield.

4.4.5 Construction of Multicore Cables

Multicore cables shall be constructed by twisting the required number and size of finished wires to form a uniform cable without high strands, bends or other irregularities. Finished wires of only one size shall be used for one cable. The cabling shall be with a left-hand lay and the lay length shall not be less than 12 times and not be more than 16 times the outside diameter of the unshielded unjacketed cable. The construction of shielded and jacketed cables is shown in Figure 2(c) (double-shielded cable not shown). Fillers shall not be used in the construction of multicore cables except for the 5-core cable, where the 5 wires shall be twisted around a round, uncoloured PTFE-filler. The diameter of the PTFE-filler for the 5-conductor cable shall be 0.7 times the diameter of the conductors used in the cable.

Double-shielded cables shall be constructed with a wrap of 0/0.5/0-tape in left-hand lay and at least 51% overlap over the first shield. This shall be followed by the second shield which shall also conform to the requirements of Para. 4.4.3 and a jacket as specified in Para. 4.4.4.

4.4.6 Colour-coding

4.4.6.1 Finished Wire Colour-coding

The colour of the finished wires shall be the natural colour of the top wrap on the insulation except when colouring is specifically required in the contract.

Colours

- Black (not preferred)
- Brown

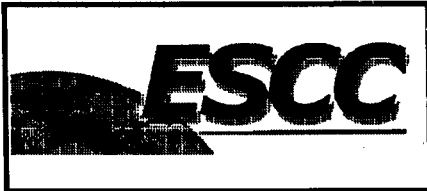

- Red
- Orange (not preferred)
- Yellow
- Green
- Blue
- Violet (not preferred)
- Grey
- White
- Natural

The colour of top wraps shall conform to the colour limits specified in MIL-STD-104, Class 1.

4.4.6.2 Multicore Cable Colour-coding

If the contract does not define any specific colour-coding, all individual cores in multicore cables shall have the natural colour. If colour-coding is desired, it is proposed that the individual cores in such cables shall be coloured according to the following scheme:-

Number of cores in cable	Colour of respective cores						
2	red	blue					
3	red	blue	yellow				
4	red	blue	yellow	green			
5	red	blue	yellow	green	brown		
6	red	blue	yellow	green	brown	grey	
7	red	blue	yellow	green	brown	grey	white

4.4.6.3 Jacket Colour

The colour of jackets shall normally be the natural colour of the polyimide tapes.

4.5 MARKING

4.5.1 General

The marking of all spools of finished wires and cables delivered to this specification shall be in accordance with the requirements of ESCC Basic Specification No. 21700. Each spool shall be marked in respect of:-

- (a) The ESCC Component Number.
- (b) Characteristics.
- (c) Traceability Information.
- (d) Additional Markings.

4.5.2 The ESCC Component Number

Each spool shall bear the ESCC Component Number which shall be constituted and marked as follows:-

390100802B

Detail Specification Number _____

Type Variant (see Table 1(a)) _____

Testing Level _____



4.5.3 Characteristics

The characteristics shall show the length(s) of finished wire or cable wound on each spool and shall be marked as follows:-

Length in metres (see Note) _____ 100m
Symbol for metres _____

NOTE

Whenever the length is less than 100 metres, insert a zero in the first block (example: 075m). If more than one length of finished wire or cable is wound on a spool, the characteristics of each length shall be marked as above.

4.5.4 Traceability Information

Each spool shall be marked in respect of traceability information in accordance with the requirements of ESCC Basic Specification No. 21700.

4.5.5 Additional Marking

Each spool shall bear the cable manufacturer's Quality Control Inspector's stamp and initials.

4.6 ELECTRICAL MEASUREMENTS

4.6.1 Electrical Measurements at Room Temperature

The parameters to be measured at room temperature are scheduled in Table 2. The measurements shall be performed at $T_{amb} = +22 \pm 3$ °C.

4.6.2 Electrical Measurements at High and Low Temperatures

Not applicable.

4.6.3 Circuits for Electrical Measurements

Not applicable.

4.7 BURN-IN TESTS

Not applicable.

4.8 ENVIRONMENTAL AND ENDURANCE TESTS

4.8.1 Mechanical Properties of Conductor

As detailed in Para. 4.4.1.1 of this Specification.

4.8.2 Accelerated Ageing

Ageing Temperature $+230 \pm 5$ °C.

The mandrel diameter and appropriate weight used for accelerated age testing of the finished wires is given in Table A.

TABLE A - MANDREL DIAMETERS AND LOADS FOR FINISHED WIRES

Wire Size (AWG)	Mandrel Diameter (mm)	Weight (kg)
28	6.0	0.25
26	6.0	0.25
24	6.0	0.25
22	6.0	0.4
20	6.0	0.4
16	10	0.5
12	20	1.0

4.8.3 Wrap Test at Ambient Temperature

The mandrel diameters and applied loads for wrap testing of finished wires are given in Table A. The mandrel diameters and applied loads for screened and jacketed cables are given in Table B.

TABLE B - MANDREL DIAMETERS AND LOADS FOR SHIELDED AND JACKETED CABLES

Cable Size (AWG)	Number of Cores	Mandrel Diameter (mm)	Load (kg)
28	1	8.0	0.25
26	1	10	0.25
24	1	12	0.25
28	2	12	0.5
26	2	15	0.5
24	2	15	0.5
22	2	20	0.8
20	2	20	0.8
16	2	25	1.0
12	2	30	1.0
26	3	15	0.75
24	3	15	0.75
22	3	20	1.2
20	3	20	1.2
16	3	30	1.5
12	3	40	1.5
26	4	15	1.0
24	4	20	1.0
22	4	20	1.5
20	4	25	1.5
16	4	30	1.5
12	4	40	1.5
26	5	20	1.5
24	5	20	1.5
22	5	25	2.0
20	5	30	2.0
26	7	20	1.5
24	7	20	1.5
22	7	25	2.0
20	7	30	2.0

4.8.4 Voltage Test

No particular conditions are applicable.

4.8.5 Shrinkage

The shrinkage temperature shall be $+230 \pm 5$ °C

4.8.6 Blocking

The blocking temperature shall be $+200 \pm 5$ °C.

4.8.7 Cold Bend Test

The mandrel diameters and loads shall be as specified in Table C.

TABLE C - MANDREL DIAMETERS AND LOADS FOR FINISHED WIRES OR CORES

Wire Size (AWG)	Mandrel Diameter (mm)	Weight (kg)
28	6.0	0.25
26	6.0	0.25
24	6.0	0.25
22	6.0	0.4
20	6.0	0.4
16	10	0.5
12	20	1.0

4.8.8 Cut-through Resistance

The mean load measured during the required tests shall not be less than the relevant value specified below:-

Wire Size (AWG)	28	26	24	22	20	16	12
Cut-through Load (kg)	12	15	17	21	26	43	66

4.8.9 Notch Resistance

The depth of notch shall be 0.04mm.

4.8.10 Flammability

No particular conditions are applicable.

4.8.11 Resistance to Fluids

Tests (e) and (f) shall not be performed.

4.8.12 Surface Resistance

No particular conditions are applicable.

4.8.13 Abrasion Resistance

The weight to be applied to the needle is specified below:-

Wire Size (AWG)	28	26	24	22	20	16	12
Scrape Abrasion Load (g)	500	650	750	800	900	1050	1200

4.8.14 Soldering

No particular conditions are applicable.

4.8.15 Solderability

No particular conditions are applicable.

4.8.16 Radiation Resistance

No particular conditions are applicable.

4.8.17 Overload Resistance

No particular conditions are applicable.

4.8.18 Long-term Ageing Test

The long-term ageing temperature shall be +200°C.

4.8.19 Anthony and Brown Test

No particular conditions are applicable.

TABLE 2 - ELECTRICAL MEASUREMENTS AT ROOM TEMPERATURE

No.	CHARACTERISTICS	SPEC. AND/OR TEST METHOD	TEST CONDITION	LIMITS	UNIT
1	Conductor Resistance	ESCC No. 3901, Section 9	Para 9.5	Table 1(a)	Ω/km
2	Spark Test	ESCC No. 3901, Section 9	Para 9.6	Insulation : 3 Jacket : 1.5	kV
3	Voltage Test	ESCC No. 3901, Section 9	Para 9.7	Para 9.7	kV
4	Insulation Resistance	ESCC No. 3901, Section 9	Para 9.8	Insulation : 750 Jacket : 30	MΩ.km
5	Surface Resistance	ESCC No. 3901, Section 9	Para 9.22	: 125	MΩ.mm