



Pages 1 to 13

TRANSISTORS, LOW POWER, NPN

BASED ON TYPE 2N3700

ESCC Detail Specification No. 5201/004

Issue 2	June 2007
---------	-----------



Document Custodian: European Space Agency - see <https://escies.org>

LEGAL DISCLAIMER AND COPYRIGHT

European Space Agency, Copyright © 2007. All rights reserved.

The European Space Agency disclaims any liability or responsibility, to any person or entity, with respect to any loss or damage caused, or alleged to be caused, directly or indirectly by the use and application of this ESCC publication.

This publication, without the prior permission of the European Space Agency and provided that it is not used for a commercial purpose, may be:

- copied in whole, in any medium, without alteration or modification.
- copied in part, in any medium, provided that the ESCC document identification, comprising the ESCC symbol, document number and document issue, is removed.

DOCUMENTATION CHANGE NOTICE

(Refer to <https://escies.org> for ESCC DCR content)

DCR No.	CHANGE DESCRIPTION
187, 264	Specification up issued to incorporate editorial and technical changes per DCRs.

TABLE OF CONTENTS

<u>1.</u>	<u>GENERAL</u>	<u>5</u>
1.1	Scope	5
1.2	Applicable Documents	5
1.3	Terms, Definitions, Abbreviations, Symbols and Units	5
1.4	The ESCC Component Number and Component Type Variants	5
1.4.1	The ESCC Component Number	5
1.4.2	Component Type Variants	5
1.5	Maximum Ratings	5
1.6	Physical Dimensions and Terminal Identification	6
1.6.1	Metal Can Package (TO-18) - 3 lead	6
1.6.2	Chip Carrier Package (CCP) - 3 terminal	7
1.7	Functional Diagram	8
1.8	Materials and Finishes	8
<u>2.</u>	<u>REQUIREMENTS</u>	<u>9</u>
2.1	General	9
2.1.1	Deviations from the Generic Specification	9
2.1.1.1	Deviation from Screening Tests - Chart F3	9
2.2	Marking	9
2.3	Terminal Strength	9
2.4	Electrical Measurements at Room, High and Low Temperatures	9
2.4.1	Room Temperature Electrical Measurements	9
2.4.2	High and Low Temperatures Electrical Measurements	11
2.5	Parameter Drift Values	11
2.6	Intermediate and End-Point Electrical Measurements	11
2.7	Power Burn-in Conditions	12
2.8	Operating Life Conditions	12
APPENDIX 'A'		13

1. GENERAL

1.1 SCOPE

This specification details the ratings, physical and electrical characteristics and test and inspection data for the component type variants and/or the range of components specified below. It supplements the requirements of, and shall be read in conjunction with, the ESCC Generic Specification listed under Applicable Documents.

1.2 APPLICABLE DOCUMENTS

The following documents form part of this specification and shall be read in conjunction with it:

- (a) ESCC Generic Specification No. 5000
- (b) MIL-STD-750, Test Methods and Procedures for Semiconductor Devices

1.3 TERMS, DEFINITIONS, ABBREVIATIONS, SYMBOLS AND UNITS

For the purpose of this specification, the terms, definitions, abbreviations, symbols and units specified in ESCC Basic Specification No. 21300 shall apply.

1.4 THE ESCC COMPONENT NUMBER AND COMPONENT TYPE VARIANTS

1.4.1 The ESCC Component Number

The ESCC Component Number shall be constituted as follows:

Example: 520100401

- Detail Specification Reference: 5201004
- Component Type Variant Number: 01 (as required)

1.4.2 Component Type Variants

The component type variants applicable to this specification are as follows:

Variant Number	Based on Type	Case	Lead/Terminal Material and/or Finish	Weight max g
01	2N3700	TO-18	D2	0.4
02	2N3700	TO-18	D3 or D4	0.4
04	2N3700	CCP	2	0.06
05	2N3700	CCP	4	0.06

The lead/terminal material and/or finish shall be in accordance with the requirements of ESCC Basic Specification No. 23500.

1.5 MAXIMUM RATINGS

The maximum ratings shall not be exceeded at any time during use or storage.

Maximum ratings shall only be exceeded during testing to the extent specified in this specification and when stipulated in Test Methods and Procedures of the ESCC Generic Specification.

Characteristics	Symbols	Maximum Ratings	Unit	Remarks
Collector-Base Voltage	V_{CBO}	140	V	Over entire operating temperature range
Collector-Emitter Voltage	V_{CEO}	80	V	
Emitter-Base Voltage	V_{EBO}	7	V	
Collector Current	I_C	1	A	Continuous
Power Dissipation For TO-18 and CCP For CCP For TO-18	P_{tot1}	0.5	W	At $T_{amb} \leq +25^\circ C$ Note 1
	P_{tot2}	0.76 (Note 2)	W	
	P_{tot3}	1.8	W	At $T_{case} \leq +25^\circ C$ Note 1
Operating Temperature Range	T_{op}	-65 to +200	$^\circ C$	Note 3
Storage Temperature Range	T_{stg}	-65 to + 200	$^\circ C$	Note 3
Soldering Temperature For TO-18 For CCP	T_{sol}	+260	$^\circ C$	Note 4
		+245		Note 5

NOTES:

1. For T_{amb} or $T_{case} > +25^\circ C$, derate linearly to 0W at $+200^\circ C$.
2. When mounted on a 15 x 15 x 0.6mm ceramic substrate.
3. For Variants with tin-lead plating or hot solder dip lead finish all testing performed at $T_{amb} > +125^\circ C$ shall be carried out in a 100% inert atmosphere.
4. Duration 10 seconds maximum at a distance of not less than 1.5mm from the device body and the same lead shall not be resoldered until 3 minutes have elapsed.
5. Duration 5 seconds maximum and the same terminal shall not be resoldered until 3 minutes have elapsed.

1.6 PHYSICAL DIMENSIONS AND TERMINAL IDENTIFICATION

1.6.1 Metal Can Package (TO-18) - 3 lead

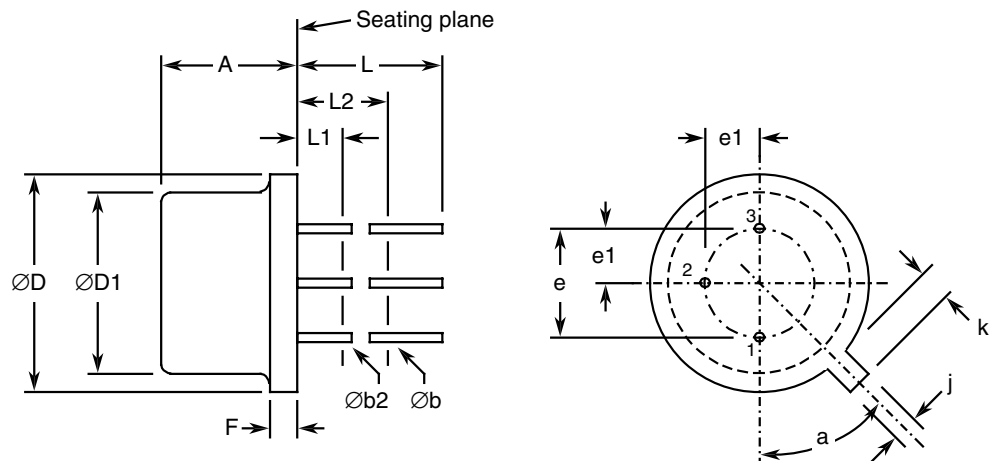

Symbols	Dimensions mm		Notes
	Min	Max	
A	4.32	5.33	
Øb	0.406	0.533	2, 3
Øb2	0.406	0.483	2, 3
ØD	5.31	5.84	
ØD1	4.52	4.95	
e	2.54 BSC		4
e1	1.27 BSC		4
F	-	0.762	
j	0.914	1.17	
k	0.711	1.22	5
L	12.7	-	2
L1	-	1.27	3
L2	6.35	-	3
a	45° BSC		1, 4, 6

NOTES:

1. Terminal identification is specified by reference to the tab position where lead 1 = emitter, lead 2 = base, lead 3 = collector.
2. Applies to all leads.
3. Øb2 applies between L1 and L2. Øb applies between L2 and 12.7mm from the seating plane. Diameter is uncontrolled within L1 and beyond 12.7mm from the seating plane.
4. Leads having maximum diameter 0.483mm measured in the gauging plane 1.37(+0.025,-0)mm below the seating plane of the device shall be within 0.178mm of their true position relative to a maximum-width-tab.
5. Measured from the maximum diameter of the actual device.
6. Tab centreline.

1.6.2 Chip Carrier Package (CCP) - 3 terminal

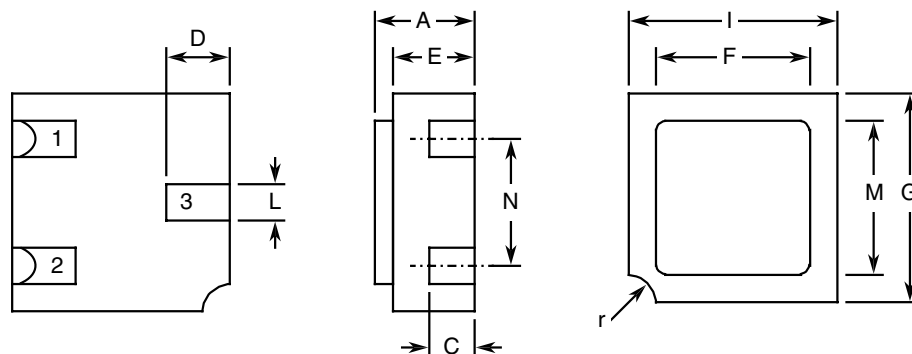

Symbols	Dimensions mm		Notes
	Min	Max	
A	1.15	1.5	
C	0.45	0.56	2
D	0.6	0.91	2
E	0.91	1.12	
F	1.9	2.15	
G	2.9	3.25	
I	2.4	2.85	
L	0.4	0.6	2
M	2.4	2.65	
N	1.8	2	
r	0.3 TYPICAL		1

NOTES:

- Terminal identification is specified by reference to the corner notch position where terminal 1 = emitter, terminal 2 = base, terminal 3 = collector.
- Applies to all terminals.

1.7 FUNCTIONAL DIAGRAM

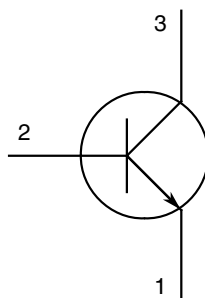

- Emitter.
- Base.
- Collector.

NOTES:

- For TO-18, the collector is internally connected to the case.
- For CCP, the lid is not connected to any terminal.

1.8 MATERIALS AND FINISHES

Materials and finishes shall be as follows:

- Case
 - For the metal can package the case shall be hermetically sealed and have a metal body with hard glass seals.
 - For the chip carrier package the case shall be hermetically sealed and have a ceramic body with a Kovar lid.
- Leads/Terminals

As specified in Component Type Variants.

2. REQUIREMENTS

2.1 GENERAL

The complete requirements for procurement of the components specified herein are as stated in this specification and the ESCC Generic Specification. Permitted deviations from the Generic Specification, applicable to this specification only, are listed below.
 Permitted deviations from the Generic Specification and this Detail Specification, formally agreed with specific Manufacturers on the basis that the alternative requirements are equivalent to the ESCC requirement and do not affect the component's reliability, are listed in the appendices attached to this specification.

2.1.1 Deviations from the Generic Specification

2.1.1.1 Deviation from Screening Tests - Chart F3

High Temperature Reverse Bias Burn-in and the subsequent Final Measurements for HTRB shall be omitted.

2.2 MARKING

The marking shall be in accordance with the requirements of ESCC Basic Specification No. 21700 and as follows.

The information to be marked on the component shall be:

- (a) The ESCC qualified components symbol (for ESCC qualified components only).
- (b) The ESCC Component Number.
- (c) Traceability information.

2.3 TERMINAL STRENGTH

The test conditions for terminal strength, tested as specified in the ESCC Generic Specification, shall be as follows:

For TO-18, Test Condition: E, lead fatigue.

2.4 ELECTRICAL MEASUREMENTS AT ROOM, HIGH AND LOW TEMPERATURES

Electrical measurements shall be performed at room, high and low temperatures.

2.4.1 Room Temperature Electrical Measurements

The measurements shall be performed at $T_{amb}=+22 \pm 3^{\circ}C$.

Characteristics	Symbols	MIL-STD-750 Test Method	Test Conditions	Limits		Units
				Min	Max	
Collector-Emitter Breakdown Voltage	$V_{(BR)CEO}$	3011	$I_C = 30mA$, Bias Condition D Note 1	80	-	V

Characteristics	Symbols	MIL-STD-750 Test Method	Test Conditions	Limits		Units
				Min	Max	
Collector-Base Breakdown Voltage	$V_{(BR)CBO}$	3001	$I_C = 100\mu A$ Bias Condition D	140	-	V
Emitter-Base Breakdown Voltage	$V_{(BR)EBO}$	3026	$I_E = 100\mu A$, Bias Condition D	7	-	V
Collector-Base Cut-off Current	I_{CBO}	3036	$V_{CB} = 90V$, Bias Condition D	-	10	nA
Emitter-Base Cut-off Current	I_{EBO}	3061	$V_{EB} = 5V$, Bias Condition D	-	10	nA
Collector-Emitter Saturation Voltage	$V_{CE(sat)1}$	3071	$I_C=150mA$ $I_B=15mA$ Note 1	-	200	mV
	$V_{CE(sat)2}$	3071	$I_C=150mA$ $I_B=50mA$ Note 1	-	500	mV
Base-Emitter Saturation Voltage	$V_{BE(sat)}$	3066	$I_C=150mA$, $I_B=15mA$ Test Condition A Note 1	-	1.1	V
Forward-Current Transfer Ratio	h_{FE1}	3076	$V_{CE}=10V$; $I_C = 10mA$ Note 1	90	-	-
	h_{FE2}	3076	$V_{CE}=10V$; $I_C = 150mA$ Note 1	100	300	-
	h_{FE3}	3076	$V_{CE}=10V$; $I_C = 500mA$ Note 1	50	-	-
Input Capacitance	C_{ibo}	3240	$V_{EB}=500mV$ $I_C=0A$ $f=1MHz$ Note 2	-	60	pF
Output Capacitance	C_{obo}	3236	$V_{CB}=10V$, $I_E=0A$ $f=1MHz$ Note 2	-	12	pF
Magnitude of Small-Signal Short-Circuit Forward-Current Transfer Ratio	$ h_{fe} $	3306	$V_{CE}=10V$, $I_C=50mA$ $f=20MHz$ Note 2	5	-	-

NOTES:

1. Pulse measurement: Pulse Width $\leq 300\mu s$, Duty Cycle $\leq 2\%$
2. For AC characteristics read and record measurements shall be performed on a sample of 32 components with 0 failures allowed. Alternatively a 100% inspection may be performed.

2.4.2 High and Low Temperatures Electrical Measurements

Characteristics	Symbols	MIL-STD-750 Test Method	Test Conditions Note 1	Limits		Units
				Min	Max	
Collector-Base Cut-off Current	I_{CBO}	3036	$T_{amb}=+150(+0-5)^{\circ}C$ $V_{CB}=90V$, Bias Condition D	-	10	μA
Forward-Current Transfer Ratio 2	h_{FE2}	3076	$T_{amb}=-55(+5-0)^{\circ}C$ $V_{CE}=10V$ $I_C=150mA$ Note 2	40	-	-

NOTES:

1. Read and record measurements shall be performed on a sample of 5 components with 0 failures allowed. Alternatively a 100% inspection may be performed.
2. Pulse measurement: Pulse Width $\leq 300\mu s$, Duty Cycle $\leq 2\%$

2.5 PARAMETER DRIFT VALUES

Unless otherwise specified, the measurements shall be performed at $T_{amb}=+22 \pm 3^{\circ}C$. The test methods and test conditions shall be as per the corresponding test defined in Room Temperature Electrical Measurements. The drift values (Δ) shall not be exceeded for each characteristic specified. The corresponding absolute limit values for each characteristic shall not be exceeded.

Characteristics	Symbols	Limits			Units
		Drift Value Δ	Absolute		
			Min	Max	
Collector-Base Cut-off Current	I_{CBO}	± 1 or (1) $\pm 100\%$	-	10	nA
Collector-Emitter Saturation Voltage 1	$V_{CE(sat)1}$	± 20 or (1) $\pm 15\%$	-	200	mV
Forward-Current Transfer Ratio 2	h_{FE2}	$\pm 15\%$	100	300	-

NOTES:

1. Whichever is the greater referred to the initial value.

2.6 INTERMEDIATE AND END-POINT ELECTRICAL MEASUREMENTS

Unless otherwise specified, the measurements shall be performed at $T_{amb}=+22 \pm 3^{\circ}C$. The test methods and test conditions shall be as per the corresponding test defined in Room Temperature Electrical Measurements. The limit values for each characteristic shall not be exceeded.

Characteristics	Symbols	Limits		Units
		Min	Max	
Collector-Base Cut-off Current	I_{CBO}	-	10	nA
Collector-Emitter Saturation Voltage 1	$V_{CE(sat)1}$	-	200	mV
Forward-Current Transfer Ratio 2	h_{FE2}	100	300	-

2.7 POWER BURN-IN CONDITIONS

Characteristics	Symbols	Conditions	Units
Ambient Temperature	T_{amb}	+20 to +50	°C
Power Dissipation	P_{tot}	As per Maximum Ratings P_{tot} derated at the chosen T_{amb}	W
Collector-Base Voltage	V_{CB}	50	V

2.8 OPERATING LIFE CONDITIONS

The conditions shall be as specified for Power Burn-in.

APPENDIX 'A'

AGREED DEVIATIONS FOR STMICROELECTRONICS (F)

ITEMS AFFECTED	DESCRIPTION OF DEVIATIONS
<p>Deviations from Production Control-Chart F2</p>	<p>Special In-process Control Internal Visual Inspection. For CCP packages the criteria specified for voids in the fillet and minimum die mounting material around the visible die perimeter for die mounting defects may be omitted providing that a radiographic inspection to verify the die-attach process is performed on a sample basis in accordance with STMicroelectronics procedure 0076637.</p>
<p>Deviations from Room Temperature Electrical Measurements</p>	<p>All AC characteristics (Room Temperature Electrical Measurement Note 2) may be considered guaranteed but not tested if successful pilot lot testing has been performed on the wafer lot which includes AC characteristic measurements per the Detail Specification.</p> <p>A summary of the pilot lot testing shall be provided if required by the Purchase Order.</p>
<p>Deviations from High and Low Temperatures Electrical Measurements</p>	<p>All characteristics specified may be considered guaranteed but not tested if successful pilot lot testing has been performed on the wafer lot which includes characteristic measurements at high and low temperatures per the Detail Specification.</p> <p>A summary of the pilot lot testing shall be provided if required by the Purchase Order.</p>