



**TRANSISTORS, HIGH POWER, PNP,
BASED ON TYPE BUX78
ESCC Detail Specification No. 5204/006**

**ISSUE 1
October 2002**



	ESCC Detail Specification		PAGE ii ISSUE 1
--	---------------------------	--	--------------------

LEGAL DISCLAIMER AND COPYRIGHT

European Space Agency, Copyright © 2002. All rights reserved.

The European Space Agency disclaims any liability or responsibility, to any person or entity, with respect to any loss or damage caused, or alleged to be caused, directly or indirectly by the use and application of this ESCC publication.

This publication, without the prior permission of the European Space Agency and provided that it is not used for a commercial purpose, may be:

- copied in whole in any medium without alteration or modification.
- copied in part, in any medium, provided that the ESCC document identification, comprising the ESCC symbol, document number and document issue, is removed.



**europaean space agency
agence spatiale européenne**

Pages 1 to 19

TRANSISTORS, HIGH POWER, PNP,

BASED ON TYPE BUX78

ESA/SCC Detail Specification No. 5204/006

SCC

**space components
coordination group**

Issue/Rev.	Date	Approved by	
		SCCG Chairman	ESA Director General or his Deputy
Issue 4	January 1998	<i>Sam Mills</i>	<i>[Signature]</i>



DOCUMENTATION CHANGE NOTICE

Rev. Letter	Rev. Date	Reference	CHANGE Item	Approved DCR No.
		This Issue supersedes Issue 3 and incorporates all modifications defined in Revisions 'A', 'B' and 'C' to Issue 3 and the changes agreed in the following DCRs:-		
		Cover Page		None
		DCN		None
		Para. 1.2	: Existing text deleted and new text added	221403
		Para. 2	: Item (c) deleted	221403
		Table 1(a)	: Format amended and Variants 06 to 07 added	221403
		Table 1(b)	: Nos. 1 to 3, "Breakdown" deleted from Characteristics and "BR" from Symbol	221403
			: Nos. 4 and 5, "(Continuous)" added to Characteristics	221403
			: No. 6, "Variants 01 to 05" added to existing entry and "Variants 06 to 07" entry added.	221403
			: No. 7, "T _{case} " added to Remarks	221403
			: No. 9, Existing Remarks deleted and "Note 2" added	221403
			: No. 10, New No. 10 added	221403
			: Notes, New Note 2 added	221403
		Figure 1	: First Figure renumbered to "1(a)" and subtitle and graph amended	221403
			: Second Figure renumbered to "1(b)" and subtitle and graph amended	221403
			: Note added	221403
		Figure 2	: Subtitle added to existing Figure	221403
			: New Figure 2(b) added	221403
		Figure 3	: Notes amended	221403
		Para. 4.3.2	: Existing text deleted and new text added	221403
		Para. 4.4.1	: Existing text amended and new text added	221403
		Para. 4.4.2	: Existing text modified and new text added	221403
		Para. 4.5.1	: Existing text deleted and new text added	221403
		Para. 4.5.3	: Entry for "Type Variant" amended	221403
		Para. 4.5.5	: Deleted in toto	221403
		Para. 4.6.1	: Second sentence amended	221403
		Para. 4.7.2	: New Para. 4.7.2 added	221403
			: Existing Para. 4.7.2 renumbered to "4.7.3" and title and text amended	221403
		Para. 4.7.3	: Renumbered as "4.7.5" and title and text amended	221403
		Para. 4.7.4	: New Para. 4.7.4 added	221403
		Para. 4.7.6	: New Para. 4.7.6 added	221403
		Table 2 d.c.	: No. 12 deleted	221403
		Table 2 a.c.	: Items renumbered "12" to "14" respectively	221403
		Table 3	: No. 16 renumbered as "15"	221403
		Table 5	: First Table renumbered to "5(a)" and title amended	221403
			: No. 1, Characteristics and Symbol amended	221403
			: No. 4 added	221403
			: Second Table renumbered to "5(b)" and title amended	221403
			: No. 2, Variants 01 to 05 added to existing entry and "Variants 06 to 07" added	221403
			: No. 3, Characteristic and Symbol amended	221403
		Figure 5	: First Figure renumbered to "5(a)" and title amended	221403
			: Second Figure numbered as "5(b)" and title amended	221403
		Para. 4.8.1	: Text added at the beginning of the second sentence	221403
		Para. 4.8.2	: Second sentence added	221403
		Para. 4.8.3	: In the second sentence, text amended	221403
		Para. 4.8.4	: Text amended	221403

**TABLE OF CONTENTS**

	<u>Page</u>
1. <u>GENERAL</u>	5
1.1 Scope	5
1.2 Component Type Variants	5
1.3 Maximum Ratings	5
1.4 Parameter Derating Information	5
1.5 Physical Dimensions	5
1.6 Functional Diagram	5
1.7 High Temperature Test Precautions	5
2. <u>APPLICABLE DOCUMENTS</u>	5
3. <u>TERMS, DEFINITIONS, ABBREVIATIONS, SYMBOLS AND UNITS</u>	5
4. <u>REQUIREMENTS</u>	10
4.1 General	10
4.2 Deviations from Generic Specification	10
4.2.1 Deviations from Special In-process Controls	10
4.2.2 Deviations from Final Production Tests	10
4.2.3 Deviations from Burn-in and Electrical Measurements	10
4.2.4 Deviations from Qualification Tests	10
4.2.5 Deviations from Lot Acceptance Tests	10
4.3 Mechanical Requirements	10
4.3.1 Dimension Check	10
4.3.2 Weight	10
4.3.3 Terminal Strength	10
4.4 Materials and Finishes	11
4.4.1 Case	11
4.4.2 Lead Material and Finish	11
4.5 Marking	11
4.5.1 General	11
4.5.2 Lead Identification	11
4.5.3 The SCC Component Number	11
4.5.4 Traceability Information	12
4.6 Electrical Measurements	12
4.6.1 Electrical Measurements at Room Temperature	12
4.6.2 Electrical Measurements at High and Low Temperatures	12
4.6.3 Circuits for Electrical Measurements	12
4.7 Burn-in Tests	12
4.7.1 Parameter Drift Values	12
4.7.2 Conditions for High Temperature Reverse Bias Burn-in	12
4.7.3 Conditions for Power Burn-in	12
4.7.4 Electrical Circuit for High Temperature Reverse Bias Burn-in	12
4.7.5 Electrical Circuit for Power Burn-in	12
4.7.6 Verification of Safe Operating Area	12
4.8 Environmental and Endurance Tests	18
4.8.1 Electrical Measurements on Completion of Environmental Tests	18
4.8.2 Electrical Measurements at Intermediate Points and on Completion of Endurance Tests	18
4.8.3 Conditions for Operating Life Tests	18
4.8.4 Electrical Circuit for Operating Life Tests	18
4.8.5 Conditions for High Temperature Storage Test	18



TABLES

1(a)	Type Variants	6
1(b)	Maximum Ratings	6
2	Electrical Measurements at Room Temperature - d.c. Parameters	13
	Electrical Measurements at Room Temperature - a.c. Parameters	14
3	Electrical Measurements at High and Low Temperatures	14
4	Parameter Drift Values	16
5(a)	Conditions for High Temperature Reverse Bias Burn-in	16
5(b)	Conditions for Power Burn-in and Operating Life Tests	16
6	Electrical Measurements at Intermediate Points and on Completion of Endurance Testing	19

FIGURES

1	Parameter Derating Information	7
2	Physical Dimensions	8
3	Functional Diagram	9
4	Circuits for Electrical Measurements	15
5(a)	Electrical Circuit for High Temperature Reverse Bias Burn-in	17
5(b)	Electrical Circuit for Power Burn-in and Operating Life Tests	17

APPENDICES (Applicable to specific Manufacturers only)

None.

**1. GENERAL****1.1 SCOPE**

This specification details the ratings, physical and electrical characteristics, test and inspection data for a Transistor, High Power, PNP, based on Type BUX78.

It shall be read in conjunction with ESA/SCC Generic Specification No. 5000, the requirements of which are supplemented herein.

1.2 COMPONENT TYPE VARIANTS

Variants of the basic transistors specified herein, which also covered by this specification, are given in Table 1(a).

1.3 MAXIMUM RATINGS

The maximum ratings, which shall not be exceeded at any time during use or storage, applicable to the transistors specified herein, are scheduled in Table 1(b).

1.4 PARAMETER DERATING INFORMATION

The derating information applicable to the transistors specified herein is shown in Figure 1.

1.5 PHYSICAL DIMENSIONS

The physical dimensions of the transistors specified herein are shown in Figure 2.

1.6 FUNCTIONAL DIAGRAM

The functional diagram, showing lead identification, of the transistors specified herein, is shown in Figure 3.

1.7 HIGH TEMPERATURE TEST PRECAUTIONS

For tin-lead plated or solder-dipped lead finish, all tests to be performed at a temperature that exceeds +125°C shall be carried out in 100% inert atmosphere.

2. APPLICABLE DOCUMENTS

The following documents form part of this specification and shall be read in conjunction with it:-

- (a) ESA/SCC Generic Specification No. 5000 for Discrete Semiconductors.
- (b) MIL-STD-750, Test Methods and Procedures for Semiconductor Devices.

3. TERMS, DEFINITIONS, ABBREVIATIONS, SYMBOLS AND UNITS

For the purpose of this specification, the terms, definitions, abbreviations, symbols and units specified in ESA/SCC Basic Specification No. 21300 shall apply.



TABLE 1(a) - TYPE VARIANTS

VARIANT	BASED ON TYPE	CASE	FIGURE	LEAD MATERIAL AND FINISH
01	BUX78	TO66	2(a)	D2
02	BUX78	TO66	2(a)	D3 or D4
03	BUX78	TO66	2(a)	F9
04	BUX78	TO66	2(a)	F2
05	BUX78	TO66	2(a)	F3 or F4
06	BUX78	TO257	2(b)	H2
07	BUX78	TO257	2(b)	H4

TABLE 1(b) - MAXIMUM RATINGS

No.	CHARACTERISTICS	SYMBOL	MAXIMUM RATINGS	UNIT	REMARKS
1	Collector-Base Voltage	V_{CBO}	- 100	V	
2	Collector-Emitter Voltage	V_{CEO}	- 80	V	
3	Emitter-Base Voltage	V_{EBO}	- 6.0	V	
4	Collector Current (Continuous)	I_C	- 5.0	A	
5	Base Current (Continuous)	I_B	- 0.8	A	
6	Power Dissipation Variants 01 to 05 Variants 06 to 07	P_{tot}	40 35	W	$T_{case} = +25^{\circ}C$ Note 1
7	Operating Temperature Range	T_{op}	- 65 to + 200	$^{\circ}C$	T_{case}
8	Storage Temperature Range	T_{stg}	- 65 to + 200	$^{\circ}C$	
9	Soldering Temperature	T_{sol}	+ 260	$^{\circ}C$	Note 2
10	Thermal Resistance Variants 01 to 05 Variants 06 to 07	$R_{TH(J-C)}$	4.4 5.0	$^{\circ}C/W$	

NOTES

- For derating at $T_{case} > +25^{\circ}C$, see Figure 1(a).
- Duration 10 seconds maximum at a distance of not less than 1.5mm from the device body and the same lead shall not be resoldered until 3 minutes have elapsed.



FIGURE 1 - PARAMETER DERATING INFORMATION

FIGURE 1(a) - POWER DISSIPATION VERSUS TEMPERATURE

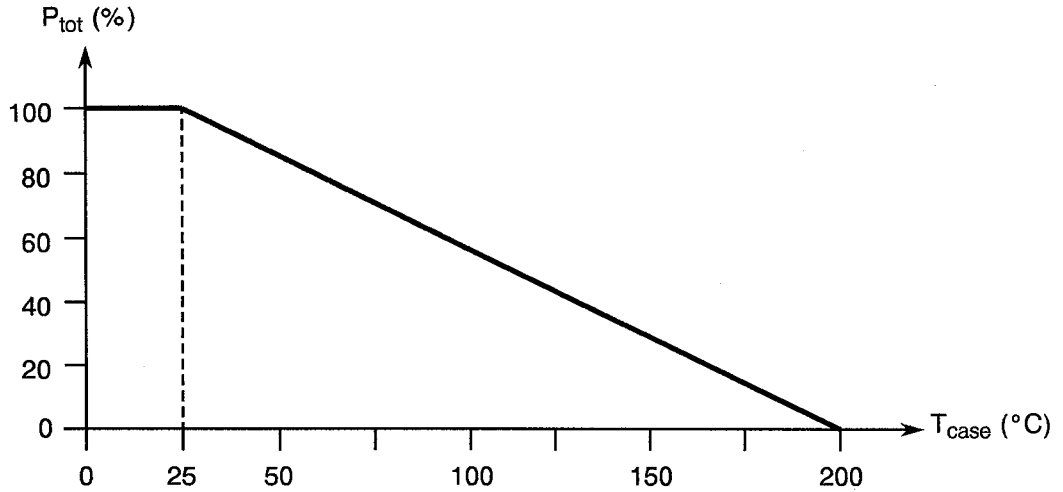
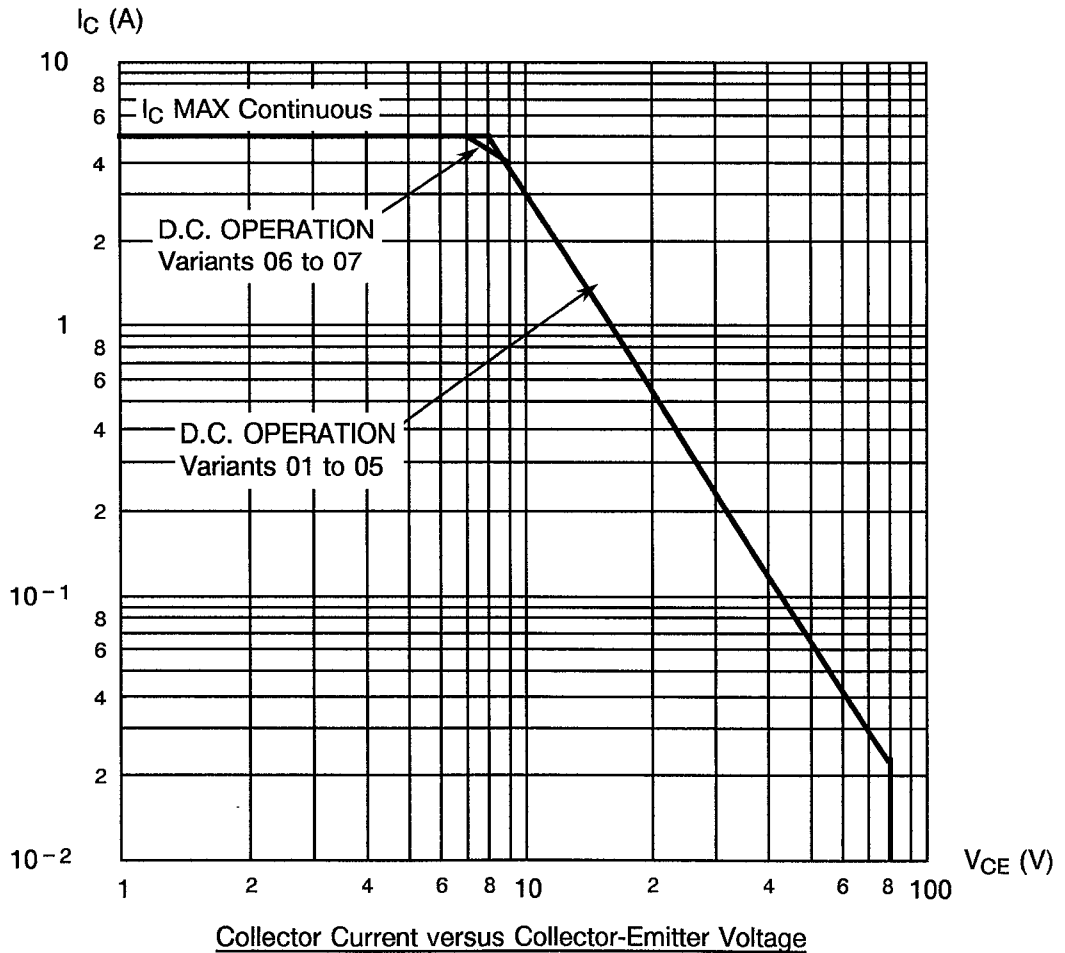


FIGURE 1(b) - FORWARD BIAS SAFE OPERATING AREA (MAXIMUM CONTINUOUS D.C.)



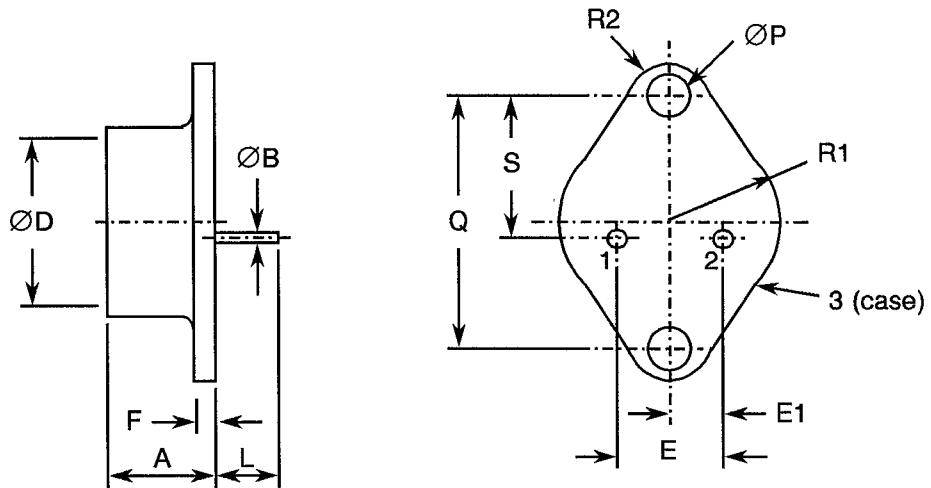
NOTES

- 1. See Para. 4.7.6.



FIGURE 2 - PHYSICAL DIMENSIONS

FIGURE 2(a) - VARIANTS 01 TO 05



SYMBOL	MILLIMETRES	
	MIN.	MAX.
A	6.35	8.64
$\varnothing B$	0.71	0.86
$\varnothing D$	11.94	12.70
E	4.83	5.34
E1	2.36	2.72
F	1.27	1.91
L	9.14	-
$\varnothing P$	3.61	3.86
Q	24.33	24.43
R1	-	8.89
R2	3.61	3.86
S	14.48	14.99



FIGURE 2 - PHYSICAL DIMENSIONS (CONT.)

FIGURE 2(b) - VARIANTS 06 to 07

SYMBOL	MILLIMETRES	
	MIN.	MAX.
A	10.41	10.67
B	10.41	10.67
C	16.51	16.76
D	4.7	5.33
E	0.89	1.14
ØF	3.56	3.81
G	13.39	13.64
H	5.13	5.38
I	0.64	0.89
J	2.92	3.18
K	2.41	2.67
L	15.24	16.51
M	2.29 Typical	
N	-	0.71
R	1.65 Typical	

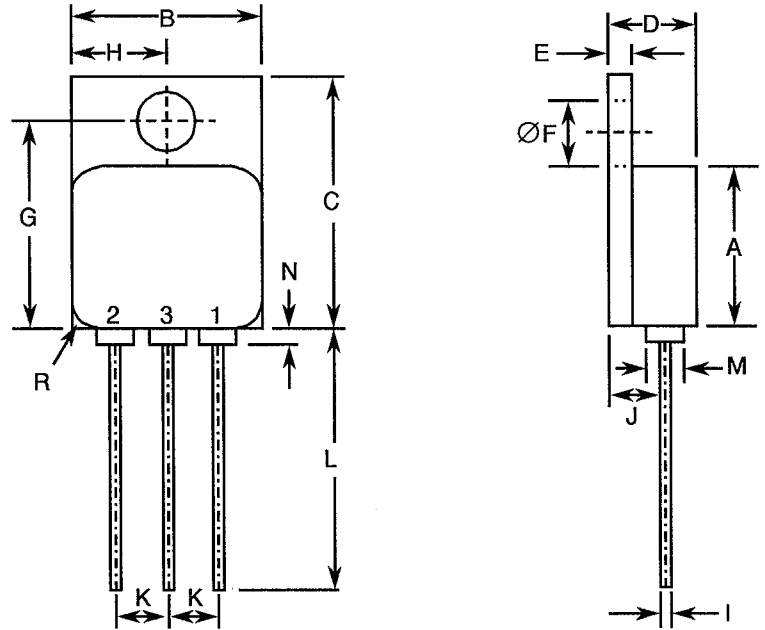
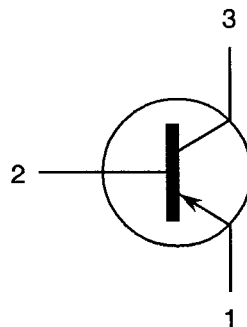


FIGURE 3 - FUNCTIONAL DIAGRAM



- 1. Emitter.
- 2. Base.
- 3. Collector.

NOTES

- 1. For Variants 01 to 05, the collector is internally connected to the case.
- 2. For Variants 06 to 07, the collector is isolated from the case.



4. REQUIREMENTS

4.1 GENERAL

The complete requirements for procurement of the transistors specified herein are stated in this specification and ESA/SCC Generic Specification No. 5000 for Discrete Semiconductors. Deviations from the Generic Specification applicable to this specification only, are listed in Para. 4.2.

Deviations from the applicable Generic Specification and this Detail Specification, formally agreed with specific Manufacturers on the basis that the alternative requirements are equivalent to the ESA/SCC requirements and do not affect the components' reliability, are listed in the appendices attached to this specification.

4.2 DEVIATIONS FROM GENERIC SPECIFICATION

4.2.1 Deviations from Special In-process Controls

None.

4.2.2 Deviations from Final Production Tests (Chart II)

None.

4.2.3 Deviations from Burn-in and Electrical Measurements (Chart III)

None.

4.2.4 Deviations from Qualification Tests (Chart IV)

None.

4.2.5 Deviations from Lot Acceptance Tests (Chart V)

None.

4.3 MECHANICAL REQUIREMENTS

4.3.1 Dimension Check

The dimensions of the transistors specified herein shall be checked. They shall conform to those shown in Figure 2.

4.3.2 Weight

The maximum weight of the transistors specified herein shall be 6.4 grammes for Variants 01 to 05 and 5.0 grammes for Variants 06 to 07.

4.3.3 Terminal Strength

The requirements for terminal strength testing are specified in Section 9 of ESA/SCC Generic Specification No. 5000. The test conditions shall be as follows:-

Test Condition : 'A', Tension.
Applied Force : 10N.
Duration : 10 seconds.



4.4 MATERIALS AND FINISHES

The materials and finishes shall be as specified herein. Where a definite material is not specified, a material which will enable the transistors specified herein to meet the performance requirements of this specification shall be used. Acceptance or approval of any constituent material does not guarantee acceptance of the finished product.

4.4.1 Case

For Variants 01 to 05, metal case, hermetically sealed, similar to JEDEC TO-66.

For Variants 06 to 07, the case shall be hermetically sealed and have a metal body, the Fe/Ni copper core pin shall pass through a ceramic eyelet brazed into the frame and the lid shall be welded.

4.4.2 Lead Material and Finish

For Variants 01 to 05, the lead material shall be Type 'D' or Type 'F' with either Type '2' or Type '3 or 4' finish, or Type 'F' with Type '9' finish in accordance with the requirements of ESA/SCC Basic Specification No. 23500. (See Table 1(a) for Type Variants).

For Variants 06 to 07, the lead material shall be Type 'H' with either Type '2' or Type '4' finish in accordance with the requirements of ESA/SCC Basic Specification No. 23500. (See Table 1(a) for Type Variants).

4.5 MARKING

4.5.1 General

The marking of all components delivered to this specification shall be in accordance with the requirements of ESA/SCC Basic Specification No. 21700 and the following paragraphs. When the component is too small to accommodate all of the marking specified, as much as space permits shall be marked and the marking information, in full, shall accompany the component in its primary package.

The information to be marked and the order of precedence, shall be as follows:-

- (a) Lead Identification.
- (b) The SCC Component Number.
- (c) Traceability Information.

4.5.2 Lead Identification

Lead identification shall be as shown in Figures 2 and 3.

4.5.3 The SCC Component Number

Each component shall bear the SCC Component Number which shall be constituted and marked as follows:

Detail Specification Number	_____	520400601B
Type Variant (See Table 1(a))	_____	
Testing Level (B or C, as applicable)	_____	



4.5.4 Traceability Information

Each component shall be marked in respect of traceability information in accordance with the requirements of ESA/SCC Basic Specification No. 21700.

4.6 ELECTRICAL MEASUREMENTS

4.6.1 Electrical Measurements at Room Temperature

The parameters to be measured at room temperature are scheduled in Table 2. Unless otherwise stated, the measurements shall be performed at $T_{amb} = +22 \pm 3$ °C.

4.6.2 Electrical Measurements at High and Low Temperatures

The parameters to be measured at high and low temperatures are scheduled in Table 3.

4.6.3 Circuits for Electrical Measurements

Circuits for use in performing the electrical measurements listed in Tables 2 and 3 are shown in Figure 4.

4.7 BURN-IN TESTS

4.7.1 Parameter Drift Values

The parameter drift values applicable to burn-in are specified in Table 4 of this specification. Unless otherwise stated, the measurements shall be performed at $T_{amb} = +22 \pm 3$ °C. The parameter drift values (Δ) applicable to the parameters scheduled, shall not be exceeded. In addition to these drift value requirements, the appropriate limit value specified for a given parameter in Table 2 shall not be exceeded.

4.7.2 Conditions for High Temperature Reverse Bias Burn-in

The requirements for high temperature reverse bias burn-in are specified in Section 7 of ESA/SCC Generic Specification No. 5000. The conditions for high temperature reverse bias burn-in shall be as specified in Table 5(a) of this specification.

4.7.3 Conditions for Power Burn-in

The requirements for power burn-in are specified in Section 7 of ESA/SCC Generic Specification No. 5000. The conditions for power burn-in shall be as specified in Table 5(b) of this specification.

4.7.4 Electrical Circuit for High Temperature Reverse Bias Burn-in

A circuit for use in performing the high temperature reverse bias burn-in tests is shown in Figure 5(a) of this specification.

4.7.5 Electrical Circuit for Power Burn-in

A circuit for use in performing the power burn-in tests is shown in Figure 5(b) of this specification.

4.7.6 Verification of Safe Operating Area

The requirement for the verification of the Safe Operating Area are specified in Section 9 of ESA/SCC Generic Specification No. 5000. The test method shall be as follows:-

Maximum continuous d.c. in accordance with MIL-STD-750, Method 3052 and Figure 1(b) of this specification, at $T_{case} = +25$ °C and for an operating time of 100ms maximum.

For Variants 01 to 07: $I_C = 2.0A$, $V_{CE} = 12V$.



TABLE 2 - ELECTRICAL MEASUREMENTS AT ROOM TEMPERATURE - d.c. PARAMETERS

No.	CHARACTERISTICS	SYMBOL	MIL-STD-750 TEST METHOD	TEST CONDITIONS	LIMITS		UNIT
					MIN	MAX	
1	Collector-Emitter Breakdown Voltage	$V_{(BR)CEO}$	3011	$I_C = -50\text{mA}$ $I_B = 0\text{A}$ Note 1	-80	-	V
2	Collector-Emitter Breakdown Voltage	$V_{(BR)CES}$	3011	$I_C = -2.0\text{mA}$ $V_{BE} = 0\text{V}$	-100	-	V
3	Emitter-Base Breakdown Voltage	$V_{(BR)EBO}$	3026	$I_E = -1.0\text{mA}$ $I_C = 0\text{A}$	-6.0	-	V
4	Collector-Emitter Cut-off Current	I_{CEO}	3041	$V_{CE} = -60\text{V}$ $I_B = 0\text{A}$	-	-10	μA
5	Collector-Base Cut-off Current	I_{CBO}	3036	$V_{CB} = -80\text{V}$ $I_E = 0\text{A}$	-	-0.5	μA
6	Emitter-Base Cut-off Current	I_{EBO}	3061	$V_{EB} = -4.0\text{V}$ $I_C = 0\text{A}$	-	-0.5	μA
7	D.C. Forward Current Transfer Ratio 1	h_{FE1}	3076	$V_{CE} = -5.0\text{V}$ $I_C = -500\text{mA}$ Note 1	70	-	-
8	D.C. Forward Current Transfer Ratio 2	h_{FE2}	3076	$V_{CE} = -5.0\text{V}$ $I_C = -2.0\text{A}$ Note 1	50	200	-
9	D.C. Forward Current Transfer Ratio 3	h_{FE3}	3076	$V_{CE} = -5.0\text{V}$ $I_C = -5.0\text{A}$ Note 1	30	-	-
10	Collector-Emitter Saturation Voltage	$V_{CE(SAT)}$	3071	$I_C = -5.0\text{A}$ $I_B = -0.5\text{A}$ Note 1	-	-1.0	V
11	Base-Emitter Saturation Voltage	$V_{BE(SAT)}$	3066	$I_C = -5.0\text{A}$ $I_B = -0.5\text{A}$ Note 1	-	-1.3	V

NOTES

1. Pulsed measurement: Pulse Length $\leq 300\mu\text{s}$, Duty Cycle $\leq 2.0\%$.
2. Saturation voltages measured 6.0mm from header.



TABLE 2 - ELECTRICAL MEASUREMENTS AT ROOM TEMPERATURE - a.c. PARAMETERS

No.	CHARACTERISTICS	SYMBOL	MIL-STD-750 TEST METHOD	TEST FIG.	TEST CONDITIONS (NOTE 1)	LIMITS		UNIT
						MIN	MAX	
12	A.C. Forward Current Transfer Ratio	h_{fe}	3206	-	$V_{CE} = -5.0$ $I_C = -0.5A$ $f = 20MHz$	2.5	-	-
13	Turn-on Time	t_{on}	-	4	$V_{BB} = 4.0V$ $V_{CC} = -40V$ $I_{B1} = -0.5A$ $I_{B2} = 0.5A$ $I_C = -5.0A$ $V_{IN} \approx -51V$	-	0.3	μs
14	Turn-off Time	t_{off}	-	4	$V_{BB} = 4.0V$ $V_{CC} = -40V$ $I_{B1} = -0.5A$ $I_{B2} = 0.5A$ $I_C = -5.0A$ $V_{IN} \approx -51V$	-	0.7	μs

NOTES

- Measurements shall be performed on a sample basis, LTPD7 or less.

TABLE 3 - ELECTRICAL MEASUREMENTS AT HIGH AND LOW TEMPERATURES

No.	CHARACTERISTICS	SYMBOL	TEST METHOD MIL-STD-750	TEST CONDITION	LIMITS		UNIT
					MIN.	MAX.	
5	Collector-Base Cut-off Current	I_{CBO}	3036	$V_{CE} = -80V$ $I_E = 0A$ $T_{amb} = +150^\circ C$	-	-150	μA
15	D.C. Forward Current Transfer Ratio 4	h_{FE4}	3076	$V_{CE} = -5.0V$ $I_C = -1.0A$ $T_{amb} = -55^\circ C$ Note 1	25	-	-

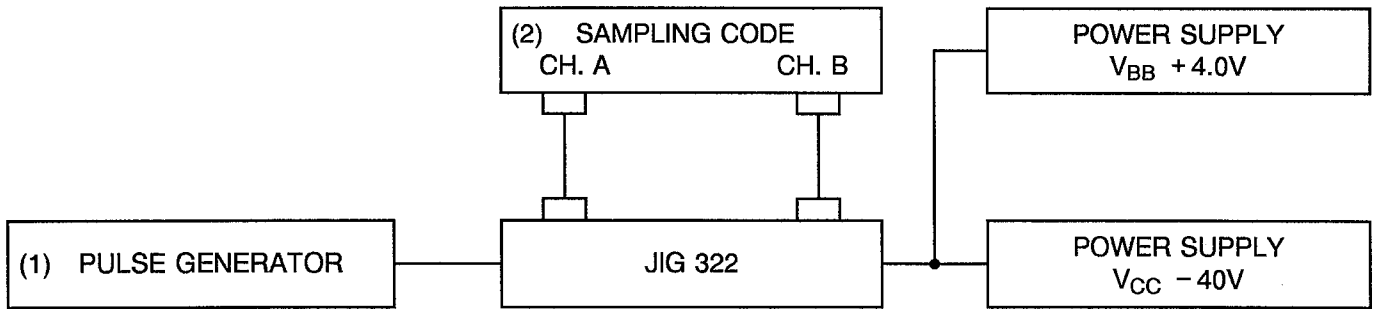
NOTES

- Pulsed measurement: Pulse Length $\leq 300\mu s$, Duty Cycle $\leq 2.0\%$.

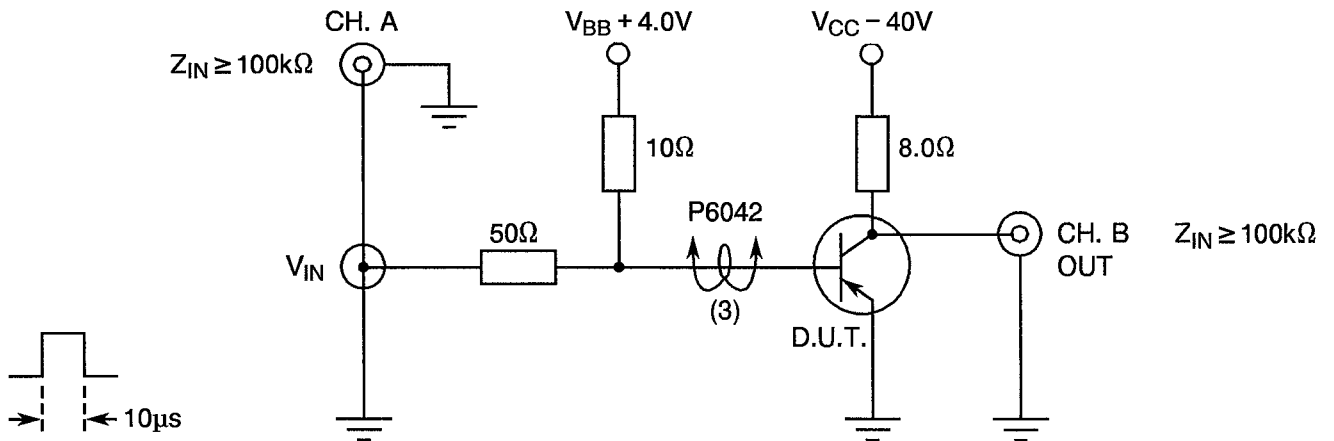


FIGURE 4 - CIRCUITS FOR ELECTRICAL MEASUREMENTS

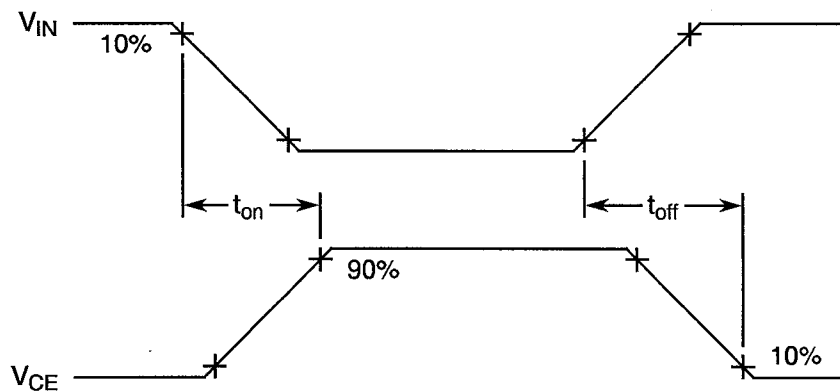
BLOCK DIAGRAM



EQUIVALENT TEST CIRCUIT



VOLTAGE WAVEFORMS



NOTES

1. Pulse generator Type E132 or equivalent, $t_r \leq 20ns$, $t_p = 10\mu s$, Duty Cycle = 1.0%.
2. Sampling Scope Tetronics 568 or equivalent.
3. Adjust $V_{IN} - V_B$ with current probe P6042.



TABLE 4 - PARAMETER DRIFT VALUES

No.	CHARACTERISTICS	SYMBOL	SPEC. AND/OR TEST METHOD	TEST CONDITIONS	CHANGE LIMITS (Δ)	UNIT
6	Emitter-Base Cut-off Current	I_{EBO}	As per Table 2	As per Table 2	± 100	nA
8	D.C. Forward Current Transfer Ratio 2	h_{FE2}	As per Table 2	As per Table 2	± 25	%
10	Collector-Emitter Saturation Voltage	$V_{CE(SAT)}$	As per Table 2	As per Table 2	± 100	mV

TABLE 5(a) - CONDITIONS FOR HIGH TEMPERATURE REVERSE BIAS BURN-IN

No.	CHARACTERISTIC	SYMBOL	CONDITIONS	UNIT
1	Ambient Temperature	T_{amb}	+ 150	$^{\circ}C$
2	Collector-Base Voltage	V_{CB}	- 80	V
3	Emitter-Base Voltage	V_{EB}	- 4.5	V
4	Duration	t	48	Hours

NOTES

1. No heat sink nor forced air directly on the device shall be permitted.

TABLE 5(b) - CONDITIONS FOR POWER BURN-IN AND OPERATING LIFE TESTS

No.	CHARACTERISTIC	SYMBOL	CONDITIONS	UNIT
1	Case Temperature	T_{case}	+ 100 (1)	$^{\circ}C$
2	Power Dissipation Variants 01 to 05 Variants 06 to 07	P_{tot}	22.8 20	W
3	Collector-Base Voltage	V_{CB}	- 10	V



FIGURE 5(a) - ELECTRICAL CIRCUIT FOR HIGH TEMPERATURE REVERSE BIAS BURN-IN

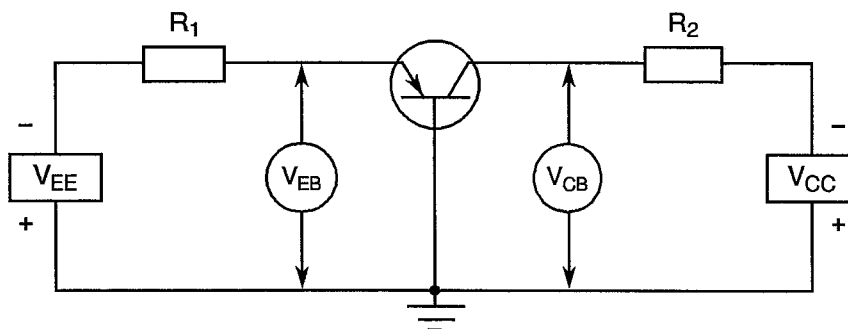
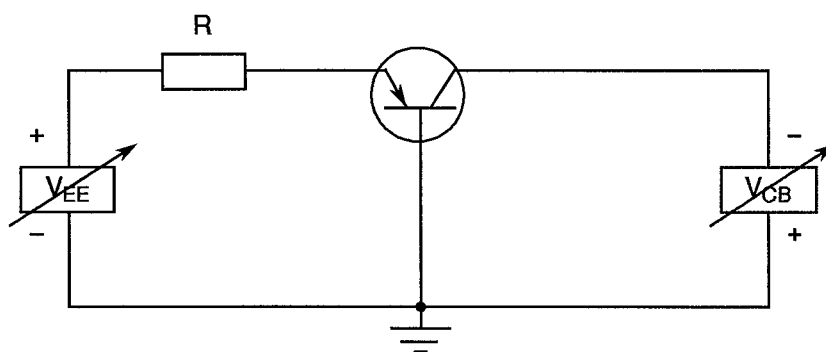


FIGURE 5(b) - ELECTRICAL CIRCUIT FOR POWER BURN-IN AND OPERATING LIFE TESTS





- 4.8 ENVIRONMENTAL AND ENDURANCE TESTS (CHARTS IV AND V OF ESA/SCC GENERIC SPECIFICATION NO. 5000)
- 4.8.1 Electrical Measurements on Completion of Environmental Tests
The parameters to be measured on completion of environmental tests are scheduled in Table 2. Unless otherwise stated, the measurements shall be performed at $T_{amb} = +22 \pm 3$ °C.
- 4.8.2 Electrical Measurements at Intermediate Points and on Completion of Endurance Tests
The parameters to be measured at intermediate points and on completion of endurance testing are scheduled in Table 6. Unless otherwise stated, the measurements shall be performed at $T_{amb} = +22 \pm 3$ °C.
- 4.8.3 Conditions for Operating Life Tests (Part of Endurance Testing)
The requirements for operating life testing are specified in Section 9 of ESA/SCC Generic Specification No. 5000. The conditions for operating life testing shall be the same as specified in Table 5(b) for the power burn-in test.
- 4.8.4 Electrical Circuit for Operating Life Tests
The circuit to be used for performance of the operating life test shall be the same as shown in Figure 5(b) for power burn-in.
- 4.8.5 Conditions for High Temperature Storage Test (Part of Endurance Testing)
The requirements for the high temperature storage test are specified in ESA/SCC Generic Specification No. 5000. The temperature to be applied shall be the maximum storage temperature specified in Table 1(b) of this specification.

**TABLE 6 - ELECTRICAL MEASUREMENTS AT INTERMEDIATE POINTS AND ON COMPLETION OF ENDURANCE TESTING**

No.	CHARACTERISTICS	SYMBOL	SPEC. AND/OR TEST METHOD	TEST CONDITION	LIMITS		UNIT
					MIN.	MAX.	
4	Collector-Emitter Cut-off Current	I_{CEO}	As per Table 2	As per Table 2	-	- 10	μA
8	D.C. Forward Current Transfer Ratio 2	h_{FE2}	As per Table 2	As per Table 2	50	200	-
10	Collector-Emitter Saturation Voltage	$V_{CE(SAT)}$	As per Table 2	As per Table 2	-	- 1.0	V