



Pages 1 to 29

**INTEGRATED CIRCUITS, SILICON MONOLITHIC, CMOS  
ANALOGUE MULTIPLEXER/DEMULTIPLEXER  
(DIFFERENTIAL 4-CHANNEL)**

**BASED ON TYPE 4052B**

**ESCC Detail Specification No. 9202/048**

Issue 2	September 2004
---------	----------------



Document Custodian: European Space Agency - see <https://escies.org>

**LEGAL DISCLAIMER AND COPYRIGHT**

European Space Agency, Copyright © 2004. All rights reserved.

The European Space Agency disclaims any liability or responsibility, to any person or entity, with respect to any loss or damage caused, or alleged to be caused, directly or indirectly by the use and application of this ESCC publication.

This publication, without the prior permission of the European Space Agency and provided that it is not used for a commercial purpose, may be:

- copied in whole, in any medium, without alteration or modification.
- copied in part, in any medium, provided that the ESCC document identification, comprising the ESCC symbol, document number and document issue, is removed.

**DOCUMENTATION CHANGE NOTICE**

(Refer to <https://escies.org> for ESCC DCR content)

DCR No.	CHANGE DESCRIPTION
120, 90	Specification up issued to incorporate editorial and technical changes per DCR.

**TABLE OF CONTENTS**

<b>1.</b>	<b><u>GENERAL</u></b>	<b>5</b>
1.1	Scope	5
1.2	Applicable Documents	5
1.3	Terms, Definitions, Abbreviations, Symbols and Units	5
1.4	The ESCC Component Number and Component Type Variants	5
1.4.1	The ESCC Component Number	5
1.4.2	Component Type Variants	5
1.5	Maximum Ratings	6
1.6	Handling Precautions	6
1.7	Physical Dimensions and Terminal Identification	7
1.7.1	Flat Package (FP) - 16 Pin	7
1.7.2	Dual-in-line Package (DIP) - 16 Pin	8
1.7.3	Chip Carrier Package (CCP) - 20 Terminal	9
1.7.4	Small Outline Ceramic Package (SO) - 16 Pin	11
1.7.5	Consolidated Notes	12
1.8	Functional Diagram	12
1.9	Pin Assignment	14
1.10	Truth Table	14
1.11	Input Protection Network	15
<b>2.</b>	<b><u>REQUIREMENTS</u></b>	<b>15</b>
2.1	General	15
2.1.1	Deviations from the Generic Specification	16
2.2	Marking	16
2.3	Electrical Measurements at Room, High and Low Temperatures	16
2.3.1	Room Temperature Electrical Measurements	16
2.3.2	High and Low Temperatures Electrical Measurements	19
2.3.3	Notes to Electrical Measurement Tables	22
2.4	Parameter Drift Values	24
2.5	Intermediate and End-Point Electrical Measurements	25
2.6	High Temperature Reverse Bias Burn-In Conditions	27
2.6.1	N-Channel HTRB	27
2.6.2	P-Channel HTRB	27
2.7	Power Burn-In Conditions	28
2.8	Operating Life Conditions	28
APPENDIX 'A'		29

## 1. GENERAL

### 1.1 SCOPE

This specification details the ratings, physical and electrical characteristics and test and inspection data for the component type variants and/or the range of components specified below. It supplements the requirements of, and shall be read in conjunction with, the ESCC Generic Specification listed under Applicable Documents.

### 1.2 APPLICABLE DOCUMENTS

The following documents form part of this specification and shall be read in conjunction with it:

- (a) ESCC Generic Specification No. 9000
- (b) MIL-STD-883, Test Methods and Procedures for Microelectronics

### 1.3 TERMS, DEFINITIONS, ABBREVIATIONS, SYMBOLS AND UNITS

For the purpose of this specification, the terms, definitions, abbreviations, symbols and units specified in ESCC Basic Specification No. 21300 shall apply.

### 1.4 THE ESCC COMPONENT NUMBER AND COMPONENT TYPE VARIANTS

#### 1.4.1 The ESCC Component Number

The ESCC Component Number shall be constituted as follows:

Example: 920204801

- Detail Specification Reference: 9202048
- Component Type Variant Number: 01 (as required)

#### 1.4.2 Component Type Variants

The component type variants applicable to this specification are as follows:

Variant Number	Based on Type	Case	Terminal Material and /or Finish	Weight max g
01	4052B	FP	G2	0.7
02	4052B	FP	G4	0.7
07	4052B	CCP	2	0.6
08	4052B	DIP	G2	2.2
09	4052B	DIP	G4	2.2
10	4052B	SO	G2	0.7
11	4052B	SO	G4	0.7

The terminal material and/or finish shall be in accordance with the requirements of ESCC Basic Specification No. 23500.

1.5 **MAXIMUM RATINGS**

The maximum ratings shall not be exceeded at any time during use or storage.

Maximum ratings shall only be exceeded during testing to the extent specified in this specification and when stipulated in Test Methods and Procedures of the ESCC Generic Specification.

Characteristics	Symbols	Maximum Ratings	Units	Remarks
Supply Voltage	$V_{DD}$	-0.5 to 18	V	Note 1
Supply Voltage Range	$V_{DD}-V_{EE}$	-0.5 to 18	V	Note 2
Control Input Voltage	$V_{IN}$	-0.5 to $V_{DD} +0.5$	V	Note 1 Power on
Channel Input/Output Voltage	$V_{IN}$	$V_{EE} -0.5$ to $V_{DD} +0.5$	V	Note 1, 3
Control Input Current	$I_{IN}$	$\pm 10$	mA	-
Device Power Dissipation (Continuous)	$P_D$	200	mW	-
Power Dissipation per Single Output	$P_{DSO}$	100	mW	-
Operating Temperature Range	$T_{op}$	-55 to +125	$^{\circ}C$	$T_{amb}$
Storage Temperature Range	$T_{stg}$	-65 to +150	$^{\circ}C$	-
Soldering Temperature For FP, DIP and SO For CCP	$T_{sol}$	+265 +245	$^{\circ}C$	Note 4 Note 5

**NOTES:**

1. Device is functional for  $3V \leq V_{DD} \leq 15V$  with reference to  $V_{SS}$ .
2. Device is functional for  $3V \leq V_{DD}-V_{EE} \leq 15V$ .
3. To avoid draining  $V_{DD}$  supply current into the ON Channel when current flows from CH to COM the voltage drop across the ON Channel shall not exceed 0.4V.
4. Duration 10 seconds maximum at a distance of not less than 1.5mm from the device body and the same terminal shall not be resoldered until 3 minutes have elapsed.
5. Duration 5 seconds maximum and the same terminal shall not be resoldered until 3 minutes have elapsed.

1.6 **HANDLING PRECAUTIONS**

These devices are susceptible to damage by electrostatic discharge. Therefore, suitable precautions shall be employed for protection during all phases of manufacture, testing, packaging, shipment and any handling.

These components are categorised as Class 1 per ESCC Basic Specification No. 23800 with a minimum Critical Path Failure Voltage of 400 Volts.

1.7 **PHYSICAL DIMENSIONS AND TERMINAL IDENTIFICATION**

Consolidated Notes are given following the case drawings and dimensions.

1.7.1 **Flat Package (FP) - 16 Pin**

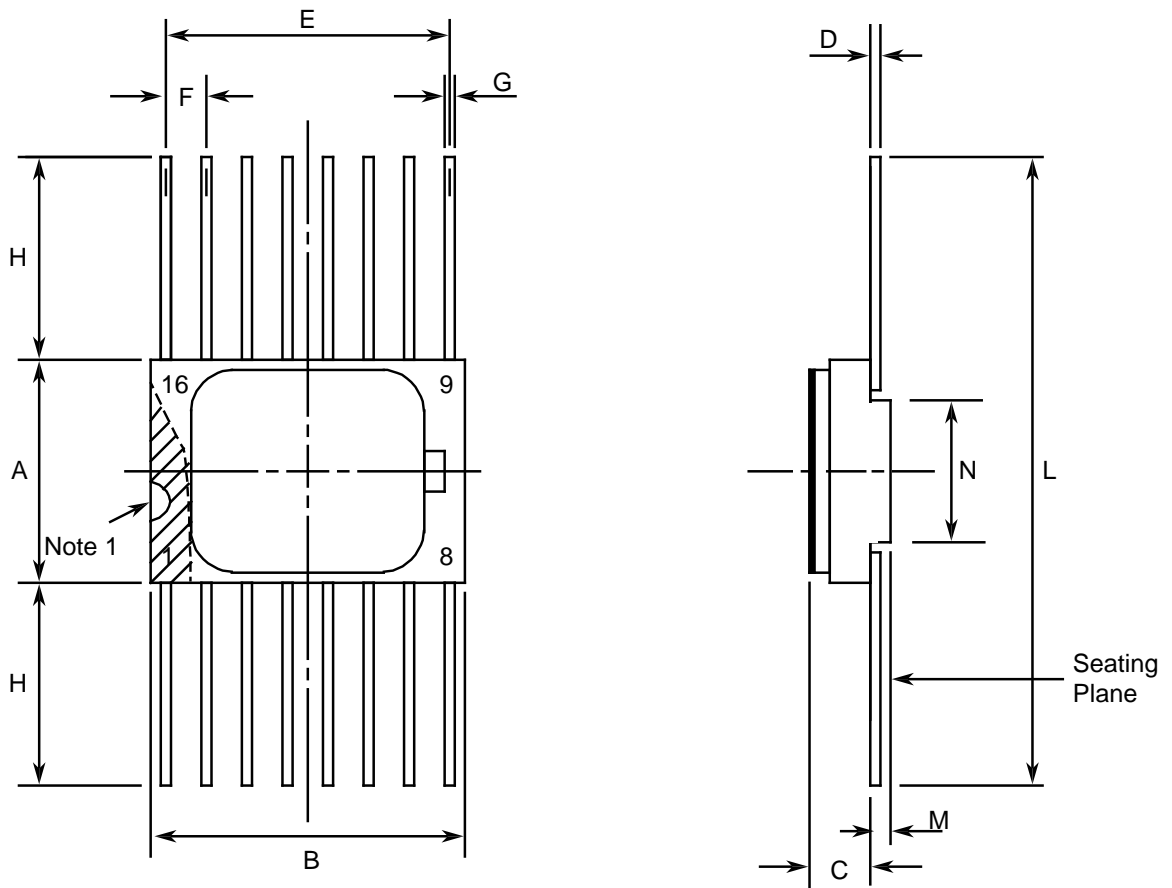

Symbols	Dimensions mm		Notes
	Min	Max	
A	6.75	7.06	
B	9.76	10.14	
C	1.49	1.95	
D	0.1	0.15	5
E	8.76	9.01	
F	1.27 TYPICAL		3, 6
G	0.38	0.48	5
H	6	-	5
L	18.75	22	
M	0.33	0.43	

Symbols	Dimensions mm		Notes
	Min	Max	
N	4.32 TYPICAL		

1.7.2 Dual-in-line Package (DIP) - 16 Pin

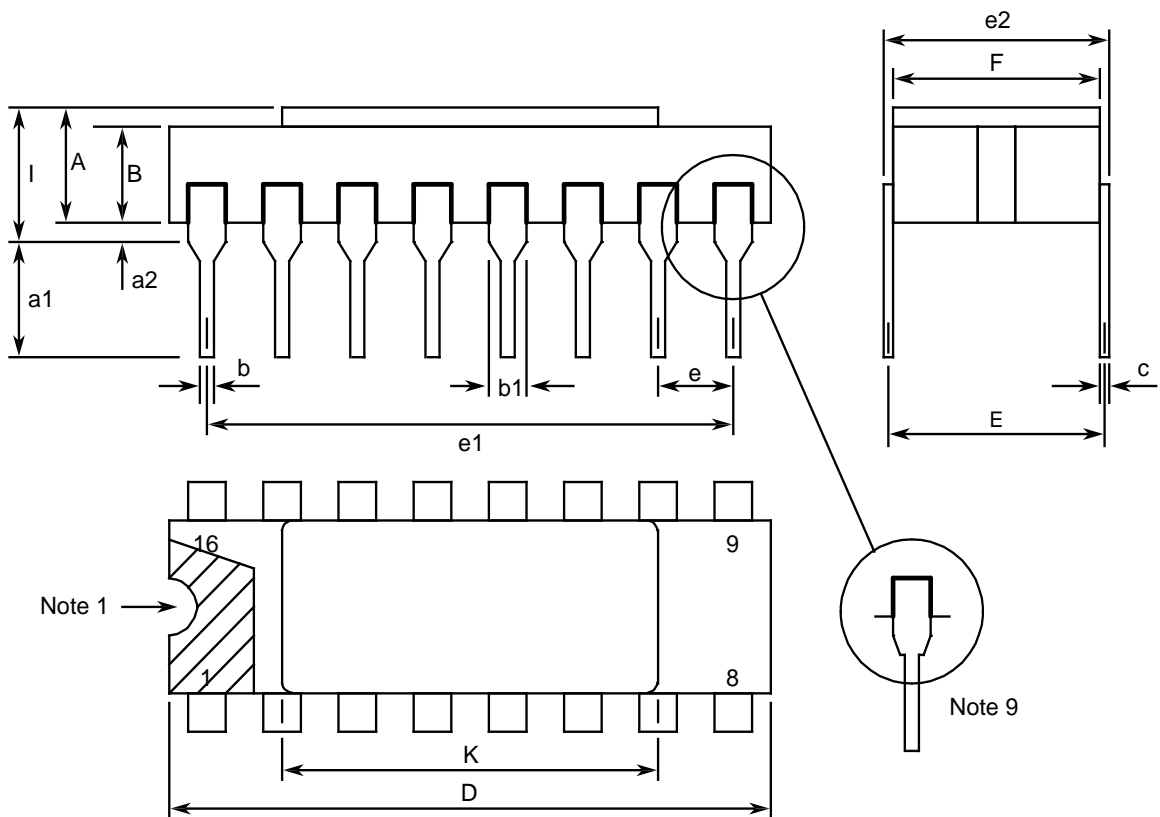

Symbols	Dimensions mm		Notes
	Min	Max	
A	2.1	2.71	
a1	3	3.7	
a2	0.63	1.14	2
B	1.82	2.39	
b	0.4	0.5	5
b1	1.14	1.5	5
c	0.2	0.3	5
D	20.06	20.58	
E	7.36	7.87	



Symbols	Dimensions mm		Notes
	Min	Max	
e	2.54 TYPICAL		4, 6
e1	17.65	17.9	
e2	7.62	8.12	
F	7.29	7.7	
l	-	3.83	
K	10.9	12.1	

1.7.3 Chip Carrier Package (CCP) - 20 Terminal

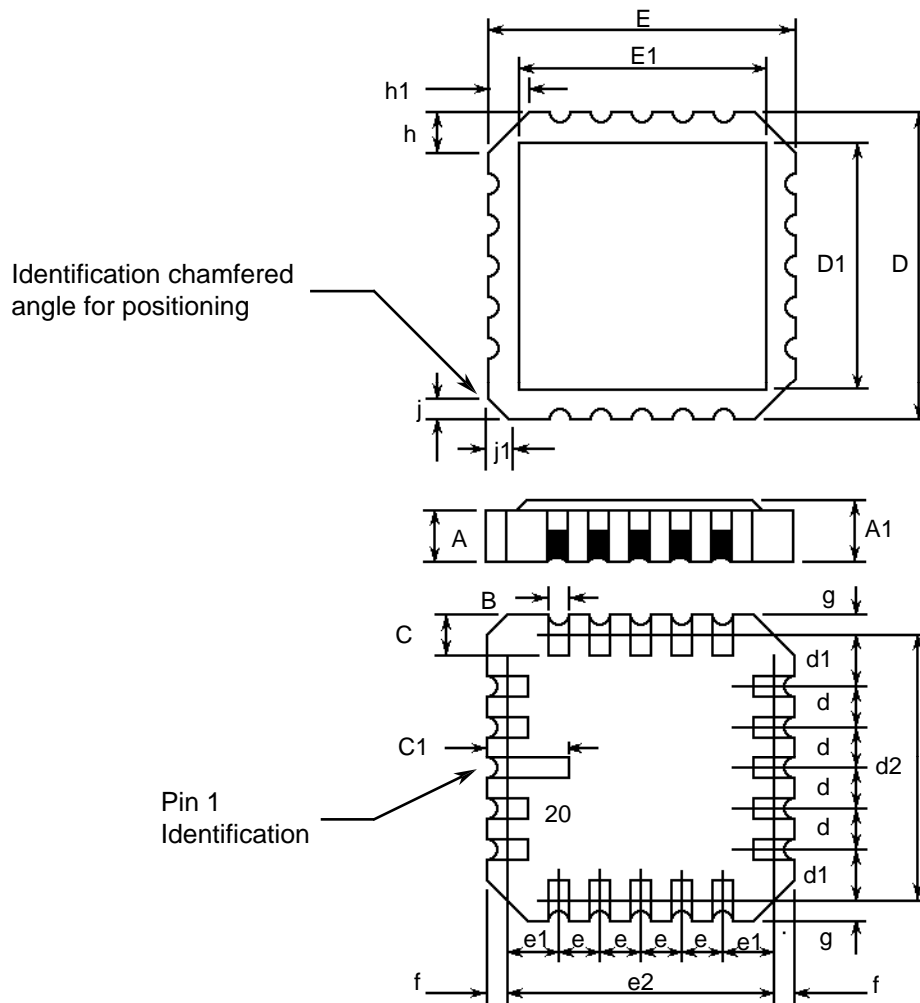

Symbols	Dimensions mm		Notes
	Min	Max	
A	1.14	1.95	
A1	1.63	2.36	
B	0.55	0.72	5
C	1.06	1.47	5
C1	1.91	2.41	
D	8.67	9.09	
D1	7.21	7.52	
d, d1	1.27 TYPICAL		3, 6
d2	7.62 TYPICAL		
E	8.67	9.09	
E1	7.21	7.52	
e, e1	1.27 TYPICAL		3, 6
e2	7.62 TYPICAL		
f, g	-	0.76	
h, h1	1.01 TYPICAL		8
j, j1	0.51 TYPICAL		7

1.7.4 Small Outline Ceramic Package (SO) - 16 Pin

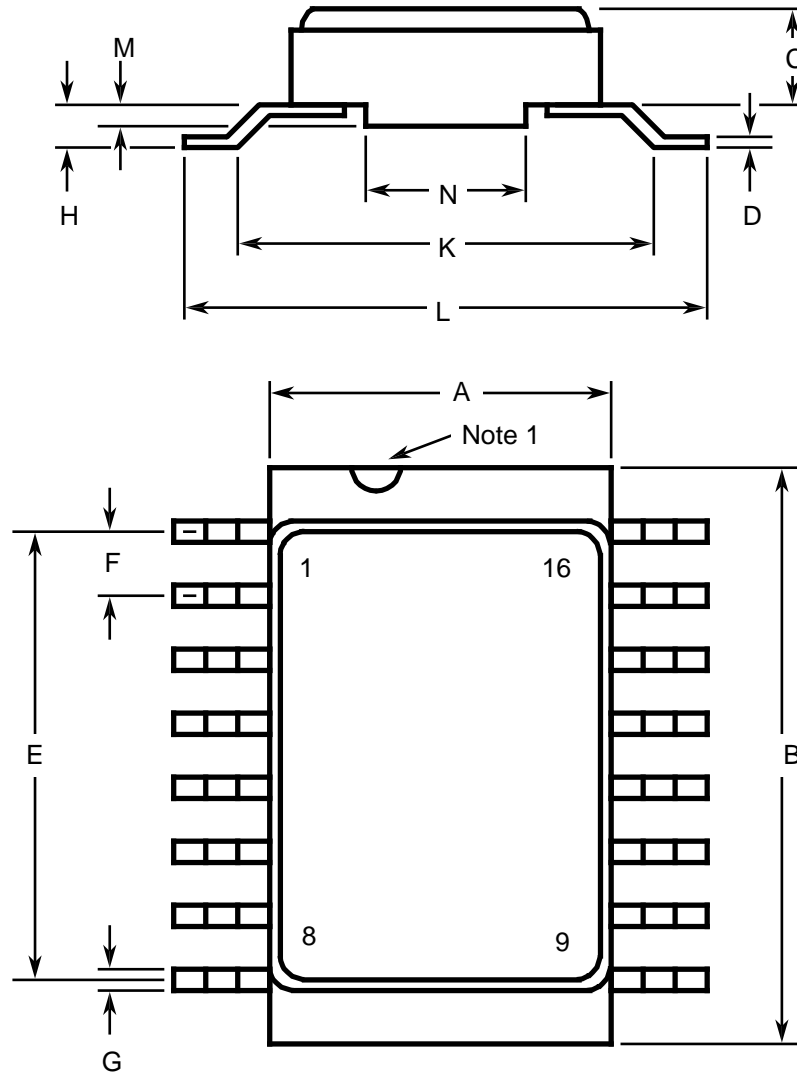

Symbols	Dimensions mm		Notes
	Min	Max	
A	6.75	7.06	
B	9.76	10.14	
C	1.49	1.95	
D	0.1	0.15	5
E	8.76	9.01	
F	1.27 TYPICAL		3, 6
G	0.38	0.48	5
H	0.6	0.9	5

Symbols	Dimensions mm		Notes
	Min	Max	
K	9 TYPICAL		
L	10	10.65	
M	0.33	0.43	
N	4.31 TYPICAL		

1.7.5 Consolidated Notes

1. Index area; a notch or a dot shall be located adjacent to Pin 1 and shall be within the shaded area shown. For chip carrier packages, the index shall be as shown.
2. The dimension shall be measured from the seating plane to the base plane.
3. The true position pin spacing is 1.27mm between centrelines. Each pin centreline shall be located within  $\pm 0.13$ mm of its true longitudinal position relative to Pin 1 and the highest pin number.
4. The true position pin spacing is 2.54mm between centrelines. Each pin centreline shall be located within  $\pm 0.25$ mm of its true longitudinal position relative to Pin 1 and the highest pin number.
5. All terminals.
6. 14 spaces for flat, dual-in-line and small outline packages.  
16 spaces for chip carrier packages.
7. Index corner only - 2 dimensions.
8. 3 non-index corners - 6 dimensions.
9. For all pins, either pin shape may be supplied.

1.8 FUNCTIONAL DIAGRAM

Pin numbers relate to FP, DIP and SO packages only.

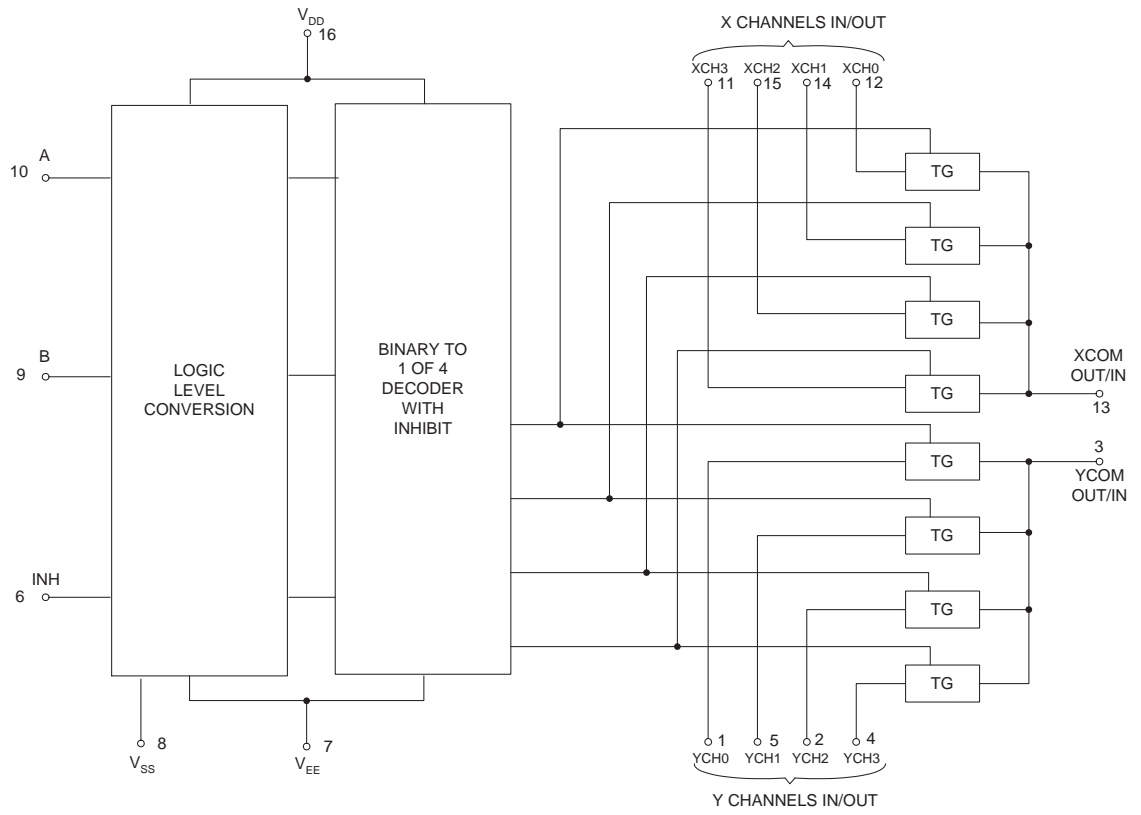

1.9 PIN ASSIGNMENT

Pin	Function		Pin	Function	
	FP, DIP and SO	CCP		FP, DIP and SO	CCP
1	YCH0 Input/Output (Channel)	YCH0 Input/Output (Channel)	11	XCH3 Input/Output (Channel)	B Input (Select)
2	YCH2 Input/Output (Channel)	YCH2 Input/Output (Channel)	12	XCH0 Input/Output (Channel)	A Input (Select)
3	YCOM Output/Input (Common)	-	13	XCOM Output/Input (Common)	-
4	YCH3 Input/Output (Channel)	YCOM Output/Input (Common)	14	XCH1 Input/Output (Channel)	XCH3 Input/Output (Channel)
5	YCH1 Input/Output (Channel)	YCH3 Input/Output (Channel)	15	XCH2 Input/Output (Channel)	XCH0 Input/Output (Channel)
6	INH Input (Inhibit)	YCH1 Input/Output (Channel)	16	V <sub>DD</sub>	XCOM Output/Input (Common)
7	V <sub>EE</sub> (Analogue Negative Supply)	INH Input (Inhibit)	17	-	XCH1 Input/Output (Channel)
8	V <sub>SS</sub> (Digital Negative Supply)	-	18	-	-
9	B Input (Select)	V <sub>EE</sub> (Analogue Negative Supply)	19	-	XCH2 Input/Output (Channel)
10	A Input (Select)	V <sub>SS</sub> (Digital Negative Supply)	20	-	V <sub>DD</sub>

1.10 TRUTH TABLE

- Logic Level Definitions: L = Low Level, H = High Level, X =Irrelevant.

CONTROL INPUTS			ON CHANNELS
INH	SELECT		
	B	A	
L	L	L	XCH0 to XCOM, XCOM to XCH0 YCH0 to YCOM, YCOM to YCH0
L	L	H	XCH1 to XCOM, XCOM to XCH1 YCH1 to YCOM, YCOM to YCH1
L	H	L	XCH2 to XCOM, XCOM to XCH2 YCH2 to YCOM, YCOM to YCH2
L	H	H	XCH3 to XCOM, XCOM to XCH3 YCH3 to YCOM, YCOM to YCH3
H	X	X	NONE (High Impedance)

1.11 INPUT PROTECTION NETWORK  
(CONTROL INPUTS)

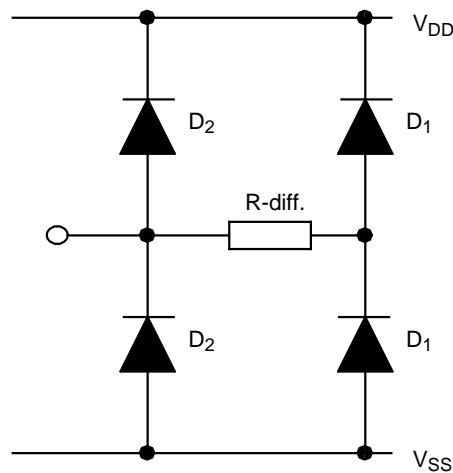

2. REQUIREMENTS

2.1 GENERAL

The complete requirements for procurement of the components specified herein are as stated in this specification and the ESCC Generic Specification. Permitted deviations from the Generic Specification, applicable to this specification only, are listed below.

Permitted deviations from the Generic Specification and this Detail Specification, formally agreed with specific Manufacturers on the basis that the alternative requirements are equivalent to the ESCC requirement and do not affect the component's reliability, are listed in the appendices attached to this specification.

2.1.1 Deviations from the Generic Specification

None.

2.2 MARKING

The marking shall be in accordance with the requirements of ESCC Basic Specification No. 21700 and as follows.

The information to be marked on the component shall be:

- (a) Terminal identification.
- (b) The ESCC qualified components symbol (for ESCC qualified components only).
- (c) The ESCC Component Number.
- (d) Traceability information.

2.3 ELECTRICAL MEASUREMENTS AT ROOM, HIGH AND LOW TEMPERATURES

Electrical measurements shall be performed at room, high and low temperatures. Consolidated Notes are given after the tables.

2.3.1 Room Temperature Electrical Measurements

The measurements shall be performed at  $T_{amb}=+22 \pm 3^{\circ}C$ .

Characteristics	Symbols	MIL-STD-883 Test Method	Test Conditions Note 1	Limits		Units
				Min	Max	
Functional Test 1	-	3014	Verify Truth Table $V_{IL}=0V, V_{IH}=3V$ $V_{DD}=3V, V_{SS}=V_{EE}=0V$ Note 2	-	-	-
Functional Test 2	-	3014	Verify Truth Table $V_{IL}=0V, V_{IH}=15V$ $V_{DD}=15V,$ $V_{SS}=V_{EE}=0V$ Note 2	-	-	-
Quiescent Current	$I_{DD}$	3005	$V_{IL}=0V, V_{IH}=15V$ $V_{DD}=15V,$ $V_{SS}=V_{EE}=0V$ Note 3	-	1	$\mu A$
Low Level Input Current, Control Inputs	$I_{IL}$	3009	$V_{IN}$ (Under Test)=0V $V_{DD}=15V,$ $V_{SS}=V_{EE}=0V$	-	-50	nA
High Level Input Current, Control Inputs	$I_{IH}$	3010	$V_{IN}$ (Under Test)=15V $V_{DD}=15V,$ $V_{SS}=V_{EE}=0V$	-	50	nA



Characteristics	Symbols	MIL-STD-883 Test Method	Test Conditions Note 1	Limits		Units
				Min	Max	
Channel OFF Leakage Current 1, Any Channel CH	$I_{OFF1}$	-	Channel Under Test $V_{IN}(CH)=15V$ $V_{IN}(COM)=0V$ All other Channels Open $V_{DD}=15V,$ $V_{SS}=V_{EE}=0V$	-	-100	nA
Channel OFF Leakage Current 2, Any Channel CH	$I_{OFF2}$	-	Channel Under Test $V_{IN}(CH)=0V$ $V_{IN}(COM)=15V$ All other Channels Open $V_{DD}=15V,$ $V_{SS}=V_{EE}=0V$	-	100	nA
Channel OFF Leakage Current 3, All Channels Tested Together	$I_{OFF3}$	-	$V_{IN}(CH)=0V$ $V_{IN}(COM)=15V$ $V_{DD}=15V,$ $V_{SS}=V_{EE}=0V$	-	100	nA
Channel OFF Leakage Current 4, All Channels Tested Together	$I_{OFF4}$	-	$V_{IN}(CH)=15V$ $V_{IN}(COM)=0V$ $V_{DD}=15V,$ $V_{SS}=V_{EE}=0V$	-	-100	nA
Channel ON Resistance 1	$R_{ON1}$	-	$V_{IL}=0V, V_{IH}=5V$ $R_L=10k\Omega$ $V_{DD}=5V, V_{SS}=V_{EE}=0V$ Note 4	-	1050	$\Omega$
Channel ON Resistance 2	$R_{ON2}$	-	$V_{IL}=0V, V_{IH}=15V$ $R_L=10k\Omega$ $V_{DD}=15V,$ $V_{SS}=V_{EE}=0V$ Note 4	-	280	$\Omega$
Low Level Input Voltage 1 (Noise Immunity) (Functional Test)	$V_{IL1}$	-	Verify Truth Table $V_{DD}=5V, V_{SS}=V_{EE}=0V$ Note 5	-	1.5	V
Low Level Input Voltage 2 (Noise Immunity) (Functional Test)	$V_{IL2}$	-	Verify Truth Table $V_{DD}=15V,$ $V_{SS}=V_{EE}=0V$ Note 5	-	4	V
High Level Input Voltage 1 (Noise Immunity) (Functional Test)	$V_{IH1}$	-	Verify Truth Table $V_{DD}=5V, V_{SS}=V_{EE}=0V$ Note 5	3.5	-	V

Characteristics	Symbols	MIL-STD-883 Test Method	Test Conditions Note 1	Limits		Units
				Min	Max	
High Level Input Voltage 2 (Noise Immunity) (Functional Test)	$V_{IH2}$	-	Verify Truth Table $V_{DD}=15V$ , $V_{SS}=V_{EE}=0V$ Note 5	11	-	V
Threshold Voltage N-Channel	$V_{THN}$	-	INH Input and $V_{EE}$ at Ground All Other Inputs: $V_{IN}=5V$ $V_{DD}=5V$ , $I_{SS}=-10\mu A$	-0.7	-3	V
Threshold Voltage P-Channel	$V_{THP}$	-	INH Input at Ground All Other Inputs: $V_{IN}=-5V$ $V_{SS}=V_{EE}=-5V$ , $I_{DD}=3.5\mu A$	0.7	3	V
Input Clamp Voltage 1, to $V_{SS}$ , Control Inputs	$V_{IC1}$	-	$I_{IN}$ (Under Test)=- -100 $\mu A$ $V_{DD}=\text{Open}$ , $V_{SS}=0V$ All Other Pins Open	-	-2	V
Input Clamp Voltage 2, to $V_{DD}$ , Control Inputs	$V_{IC2}$	-	$V_{IN}$ (Under Test)=6V $R=30k\Omega$ , $V_{SS}=\text{Open}$ All Other Pins Open Note 6	3	-	V
Input Capacitance, Control Inputs	$C_{IN}$	3012	$V_{IN}$ (Not Under Test)=0V $V_{DD}=V_{SS}=V_{EE}=0V$ $f=100\text{ kHz to }1\text{ MHz}$ Note 7	-	7.5	pF
Channel Capacitance, CH	$C_{CH}$	3012	$V_{IN}$ (Not Under Test)=0V $V_{DD}=V_{SS}=V_{EE}=0V$ $f=100\text{ kHz to }1\text{ MHz}$ Note 7	-	7.5	pF
Channel Capacitance, XCOM, YCOM	$C_{COM}$	3012	$V_{IN}$ (Not Under Test)=0V $V_{DD}=V_{SS}=V_{EE}=0V$ $f=100\text{ kHz to }1\text{ MHz}$ Note 7	-	30	pF
Propagation Delay Low to High, XCOM to XCH0	$t_{PLH}$	3003	$V_{IN}(\text{COM})=\text{Pulse Generator}$ $V_{IN}$ (Remaining Inputs)=Truth Table $V_{IL}=0V$ , $V_{IH}=5V$ , $R_L=200k\Omega$ $V_{DD}=5V$ , $V_{SS}=V_{EE}=0V$ Note 8	-	40	ns

Characteristics	Symbols	MIL-STD-883 Test Method	Test Conditions Note 1	Limits		Units
				Min	Max	
Propagation Delay High to Low, XCOM to XCH0	$t_{PHL}$	3003	$V_{IN}(COM)=$ Pulse Generator $V_{IN}$ (Remaining Inputs)=Truth Table $V_{IL}=0V, V_{IH}=5V,$ $R_L=200k\Omega$ $V_{DD}=5V, V_{SS}=V_{EE}=0V$ Note 8	-	40	ns
Output Enable Time High Impedance to High Output 1, A to YCOM	$t_{PZH1}$	3003	$V_{IN}(A)=$ Pulse Generator $V_{IN}$ (Remaining Inputs)=Truth Table $V_{IL}=0V, V_{IH}=5V,$ $V_{IN}(CH)=5V$ and Open $R_L=10k\Omega$ $V_{DD}=5V, V_{SS}=V_{EE}=0V$ Note 8	-	720	ns
Output Disable Time High Output to High Impedance 1, A to YCOM	$t_{PHZ1}$	3003	$V_{IN}(A)=$ Pulse Generator $V_{IN}$ (Remaining Inputs)=Truth Table $V_{IL}=0V, V_{IH}=5V,$ $V_{IN}(CH)=5V$ and Open $R_L=300\Omega$ $V_{DD}=5V, V_{SS}=V_{EE}=0V$ Note 8	-	720	ns
Output Enable Time High Impedance to High Output 2, INH to YCOM	$t_{PZH2}$	3003	$V_{IN}(INH)=$ Pulse Generator $V_{IN}$ (Remaining Inputs)=Truth Table $V_{IL}=0V, V_{IH}=5V,$ $V_{IN}(CH)=5V, R_L=10k\Omega$ $V_{DD}=5V, V_{SS}=V_{EE}=0V$ Note 8	-	400	ns
Output Disable Time High Output to High Impedance 2, INH to YCOM	$t_{PHZ2}$	3003	$V_{IN}(INH)=$ Pulse Generator $V_{IN}$ (Remaining Inputs)=Truth Table $V_{IL}=0V, V_{IH}=5V,$ $V_{IN}(CH)=5V, R_L=300\Omega$ $V_{DD}=5V, V_{SS}=V_{EE}=0V$ Note 8	-	400	ns

2.3.2 High and Low Temperatures Electrical Measurements

The measurements shall be performed at  $T_{amb}=+125 (+0 -5) ^\circ C$  and  $T_{amb}=- 55(+5-0)^\circ C$ .

Characteristics	Symbols	MIL-STD-883 Test Method	Test Conditions Note 1	Limits		Units
				Min	Max	
Functional Test 1	-	3014	Verify Truth Table $V_{IL}=0V, V_{IH}=3V$ $V_{DD}=3V,$ $V_{SS}=V_{EE}=0V$ Note 2	-	-	-
Functional Test 2	-	3014	Verify Truth Table $V_{IL}=0V, V_{IH}=15V$ $V_{DD}=15V,$ $V_{SS}=V_{EE}=0V$ Note 2	-	-	-
Quiescent Current	$I_{DD}$	3005	$V_{IL}=0V, V_{IH}=15V$ $V_{DD}=15V,$ $V_{SS}=V_{EE}=0V$ Note 3 $T_{amb}=+125^{\circ}C$ $T_{amb}=-55^{\circ}C$	-	30 1	$\mu A$
Low Level Input Current, Control Inputs	$I_{IL}$	3009	$V_{IN}$ (Under Test)=0V $V_{DD}=15V,$ $V_{SS}=V_{EE}=0V$ $T_{amb}=+125^{\circ}C$ $T_{amb}=-55^{\circ}C$	-	-100 -50	nA
High Level Input Current, Control Inputs	$I_{IH}$	3010	$V_{IN}$ (Under Test)=15V $V_{DD}=15V,$ $V_{SS}=V_{EE}=0V$ $T_{amb}=+125^{\circ}C$ $T_{amb}=-55^{\circ}C$	-	100 50	nA
Channel OFF Leakage Current 1, Any Channel CH	$I_{OFF1}$	-	Channel Under Test $V_{IN}$ (CH)=15V $V_{IN}$ (COM)=0V All other Channels Open $V_{DD}=15V,$ $V_{SS}=V_{EE}=0V$ $T_{amb}=+125^{\circ}C$ $T_{amb}=-55^{\circ}C$	-	-1 -0.1	$\mu A$
Channel OFF Leakage Current 2, Any Channel CH	$I_{OFF2}$	-	Channel Under Test $V_{IN}$ (CH)=0V $V_{IN}$ (COM)=15V All other Channels Open $V_{DD}=15V,$ $V_{SS}=V_{EE}=0V$ $T_{amb}=+125^{\circ}C$ $T_{amb}=-55^{\circ}C$	-	1 0.1	$\mu A$

Characteristics	Symbols	MIL-STD-883 Test Method	Test Conditions Note 1	Limits		Units
				Min	Max	
Channel OFF Leakage Current 3, All Channels Tested Together	$I_{OFF3}$	-	$V_{IN} (CH)=0V$ $V_{IN} (COM)=15V$ $V_{DD}=15V,$ $V_{SS}=V_{EE}= 0V$ $T_{amb}=+125^{\circ}C$ $T_{amb}=- 55^{\circ}C$	- -	1 0.1	$\mu A$
Channel OFF Leakage Current 4, All Channel Tested Together	$I_{OFF4}$	-	$V_{IN} (CH)=15V$ $V_{IN} (COM)=0V$ $V_{DD}=15V,$ $V_{SS}=V_{EE}= 0V$ $T_{amb}=+125^{\circ}C$ $T_{amb}=- 55^{\circ}C$	- -	-1 -0.1	$\mu A$
Channel ON Resistance 1	$R_{ON1}$	-	$V_{IL}=0V, V_{IH}=5V$ $R_L=10k\Omega$ $V_{DD}=5V, V_{SS}=V_{EE}= 0V$ Note 4 $T_{amb}=+125^{\circ}C$ $T_{amb}=- 55^{\circ}C$	- -	1200 880	$\Omega$
Channel ON Resistance 2	$R_{ON2}$	-	$V_{IL}=0V, V_{IH}=15V$ $R_L=10k\Omega$ $V_{DD}=15V,$ $V_{SS}=V_{EE}= 0V$ Note 4 $T_{amb}=+125^{\circ}C$ $T_{amb}=- 55^{\circ}C$	- -	400 220	$\Omega$
Low Level Input Voltage 1 (Noise Immunity) (Functional Test)	$V_{IL1}$	-	Verify Truth Table $V_{DD}=5V, V_{SS}=V_{EE}=0V$ Note 5	-	1.5	V
Low Level Input Voltage 2 (Noise Immunity) (Functional Test)	$V_{IL2}$	-	Verify Truth Table $V_{DD}=15V,$ $V_{SS}=V_{EE}= 0V$ Note 5	-	4	V
High Level Input Voltage 1 (Noise Immunity) (Functional Test)	$V_{IH1}$	-	Verify Truth Table $V_{DD}=5V, V_{SS}=V_{EE}=0V$ Note 5	3.5	-	V
High Level Input Voltage 2 (Noise Immunity) (Functional Test)	$V_{IH2}$	-	Verify Truth Table $V_{DD}=15V,$ $V_{SS}=V_{EE}= 0V$ Note 5	11	-	V
Threshold Voltage N-Channel	$V_{THN}$	-	INH Input and $V_{EE}$ Input at Ground All Other Inputs: $V_{IN}=5V$ $V_{DD}=5V, I_{SS}=-10\mu A$ $T_{amb}=+125^{\circ}C$ $T_{amb}=- 55^{\circ}C$	-0.3 -0.7	-3.5 -3.5	V

Characteristics	Symbols	MIL-STD-883 Test Method	Test Conditions Note 1	Limits		Units
				Min	Max	
Threshold Voltage P-Channel	$V_{THP}$	-	INH Input at Ground All Other Inputs: $V_{IN}=-5V$ $V_{SS}=V_{EE}=-5V,$ $I_{DD}=3.5\mu A$ $T_{amb}=+125^{\circ}C$ $T_{amb}=-55^{\circ}C$	0.3 0.7	3.5 3.5	V

2.3.3 Notes to Electrical Measurement Tables

1. Unless otherwise specified all inputs and channels shall be tested for each characteristic, inputs not under test shall be  $V_{IN} = V_{SS}$  or  $V_{DD}$  and channels not under test shall be open.
2. Functional tests shall be performed to verify Truth Table. The Maximum time to output comparator strobe = 300 $\mu$ s.
3. Quiescent Current shall be tested using the following input conditions where 1 =  $V_{IH}$  and 0 =  $V_{IL}$ :

TEST	INPUT CONDITIONS												
	INH	A	B	XCOM	XCH0	XCH1	XCH2	XCH3	YCOM	YCH0	YCH1	YCH2	YCH3
(a)	0	0	0	1	1	1	1	1	1	1	1	1	1
(b)	0	1	0	1	1	1	1	1	1	1	1	1	1
(c)	0	0	1	0	0	0	0	0	0	0	0	0	0
(d)	0	1	1	0	0	0	0	0	0	0	0	0	0
(e)	1	0	0	1	1	1	1	1	1	1	1	1	1

4. Channel ON Resistance shall be tested for each channel in both directions using the following input conditions:
  - (a)  $INH = V_{IL}$
  - (b) A, B =  $V_{IL}$  or  $V_{IH}$  per Truth Table to select channel under test.
  - (c)  $I_{IN}$  (CH or COM) = 100 $\mu$ A.
  - (d)  $R_{ON1}$  shall be tested with  $V_{IN}$  (CH or COM)= 1.5V, 1.9V, 2.3V, 2.7V, 3.3V, 3.7V, 4.1V.  
 $R_{ON2}$  shall be tested with  $V_{IN}$  (CH or COM)= 1.5V, 1.9V, 2.3V, 2.7V, 13.3V, 13.7V, 14.1V, 14.5V.  
 Channel ON Resistance shall be recorded for Channel Y0 (YCH0 to YCOM, YCOM to YCH0) at each specified  $V_{IN}$ . Other channels may be tested go-no-go.
5. Performed as a functional test to verify for all OFF channels  $I_{OFF}<2\mu A$  with  $V_{IN}$  (CH)= $V_{DD}$  through 1k $\Omega$ , COM output load resistance  $R_L=1k\Omega$ .
6. Input Clamp Voltage 2 to  $V_{DD}$ ,  $V_{IC2}$ , shall be tested on each input as follows:-

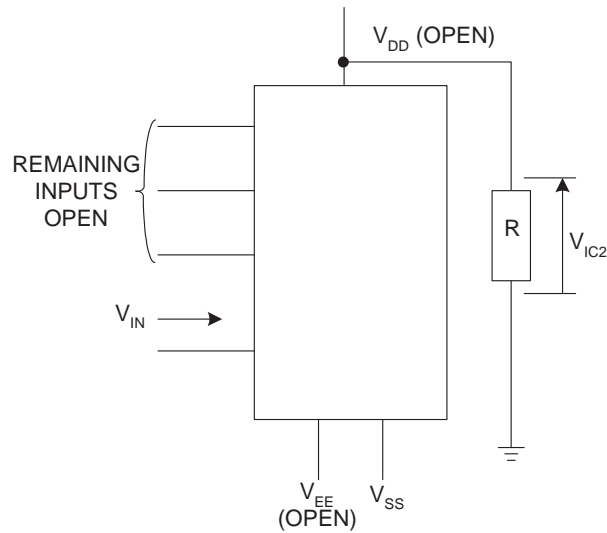

7. Guaranteed but not tested.
8. Read and record measurements shall be performed on a sample of 32 components with 0 failures permitted.

The pulse generator shall have the following characteristics:

$V_{GEN} = 0$  to  $V_{DD}$ ;  $f = 500\text{kHz}$ ;  $t_r$  and  $t_f \leq 15$  ns (10% to 90%); duty cycle = 50%. Output load capacitance  $C_L = 50\text{pF} \pm 5\%$  including scope probe, wiring and stray capacitance without component in the test fixture. Channel bias resistance  $R_L =$  as specified.

Propagation delay times shall be measured as follows:

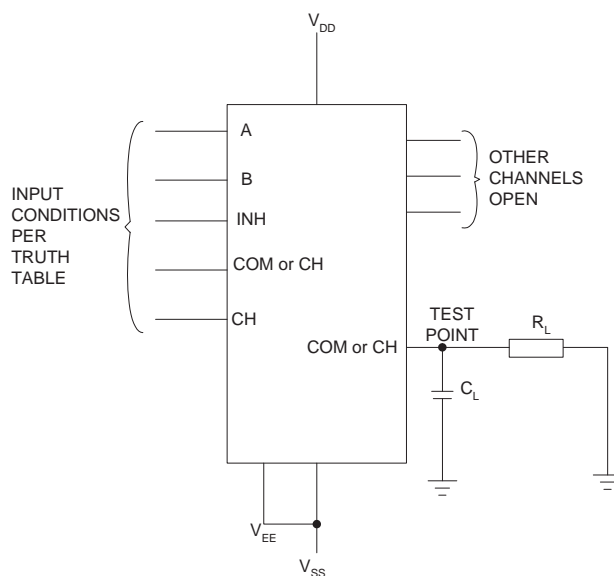

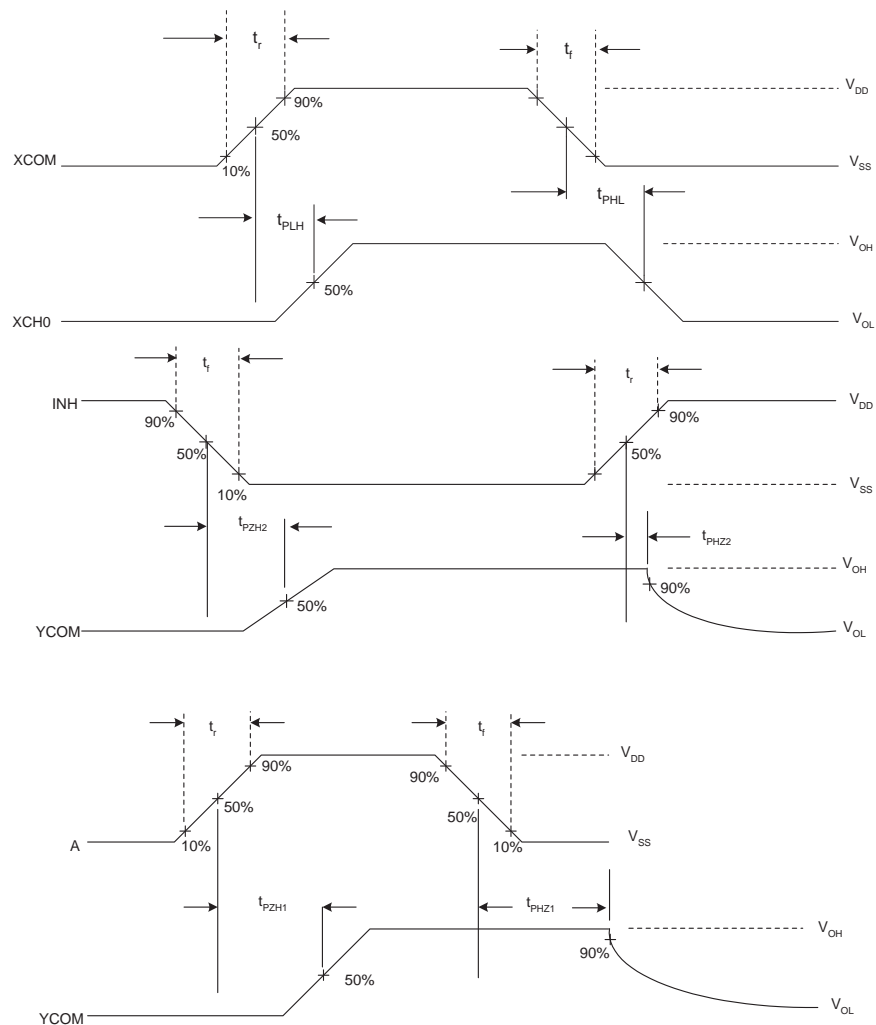

2.4

PARAMETER DRIFT VALUES

Unless otherwise specified, the measurements shall be performed at  $T_{amb} = +22 \pm 3^\circ\text{C}$ .

The test methods and test conditions shall be as per the corresponding test defined in Room Temperature Electrical Measurements.

The drift values ( $\Delta$ ) shall not be exceeded for each characteristic specified. The corresponding absolute limit values for each characteristic shall not be exceeded.



Characteristics	Symbols	Limits			Units
		Drift Value $\Delta$	Absolute		
			Min	Max	
Quiescent Current	$I_{DD}$	$\pm 0.15$	-	1	$\mu A$
Channel ON Resistance 1, YCH0 to YCOM, YCOM to YCH0 Note 2	$R_{ON1}$	$\pm 50$	-	1050	$\Omega$
Channel ON Resistance 2, YCH0 to YCOM, YCOM to YCH0 Note 2	$R_{ON2}$	$\pm 15$	-	280	$\Omega$
Threshold Voltage N-Channel	$V_{THN}$	$\pm 0.3$	-0.7	-3	V
Threshold Voltage P-Channel	$V_{THP}$	$\pm 0.3$	0.7	3	V

**NOTES:**

1. Unless otherwise specified all inputs and outputs shall be tested for each characteristic.
2. Channel ON Resistance shall be tested at each input voltage level specified in Room Temperature Electrical Measurements in both directions for YCH0 to YCOM only.

2.5

**INTERMEDIATE AND END-POINT ELECTRICAL MEASUREMENTS**

Unless otherwise specified, the measurements shall be performed at  $T_{amb} = +22 \pm 3^{\circ}C$ .

The test methods and test conditions shall be as per the corresponding test defined in Room Temperature Electrical Measurements .

The drift values ( $\Delta$ ) shall not be exceeded for each characteristic where specified. The corresponding absolute limit values for each characteristic shall not be exceeded.

Characteristics	Symbols	Limits			Units
		Drift Value $\Delta$	Absolute		
			Min	Max	
Functional Test 1	-	-	-	-	-
Quiescent Current	$I_{DD}$	$\pm 0.15$	-	1	$\mu A$
Low Level Input Current, Control Inputs	$I_{IL}$	-	-	-50	nA
High Level Input Current, Control Inputs	$I_{IH}$	-	-	50	nA
Channel OFF Leakage Current 1, Any Channel CH	$I_{OFF1}$	-	-	-100	nA
Channel OFF Leakage Current 3, All Channels Tested Together	$I_{OFF3}$	-	-	100	nA
Channel ON Resistance 1	$R_{ON1}$	$\pm 50$	-	1050	$\Omega$
Channel ON Resistance 2	$R_{ON2}$	$\pm 15$	-	280	$\Omega$
Low Level Input Voltage 1, (Noise Immunity) (Functional Test)	$V_{IL1}$	-	-	1.5	V
High Level Input Voltage 1, (Noise Immunity) (Functional Test)	$V_{IH1}$	-	3.5	-	V
Threshold Voltage N-Channel	$V_{THN}$	$\pm 0.3$	-0.7	-3	V
Threshold Voltage P-Channel	$V_{THP}$	$\pm 0.3$	0.7	3	V

**NOTES:**

1. Unless otherwise specified all inputs and outputs shall be tested for each characteristic.
2. The drift values ( $\Delta$ ) are applicable to the Operating Life test only.

2.6 HIGH TEMPERATURE REVERSE BIAS BURN-IN CONDITIONS

2.6.1 N-Channel HTRB

Characteristics	Symbols	Test Conditions	Units
Ambient Temperature	$T_{amb}$	+125 (+0 -5)	°C
Output COM (all Channels)	$V_{OUT}$	$V_{SS}$	V
Inputs CH (all Channels)	$V_{IN}$	$V_{DD}$	V
Inputs INH, A, B	$V_{IN}$	$V_{DD}$	V
Positive Supply Voltage	$V_{DD}$	15 (+0 -0.5)	V
Digital Negative Supply Voltage	$V_{SS}$	0	V
Analogue Negative Supply Voltage	$V_{EE}$	0	V
Duration	t	72	Hours

**NOTES:**

1. Input Protection Resistor = Output Load = 2kΩ min to 47kΩ max.

2.6.2 P-Channel HTRB

Characteristics	Symbols	Test Conditions	Units
Ambient Temperature	$T_{amb}$	+125 (+0 -5)	°C
Output COM (all Channels)	$V_{OUT}$	$V_{SS}$	V
Inputs CH (all Channels)	$V_{IN}$	$V_{SS}$	V
Inputs INH, A, B	$V_{IN}$	$V_{SS}$	V
Positive Supply Voltage	$V_{DD}$	15 (+0 -0.5)	V
Digital Negative Supply Voltage	$V_{SS}$	0	V
Analogue Negative Supply Voltage	$V_{EE}$	0	V
Duration	t	72	Hours

**NOTES:**

1. Input Protection Resistor = Output Load = 2kΩ min to 47kΩ max.

2.7 POWER BURN-IN CONDITIONS

Characteristics	Symbols	Test Conditions	Units
Ambient Temperature	$T_{amb}$	+125 (+0 -5)	°C
Output COM (all Channels)	$V_{OUT}$	$V_{SS}$	V
Inputs CH (all Channels)	$V_{IN}$	$V_{DD}$	V
Input A	$V_{IN}$	$V_{GEN1}$	V
Input B	$V_{IN}$	$V_{GEN2}$	V
Input INH	$V_{IN}$	$V_{GEN3}$	V
Pulse Voltage	$V_{GEN}$	0V to $V_{DD}$	V
Pulse Frequency Square Wave	$f_{GEN1}$ $f_{GEN2}$ $f_{GEN3}$	500k 250k 125k 50% Duty Cycle	Hz
Positive Supply Voltage	$V_{DD}$	15 (+0 -0.5)	V
Digital Negative Supply Voltage	$V_{SS}$	0	V
Analogue Negative Supply Voltage	$V_{EE}$	0	V

**NOTES:**

1. Input Protection Resistor = Output Load = 2kΩ min to 47kΩ max.

2.8 OPERATING LIFE CONDITIONS

The conditions shall be as specified for Power Burn-in.

**APPENDIX 'A'**

**AGREED DEVIATIONS FOR STMICROELECTRONICS (F)**

ITEMS AFFECTED	DESCRIPTION OF DEVIATIONS
Deviations from Screening Tests - Chart F3	<p>External Visual Inspection: The criteria applicable to chip outs are those described in MIL-STD-883, Test Method 2009, Paras 3.3.6(b) and 3.3.7(a).</p> <p>High Temperature Reverse Bias Burn-in: The temperature limits of MIL-STD-883, Para. 4.5.8(c) may be used.</p> <p>Power Burn-in test is performed using STMicroelectronics Specification Ref: 0019255.</p>
Deviations from Qualification and Periodic Tests - Chart F4	<p>External Visual Inspection: The criteria applicable to chip outs are those described in MIL-STD-883, Test Method 2009, Paras 3.3.6(b) and 3.3.7(a).</p> <p>Operating Life: The temperature limits of MIL-STD-883, Para. 4.5.8(c) may be used.</p>
Deviations from High and Low Temperatures Electrical Measurements	<p>High and Low Temperatures Electrical Measurements may be considered guaranteed but not tested if successful pilot lot testing has been performed on the wafer lot which includes High and Low Temperatures Electrical Measurements per the Detail Specification.</p> <p>A summary of the pilot lot testing shall be provided if required by the Purchase Order.</p>
Deviations from Room Temperature Electrical Measurements	<p>All AC characteristics (Capacitance and Timings) may be considered guaranteed but not tested if successful pilot lot testing has been performed on the wafer lot which includes AC characteristic measurements per the Detail Specification.</p> <p>A summary of the pilot lot testing shall be provided if required by the Purchase Order.</p>