



Pages 1 to 41

**SWITCHES, THERMOSTATIC, BIMETALLIC,
HERMETICALLY SEALED**

ESCC Generic Specification No. 3702

ISSUE 2
August 2005



Document Custodian: European Space Agency - see <https://escies.org>

	ESCC Generic Specification No. 3702		PAGE i ISSUE 2
---	--	--	-------------------

LEGAL DISCLAIMER AND COPYRIGHT

European Space Agency, Copyright © 2005. All rights reserved.

The European Space Agency disclaims any liability or responsibility, to any person or entity, with respect to any loss or damage caused, or alleged to be caused, directly or indirectly by the use and application of this ESCC publication.

This publication, without the prior permission of the European Space Agency and provided that it is not used for a commercial purpose, may be:

- copied in whole in any medium without alteration or modification.
- copied in part, in any medium, provided that the ESCC document identification, comprising the ESCC symbol, document number and document issue, is removed.



DOCUMENTATION CHANGE NOTICE

(Refer to <https://escies.org> for ESCC DCR content)

DCR No.	CHANGE DESCRIPTION
153, 156	Specification upissued to incorporate policy, technical and editorial changes per DCR.

	<p style="text-align: center;">ESCC Generic Specification No. 3702</p>		<p>PAGE 3 ISSUE 2</p>
---	--	--	---------------------------

TABLE OF CONTENTS

		<u>Page</u>
1.	<u>INTRODUCTION</u>	7
1.1	Scope	7
1.2	Applicability	7
2.	<u>APPLICABLE DOCUMENTS</u>	7
2.1	ESCC Specifications	7
2.2	Other (Reference) Documents	7
2.3	Order of Precedence	8
3.	<u>TERMS, DEFINITIONS, ABBREVIATIONS, SYMBOLS AND UNITS</u>	8
4.	<u>REQUIREMENTS</u>	8
4.1	General	8
4.1.1	Specifications	8
4.1.2	Conditions and Methods of Test	8
4.1.3	Manufacturer's Responsibility for Performance of Tests and Inspections	8
4.1.4	Inspection Rights	9
4.1.5	Pre-encapsulation Inspection	9
4.2	Qualification Approval Requirements on a Manufacturer	9
4.3	Deliverable Components	9
4.3.1	Lot Failure	9
4.3.2	Testing and Lot Acceptance Levels	10
4.4	Marking	10
4.5	Materials and Finishes	10
5.	<u>PRODUCTION CONTROL</u>	10
5.1	General	10
5.2	Special In-process Controls	10
6.	<u>FINAL PRODUCTION TESTS</u>	12
6.1	General	12
6.2	Test Methods and Conditions	12
6.3	Documentation	12
7.	<u>RUN-IN AND ELECTRICAL MEASUREMENTS</u>	12
7.1	General	12
7.1.1	Conditions of Test	12
7.1.2	Data Points	12
7.2	Failure Criteria	12
7.2.1	Parameter Drift Failure	12
7.2.2	Parameter Limit Failure	13
7.2.3	Other Failures	13
7.3	Failed Components	13
7.4	Lot Failure	13
7.4.1	Lot Failure during 100% Testing	13
7.4.2	Lot Failure during Sample Testing	13
7.5	Documentation	13

	<u>Page</u>
8. <u>QUALIFICATION APPROVAL AND LOT ACCEPTANCE TESTS</u>	14
8.1 Qualification Testing	14
8.1.1 General	14
8.1.2 Distribution within the Qualification Test Lot	14
8.2 Lot Acceptance Testing	14
8.2.1 General	14
8.2.2 Distribution within the Sample for Lot Acceptance Testing	14
8.2.3 Lot Acceptance Level 3 Testing	15
8.2.4 Lot Acceptance Level 2 Testing	15
8.2.5 Lot Acceptance Level 1 Testing	15
8.3 Failure Criteria	15
8.3.1 Environmental and Mechanical Test Failures	15
8.3.2 Electrical Failures	16
8.3.3 Other Failures	16
8.4 Failed Components	16
8.5 Lot Failure	16
8.6 Documentation	16
9. <u>TEST METHODS AND PROCEDURES</u>	21
9.1 Internal Visual Inspection	21
9.2 Seal Test	21
9.3 External Visual Inspection	21
9.4 Dimension Check	21
9.5 Electrical and Thermal Measurements	21
9.5.1 General	21
9.5.2 Parameter Drift Value Measurements	24
9.5.3 Electrical Measurements at High and Low Temperatures	24
9.5.4 Electrical and Thermal Measurements	24
9.5.5 Electrical and Thermal Measurements during Endurance Testing	24
9.6 Creepage	24
9.6.1 Test Equipment	25
9.6.2 Requirements	25
9.7 Run-in	26
9.8 Response Time	27
9.9 Rapid Change of Temperature	29
9.9.1 Initial Measurements	29
9.9.2 Procedure and Recovery	29
9.9.3 Final Measurements	29
9.10 Vibration	29
9.10.1 Initial Measurements	29
9.10.2 Procedure	29
9.10.3 Conditions	29
9.10.4 Final Measurements	29
9.11 Shock	30
9.11.1 Initial Measurements	30
9.11.2 Procedure	30
9.11.3 Conditions	30
9.11.4 Final Measurements	30
9.12 Robustness of Terminations	30
9.12.1 Initial Measurements	30
9.12.2 Procedure	30
9.12.3 Visual Examination	31



	<u>Page</u>	
9.13	Permanence of Marking	31
9.14	Resistance to Soldering Heat	31
9.14.1	Initial Measurements	31
9.14.2	Procedure and Recovery	31
9.14.3	Final Measurements	31
9.15	Damp Heat (Steady State)	31
9.16	Overload	31
9.16.1	Procedure	31
9.16.2	Final Measurements	32
9.17	Operating Life	32
9.17.1	Duration	32
9.17.2	Method of Mounting	32
9.17.3	Test Conditions	32
9.17.4	Intermediate and End Data Points	32
9.17.5	Visual Examination	32
9.18.	Solderability	32
9.18.1	Procedure	32
9.18.2	Visual Examination	32
9.19	High Temperature Storage	33
9.19.1	Duration	33
9.19.2	Method of Mounting	33
9.19.3	Test Conditions and Recovery	33
9.19.4	End Data Points	33
9.20	Low Temperature Storage	33
9.20.1	Test conditions	33
9.21	Salt Mist	33
9.21.1	Method of Mounting	33
9.21.2	Duration	33
9.21.3	Visual Examination	33
9.22	Encapsulation	33
10.	<u>DATA DOCUMENTATION</u>	34
10.1	General	34
10.1.1	Qualification Approval	34
10.1.2	Testing Level "B"	34
10.1.3	Testing Level "C"	35
10.1.4	Data Retention/Data Access	35
10.2	Cover Sheet(s)	35
10.3	List of Equipment Used	36
10.4	List of Test References	36
10.5	Special In-process Control Data	36
10.6	Final Production Test Data	36
10.7	Run-in and Electrical Measurement Data	36
10.7.1	Testing Level "B"	36
10.7.2	Testing Level "C"	36
10.8	Qualification Test Data	37
10.9	Lot Acceptance Test Data	37
10.9.1	Testing Level "B"	37
10.9.2	Testing Level "C"	37
10.10	Failed Components List and Failure Analysis Report	37
10.11	Certificate of Conformity	37

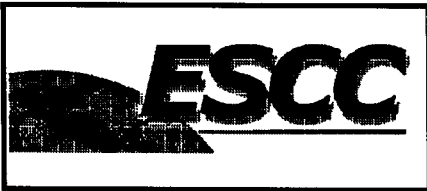

11.	<u>DELIVERY</u>	<u>Page</u> 38
12.	<u>PACKAGING AND DESPATCH</u>	38
<u>CHARTS</u>		
I	TESTING LEVELS	11
II	FINAL PRODUCTION TESTS	17
III	RUN-IN AND ELECTRICAL MEASUREMENTS	18
IV	QUALIFICATION TESTS	19
V	LOT ACCEPTANCE TESTS	20
<u>FIGURES</u>		
I	THERMAL DIAGRAM FOR THERMAL TEST	24
II	THERMAL DIAGRAM FOR CREEPAGE TEST	25
III	THERMAL DIAGRAM FOR RUN-IN TEST	26
IV	THERMAL DIAGRAM FOR RESPONSE TIME TEST	28
<u>ANNEXES</u>		
I	LTPD SAMPLING PLAN FOR LOT SIZES GREATER THAN 200 DEVICES	39
	LTPD SAMPLING PLAN FOR LOT SIZES LESS THAN, OR EQUAL TO, 200 DEVICES	40

	<p style="text-align: center;">ESCC Generic Specification No. 3702</p>		<p>PAGE 7 ISSUE 2</p>
--	--	--	---------------------------

1. INTRODUCTION

1.1 SCOPE

This specification defines the general requirements for the qualification approval, procurement, including lot acceptance testing, and delivery of Switches, Thermostatic, Bimetallic, Hermetically Sealed, for space application.

This specification contains the appropriate inspection and test schedules and also specifies the data documentation requirements.

1.2 APPLICABILITY

This specification is primarily applicable to the granting of qualification approval to a component in accordance with ESCC Basic Specification No. 20100 and the procurement of such components from qualified Manufacturers.

2. APPLICABLE DOCUMENTS

The following documents form part of, and shall be read in conjunction with, this specification. The relevant issues shall be those in effect on the date of placing the purchase order.

2.1 ESCC SPECIFICATIONS

No. 20100, Requirements for the Qualification of Standard Electronic Components for Space Application.

No. 20400, Internal Visual Inspection.

No. 20500, External Visual Inspection.

No. 20600, Preservation, Packaging and Despatch of ESCC Electronic Components.

No. 20900, Radiographic Inspection.

No. 21300, Terms, Definitions, Abbreviations, Symbols and Units.

No. 21700, General Requirements for the Marking of ESCC Components.

No. 22800, ESCC Non-conformance Control System.

No. 23500, Lead Materials and Finishes for Components for Space Application.

No. 24600, Minimum Quality System Requirements.

No. 24800, Resistance to Solvents of Marking, Materials and Finishes.

With the exception of ESCC Basic Specifications No. 20100, 21700, 22800 and 24600, where Manufacturers' specifications are equivalent to, or more stringent than, the ESCC Basic Specifications listed above, they may be used in place of the latter, subject to the approval of the appropriate Qualifying Space Agency.

Such replacements shall be clearly identified in the applicable Process Identification Document (P.I.D.) and listed in an appendix to the appropriate Detail Specification.

Unless otherwise stated herein, references within the text of this specification to "the Detail Specification" shall mean the relevant ESCC Detail Specification.

2.2 OTHER (REFERENCE) DOCUMENTS

IEC Publication No. 68, Basic Environmental Testing Procedures.

IEC Publication No. 389.1, Thermostatic Switches, Part I General Requirements and Measuring Methods.

	<p style="text-align: center;">ESCC Generic Specification No. 3702</p>	<p>PAGE 8 ISSUE 2</p>
--	--	---------------------------

IEC Publication No. 410. Sampling Plans and Procedures for Inspection by Attributes or, MIL-STD-105, Sampling Procedures and Tables for Inspection by Attributes. MIL-STD-414, Sampling Procedures and Tables for Inspection by Variables for Percent Defective. ESA PSS-01-702, A Thermal Vacuum Test for the Screening of Space Materials.

2.3 **ORDER OF PRECEDENCE**

For the purpose of interpretation and in case of conflict with regard to documentation, the following order of precedence shall apply:-

- (a) ESCC Detail Specification.
- (b) ESCC Generic Specification.
- (c) ESCC Basic Specification.
- (d) Other documents, if referenced herein.

3. **TERMS, DEFINITIONS, ABBREVIATIONS, SYMBOLS AND UNITS**

The terms, definitions, abbreviations, symbols and units specified in ESCC Basic Specification No. 21300 and IEC Publication 389.1 Part I, Chapter 1, Para. 3 shall apply.

4. **REQUIREMENTS**

4.1 **GENERAL**

The test requirements for qualification approval of a component shall comprise final production tests (see Chart II), run-in and electrical measurements to testing level "B" (see Chart III) and qualification testing (see Chart IV).

The test requirements for procurement of components shall comprise final production tests (Chart II), run-in and electrical measurements to testing level "B" or "C" as required (Chart III) together with, when applicable, a level of lot acceptance testing (see Chart V) to be specified by the Orderer.

If a Manufacturer elects to eliminate a final production test by substituting an in-process control or statistical process control procedure, the Manufacturer is still responsible for delivering components that meet all of the performance, quality and reliability requirements defined in this specification and the Detail Specification.

4.1.1 **Specifications**

For qualification approval, procurement (including lot acceptance testing) and delivery of components in conformity with this specification, the specifications listed in Section 2 of this document shall apply in total unless otherwise specified herein or in the Detail Specification.

4.1.2 **Conditions and Methods of Test**

The conditions and methods of test shall be in accordance with this specification, the ESCC Basic Specifications referenced herein and the Detail Specification.

4.1.3 **Manufacturer's Responsibility for Performance of Tests and Inspections**

The Manufacturer shall be responsible for the performance of tests and inspections required by the applicable specifications. These tests and inspections shall be performed at the plant of the Manufacturer of the components unless it is agreed by the Qualifying Space Agency prior to commencing qualification testing, or procurement, to use an approved external facility.

	<p style="text-align: center;">ESCC Generic Specification No. 3702</p>		<p>PAGE 9 ISSUE 2</p>
---	--	--	---------------------------

4.1.4 Inspection Rights

The Qualifying Space Agency (for qualification approval or for a procurement) reserves the right to monitor any of the tests and inspections scheduled in the applicable specifications.

4.1.5 Pre-encapsulation Inspection

The Manufacturer shall notify the Orderer at least 2 working weeks before the commencement of pre-encapsulation inspection.

The Orderer shall indicate immediately whether or not he intends to witness the inspection.

4.2 QUALIFICATION APPROVAL REQUIREMENTS ON A MANUFACTURER

To obtain and maintain the qualification approval of a component or family of components, a Manufacturer shall satisfy the requirements of ESCC Basic Specification No. 20100.

4.3 DELIVERABLE COMPONENTS

Components delivered to this specification shall be processed and inspected in accordance with the relevant Process Identification Document (P.I.D.). Each delivered component shall be traceable to its production lot. Components delivered to this specification shall have completed satisfactorily all tests to the testing level and lot acceptance level specified in the purchase order (see Para. 4.3.2).

ESCC qualified components delivered to this specification shall be produced from lots that are capable of passing all tests, and sequences of tests, that are defined in Charts IV and V. The Manufacturer shall not knowingly supply components that cannot meet this requirement. In the event that, subsequent to delivery and prior to operational use, a component is found to be in a condition such that it could not have passed these tests at the time of manufacture, this shall be grounds for rejection of the delivered lot.

Components failing inspections and tests of the higher testing level (i.e level 'B') shall not be supplied against any order for components of the lower testing level.

4.3.1 Lot Failure

Lot failure may occur during final production tests (Chart II), run-in and electrical measurements (Chart III), qualification testing (Chart IV) or lot acceptance testing (Chart V).

Should such failure occur, the non-conformance procedure shall be initiated in accordance with ESCC Basic Specification No. 22800.

Should such failure occur during procurement, the Manufacturer shall notify the Orderer by telex within 2 working days, giving details of the number and mode of failure and the suspected cause.

In the case where qualification approval has been granted to the component, he shall, at the same time by the same means, inform the Qualifying Space Agency in order that the latter may consider its implications.

No further testing shall be performed on the failed components except on instruction from the Orderer. The Orderer shall inform the Manufacturer and the Qualifying Space Agency within 2 working days of receipt of the telex, by the same means, what action shall be taken.

In the case when lot failure occurs during qualification testing, the Manufacturer shall immediately notify the appropriate Qualifying Space Agency who will define a course of action to be followed. No further testing shall be performed on the failed components.

	<p style="text-align: center;">ESCC Generic Specification No. 3702</p>		<p>PAGE 10 ISSUE 2</p>
---	--	--	----------------------------

4.3.2 Testing and Lot Acceptance Levels

This specification defines 2 levels of testing severity which are designated by the letters "B" and "C" (see Chart I) and 3 levels of lot acceptance testing (see Chart V).

The lot acceptance levels are designated 1, 2 and 3 and are comprised of tests as follows:-

Level 3 (LA3) - Electrical Subgroup.

Level 2 (LA2) - Endurance Subgroup.
plus Electrical Subgroup.

Level 1 (LA1) - Environmental and Mechanical Subgroup.
plus Endurance Subgroup.
plus Electrical Subgroup.

The required testing level and lot acceptance level shall both be specified in a purchase order.

4.4 MARKING

All components procured and delivered to this specification from a source qualified according to ESCC Basic Specification No. 20100 shall be marked in accordance with ESCC Basic Specification No. 21700. Thus, they shall bear the ESA symbol to signify their conformance to the ESCC qualification approval requirements and full compliance with the requirements of this specification and the Detail Specification.

Components procured from sources which are not ESCC qualified, provided that they fully comply with the Procurement requirements of this specification and the Detail Specification, may bear the ESCC marking **with the exception of the ESA symbol.**

4.5 MATERIALS AND FINISHES

All non-metallic materials and finishes, that are not within a hermetically sealed enclosure, of the components specified herein shall meet the outgassing requirements as outlined in ESA PSS-01-702.

Specific requirements for materials and finishes are specified in the Detail Specification.

5. PRODUCTION CONTROL

5.1 GENERAL

The minimum requirements for production control, which are equally applicable to procurement, are defined in ESCC Basic Specification No. 20100, Para.'s 5.1 and 5.2.

5.2 SPECIAL IN-PROCESS CONTROLS

Where applicable, special in-process controls shall apply as specified in the Detail Specification.

CHART I - TESTING LEVELS

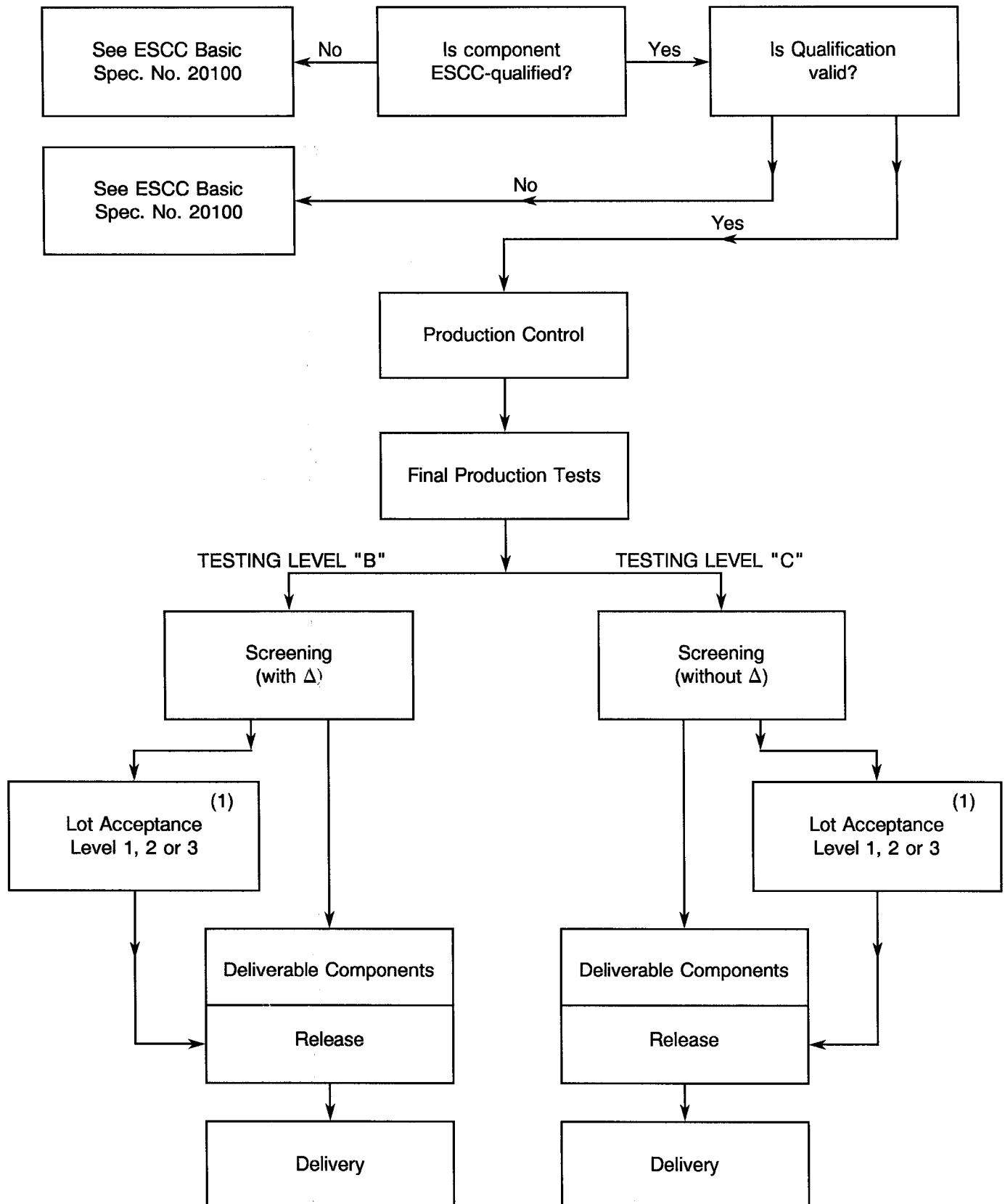

NOTES

1. When applicable.



6. FINAL PRODUCTION TESTS

6.1 GENERAL

Unless otherwise specified in the Detail Specification, all components used for qualification testing and all components for delivery, including those submitted to lot acceptance tests, shall be subjected to tests and inspections in accordance with Chart II.

Unless otherwise specified in the Detail Specification, the tests shall be performed in the order shown.

Any components that do not meet these requirements shall be removed from the lot and at no future time be resubmitted to the requirements of this specification.

6.2 TEST METHODS AND CONDITIONS

The applicable test methods and conditions are specified in the paragraphs referenced in Chart II of this specification.

6.3 DOCUMENTATION

Documentation of final production test data shall be in accordance with the requirements of Para. 10.6 of this specification.

7. RUN-IN AND ELECTRICAL MEASUREMENTS

7.1 GENERAL

Unless otherwise specified in the Detail Specification, all components used for qualification testing and all components for delivery, including those submitted to lot acceptance tests, shall be subjected to tests and inspections in accordance with Chart III.

Unless otherwise specified in the Detail Specification, the tests shall be performed in the order shown.

The applicable test methods and conditions are specified in the paragraphs referenced in Chart III.

7.1.1 Conditions of Test

The conditions for run-in shall be as shown in Table 5 of the Detail Specification.

Unless otherwise specified in the Detail Specification, components of both Levels "B" and "C" shall be subjected to a total run-in of 500 cycles. For the applicable test methods and procedures, see Para. 9.7.

7.1.2 Data Points

For components of testing level 'B' undergoing a total run-in of 500 cycles, the data points for parameter drift measurement shall be 0 cycles (initial) and 500 cycles (final).

7.2. FAILURE CRITERIA

7.2.1 Parameter Drift Failure

The acceptable delta limits are shown in Table 4 of the Detail Specification. A component of testing level 'B' shall be counted as a parameter drift failure if the changes during run-in are larger than the delta (Δ) values specified.

	<p style="text-align: center;">ESCC Generic Specification No. 3702</p>	<p>PAGE 13 ISSUE 2</p>
---	--	----------------------------

7.2.2 Parameter Limit Failure

A component shall be counted as a limit failure if one or more parameters exceed the limits shown in Tables 2 or 3 of the Detail Specification.

Any component which exhibits a limit failure prior to the run-in sequence shall be rejected and not counted when determining lot rejection.

7.2.3 Other Failures

A component shall be counted as a failure in any of the following cases:

- Mechanical failure.
- Handling failure.
- Lost component.

7.3 FAILED COMPONENTS

A component shall be considered as a failed component if it exhibits one or more of the failure modes described in Para. 7.2 of this specification.

7.4 LOT FAILURE

In case of lot failure, the Manufacturer shall act in accordance with the requirements of Para. 4.3.1 of this specification.

7.4.1 Lot Failure during 100% Testing

If the number of components failed on the basis of the failure criteria described in Para. 7.2 exceeds 10% (rounded upwards to the nearest whole number) of the number of components submitted to run-in and electrical measurements, the lot shall be considered as failed.

If a lot is composed of groups of components of one family defined in one ESCC Detail Specification, but separately identifiable for any reason, then the lot failure criteria shall apply separately to each identifiable group.

7.4.2 Lot Failure during Sample Testing

A lot shall be considered as failed if the number of allowable failures during sample testing, in accordance with General Inspection Level II of IEC Publication No. 410 or MIL-STD-105 and the applicable AQL as specified in the Detail Specification, is exceeded.

In the case where an LTPD to MIL-STD-414 is specified in the Detail Specification, a lot shall be considered as failed if the number of failures allowed is exceeded (see Annex I for LTPD Sampling Plan).

If a lot failure occurs in either case, a 100% testing may be performed with the lot failure criteria given in Para. 7.4.1.

7.5 DOCUMENTATION

Data documentation of run-in and electrical measurements shall be in accordance with Para. 10.7 of this specification.

8. QUALIFICATION APPROVAL AND LOT ACCEPTANCE TESTS

8.1 QUALIFICATION TESTING

8.1.1 General

Qualification testing shall be in accordance with the requirements of Chart IV of this specification. The tests to Chart IV shall be performed on the specified sample, chosen at random from components which have successfully passed the tests in Charts II and III for Testing Level "B". This sample constitutes the qualification test lot.

The qualification test lot is divided into subgroups of tests and all components assigned to a subgroup shall be subjected to all of the tests in that subgroup, in the sequence shown.

The applicable test requirements are detailed in the paragraphs referenced in Chart IV.

The conditions governing qualification testing are given in ESCC Basic Specification No. 20100, Para. 5.3 and, for the extension or renewal of qualification approval, in Paras. 6.3 and 6.4.

8.1.2 Distribution within the Qualification Test Lot

A minimum sample of 36 Grade 1 components (see Table 1(a) of the Detail Specification) shall be submitted to qualification test. The distribution within the sample shall be as follows:

- 1/3 of the lot with the lowest TNf temperature.
- 1/3 of the lot with the mid-range TNf temperature.
- 1/3 of the lot with the highest TNf temperature.

Samples with the lowest and highest TNf temperature shall have the narrowest temperature differential (TNf-TNr) as defined in the Detail Specification.

8.2 LOT ACCEPTANCE TESTING

8.2.1 General

The sample sizes of the 3 lot acceptance levels are specified in Chart V. All components assigned to a subgroup shall be subjected to all of the tests of that subgroup in the sequence shown.

The tests to Chart V shall be performed on the specified sample which shall have been chosen, whenever possible, at random from the proposed delivery lot (but see Para. 8.2.3(b)). The applicable test requirements are detailed in the paragraphs referenced in Chart V.

As a minimum for procurement of non-qualified components, lot acceptance level 3 tests shall apply. For procurement of qualified components, lot acceptance testing shall be performed if specified in a purchase order. Procurement lots ordered with a lot acceptance test level shall be delivered only after successful completion of lot acceptance testing.

8.2.2 Distribution within the Sample for Lot Acceptance Testing

Where a Detail Specification covers a range or series of components that are considered similar, then it may be necessary that the sample for lot acceptance testing be comprised of component types so selected that they adequately represent all of the various mechanical, structural and electrical peculiarities of the procured range or series.

The distribution of the component types will normally vary from procurement to procurement and shall be as specified by the Orderer, following as closely as possible the requirements prescribed in Para. 8.1.2. of this specification.

	<p style="text-align: center;">ESCC Generic Specification No. 3702</p>	<p style="text-align: right;">PAGE 15 ISSUE 2</p>
---	--	---

8.2.3 Lot Acceptance Level 3 Testing (LA3)

Lot acceptance level 3 tests are designated as the electrical subgroup and comprise electrical measurements of characteristics and tests to prove the assembly capability of the component. For LA3 testing, the following requirements and conditions shall apply:-

- (a) LA3 testing shall be performed by the Manufacturer's quality assurance personnel using dedicated quality assurance equipment whenever possible. LA3 testing shall not be a repetition of routine measurements made by production personnel during final production tests and run-in and electrical measurements.
- (b) When tests to Tables 2 and 3 of the Detail Specification have been performed on a sample basis, then the components for LA3 testing shall be selected from this sample.
- (c) The electrical measurements for LA3 are considered to be non-destructive and therefore components so tested may form part of the delivery lot.
- (d) The solderability and robustness of terminations tests are considered to be destructive and therefore components so tested shall not form part of the delivery lot. Post-run-in electrical rejects may be used for these tests.
- (e) When required in the purchase order, the Manufacturer shall notify the Orderer at least 2 working weeks before the commencement of LA3 testing. The Orderer shall indicate immediately whether or not he intends to witness the tests.

8.2.4 Lot Acceptance Level 2 Testing (LA2)

Lot acceptance level 2 testing shall comprise the tests for LA3 (electrical subgroup) plus tests on an endurance subgroup. For the electrical subgroup, the requirements and conditions as for LA3 (see Para. 8.2.3) shall apply.

For the endurance subgroup, the following shall apply:-

- (a) Components of testing level "C", selected for the endurance subgroup, shall be serialised prior to the tests.
- (b) The tests in this subgroup are considered to be destructive and therefore components (of testing level "B" or "C") so tested shall not form part of the delivery lot.

8.2.5 Lot Acceptance Level 1 Testing (LA1)

Lot acceptance level 1 testing shall comprise the tests for LA3 (electrical subgroup) and LA2 (endurance subgroup) plus tests on an environmental and mechanical subgroup. For the electrical and endurance subgroups, the requirements and conditions for LA3 (see Para. 8.2.3) and LA2 (see Para. 8.2.4) respectively shall apply.

For the environmental subgroup, the following shall apply:-

- (a) Components of testing level "C", selected for the environmental subgroup, shall be serialised prior to the tests.
- (b) The tests in this subgroup are considered to be destructive and therefore components (of testing level "B" or "C") so tested shall not form part of the delivery lot.

8.3 FAILURE CRITERIA

The following criteria shall apply to qualification testing and to lot acceptance testing.

8.3.1 Environmental and Mechanical Test Failures

The following shall be counted as component failures:

- Components which fail during tests for which the pass/fail criteria are inherent in the test method e.g. solderability, robustness of terminations, etc.

8.3.2 Electrical Failures

The following shall be counted as component failures:-

- (a) Components which, when subjected to electrical measurements on completion of environmental tests, in accordance with either Table 2 or Table 6, as specified in the Detail Specification, fail one or more of the applicable limits.
- (b) Components which, when subjected to electrical measurements at intermediate and end-points during endurance testing, in accordance with Table 6 of the Detail Specification, fail one or more of the applicable limits.
- (c) Components which, when subjected to measurement of electrical characteristics, in accordance with Tables 2 and 3 of the Detail Specification, fail one or more of the applicable limits.

8.3.3 Other Failures

The following additional failures may also occur during qualification testing or lot acceptance testing:-

- (a) Components failing to comply with the requirements of ESCC Basic Specification No. 20500.
- (b) Lost components.

8.4 FAILED COMPONENTS

A component shall be considered as failed if it exhibits one or more of the failure modes detailed in Para. 8.3 of this specification. The allowable number of failed components per Subgroup, the aggregate failure constraints and the permitted distribution of such failures are shown at the foot of Charts IV and V of this specification.

When requested by the Qualifying Space Agency or the Orderer, failure analysis of failed components shall be performed by the Manufacturer and the results provided.

Failed components from successful lots shall be marked as such and be stored at the Manufacturer's plant for 24 months.

8.5 LOT FAILURE

A lot shall be considered as failed if the allowable number of failures according to Chart IV or V of this specification, as relevant, has been exceeded.

In the case of lot failure, the Manufacturer shall act in accordance with Para. 4.3.1 of this specification.

8.6 DOCUMENTATION

For qualification testing, the qualification test data shall be documented in accordance with the requirements of Para. 10.8 of this specification.

In the case of lot acceptance testing, the data shall be documented in accordance with the requirements of Para. 10.9 of this specification.

CHART II - FINAL PRODUCTION TESTS

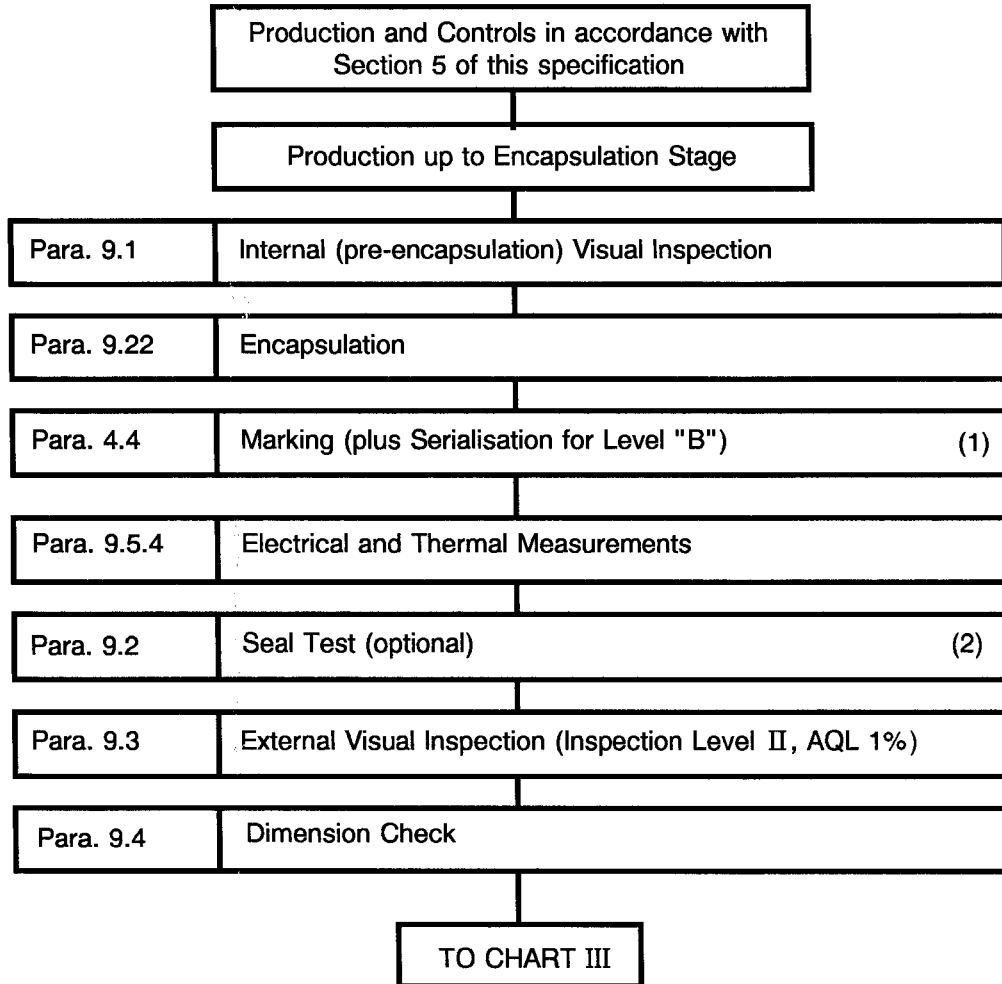

NOTES

1. Marking and serialisation may take place at a different stage of the sequence.
2. The performance of this test is left to the Manufacturer's discretion.

CHART III - RUN-IN AND ELECTRICAL MEASUREMENTS

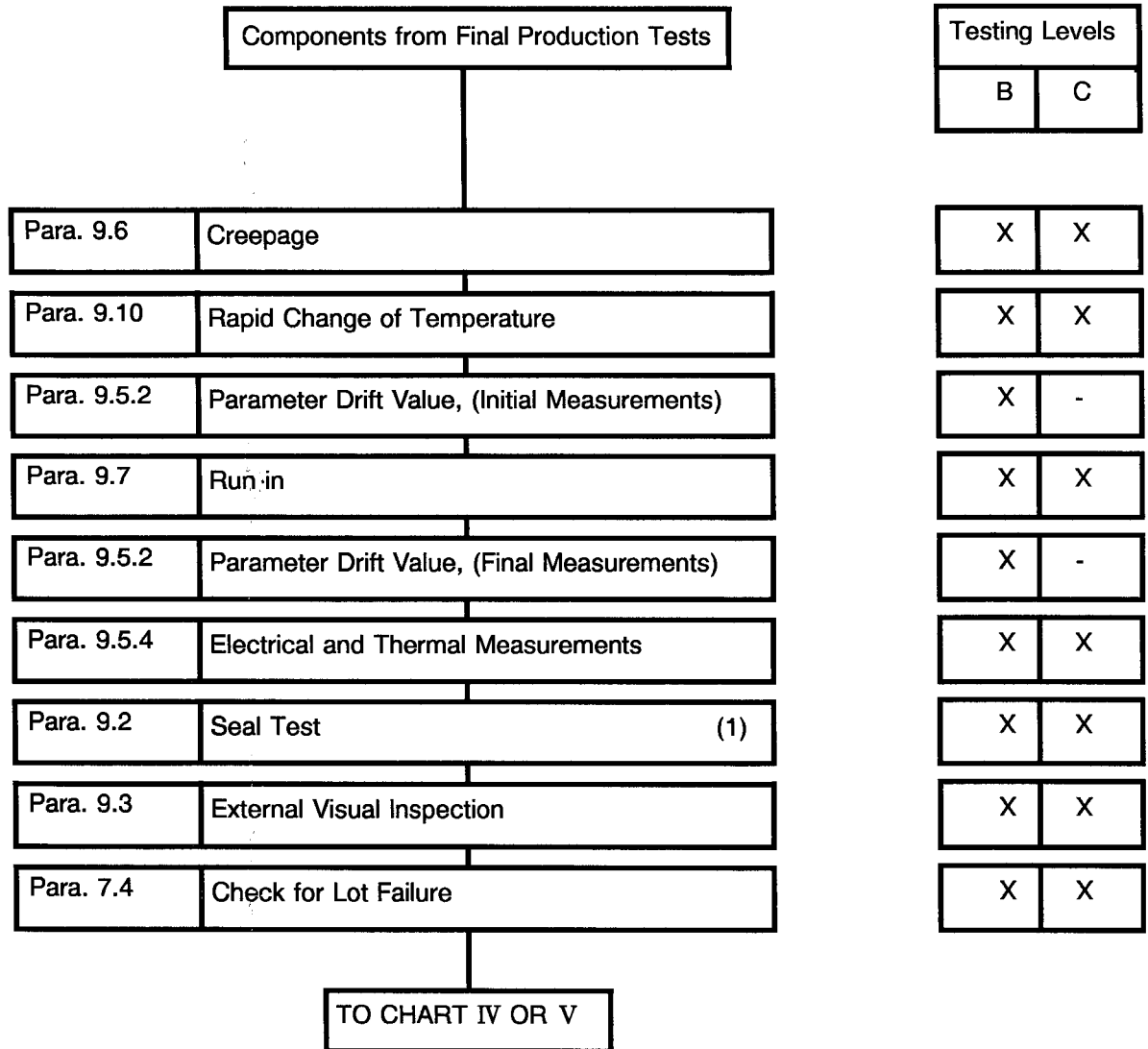

NOTES

1. Seal Test rejects not to be counted for lot failure.

CHART IV - QUALIFICATION TESTS

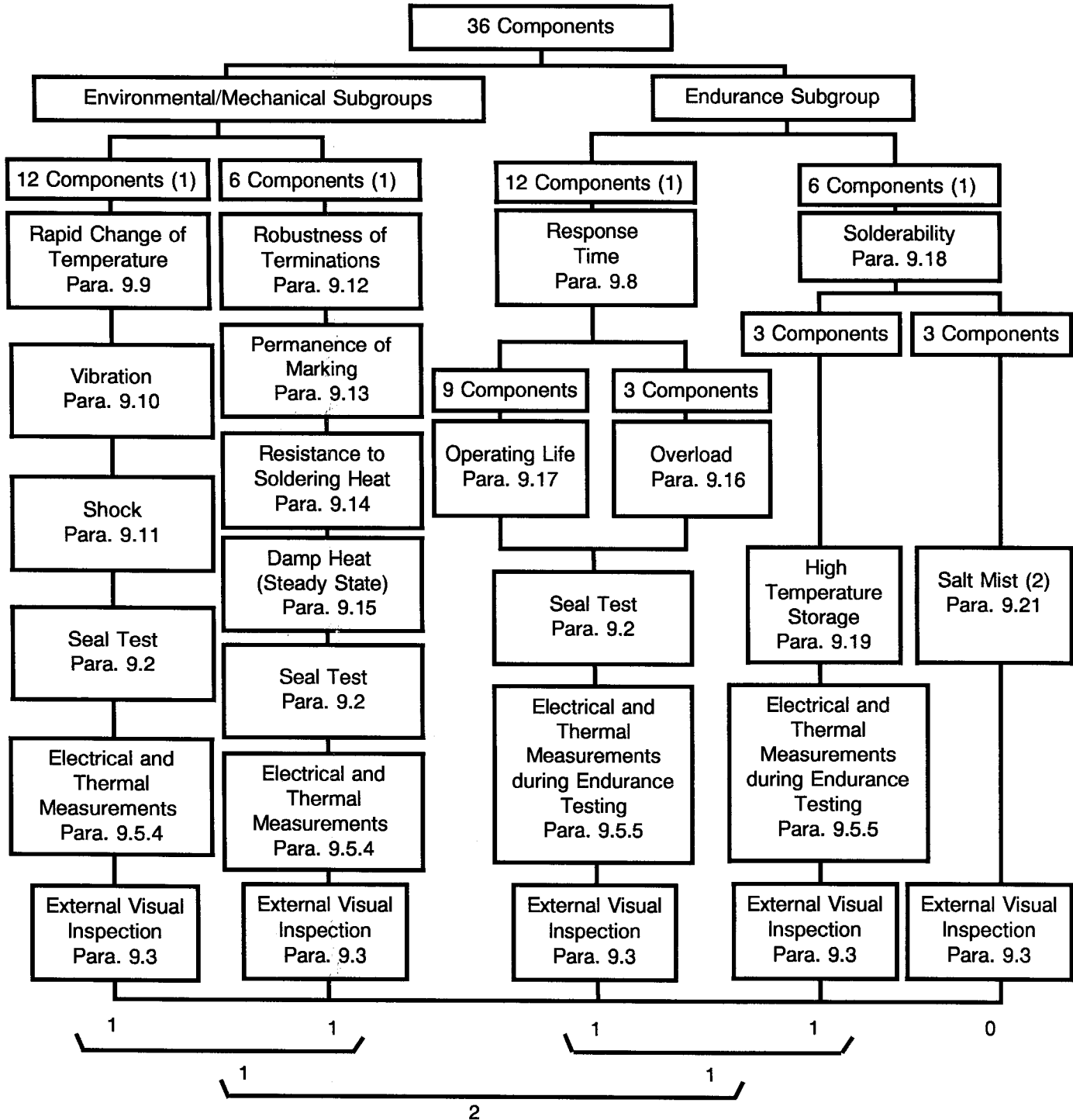

Allowable number of failed components: 2

NOTES

1. For distribution within the subgroups, see Para. 8.1.2.
2. Need not be repeated if performed during Evaluation Testing.

CHART V - LOT ACCEPTANCE TESTS

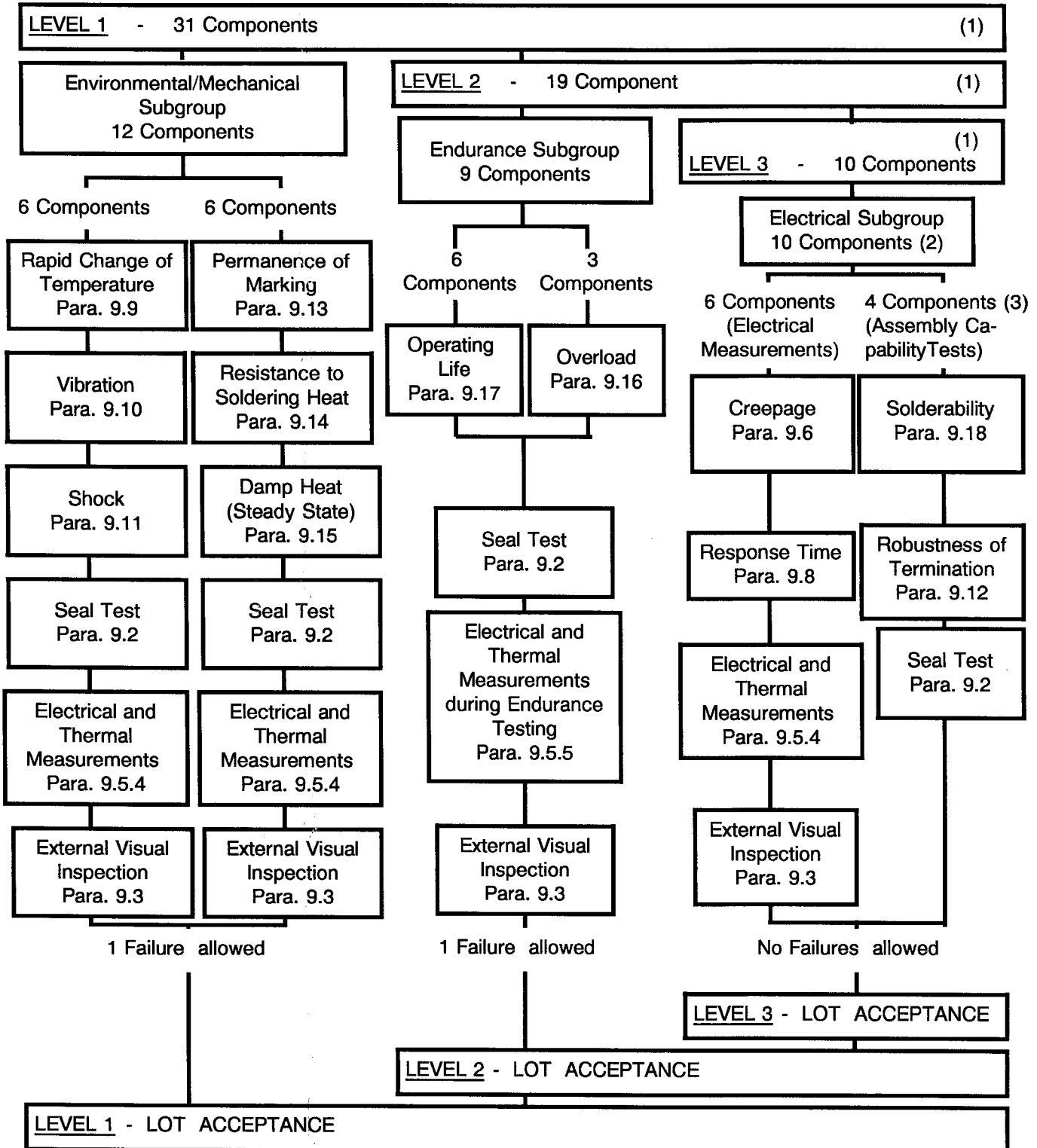

NOTES

1. For distribution within the subgroups, see Para. 8.2.2.
2. Including 6 deliverable items. Level 3 (Electrical Measurements) contains non-destructive tests only and the components submitted to it can be deliverable items from the procurement lot.
3. Post-run-in electrical or thermal rejects may be used for this test.

9. TEST METHODS AND PROCEDURES

If a Manufacturer elects to eliminate or modify a test method or procedure, the Manufacturer is still responsible for delivering components that meet all of the performance, quality and reliability requirements defined in this specification and the Detail Specification.

Documentation supporting the change shall be approved by the Qualifying Space Agency and retained by the Manufacturer. It shall be copied, when requested, to the Qualifying Space Agency.

The change shall be specified in the Detail Specification and in the P.I.D.

9.1 INTERNAL VISUAL INSPECTION

In accordance with ESCC Basic Specification No. 20400.

9.2 SEAL TEST

The seal test shall be performed in accordance with IEC Publication No. 68-02-17.

(a) Test Qk: Tracer gas method with mass spectrometer. Test method 1 (IEC Para's 6.3, 6.4) with the following requirements:

- Type of tracer gas: Helium, with a purity of no less than 90%.
- Severity: 1000 hours.
- Pressure in the pressure vessel: Maximum $3 \cdot 10^5$ Pa. Absolute.
- Method of removal of surface absorbed tracer gas: External cleaning in air stream.
- Requirements: Acceptable limit for the measured leak rate R as a function of internal volume of case according to the severity.

(b) Test Qc: Container sealing, gas leakage (also called "bubble gross leak test"). Test method 2 (IEC Para. 3.5) with test liquid at elevated temperature and the following requirement:

- Recommended liquids B11: For test temperatures higher than 90°C the liquid shall be a fluoro-carbon liquid FC 40 or FC 43 maintained at a maximum temperature of $125 \pm 5^\circ\text{C}$.

9.3 EXTERNAL VISUAL INSPECTION

In accordance with ESCC Basic Specification No. 20500.

9.4 DIMENSION CHECK

In accordance with ESCC basic Specification No. 20500 and the Detail Specification. To be performed on 5 samples only.

If 1 failure occurs, the complete lot shall be checked.

9.5 ELECTRICAL AND THERMAL MEASUREMENTS

9.5.1 General

For thermostatic switches, some specific temperatures for tests are defined according to the operating thermic diagram as represented below:-

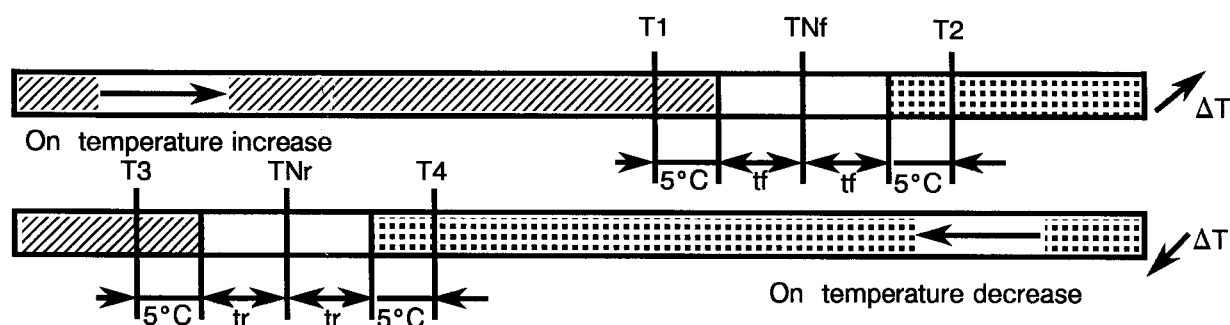

(a) **Switch with opening contact:** The contact will open when the temperature becomes higher than the operating temperature T_f .

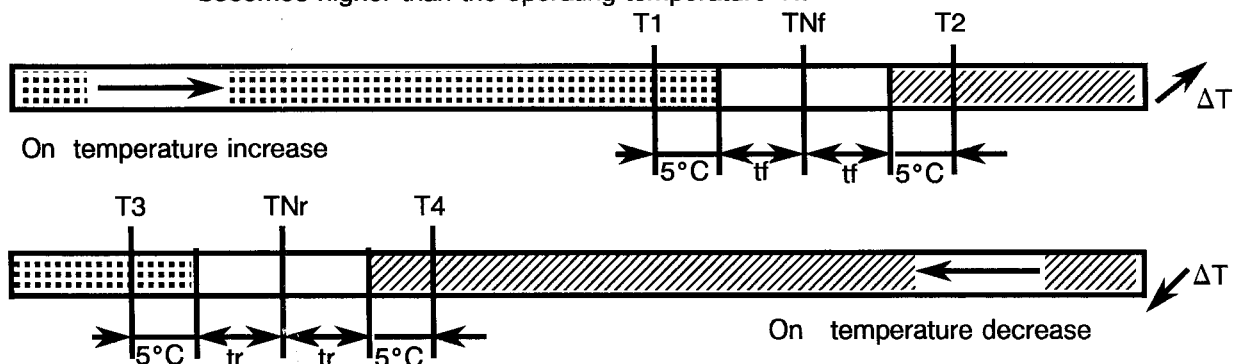

(b) **Switch with closing contact:** The contact will close when the temperature becomes higher than the operating temperature T_f .



T_{Nf} Operating nominal temperature
 T_{Nr} Restoring nominal temperature
 t_f Tolerance attached to T_{Nf}
 t_r Tolerance attached to T_{Nr}
 T_f Operating temperature
 T_r Restoring temperature

 Closed contact
 Open or closed contact
 Open contact

Electrical measurements and methods shall be as follows.

9.5.1.1 Voltage Proof

(a) Voltage proof between contacts and ground:

(Not applicable to types with terminals connected to the case).

- Test: A 50Hz a.c. test voltage in accordance with the Detail Specification shall be progressively applied between the terminals connected together and all other exposed metal parts of the case.
- Requirements: The duration of the voltage application shall be 60 seconds for qualification and 5 seconds for lot acceptance inspection.

(b) Voltage proof between both terminals of the open contact:

(Applicable to all types, including those with a terminal connected to the case).

- Test: A 50Hz a.c. test voltage in accordance with the Detail Specification shall be progressively applied between both terminals of the open contact with test temperatures as follows:
- Either $T \geq T_2$ for types with open contact on increasing temperature after 5 minutes minimum at thermal equilibrium.
- Or $T \leq T_3$ for types with closed contact on increasing temperature after 5 minutes minimum at thermal equilibrium.
- The duration of the voltage application shall be 60 seconds for qualification, and 5 seconds for lot acceptance inspection.
- Requirements: There shall be no breakdown, flashover or current flowing higher than $500\mu\text{A}$ during the voltage application.

	<p style="text-align: center;">ESCC Generic Specification No. 3702</p>	<p style="text-align: right;">PAGE 23 ISSUE 2</p>
---	--	---

9.5.1.2 Insulation Resistance

The insulation resistance shall be measured between the same points and under the same thermal conditions as in Para. 9.5.1.1

The measurement shall be carried out with a d.c. test voltage as specified in the Detail Specification not higher than the rated voltage of the switch, after the voltage has been applied for 60 seconds for qualification and 5 seconds for lot acceptance tests.

- Requirements: Unless otherwise specified in the Detail Specification, the value of the insulation resistance shall not be lower than 500MΩ.

9.5.1.3 Contact Resistance

The measurement of contact resistance shall be carried out, after thermal equilibrium is reached, at $T \leq T3$ for types with open contact on increasing temperature, or at $T \geq T2$ for types with closed contact on increasing temperature. The measurement shall be carried out:

- Either a.c. at a frequency not higher than 50kHz with 20mV peak. One measurement is carried out.
- Or d.c., with an open circuit voltage not exceeding 6V and a current not exceeding 100mA. One measurement carried out for each current direction and the reading shall be the average of the 2 measurements.
- No load shall be applied to the contact during contact transfer.

9.5.1.4 Thermal Measurements

9.5.1.4.1 Test Circuit and Mounting

The test circuit and mounting shall be identical to those for the run-in test (Para. 9.7).

9.5.1.4.2 Test

The switches shall be rapidly set to the temperature T3 and shall undergo 3 identical cycles as follows:

- 3 minutes exposure at temperature T3.
- Passage to temperature T2, the operating temperature Tf is recorded for each switch.
- Return to temperature T3. The restoring temperature Tr, is recorded for each switch (see thermal diagram Figure I).

9.5.1.4.3 Requirements

During each cycle:

- The difference between the measured operating temperature Tf and the nominal operating temperature TNf shall be lower than the tolerance tf, defined in the Detail Specification.
- The difference between the measured restoring temperature Tr and the nominal restoring temperature TNr shall be lower than the tolerance tr, defined in the Detail Specification.
- For the three cycles, the repeatability defined as the difference between the average of the operating temperatures of a switch and any one of these recorded temperatures, shall be lower than 1°C.

After 3 cycles, the average operating temperature and restoring temperature shall be recorded as Tf and Tr.

FIGURE I - THERMAL DIAGRAM FOR THERMAL TEST

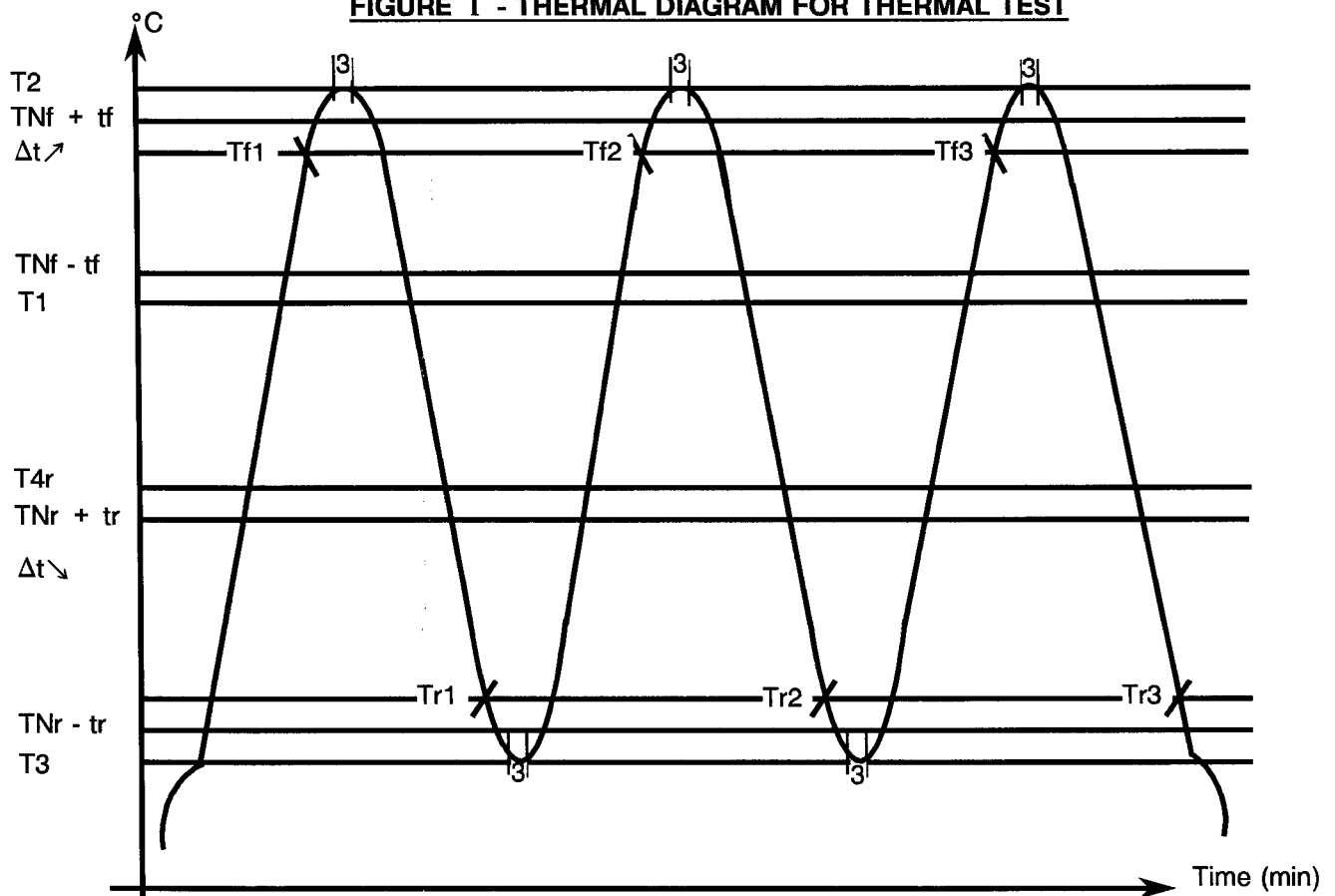

9.5.2 Parameter Drift Value Measurements

At each of the relevant data points for components of testing level 'B', measurements shall be made of all parameters listed in Table 4 of the Detail Specification. All values obtained shall be recorded against serial numbers and the parameter drift calculated. Final production measurements may be used as initial measurements.

9.5.3 Electrical Measurements at High and Low Temperatures

Not applicable.

9.5.4 Electrical and Thermal Measurements

For components of testing levels "B" and "C", the measurements shall be made in accordance with Table 2 of the Detail Specification. Where sample testing is applied, note the requirements of Para. 8.2.3(b). For testing level "B", all values obtained shall be recorded against serial numbers, except during Final Production Tests (Chart II).

9.5.5 Electrical and Thermal Measurements during Endurance Testing

At each of the relevant data points specified for endurance testing, measurements shall be made of all parameters listed in Table 6 of the Detail Specification. All values obtained shall be recorded against serial numbers and the parameter drift calculated, if required.

9.6 CREEPAGE

(For thermostatic switches with snap action only).

Switches shall be tested through 3 complete cycles. Switches shall be heated or cooled as required to cause thermal action. Switch opening and switch closing functions shall both be checked for creepage, i.e. for time-gap between electrical action and mechanical action of the snap disk.

9.6.1 Test Equipment

Test equipment shall consist of one of the following:-

- (a) A low range (10 Ω or less midscale) undamped ohmmeter.
- (b) A milliammeter in series with a resistor and power supply of 6V, 100mA, with a microphone, amplifier and loudspeaker system to audibly monitor disk snap.
- (c) A filament lamp of 3.5V, 0.3A placed in series.

9.6.2 Requirements

The opening and closing of switch contacts shall occur simultaneously with and as a result of the disk snap. The following shall apply:-

- (a) Using the ohmmeter, the needle shall actuate instantly, without hesitation or interrupted action.
- (b) Using the loudspeaker milliammeter equipment, the audible snap of the switch shall occur simultaneously with the actuation of the meter, and the meter needle shall actuate instantly without hesitation or interruption of its swing.
- (c) Using the filament lamp, the lamp shall light or extinguish instantly without hesitation.

FIGURE II - THERMAL DIAGRAM FOR CREEPAGE TEST

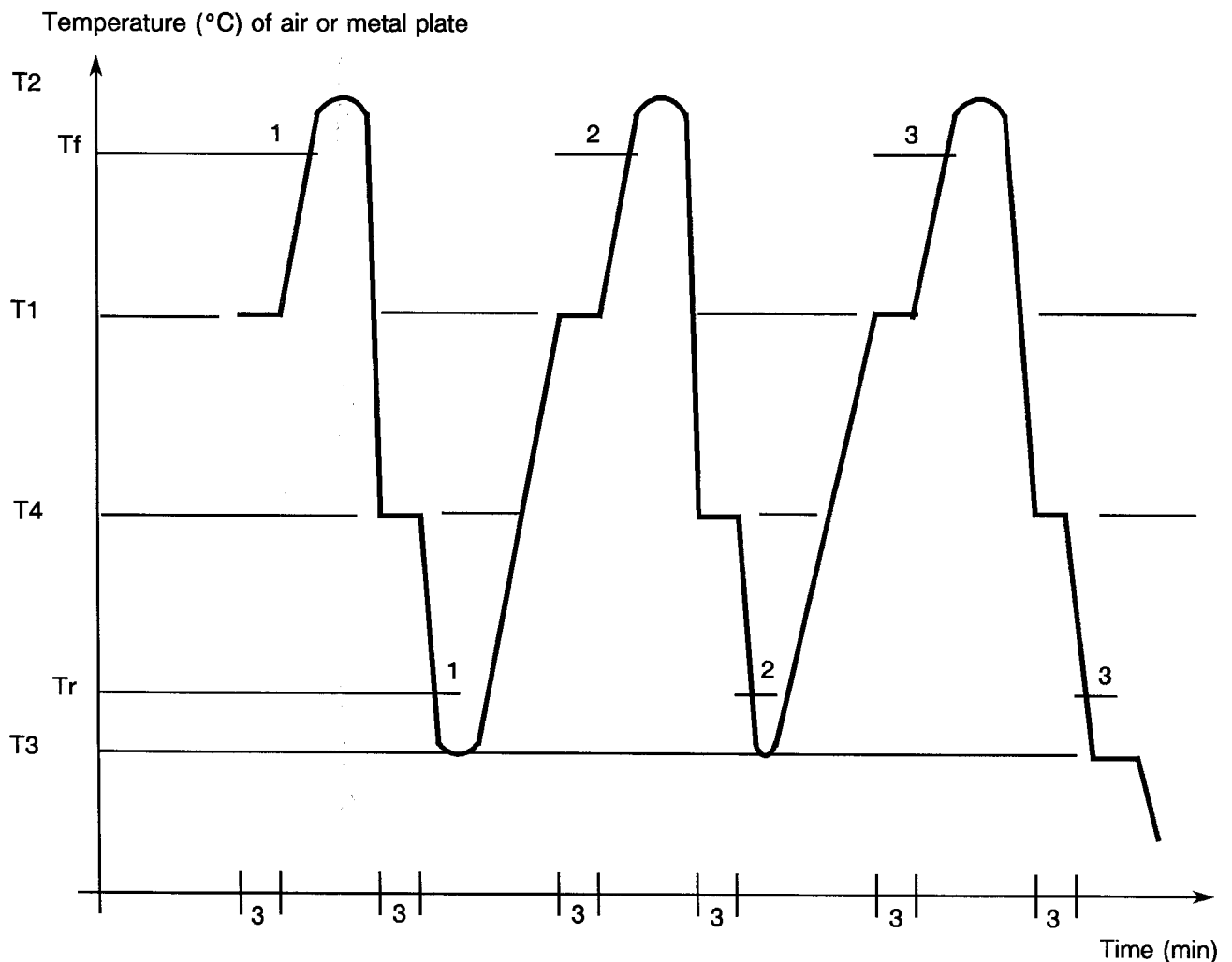

9.7 RUN-IN(a) **Test circuit:**

Each circuit of the switch shall be connected to an individual series-connected filament pilot light. When the contact is closed, the current, dc or ac, shall not be higher than 60mA.

(b) **Test:**

The switches are mounted on an appropriate thermal block, or in a thermal chamber. The temperature is rapidly increased to T1, then successively set to T2 and T3 as defined in the Detail Specification) (see the thermal diagram Figure III). This shall constitute 1 cycle and shall be performed 500 times.

(c) **Requirements:**

During the temperature increase (from T3 to T2) each contact shall open or close and inversely, each contact shall close or open, during the temperature decrease (passage from T2 to T3).

FIGURE III - THERMAL DIAGRAM FOR RUN-IN TEST

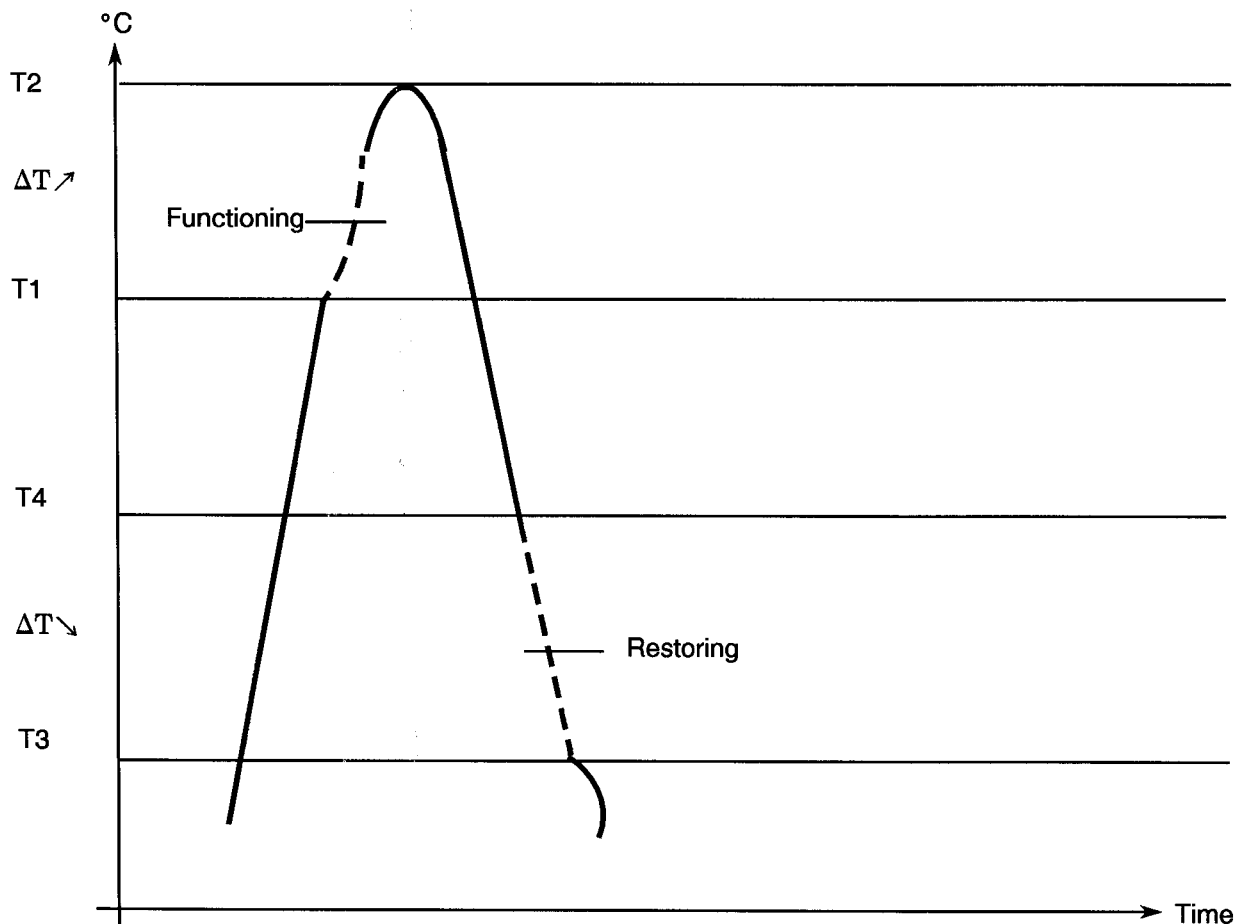

RESPONSE TIME

Three metal blocks B0, B1 and B2 of minimum 250cm³ (eg. a plate of 10x10x2.5 cm) with a polished upper surface and fast clips for mounting and dismounting are used. They are provided with heating and cooling devices, adjustable and stabilisable in temperature. The response time is measured by a chronometer which is able to start and stop by means of an electrical signal.

The blocks B0, B1 and B2 are respectively set to temperatures:

- TB2 = Tf + 10 (+5 - 0) °C.
- TB1 = Tf - 10 ± 3 °C.
- TB0 = T3 - 10 (+0 - 5) °C.

maintained stable during the whole test.

- In a first step, the switch is put on the block B0 for about one minute.
- In a second step, the switch is moved from the block B0 to the block B1, where it is maintained during 5 minutes minimum.
- In a third step, the switch is moved from the block B1 to the block B2, and the chronometre starts at the precise moment when the switch is put in contact with the block B2 and stops when its operating point is reached. The response time is then measured.
- In a fourth and last step, the switch is moved from the block B2 to the block B0, until it reaches its restoring point.

The cycle is repeated three times (see the thermal diagram Figure IV).

The response time, (trp) shall be lower than that defined in Table 6 of the Detail Specification.

NOTES

1. Tf = Operating temperature (see Para. 9.5.1.4)

**FIGURE IV - THERMAL DIAGRAM FOR RESPONSE TIME TEST
(THREE BLOCKS METHOD)**

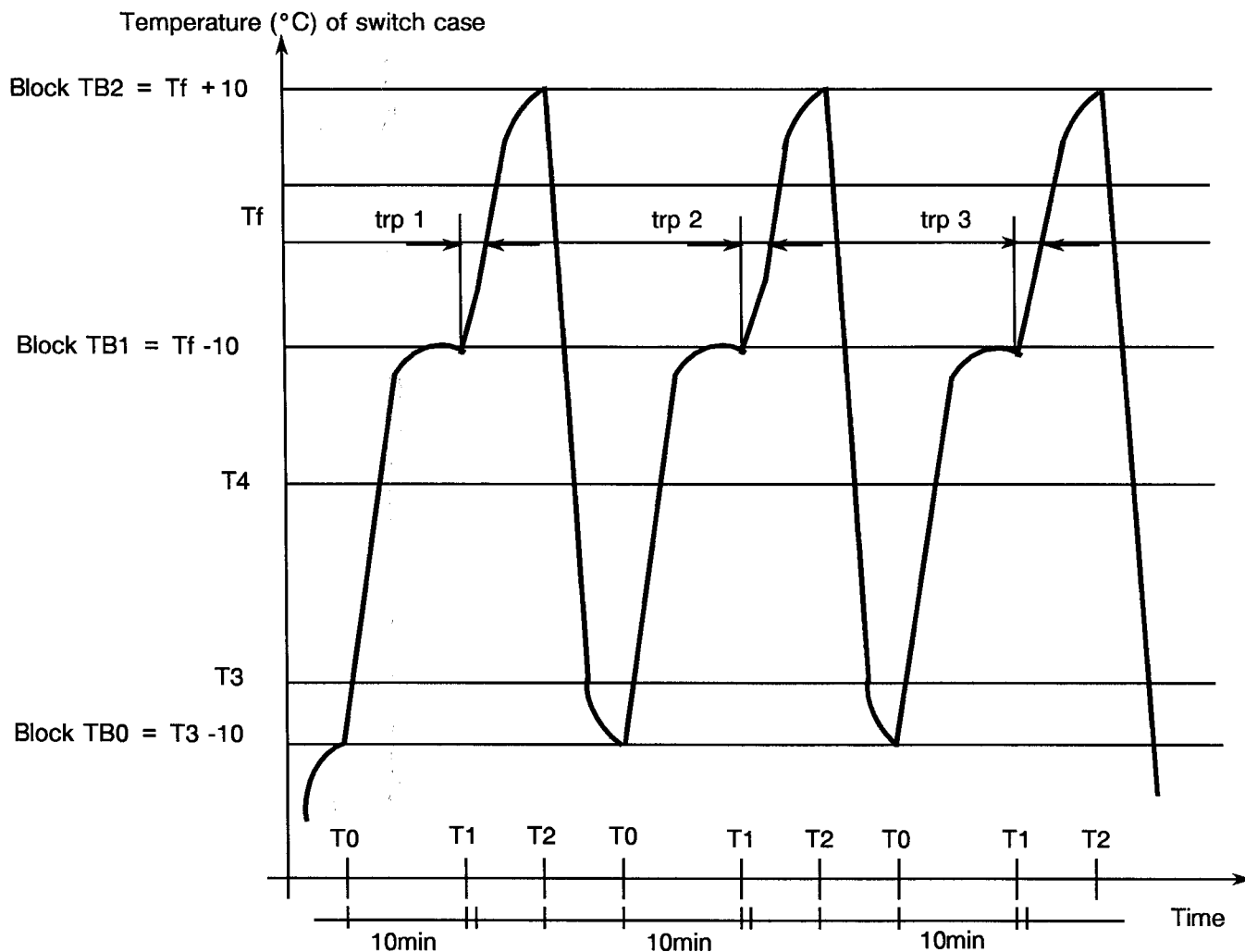



9.9 RAPID CHANGE OF TEMPERATURE

9.9.1 Initial Measurements

None.

9.9.2 Procedure and Recovery

The components shall be submitted to Test 'Na' of IEC Publication No. 68-2-14 for 5 cycles for screening and 10 cycles for qualification and lot acceptance tests. The duration of exposure at each of the storage temperature extremes given in Table 1(b) of the Detail Specification shall be 30 minutes.

The components shall then remain under standard atmospheric conditions for recovery for not less than 1 hour, nor more than 2 hours.

9.9.3 Final Measurements

The components shall be visually examined. There shall be no evidence of damage.

Electrical and thermal Measurements shall be performed in accordance with Table 2 of the Detail Specification.

9.10 VIBRATION

9.10.1 Initial Measurements

None.

9.10.2 Procedure

The components shall be subjected to Test 'Fc', Sub-clause 8.2.1, of IEC Publication No. 68-2-6, taking into account the following details and exceptions:

- If the component is provided with specific mounting means, these shall be used.
- Frequency range, severity: 10 - 2000 Hz 1.5mm or 50g, whichever is less.
2 000 - 3 000 Hz 30g.
- Contact requirements: Normally open contacts shall be monitored for contact closures exceeding 1.0ms and normally closed contacts be monitored for contact opening exceeding 1.0ms.
- Axes of vibration: Main axis and the two other perpendicular directions (total 3 axes): on each axis, half of the total time with open contact and the other half with closed contact.

9.10.3 Conditions

The lot or sample to be tested shall be divided into 2 (roughly) equal parts: one for tests at $T \leq T_3$ to obtain closed (or open) status of the switch and the other at $T \geq T_2$ to obtain open (or closed) status of the switch.

Duration: Minimum 2 hours in each of the 3 axes.

9.10.4 Final Measurements

After the test, the components shall be visually examined and there shall be no evidence of damage.

9.11 SHOCK

9.11.1 Initial Measurements

None.

9.11.2 Procedure

The components shall be subjected to Test 'Ea' of IEC Publication No. 68-2-27, taking into account the following details and exceptions:

- If the component is provided with specific mounting means, these shall be used.
- Severity: 500g, $\frac{1}{2}$ sine, 1.0ms.
- Contact requirements: Normally open contacts shall be monitored for contact closures exceeding 1.0ms and normally closed contacts shall be monitored for contact opening exceeding 1.0ms.

9.11.3 Conditions

The lot or sample to be tested shall be divided into 2 (roughly) equal parts: one for test at $T \leq T3$, to obtain closed (or open) status of the switch and the other at $T \geq T2$ to obtain open (or closed) status of the switch as defined in the Detail Specification. Unless otherwise specified, three successive shocks shall be applied in each of the three mutually perpendicular axes, and on each axis, half of the total time with open contact and the other half with closed contact, so chosen that faults are most likely to be revealed (i.e. in total: 18 shocks). The test voltage shall be 28Vdc and test current 60mAdc.

9.11.4 Final Measurements

The components shall be visually examined. There shall be no evidence of damage.

Electrical and thermal measurements shall be performed in accordance with Table 2 of the Detail Specification.

9.12 ROBUSTNESS OF TERMINATIONS

The components shall be subjected to Tests 'Ua1', 'Ub' and 'Ud' of IEC Publication No. 68-2-21, as applicable and as specified in the Detail Specification.

NOTES

1. Test 'Ub' shall not be applied if the Detail Specification describes the terminations as rigid.

9.12.1 Initial Measurements

None.

9.12.2 Procedure

The applicable force shall be specified in the Detail Specification.

- Test 'Ub': Bending, if applicable.
- Test 'Ud': Torque, if applicable.
- Test 'Ua1': Tensile, if applicable.

9.12.3 Visual Examination

The components shall be visually examined there shall be no evidence of damage, loosening or breaking of the terminals.

9.13 PERMANENCE OF MARKING

In accordance with ESCC Basic Specification No. 24800.

9.14 RESISTANCE TO SOLDERING HEAT

The components shall be subjected to one of the methods of Test 'Tb' of IEC Publication No. 68-2-20.

9.14.1 Initial Measurements

The operating temperature and restoring temperature shall be measured in accordance with Para. 9.5.1.4.

9.14.2 Procedure and Recovery

Either of the following test methods may be used:

- Method 1(a): Solder bath at 260°C (IEC Sub-clause 5.4)
Immersion time: 10 ± 1 sec.
- Method 1(b): Soldering iron at 350°C (IEC Sub-clause 5.6)
Size of soldering iron: A or B.

The components shall remain 30 minutes under standard atmospheric conditions for recovery.

9.14.3 Final Measurements

The components shall be visually examined. There shall be no evidence of damage (cracked glass around terminals, etc) and the marking shall be legible.

Measurements shall be performed in accordance with Table 6 of the Detail Specification.

9.15 DAMP HEAT (STEADY STATE)

The components shall be subjected to Test 'Ca' of IEC Publication No. 68-2-3 with the following details and exceptions:

- Polarisation voltage: Not applicable.
- Special pre-conditioning procedure: None.
- Initial measurements: None.
- Severity: 10 days unless otherwise specified in the Detail Specification.
- During conditioning: No loading, no measurements.

9.16 OVERLOAD

9.16.1 Procedure

The test circuit and mounting are identical to that for the endurance test at nominal load (Para. 9.18).

The test conditions are the same as the endurance test conditions, except that the overload current shall be 1.5 times rated current. The test shall comprise 50 cycles.

9.16.2 Final Measurements

Measurements in accordance with Table 6 of the Detail Specification.

9.17 OPERATING LIFE

9.17.1 Duration

The duration shall be 100 000 cycles.

9.17.2 Method of Mounting

The switches shall be mounted by their own mounting means which allow the thermal exchange with heating and/or cooling sources. The switches, defined with respect to surface temperature shall be fixed on a metal plate of good thermal conductance. The switches defined with respect to ambient temperature, shall be left in free air circulation.

9.17.3 Test Conditions

Each contact shall be connected to a resistive load rated current, ac or dc, as specified in Table 5(b) of the Detail Specification.

During the complete duration of the test, the switches shall be exposed successively to the temperatures causing the operating and the restoring mode. The temperature variation shall be as rapid as possible in order to reduce the test duration, but leading to no more than 6 cycles per minute.

Monitoring equipment shall record both the number of cycles and any failures. If a failure occurs, the monitoring equipment shall discontinue the test. During closure, the contact potential shall be monitored for at least 50% of the closure period.

9.17.4 Intermediate and End Data Points

Measurements at intermediate and end data points in accordance with Table 6 of the Detail Specification at 0, 25000, 50000 and 100000 cycles.

In the case where Table 6 specifies "changes", the drift shall always be related to the 0-hour measurement.

9.17.5 Visual Examination

At intermediate points and on completion of the operating life tests, the components shall be visually examined. There shall be no evidence of damage.

9.18 SOLDERABILITY

The components shall be subjected to Test 'Ta' of IEC Publication No. 68-2-20, using either Method 1 (Solder Bath) or Method 2 (Soldering iron size A or B).

9.18.1 Procedure

When using the Solder Bath method, the wire terminations stated by the Manufacturer to be suitable for use with printed wiring shall be immersed up to $1.5 +0.5 - 0$ mm from the point where the termination emerges from the body, with a suitable heat shield which will simulate a printed wiring board or to half the length of the tape or termination.

9.18.2 Visual Examination

When the test procedures have been carried out, the components shall be visually examined. There shall be no evidence of damage and the marking shall be legible.

9.19 HIGH TEMPERATURE STORAGE

The components shall be subjected to Test 'Ba' of IEC Publication No. 68-2-2.

9.19.1 Duration

The duration shall be 1000 hours.

9.19.2 Method of Mounting

Unspecified.

9.19.3 Test Conditions and Recovery

The test shall be performed at the maximum storage temperature specified in Table 1(b) of the Detail Specification at zero dissipation. The components shall remain under standard atmospheric conditions for recovery for not more than 96 hours.

9.19.4 End Data Points

Measurements at end data points in accordance with Table 6 of the Detail Specification at 0 and 1000 ± 48 hours.

In the case where Table 6 specifies "changes", the drift shall always be related to the 0-hour measurement.

9.20 LOW TEMPERATURE STORAGE

Not used.

9.20.1 Test Conditions

Not used.

9.21 SALT MIST

The components shall be subjected to Test 'Ka' of IEC Publication No. 68-2-11.

9.21.1 Method of Mounting

The components shall be mounted in such a way that the terminal side faces downwards.

9.21.2 Duration

The duration of the test shall be 48 hours.

9.21.3 Visual Examination

After the test, the component shall be examined for evidence of peeling, chipping, blistering of the finish and exposure of base metal due to corrosion.

9.22 ENCAPSULATION

In accordance with the Process Identification Document (P.I.D.).

	<p style="text-align: center;">ESCC Generic Specification No. 3702</p>	<p style="text-align: right;">PAGE 34 ISSUE 2</p>
---	--	---

10. DATA DOCUMENTATION

10.1 GENERAL

For the qualification approval records and with each component delivery, a data documentation package is required. Depending on the testing level and lot acceptance level specified for the component, this package shall be compiled from:-

- (a) Cover sheet (or sheets).
- (b) List of equipment (testing and measuring).
- (c) List of test references.
- (d) Special in-process control test data (when required by the Detail Specification).
- (e) Final production test data (Chart II) (but see Para. 10.6).
- (f) Run-in and electrical measurement data (Chart III).
- (g) Qualification test data (Chart IV).
- (h) Lot acceptance test data (Chart V) (when applicable).
- (i) Failed component list (see Paras. 7.3 and 8.4) and failure analysis report (see Para. 8.4).
- (j) Certificate of Conformity.

Items (a) to (j) inclusive shall be grouped, preferably as subpackages and, for identification purposes, each page shall include the following information:

- ESCC Component number.
- Manufacturer's name.
- Lot identification.
- Date of establishment of the document.
- Page number.

10.1.1 Qualification Approval

In the case of qualification approval, the items listed in Para. 10.1 (a) to (j) less item (h) are required.

10.1.2 Testing Level "B"

10.1.2.1 Qualified Components

For deliveries of qualified components, the following documentation shall be supplied:-

- (a) Cover sheet (if all of the information is not included on the Certificate of Conformity).
- (b) Certificate of Conformity (including range of delivered serial numbers).
- (c) Attributes record of measurements, tests and inspections performed in Chart II, Chart III (including PDA figure) and Chart V (where applicable).
- (d) Failed components list.

	<p style="text-align: center;">ESCC Generic Specification No. 3702</p>	<p style="text-align: right;">PAGE 35 ISSUE 2</p>
---	--	---

10.1.2.2 Unqualified Components

For deliveries of unqualified components, the documentation to be supplied shall be in accordance with Para. 10.1.2.1 plus the following:-

- (a) Read and record data from Chart III.
- (b) Special in-process control data (where applicable).
- (c) Failure analysis report on failed components.

10.1.3 Testing Level "C"

10.1.3.1 Qualified Components

For deliveries of qualified components, the following documentation shall be supplied:-

- (a) Certificate of Conformity.

10.1.3.2 Unqualified Components

For deliveries of unqualified components, the documentation to be supplied shall be in accordance with Para. 10.1.3.1 plus the following:-

- (a) Cover sheet (if all of the information is not included on the Certificate of Conformity).
- (b) Attributes record of all measurements, tests and inspections performed in Charts II, III and V (when applicable).
- (c) Failed components list (including Failure Analysis Report).
- (d) Special in-process control data (when applicable).

10.1.4 Data Retention/Data Access

If not delivered, all data shall be retained by the Manufacturer for a minimum of 5 years during which time it shall be available to the Qualifying Space Agency and the Orderer, if requested, for review. The Manufacturer shall deliver variables Data/Reports to the Orderer if required by the Purchase Order.

10.2 COVER SHEET(S)

The cover sheet(s) of the data documentation package shall include as a minimum:-

- (a) Reference to the Detail Specification, including issue and date.
- (b) Reference to the applicable ESCC Generic Specification, including issue and date.
- (c) Component type and number.
- (d) Lot identification.
- (e) Range of delivered serial numbers (for components of testing level "B").
- (f) Number of purchase order.
- (g) Information relative to any additions to this specification and/or the Detail Specification.
- (h) Manufacturer's name and address.
- (j) Location of the manufacturing plant.
- (k) Signature on behalf of Manufacturer.
- (l) Total number of pages of the data package.

10.3 LIST OF EQUIPMENT USED

A list of equipment used for tests and measurements shall be prepared, if not in accordance with the data given in the Process Identification Document (P.I.D.). Where applicable, this list shall contain inventory number, Manufacturer's type number, serial number, etc. This list shall indicate for which tests such equipment was used.

10.4 LIST OF TEST REFERENCES

This list shall include all Manufacturer's references or codes which are necessary to correlate the test data provided with the applicable tests specified in the tables of the Detail Specification.

10.5 SPECIAL IN-PROCESS CONTROL DATA

As specified in the Detail Specification.

10.6 FINAL PRODUCTION TEST DATA (CHART II)

A test result summary shall be compiled showing the total number of components submitted to, and the total number rejected after, each of the following tests:

- Electrical and thermal measurements (Para. 9.5.4).
- Seal test (Para. 9.2) (when applicable).
- External visual inspection (Para. 9.3).
- Dimension check (Para. 9.4).

The final production test data shall form an integral part of the data documentation package, but it is not a mandatory requirement that it be delivered with the qualification lot or delivery lot. However, the data package to be delivered shall contain the information as detailed in Paras. 10.1.2 and 10.1.3 or at least shall contain a list of final production tests actually performed and a certification that the data is available for review.

10.7 RUN-IN AND ELECTRICAL MEASUREMENT DATA (CHART III)

10.7.1 Testing Level "B"

For components of testing level "B", all data shall refer to the relevant serial numbers. Against these serial numbers, data shall be recorded of the following:-

- (a) Rapid change of temperature.
- (b) 0-cycle measurement for run-in.
- (c) 500-cycle measurement for run-in.
- (d) Delta values after run-in.
- (e) Creepage.
- (f) Values obtained during electrical and thermal measurements (Table 2 of the Detail Specification).
- (g) Failures during external visual inspection.

10.7.2 Testing Level "C"

For components of testing level "C", a test result summary (i.e. the total number of components subjected to, and the total number rejected from, each of the tests and inspections) shall be prepared.

	<p style="text-align: center;">ESCC Generic Specification No. 3702</p>	<p style="text-align: right;">PAGE 37 ISSUE 2</p>
---	--	---

10.8 QUALIFICATION TEST DATA (CHART IV)

All data shall be referenced to the relevant serial numbers. Detailed records shall be provided of the components submitted to each test in each of the subgroups and of those rejected.

Detailed data shall be provided of all electrical and thermal measurements made in accordance with Tables 2 and 6 of the Detail Specification, as and where applicable.

10.9 LOT ACCEPTANCE TEST DATA (CHART V)

10.9.1 Testing Level "B"

All data shall be referenced to the relevant serial numbers. Detailed records shall be provided of the components submitted to each test in each of the subgroups (as relevant to the lot acceptance level) and of those rejected.

Detailed data shall be provided of all electrical and thermal measurements made in accordance with Tables 2, 3 and 6 of the Detail Specification, as and where applicable.

10.9.2 Testing Level "C"

A test result summary (i.e. the total number of components submitted to, and and the total number rejected from, each of the tests and inspections) as relevant to the lot acceptance level shall be provided.

In the case of lot acceptance 2 testing, all data in respect of electrical and thermal measurements made in accordance with Table 6 of the Detail Specification shall be referenced to the relevant serial numbers (see Para. 8.2.4(a)).

In the case of lot acceptance 1 testing, all data in respect of electrical and thermal measurements made in accordance with Tables 2 and 6 of the Detail Specification shall be referenced to the relevant serial numbers (see Para. 8.2.5(a)).

10.10 FAILED COMPONENTS LIST AND FAILURE ANALYSIS REPORT

The failed component list and failure analysis report shall provide full details of:-

- (a) The reference number and description of the test or measurement performed as defined in this specification and/or the Detail Specification.
- (b) The serial number (if applicable) of the failed component.
- (c) The failed parameter and the failure mode of the component.
- (d) Detailed failure analysis, if requested.

10.11 CERTIFICATE OF CONFORMITY

A Certificate of Conformity shall be established as defined in ESCC Basic Specification No. 20100.

11. DELIVERY

For qualification approval, the disposition of the qualification test lot and its related documentation shall be as specified in ESCC Basic Specification No. 20100 and the relevant paragraphs of Section 10 of this specification.

For procurement, for each order, the items forming the delivery are:-

- (a) The delivery lot.
- (b) The components used for lot acceptance testing, (when applicable), but not forming part of the delivery lot (see Para's 8.2.3(d), 8.2.4(b) and 8.2.5(b)).
- (c) The relevant documentation in accordance with the requirements of Section 10 of this specification.

In the case of a component for which a valid qualification approval is in force, all data of all components submitted to LA1 and LA2 testing shall also be copied, when requested, to the relevant Qualifying Space Agency.

12. PACKAGING AND DESPATCH

The packaging and despatch of components to this specification shall be in accordance with the requirements of ESCC Basic Specification No. 20600.



ANNEXE I

LTPD SAMPLING PLAN LOT SIZES GREATER THAN 200 DEVICES

Minimum size of sample to be tested to assure with a 90% confidence that a lot whose Percent Defective equals the specified LTPD is not accepted (single sample).

Max. Percent Defective (LTPD) or λ	50	30	20	15	10	7	5	3	2	1.5	1	0.7	0.5	0.3	0.2	0.15	0.1
Acceptance Number (c) ($r = c + 1$)	MINIMUM SAMPLE SIZES (FOR DEVICE-HOURS REQUIRED FOR LIFE TEST, MULTIPLY BY 1000)																
0	5 (1.03)	8 (0.64)	11 (0.46)	15 (0.34)	22 (0.23)	32 (0.16)	45 (0.11)	76 (0.07)	116 (0.04)	153 (0.03)	231 (0.02)	328 (0.02)	461 (0.01)	767 (0.007)	1152 (0.005)	1534 (0.003)	2303 (0.002)
1	8 (4.4)	13 (2.7)	18 (2.0)	25 (1.4)	38 (0.94)	55 (0.65)	77 (0.46)	129 (0.28)	195 (0.18)	258 (0.14)	390 (0.09)	555 (0.06)	778 (0.045)	1296 (0.027)	1946 (0.018)	2592 (0.013)	3891 (0.009)
2	11 (7.4)	18 (4.5)	25 (3.4)	34 (2.24)	52 (1.6)	75 (1.1)	105 (0.78)	176 (0.47)	266 (0.31)	354 (0.23)	533 (0.15)	759 (0.11)	1065 (0.080)	1773 (0.045)	2662 (0.031)	3547 (0.022)	5323 (0.015)
3	13 (10.5)	22 (6.2)	32 (4.4)	43 (3.2)	65 (2.1)	94 (1.5)	132 (1.0)	221 (0.62)	333 (0.41)	444 (0.31)	668 (0.20)	953 (0.14)	1337 (0.10)	2226 (0.062)	3341 (0.041)	4452 (0.031)	6681 (0.018)
4	16 (12.3)	27 (7.3)	38 (5.3)	52 (3.9)	78 (2.6)	113 (1.8)	158 (1.3)	265 (0.75)	398 (0.50)	531 (0.37)	798 (0.25)	1140 (0.17)	1599 (0.12)	2663 (0.074)	3997 (0.049)	5327 (0.037)	7994 (0.025)
5	19 (13.8)	31 (8.4)	45 (6.0)	60 (4.4)	91 (2.9)	131 (2.0)	184 (1.4)	308 (0.85)	462 (0.57)	617 (0.42)	927 (0.28)	1323 (0.20)	1855 (0.14)	3090 (0.085)	4638 (0.056)	6181 (0.042)	9275 (0.028)
6	21 (15.6)	35 (9.4)	51 (6.6)	68 (4.9)	104 (3.2)	149 (2.2)	209 (1.6)	349 (0.94)	528 (0.62)	700 (0.47)	1054 (0.31)	1503 (0.22)	2107 (0.155)	3509 (0.093)	5267 (0.062)	7019 (0.047)	10533 (0.031)
7	24 (16.6)	39 (10.2)	57 (7.2)	77 (5.3)	116 (3.5)	166 (2.4)	234 (1.7)	390 (1.0)	589 (0.67)	783 (0.51)	1178 (0.34)	1680 (0.24)	2355 (0.17)	3922 (0.101)	5886 (0.067)	7845 (0.051)	11771 (0.034)
8	26 (18.1)	43 (10.9)	63 (7.7)	85 (5.6)	128 (3.7)	184 (2.6)	258 (1.8)	431 (1.1)	648 (0.72)	864 (0.54)	1300 (0.36)	1854 (0.25)	2599 (0.18)	4329 (0.108)	6498 (0.072)	8660 (0.054)	12995 (0.036)
9	28 (19.4)	47 (11.5)	69 (8.1)	93 (6.0)	140 (3.9)	201 (2.7)	282 (1.9)	471 (1.2)	709 (0.77)	945 (0.58)	1421 (0.38)	2027 (0.27)	2842 (0.19)	4733 (0.114)	7103 (0.077)	9468 (0.057)	14206 (0.038)
10	31 (19.9)	51 (12.1)	75 (8.4)	100 (6.3)	152 (4.1)	218 (2.9)	306 (2.0)	511 (1.2)	770 (0.80)	1025 (0.60)	1541 (0.40)	2199 (0.28)	3082 (0.20)	5133 (0.120)	7704 (0.080)	10268 (0.060)	15407 (0.040)
11	33 (21.0)	54 (12.8)	83 (8.3)	111 (6.2)	166 (4.2)	238 (2.9)	332 (2.1)	555 (1.2)	832 (0.83)	1109 (0.62)	1664 (0.42)	2378 (0.29)	3323 (0.21)	5546 (0.12)	8319 (0.083)	11092 (0.062)	16638 (0.042)
12	36 (21.4)	59 (13.0)	89 (8.6)	119 (6.5)	178 (4.3)	254 (3.0)	356 (2.2)	594 (1.3)	890 (0.86)	1187 (0.65)	1781 (0.43)	2544 (0.3)	3562 (0.22)	5936 (0.13)	8904 (0.086)	11872 (0.065)	17808 (0.043)
13	38 (22.3)	63 (13.4)	95 (8.9)	126 (6.7)	190 (4.5)	271 (3.1)	379 (2.26)	632 (1.3)	948 (0.89)	1264 (0.67)	1896 (0.44)	2709 (0.31)	3793 (0.22)	6321 (0.134)	9482 (0.089)	12643 (0.067)	18964 (0.045)
14	40 (23.1)	67 (13.8)	101 (9.2)	134 (6.9)	201 (4.6)	288 (3.2)	403 (2.3)	672 (1.4)	1007 (0.92)	1343 (0.69)	2015 (0.46)	2878 (0.32)	4029 (0.23)	6716 (0.138)	10073 (0.092)	13431 (0.069)	20146 (0.046)
15	43 (23.3)	71 (14.1)	107 (9.4)	142 (7.1)	213 (4.7)	305 (3.3)	426 (2.36)	711 (1.41)	1066 (0.94)	1422 (0.71)	2133 (0.47)	3046 (0.33)	4265 (0.235)	7108 (0.141)	10662 (0.094)	14216 (0.070)	21324 (0.047)
16	45 (24.1)	74 (14.0)	112 (9.7)	150 (7.2)	225 (4.8)	321 (3.37)	450 (2.41)	750 (1.44)	1124 (0.96)	1499 (0.72)	2249 (0.48)	3212 (0.337)	4497 (0.241)	7496 (0.144)	11244 (0.096)	14992 (0.072)	22487 (0.048)
17	47 (24.7)	79 (14.7)	118 (9.86)	158 (7.36)	236 (4.93)	338 (3.44)	473 (2.46)	788 (1.48)	1182 (0.98)	1576 (0.74)	2364 (0.49)	3377 (0.344)	4728 (0.246)	7880 (0.148)	11819 (0.098)	15759 (0.074)	23639 (0.049)
18	50 (24.9)	83 (15.0)	124 (10.0)	165 (7.54)	248 (5.02)	354 (3.51)	496 (2.51)	826 (1.51)	1239 (1.0)	1652 (0.75)	2478 (0.50)	3540 (0.351)	4956 (0.251)	8260 (0.151)	12390 (0.100)	16520 (0.075)	24780 (0.050)
19	52 (25.5)	86 (15.4)	130 (10.2)	173 (7.76)	259 (5.12)	370 (3.58)	518 (2.56)	864 (1.53)	1296 (1.02)	1728 (0.77)	2591 (0.52)	3702 (0.358)	5183 (0.256)	8638 (0.153)	12957 (0.102)	17276 (0.077)	25914 (0.051)
20	54 (26.1)	90 (15.6)	135 (10.4)	180 (7.82)	271 (5.19)	386 (3.65)	541 (2.60)	902 (1.56)	1353 (1.04)	1803 (0.78)	2705 (0.52)	3864 (0.364)	5410 (0.260)	9017 (0.156)	13526 (0.104)	18034 (0.078)	27051 (0.052)
26	65 (27.0)	109 (16.1)	163 (10.8)	217 (8.08)	326 (5.38)	466 (3.76)	652 (2.69)	1086 (1.61)	1629 (1.08)	2173 (0.807)	3259 (0.538)	4656 (0.376)	6518 (0.269)	10863 (0.161)	16295 (0.108)	21726 (0.081)	32589 (0.054)

- (1) Sample sizes are based upon the Poisson exponential binomial limit.
- (2) The minimum quality (approximate AQL) required to accept (on the average) 19 of 20 lots is shown in parentheses for information only.

	ESCC Generic Specification No. 3702		PAGE 41 ISSUE 2
---	--	--	--------------------

ANNEXE I

Page 3 of 3

This table gives the AQL and LTPD values associated with certain single sampling plans (Acceptance Number "C", Sample Size "n" and Lot Size "N"). The table has the following features:-

- (a) Calculations are based upon the hyper-geometric distribution (exact theory) for lot sizes of 200 devices or less.
- (b) The AQL of a sampling plan is defined as the interpolated Percent Defective for which there is a 0.95 probability of acceptance under the plan. The AQL so defined need not be a realisable Lot Percent Defective for the lot size involved (e.g., 12 percent is not a realisable Percent Defective for a lot size of 20 devices).
- (c) The LTPD of a sampling plan is defined as the interpolated Percent Defective for which there is a 0.10 probability of lot acceptance under the plan. The LTPD so defined need not be a realisable Lot Percent Defective for the lot size involved.
- (d) The sequence of sample sizes and lot sizes are generated by taking products of preceding numbers in the respective sequences and the numbers 2 and 5.