



**SWITCHES, THERMOSTATIC, BIMETALLIC,**

**SPST, OPENING CONTACT**

**ESCC Detail Specification No. 3702/001**

**ISSUE 1**

**October 2002**



	ESCC Detail Specification		PAGE ii ISSUE 1
---	---------------------------	--	--------------------

### **LEGAL DISCLAIMER AND COPYRIGHT**

European Space Agency, Copyright © 2002. All rights reserved.

The European Space Agency disclaims any liability or responsibility, to any person or entity, with respect to any loss or damage caused, or alleged to be caused, directly or indirectly by the use and application of this ESCC publication.

This publication, without the prior permission of the European Space Agency and provided that it is not used for a commercial purpose, may be:

- copied in whole in any medium without alteration or modification.
- copied in part, in any medium, provided that the ESCC document identification, comprising the ESCC symbol, document number and document issue, is removed.



europaean space agency  
agence spatiale européenne

Pages 1 to 17

**SWITCHES, THERMOSTATIC, BIMETALLIC,  
SPST, OPENING CONTACT,**

**ESA/SCC Detail Specification No. 3702/001**




**space components  
coordination group**

Issue/Rev.	Date	Approved by	
		SCCG Chairman	ESA Director General or his Deputy
Issue 4	February 2000		
Revision 'A'	November 2000		
Revision 'B'	July 2001		





**TABLE OF CONTENTS**

	<u>Page</u>
<b>1. <u>GENERAL</u></b>	<b>5</b>
1.1 Scope	5
1.2 Type Variants and Range of Components	5
1.3 Maximum Ratings	5
1.4 Parameter Derating Information	5
1.5 Physical Dimensions	5
1.6 Functional Diagram	5
<b>2. <u>APPLICABLE DOCUMENTS</u></b>	<b>5</b>
<b>3. <u>TERMS, DEFINITIONS, ABBREVIATIONS, SYMBOLS AND UNITS</u></b>	<b>5</b>
<b>4. <u>REQUIREMENTS</u></b>	<b>11</b>
4.1 General	11
4.2 Deviations from Generic Specification	11
4.2.1 Deviations from Special In-process Controls	11
4.2.2 Deviations from Final Production Tests	11
4.2.3 Deviations from Run-in and Electrical Measurements	11
4.2.4 Deviations from Qualification Tests	11
4.2.5 Deviations from Lot Acceptance Tests	11
4.3 Mechanical Requirements	11
4.3.1 Dimension Check	11
4.3.2 Weight	11
4.3.3 Robustness of Terminations	11
4.4 Materials and Finishes	12
4.4.1 Case	12
4.4.2 Terminals	12
4.5 Marking	12
4.5.1 General	12
4.5.2 Terminal Identification	12
4.5.3 The SCC Component Number	12
4.5.4 Temperature Characteristics	12
4.5.5 Traceability Information	13
4.6 Electrical Measurements	13
4.6.1 Electrical and Thermal Measurements	13
4.6.2 Electrical Measurements at High and Low Temperatures	13
4.7 Run-in	13
4.7.1 Measurements during Run-in	13
4.7.2 Conditions for Run-in	13
4.7.3 Electrical Circuits for Run-in	13
4.8 Environmental and Endurance Testing	16
4.8.1 Measurements and Inspections on Completion of Environmental Tests	16
4.8.2 Measurements and Inspections during Endurance Tests	16
4.8.3 Measurements and Inspections on Completion of Endurance Tests	16
4.8.4 Conditions for Operating Life Test	16
4.8.5 Electrical Circuits for Operating Life Test	16

	<p style="text-align: center;">ESA/SCC Detail Specification No. 3702/001</p>	<p>PAGE 4 ISSUE 4</p>
--	--	---------------------------

**TABLE OF CONTENTS**

		<u>Page</u>
<b><u>TABLES</u></b>		
1(a)	Type Variants and Range of Components	6
1(b)	Maximum Ratings	7
2	Electrical and Thermal Measurements	14
3	Electrical Measurements at High and Low Temperatures	N/A
4	Parameter Drift Values	15
5(a)	Conditions for Run-in	15
5(b)	Conditions for Operating Life Test	15
6	Measurements and Inspections on Completion of Environmental Tests and at Intermediate Points and on Completion of Endurance Testing	17
 <b><u>FIGURES</u></b>		
1	Parameter Derating Information	7
2	Physical Dimensions	8
3	Functional Diagram	10
 <b><u>APPENDICES (Applicable to specific Manufacturers only)</u></b>		
None		

 	<p style="text-align: center;">ESA/SCC Detail Specification No. 3702/001</p>		<p>PAGE 5 ISSUE 4</p>
---	--	--	---------------------------

1. **GENERAL**

1.1 **SCOPE**

This specification details the ratings, physical and electrical characteristics, test and inspection data for Switches, Thermostatic, Bimetallic , 4A, 30V, SPST, Opening Contact. It shall be read in conjunction with ESA/SCC Generic Specification No. 3702 the requirements of which are supplemented herein.

1.2 **TYPE VARIANTS AND RANGE OF COMPONENTS**

Variants of the basic type switches specified herein, which are also covered by this specification are given in Table 1(a).

1.3 **MAXIMUM RATINGS**

The maximum ratings, which shall not be exceeded at any time during use or storage, applicable to the switches specified herein, are as scheduled in Table 1(b).

1.4 **PARAMETER DERATING INFORMATION**

The current rating versus voltage shall be as shown in Figure 1.

1.5 **PHYSICAL DIMENSIONS**

The physical dimensions of the switches specified herein are shown in Figure 2.

1.6 **FUNCTIONAL DIAGRAM**

The functional diagram for the switches specified herein, is shown in Figure 3.

2. **APPLICABLE DOCUMENTS**

The following documents form part of this specification and shall be read in conjunction with it:-

- (a) ESA/SCC Generic Specification No. 3702 , Switches, Thermostatic, Bimetallic, Hermetically Sealed.

3. **TERMS, DEFINITIONS, ABBREVIATIONS, SYMBOLS AND UNITS**

For the purpose of this specification, the terms, definitions, abbreviations, symbols and units specified in ESA/SCC Basic Specification No. 21300 and IEC Publication 389-1, Thermostatic Switches Part 1, shall apply.



**TABLE 1(a) - TYPE VARIANTS AND RANGE OF COMPONENTS**

TYPE VARIANTS

VARIANT	MECHANICAL DIFFERENCES	FIGURE
01	Without mounting appliance	2(a)
02	Mounting with 2 hole flange	2(b)
03	Mounting with threaded stud (5.0mm)	2(c)
04	Mounting with threaded stud (10mm)	2(d)
05	Mounting with 1 open-hole flange	2(e)
06	Mounting with 2 open-hole flange	2(f)

RANGE OF COMPONENTS

GRADE 1

TNf Range (°C)	TOLERANCE (°C)	TNf - TNr (°C)	Tf - Tr (°C)	
			Min.	Max.
- 50 to - 36	±5.0	10	8.0	18
- 35 to + 79	±3.0	10	7.0	12
		9.0	6.4	11.2
		8.0	5.8	10.4
		7.0	5.2	9.6
		6.0	4.6	8.8
		5.0	4.0	8.0
+ 80 to + 150	±5.0	15	10	19

GRADE Y

TNf Range (°C)	TOLERANCE (°C)	TNf - TNr Min. (°C)
- 50 to - 36	±5.0	10
- 35 to + 79	±3.0	5.0
+ 80 to + 150	±5.0	15

GRADE Z

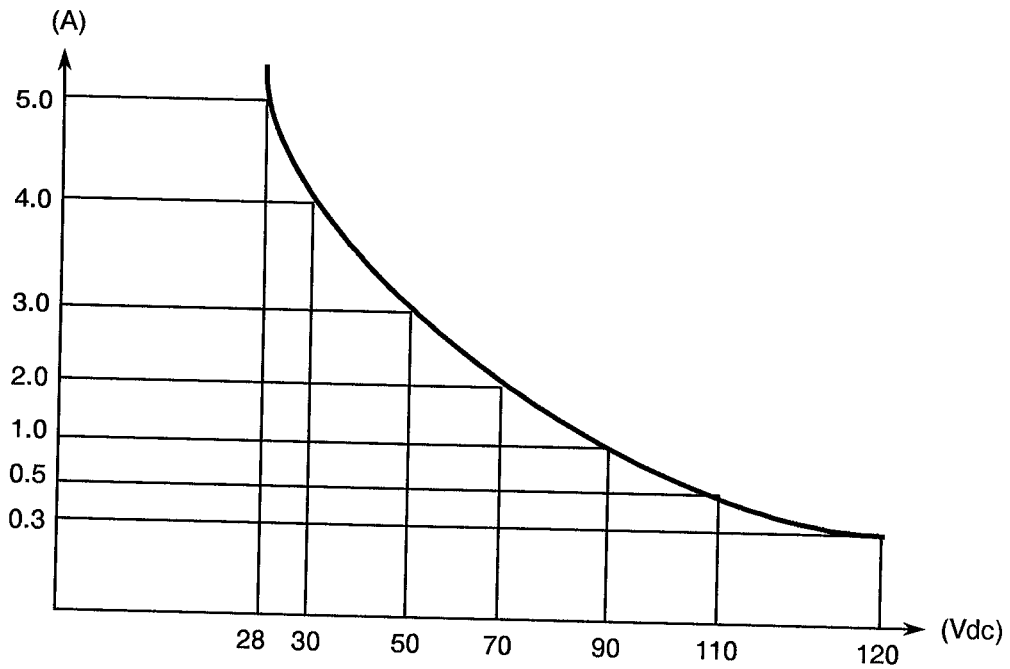
TNf Range (°C)	TNf - TNr Min. (°C)	Tf - Tr Min. (°C)
- 50 to + 150	15	3.5



**TABLE 1(b) - MAXIMUM RATINGS**

NO.	CHARACTERISTICS	SYMBOL	MAXIMUM RATINGS	UNITS	REMARKS
1	Rated Current d.c.	$I_R$	4.0	A	30Vdc resistive
2	Overload Current d.c.	$I_{overl}$	6.0	A	30Vdc resistive
3	Operating Temperature Range	$T_{op}$	- 50 to + 150	°C	
4	Storage Temperature Range	$T_{stg}$	- 65 to + 175	°C	

**FIGURE 1 - PARAMETER DERATING INFORMATION**



Current versus Voltage



**FIGURE 2 - PHYSICAL DIMENSIONS**

FIGURE 2(a) - VARIANT 01

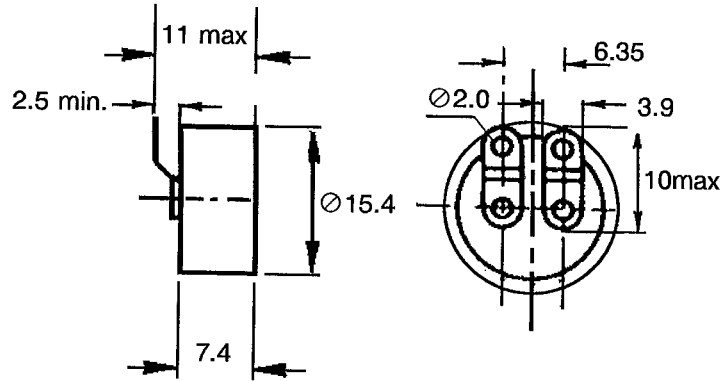
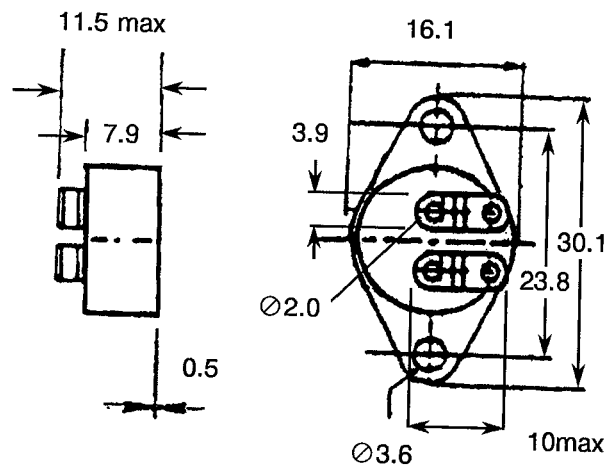


FIGURE 2(b) - VARIANT 02



**NOTES**

1. All dimensions are in millimetres.
2. Tolerance  $\pm 0.1$ mm, unless otherwise specified.



**FIGURE 2 - PHYSICAL DIMENSIONS (CONTINUED)**

FIGURE 2(c) - VARIANT 03

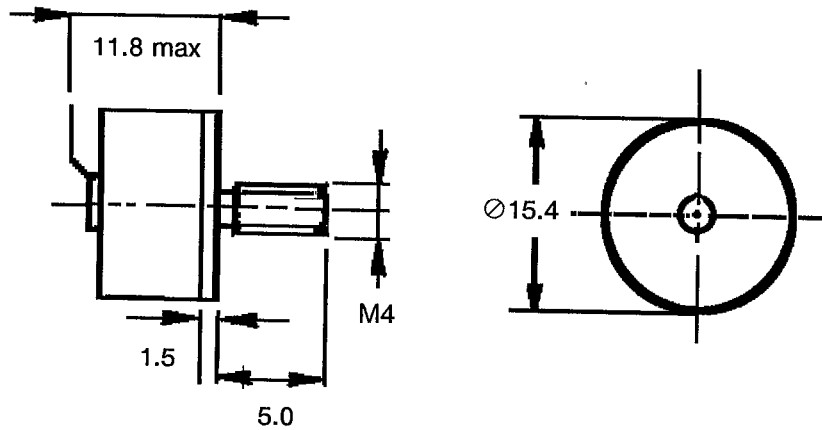
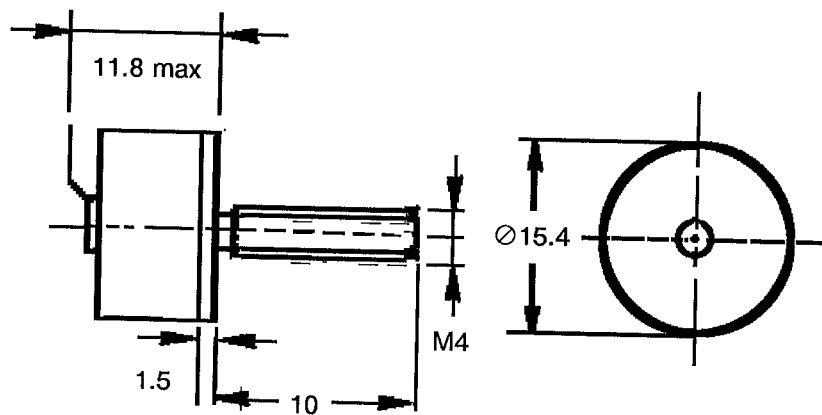


FIGURE 2(d) - VARIANT 04



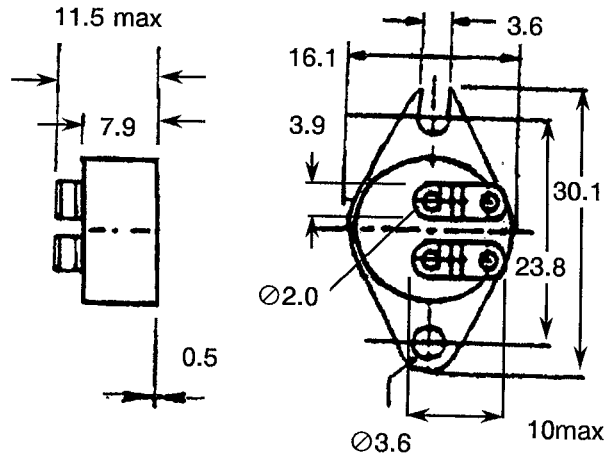
**NOTES**

1. All dimensions are in millimetres.
2. Tolerance  $\pm 0.1\text{mm}$ , unless otherwise specified.

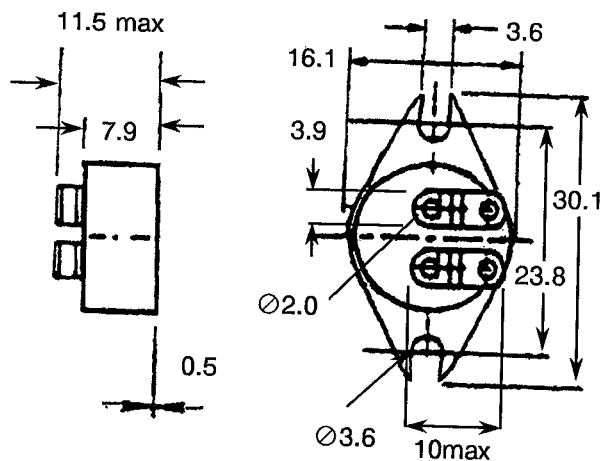


**FIGURE 2 - PHYSICAL DIMENSIONS (CONTINUED)**

**FIGURE 2(e) - VARIANT 05**



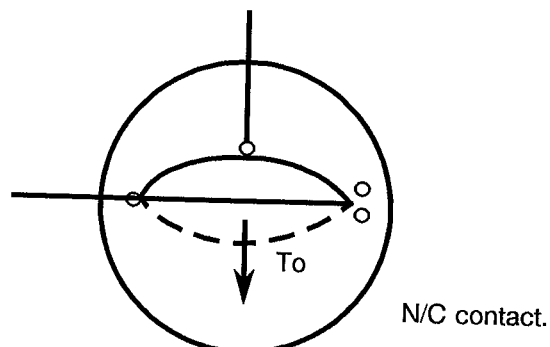
**FIGURE 2(f) - VARIANT 06**




**NOTES**

1. All dimensions are in millimetres.
2. Tolerance  $\pm 0.1\text{mm}$ , unless otherwise specified.

**FIGURE 3 - FUNCTIONAL DIAGRAM**



	<p style="text-align: center;">ESA/SCC Detail Specification No. 3702/001</p>	<p style="text-align: right;">PAGE 11 ISSUE 4</p>
--	--	---

**4. REQUIREMENTS**

**4.1 GENERAL**

The complete requirements for procurement of the switches specified herein are stated in this specification and ESA/SCC Generic Specification No. 3702 for Thermostatic Switches. Deviations from the Generic Specification, applicable to this specification only, are listed in Para. 4.2.

Deviations from the applicable Generic Specification and this Detail Specification, formally agreed with specific Manufacturers on the basis that the alternative requirements are equivalent to the ESA/SCC requirements and do not affect the component's reliability, are listed in the Appendices attached to this specification.

**4.2 DEVIATIONS FROM GENERIC SPECIFICATION**

**4.2.1 Deviations from Special In-process Controls**

None.

**4.2.2 Deviations from Final Production Tests (Chart II)**

(a) Para. 9.2, Seal Test: See Table 6, No. 1 for value.

**4.2.3 Deviations from Run-in and Electrical Measurements (Chart III)**

(a) Para. 9.2, Seal Test: See Table 6, No. 1 for value.

**4.2.4 Deviations from Qualification Tests (Chart IV)**

(a) Para 9.12, Robustness of Terminations: Tests 'Ub' and 'Ud' are not applicable.

(b) Para. 9.18, Solderability: Soldering Iron Size B for Method 2.

**4.2.5 Deviations from Lot Acceptance Tests (Chart V)**

(a) Para 9.12, Robustness of Terminations: Test 'Ub' and 'Ud' are not applicable.

(b) Para. 9.18, Solderability: Soldering Iron Size B for Method 2.

**4.3 MECHANICAL REQUIREMENTS**

**4.3.1 Dimension Check**

The dimensions of the switches specified herein shall be verified in accordance with the requirements set out in Paragraph 9.4 of ESA/SCC Specification No. 3702 and shall conform to those shown in Figure 2.

**4.3.2 Weight**

The maximum weight of the switches specified herein shall be 7.5 grammes for Variants 01, 02, 05 and 06, 8.0 grammes for Variants 03 and 04.

**4.3.3 Robustness of Termination**

The requirements for robustness of termination testing are specified in Section 9 of ESA/SCC Generic Specification No. 3702. The test conditions shall be as follows:-

(a) Test Ua1: "Tensile", applied in the axis of the terminals, Force : 20N

4.4. MATERIALS AND FINISHES

The materials and finishes shall be as specified herein. Where a definite material is not specified, a material which will enable the switches specified herein to meet the performance requirements of this specification shall be used. Acceptance or approval of any constituent material does not guarantee acceptance of the finished product.

4.4.1 Case

Nickel-iron alloy, with electroless nickel plating, welded construction. Neither electro-deposited tin nor any paint shall be used.

4.4.2 Terminals

The terminal material shall be Type 'D' with Type '3' finish in accordance with the requirements of ESA/SCC Basic Specification No. 23500.

4.5 MARKING

4.5.1 General

The marking of all components delivered to this specification shall be in accordance with with the requirements of ESA/SCC Basic Specification No. 21700 and the following paragraphs. When the component is too small to accommodate all of the marking specified, as much as space permits shall be marked and the marking information, in full, shall accompany the component in its primary package.

The information to be marked and the order of precedence, shall be as follows:-

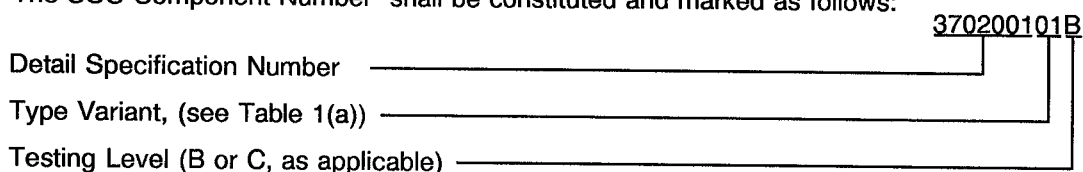
- (a) The SCC Component Number.
- (b) Temperature Characteristics.
- (c) Traceability Information.

4.5.2 Terminal Identification

Not applicable.

4.5.3 The SCC Component Number

The SCC Component Number shall be constituted and marked as follows:

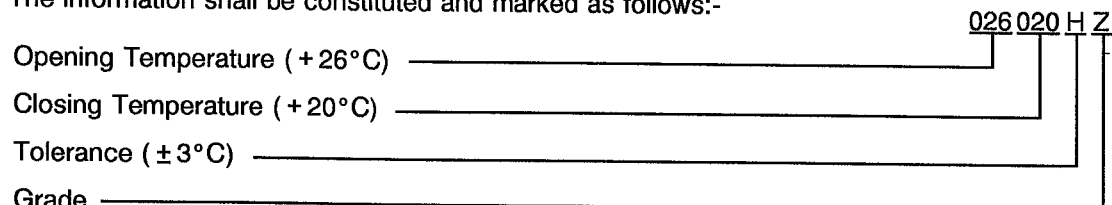


4.5.4 Temperature Characteristics

The temperature characteristics and ratings to be marked in the following order of precedence are:-

- (a) Opening Temperature (TNf).
- (b) Closing Temperature (TNr).
- (c) Tolerance.
- (d) Grade.

The information shall be constituted and marked as follows:-





4.5.4.1 Temperatures

The opening and closing temperatures shall be written in clear and each temperature shall be comprised of 3 digits.

For negative temperatures the first digit shall be "6".

4.5.4.2 Tolerance

The tolerance on nominal operating temperatures shall be indicated by the code letters specified hereafter.

TOLERANCE (± °C)	CODE LETTER
3.0	H
5.0	J
None	X

4.5.4.3 Grade

The grade of thermostat characteristics shall be indicated by the code letters specified hereafter.

GRADE	CODE LETTER
1	None
Y	Y
Z	Z

4.5.5 Traceability Information

Each component shall be marked in respect of traceability information in accordance with the requirements of ESA/SCC Basic Specification No. 21700.

4.6 ELECTRICAL MEASUREMENTS

4.6.1 Electrical and Thermal Measurements

The parameters to be measured are scheduled in Table 2.

4.6.2 Electrical Measurements at High and Low Temperatures

Not applicable.

4.7 RUN-IN

4.7.1 Measurements During Run-in

Not applicable.

4.7.2 Conditions for Run-in

The requirements for run-in are specified in Section 7 of the ESA/SCC Generic Specification No. 3702. The conditions for run-in shall be as specified in Table 5(a) of this specification.

4.7.3 Electrical Circuits for Run-in

Not applicable.

**TABLE 2 - ELECTRICAL AND THERMAL MEASUREMENTS**

No	CHARACTERISTICS	SYMBOL	ESA/SCC 3702 TEST METHOD	TEST CONDITION	LIMITS		UNIT
					MIN	MAX	
1	Voltage Proof at $T \geq T_2$ (1)	V	Para.9.5.1.1	Between contacts and ground	1000	-	Vrms
				Between open contacts	100	-	Vrms
2	Insulation Resistance at $T \geq T_2$ (1)	Ri	Para.9.5.1.2	Test Voltage 100Vdc	500	-	M $\Omega$
				Between contacts and ground			
	Between open contacts						
3	Contact Resistance at $T \leq T_3$ (1)	Rc	Para.9.5.1.3		-	50	m $\Omega$
4	Operating Temperature	Tf	Para. 9.5.1.4	Para. 9.5.1.4 (Note 2)	See Table 1(a)		$^{\circ}$ C
5	Restoring Temperature	Tr	Para. 9.5.1.4	Para. 9.5.1.4 (Note 2)	See Table 1(a)		$^{\circ}$ C
6	Tf - Tr	-	-	-	See Table 1(a)		$^{\circ}$ C

**NOTES**

1. T1, T2, T3, T4 as defined in ESA/SCC Generic Specification No. 3702, Para. 9.5.1.
2. Temperature gradient for measurements :  $\frac{1}{3}^{\circ}$ C/minute minimum.  
: 1.0 $^{\circ}$ C/minute maximum.

**TABLE 3 - ELECTRICAL MEASUREMENTS AT HIGH AND LOW TEMPERATURES**

Not applicable.



**TABLE 4 - PARAMETER DRIFT VALUES**

No	CHARACTERISTICS	SYMBOL	SPEC AND/OR TEST METHOD	TEST CONDITIONS	CHANGE LIMITS ( $\Delta$ )	UNIT
4	Operating Temperature	Tf	As per Table 2	As per Table 2	$\pm 1.0$	$^{\circ}\text{C}$
5	Restoring Temperature	Tr	As per Table 2	As per Table 2	$\pm 1.0$	$^{\circ}\text{C}$

**TABLE 5(a) - CONDITIONS FOR RUN-IN**


No	CHARACTERISTICS	SYMBOL	ESA/SCC 3702 TEST METHOD	TEST CONDITIONS	UNIT
1	Temperature	T	Para 9.7	$T_3 \rightarrow T_2$ $T_2 \rightarrow T_3$ (1)	$^{\circ}\text{C}$

**NOTES**

1. T2 and T3 as defined in ESA/SCC Generic Specification No. 3702, Para. 9.5.1.

**TABLE 5(b) - CONDITIONS FOR OPERATING LIFE TEST**

No	CHARACTERISTICS	SYMBOL	CONDITIONS	UNIT
1	Temperature	T	$T_2 \leq T \leq T_{Nf} + 30$	$^{\circ}\text{C}$
2	Temperature	T	$T_{Nr} - 30 \leq T \leq T_3$	$^{\circ}\text{C}$
3	Contact Load Resistive	V	30	V
		I	4.0	A

	<p style="text-align: center;">ESA/SCC Detail Specification No. 3702/001</p>	<p>PAGE 16 ISSUE 4</p>
--	--	----------------------------

4.8 ENVIRONMENTAL AND ENDURANCE TESTING (Charts IV and V of ESA/SCC Generic Specification No. 3702)

4.8.1 Measurements and Inspections on Completion of Environmental Tests

The parameters to be measured and inspections to be performed on completion of environmental tests are scheduled in Table 6.

4.8.2 Measurements and Inspections during Endurance Tests

The parameters to be measured and inspections to be performed during endurance tests are scheduled in Table 6. The measurements shall be performed at the applicable test temperature.

4.8.3 Measurements and Inspections on Completion of Endurance Tests

The parameters to be measured and inspections to be performed on completion of the endurance tests are scheduled in Table 6.

4.8.4 Conditions for Operating Life Test (Part of Endurance Testing)

The requirements for operating life testing are specified in Section 9 of ESA/SCC Generic Specification No. 3702. The conditions for operating life testing shall be as specified in Table 5(b) of this specification.

4.8.5 Electrical Circuits for Operating Life Testing

Not applicable.



**TABLE 6 - MEASUREMENTS AND INSPECTIONS ON COMPLETION OF ENVIRONMENTAL TESTS AND AT INTERMEDIATE POINTS AND ON COMPLETION OF ENDURANCE TESTING**

No	ESA/SCC GEN.SPEC.NO. 3702		MEASUREMENTS AND INSPECTIONS		SYMBOL	LIMITS		UNIT
	ENVIRONMENTAL AND ENDURANCE TESTS (1)	TEST METHOD AND CONDITIONS	IDENTIFICATION	CONDITIONS		MIN	MAX	
01	Seal Test	Para 9 2	Seal Test	Fine leak Gross leak	- -	- 1.10-8 No Bubbles		atm/cc/s
02	External Visual Inspection	Para 9 3	External Visual Inspection	-	-	-	-	
03	Creepage	Para 9 6	Creepage	Para. 9.6	-	No Creepage		
04	Response Time	Para 9 8	Response Time	Para. 9.8	trp	-	20	s
05	Rapid Change of Temperature	Para 9.9	Last cycle: Electrical Measurements Visual Examination	Table 2 Items 1, 2, 3 -	- -	Table 2 Items 1, 2, 3 -		
06	Vibration	Para 9 10	Visual Examination	-	-	-	-	
07	Shock	Para 9.11	Visual Examination Electrical Measurements Thermal Measurements	- Table 2 Items 1, 2, 3 Table 2 Items 4, 5	- - $\Delta T_f/\Delta T_r$	- Table 2 Items 1, 2, 3 +2.7	-	$^{\circ}\text{C}$
08	Robustness of Terminations	Para 9.12 and Paras. 4.2 4 and 4 2.5 of this spec	Visual Examination	-	-	-	-	
09	Permanence of Marking	Para 9.13	Visual Examination	-	-	-	-	
10	Resistance to Soldering Heat	Para 9 14	Visual Examination Thermal Measurements	- Table 2 Items 4, 5	- $\Delta T_f/\Delta T_r$	- -1.7	- +1.7	$^{\circ}\text{C}$
11	Damp Heat (Steady State)	Para 9.15		-	-	-	-	
12	Overload	Para 9.16 Res 6A & 30Vdc	Electrical Measurements Thermal Measurements External Visual Inspection	Table 2 Item 3 Table 2 Items 4, 5 Para 9 2 of Gen 3702	- $\Delta T_f/\Delta T_r$ -	Table 2 Item 3 -1.7 -	+1.7 -	$^{\circ}\text{C}$
13	Operating Life Resistive	Para 9.17 Table 5(b) of this spec	Electrical Measurements Thermal Measurements Visual Examination	Table 2 Items 1,2 Table 2 Item 3 Table 2 Items 4, 5 -	- - $\Delta T_f/\Delta T_r$ -	Table 2 Items 1, 2 - -1.7	100 +1.7 -	m $\Omega$ $^{\circ}\text{C}$
14	Solderability	Para 9 18 and Paras. 4 2.4 and 4.2 5 of this spec	Visual Examination	-	-	-	-	
15	High Temperature Storage	Para 9 19 Zero dissipation		After < 96 hours recovery Table 2 Items 1,2,3 Table 2 Items 4, 5	- $\Delta T_f/\Delta T_r$	Table 2 Items 1, 2, 3 -1.7	+1.7	$^{\circ}\text{C}$
16	Low Temperature Storage	Para 9 20 Not used						
17	Salt Mist	Para 9 21	Visual Examination	-	-	-	-	
18	Electrical and Thermal Measurements	Para 9 5.4	Electrical Measurements Thermal Measurements	Table 2 Items 1, 2, 3 Table 2 Items 4, 5, 6	- -	Table 2 Items 1, 2, 3, Table 2 Items 4, 5, 6		

**NOTES** 1. The tests in this Table refer to either Chart IV or V and shall be used as applicable.