



TRANSISTORS, HIGH POWER, NPN
BASED ON TYPE BUR14
ESCC Detail Specification No. 5203/030

ISSUE 1
October 2002



	ESCC Detail Specification		PAGE ii ISSUE 1
---	---------------------------	--	--------------------

LEGAL DISCLAIMER AND COPYRIGHT

European Space Agency, Copyright © 2002. All rights reserved.

The European Space Agency disclaims any liability or responsibility, to any person or entity, with respect to any loss or damage caused, or alleged to be caused, directly or indirectly by the use and application of this ESCC publication.

This publication, without the prior permission of the European Space Agency and provided that it is not used for a commercial purpose, may be:

- copied in whole in any medium without alteration or modification.
- copied in part, in any medium, provided that the ESCC document identification, comprising the ESCC symbol, document number and document issue, is removed.



european space agency
agence spatiale européenne

Pages 1 to 19

TRANSISTORS, HIGH POWER, NPN,

BASED ON TYPE BUR 14

ESA/SCC Detail Specification No. 5203/030

SCC

**space components
coordination group**

Issue/Rev.	Date	Approved by	
		SCCG Chairman	ESA Director General or his Deputy
Issue 1	June 1983		
Revision 'A'	February 1992	<i>Pommes</i>	<i>J. Lopez</i>
Revision 'B'	July 1993	<i>Pommes</i>	<i>F. Dub</i>
Revision 'C'	August 1996	<i>Sam Miller</i>	<i>C. Horn</i>



DOCUMENTATION CHANGE NOTICE

Rev. Letter	Rev. Date	Reference	CHANGE Item	Approved DCR No.
		This Issue incorporates all modifications agreed on the basis of Policy DCR's 21019, 21021, 21022 and 21025.		
'A'	Feb. '92	P1. Cover page P2. DCN P5. Para. 1.2 Para. 2 P6. Table 1(a) P10. Para. 4.2.2 Para. 4.2.3 Para. 4.2.4 P16. Table 3	: Paragraph amended : "ESA/SCC Basic Spec. No. 23500" added : "Lead Material and/or Finish" column added : Bond Strength and Die Shear Test deviations deleted : PIND deviation deleted : Radiographic Inspection deviation deleted : Bond Strength and Die Shear Test deviations deleted : Note deleted	None None 21021 21025 21025 23499 21043 21049 23499 21047
'B'	Jul. '93	P1. Cover page P2. DCN P11. Para. 4.3.2	: Maximum weight amended to 1.20g	None None 23560
		This document has been transferred from hardcopy to electronic format. The content is unchanged but minor differences in presentation exist.		
'C'	Aug. '96	P1. Cover page P2. DCN P11. Para. 4.3.3 P12. Para. 4.5.3	: Applied Force deleted : Component Number corrected	None None 221332 23828

**SCC**ESA/SCC Detail Specification
No. 5203/030

PAGE 3

ISSUE 1

TABLE OF CONTENTS

	<u>Page</u>
1. <u>GENERAL</u>	5
1.1 Scope	5
1.2 Component Type Variants	5
1.3 Maximum Ratings	5
1.4 Parameter Derating Information	5
1.5 Physical Dimensions	5
1.6 Functional Diagram	5
2. <u>APPLICABLE DOCUMENTS</u>	5
3. <u>TERMS, DEFINITIONS, ABBREVIATIONS, SYMBOLS AND UNITS</u>	10
4. <u>REQUIREMENTS</u>	10
4.1 General	10
4.2 Deviations from Generic Specification	10
4.2.1 Deviations from Special In-process Controls	10
4.2.2 Deviations from Final Production Tests (Chart II)	10
4.2.3 Deviations from Burn-in and Electrical Measurements (Chart III)	10
4.2.4 Deviations from Qualification Tests (Chart IV)	10
4.2.5 Deviations from Lot Acceptance Tests (Chart V)	11
4.3 Mechanical Requirements	11
4.3.1 Dimension Check	11
4.3.2 Weight	11
4.3.3 Terminal Strength	11
4.4 Materials and Finishes	11
4.4.1 Case	11
4.4.2 Lead Material and Finish	11
4.5 Marking	12
4.5.1 General	12
4.5.2 Lead Identification	12
4.5.3 The SCC Component Number	12
4.5.4 Traceability Information	12
4.5.5 Marking of Small Components	12



	<u>Page</u>
4.6 Electrical Measurements	13
4.6.1 Electrical Measurements at Room Temperature	13
4.6.2 Electrical Measurements at High and Low Temperatures	13
4.6.3 Circuits for Electrical Measurements	13
4.7 Burn-in Tests	13
4.7.1 Parameter Drift Values	13
4.7.2 Conditions for Burn-in	13
4.7.3 Electrical Circuits for Burn-in	13
4.8 Environmental and Endurance Tests	18
4.8.1 Electrical Measurements on Completion of Environmental Tests	18
4.8.2 Electrical Measurements at Intermediate Points and on Completion of Endurance Tests	18
4.8.3 Conditions for Operating Life Tests (Part of Endurance Testing)	18
4.8.4 Electrical Circuits for Operating Life Tests	18
4.8.5 Conditions for High Temperature Storage Test (Part of Endurance Testing)	18

TABLES

1(a) Type Variants	6
1(b) Maximum Ratings	6
2 Electrical Measurements at Room Temperature - d.c. Parameters	14
Electrical Measurements at Room Temperature - a.c. Parameters	15
3 Electrical Measurements at High and Low Temperatures	16
4 Parameter Drift Values	16
5 Conditions for Burn-in	17
6 Electrical Measurements at Intermediate Points and on Completion of Endurance Testing	19

FIGURES

1 Parameter Derating Information	7
2 Physical Dimensions	8
3 Functional Diagram	9
4 Test Circuit	N/A
5 Electrical Circuit for Burn-in	17

APPENDICES (Applicable to specific Manufacturers only)

None.

**1. GENERAL****1.1 SCOPE**

This specification details the ratings, physical and electrical characteristics, test and inspection data for a Transistor, High Power, NPN, based on Type BUR14.

It shall be read in conjunction with ESA/SCC Generic Specification No. 5000, the requirements of which are supplemented herein.

1.2 COMPONENT TYPE VARIANTS

See Table 1(a).

1.3 MAXIMUM RATINGS

The maximum ratings, which shall not be exceeded at any time during use or storage, applicable to the transistors specified herein, are scheduled in Table 1(b).

1.4 PARAMETER DERATING INFORMATION

The derating information applicable to the transistors specified herein is shown in Figure 1.

1.5 PHYSICAL DIMENSIONS

The physical dimensions of the transistors specified herein are shown in Figure 2.

1.6 FUNCTIONAL DIAGRAM

The functional diagram showing lead identification, of the transistors specified herein, is shown in Figure 3.

2. APPLICABLE DOCUMENTS

The following documents form part of this specification and shall be read in conjunction with it:-

- (a) ESA/SCC Generic Specification No. 5000 for Discrete Semiconductor Components.
- (b) MIL-STD-750, Test Methods and Procedures for Semiconductor Devices.
- (c) ESA/SCC Basic Specification No. 23500, Requirements for Lead Materials and Finishes for Components for Space Application.



TABLE 1(a) - TYPE VARIANTS

VARIANT	BASED ON TYPE	CASE	FIGURE	LEAD MATERIAL AND FINISH
01	BUR14	TO39	2	D2

TABLE 1(b) - MAXIMUM RATINGS

No.	CHARACTERISTICS	SYMBOL	MAXIMUM RATINGS	UNIT	REMARKS
1	Collector-Base Breakdown Voltage	$V_{(BR)CBO}$	150	V	
2	Collector-Emitter Breakdown Voltage	$V_{(BR)CEO}$	120	V	
3	Emitter-Base Breakdown Voltage	$V_{(BR)EBO}$	5.5	V	
4	Collector Current	I_C	3.0	A	
5	Power Dissipation	P_{tot}	1.0	W	At $T_{amb} \leq +25^\circ C$ For derating, see Figure 1
6	Operating Temperature Range	T_{op}	- 65 to +200	$^\circ C$	T_{amb}
7	Storage Temperature Range	T_{stg}	- 65 to +200	$^\circ C$	
8	Soldering Temperature	T_{sol}	+ 300	$^\circ C$	Time: $\leq 60s$ Distance from case $\geq 1.5mm$
9	Power Dissipation	P_{tot}	7.0	W	At $T_{case} = +25^\circ C$
10	Collector Current (Peak)	I_{CM}	5.0	A	



FIGURE 1 - PARAMETER DERATING INFORMATION

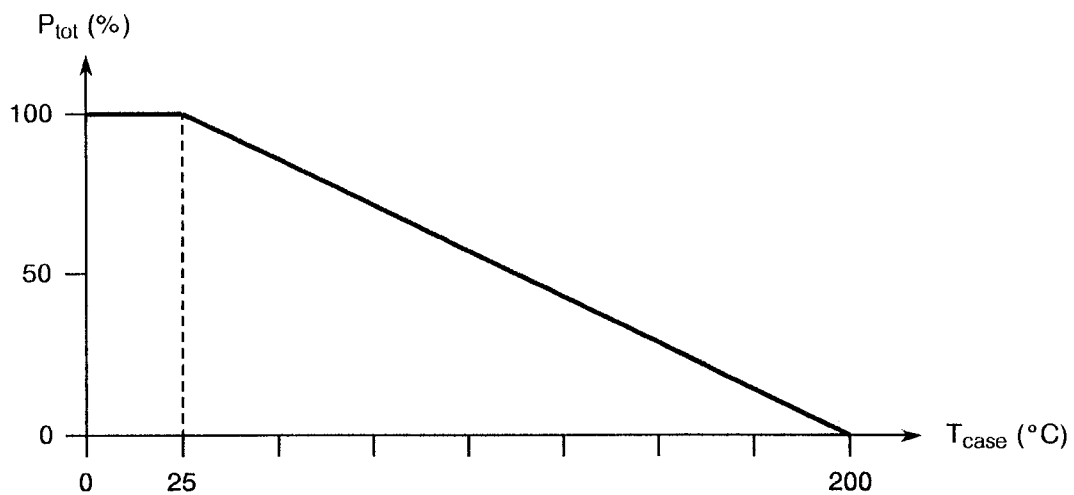

Power Dissipation versus Temperature



FIGURE 2 - PHYSICAL DIMENSIONS

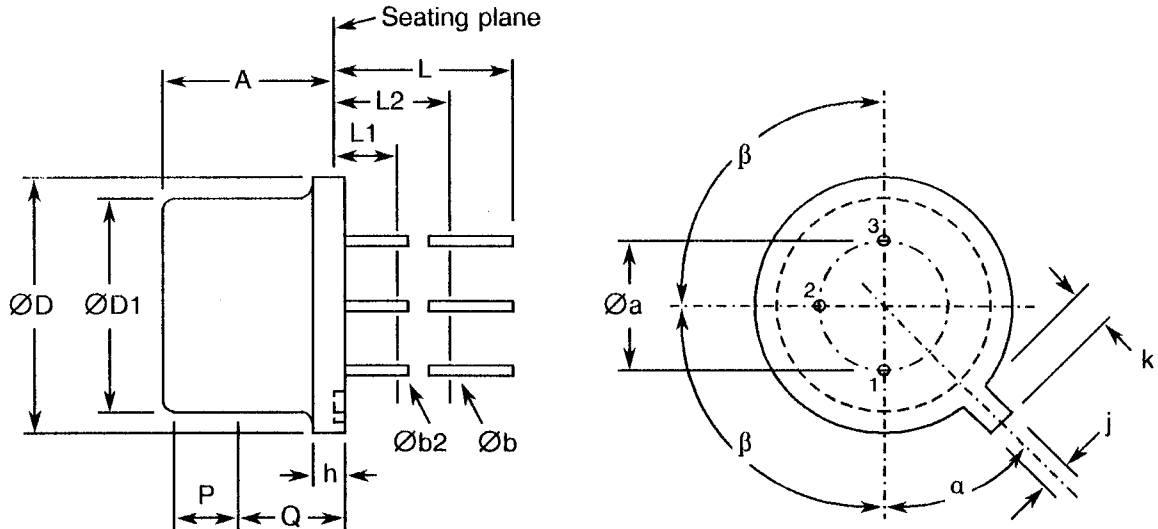

SYMBOL	INCHES		MILLIMETRES		NOTES
	MIN.	MAX.	MIN.	MAX.	
Øa	0.190	0.210	4.83	5.33	
A	0.240	0.260	6.10	6.60	
Øb	0.016	0.021	0.406	0.533	2
Øb2	0.016	0.019	0.406	0.483	2
ØD	0.350	0.370	8.89	9.40	
ØD1	0.315	0.335	8.00	8.51	
h	0.009	0.125	0.229	3.18	
j	0.028	0.034	0.711	0.864	
k	0.029	0.040	0.737	1.02	3
L	0.500	-	12.70	-	2
L1	-	0.050	-	1.27	2
L2	0.250	-	6.35	-	2
P	0.100	-	2.54	-	1
Q	-	-	-	-	4
α	45° NOM.				
β	90° NOM.				

NOTES

1. This zone is controlled for automatic handling. The variation in actual diameter within this zone shall not exceed 0.010 inch (0.254mm).
2. (3 leads) Øb2 applies between L1 and L2. Øb applies between L2 and 0.5 inch (12.70mm) from the seating plane. Diameter is uncontrolled in L1 and beyond 0.5 inch (12.70mm) from the seating plane.
3. Measured from maximum diameter of the actual device.
4. Details of outline in this zone is optional.



FIGURE 3 - FUNCTIONAL DIAGRAM

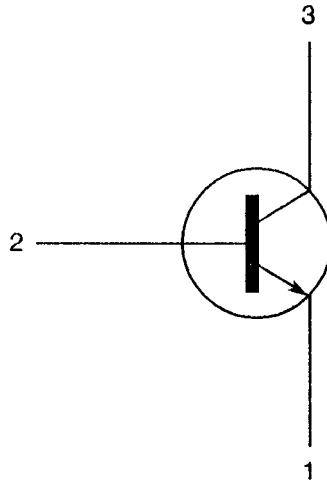

NOTES

1. The collector is internally connected to the case.

**3. TERMS, DEFINITIONS, ABBREVIATIONS, SYMBOLS AND UNITS**

For the purpose of this specification, the terms, definitions, abbreviations, symbols and units specified in ESA/SCC Basic Specification No. 21300 shall apply.

4. REQUIREMENTS**4.1 GENERAL**

The complete requirements for procurement of the transistors specified herein are stated in this specification and ESA/SCC Generic Specification No. 5000. Deviations from the Generic Specification, applicable to this specification only, are listed in Para. 4.2.

Deviations from the applicable Generic Specification and this Detail Specification, formally agreed with specific Manufacturers on the basis that the alternative requirements are equivalent to the ESA/SCC requirements and do not affect the components' reliability, are listed in the appendices attached to this specification.

4.2 DEVIATIONS FROM GENERIC SPECIFICATION**4.2.1 Deviations from Special In-process Controls**

None.

4.2.2 Deviations from Final Production Tests (Chart II)

None.

4.2.3 Deviations from Burn-in and Electrical Measurements (Chart III)

(a) H.T.R.B. test: Shall not be performed.

4.2.4 Deviations from Qualification Tests (Chart IV)

None.



4.2.5 Deviations from Lot Acceptance Tests (Chart V)

None.

4.3 MECHANICAL REQUIREMENTS

4.3.1 Dimension Check

The dimensions of the transistors specified herein shall be checked. They shall conform to those shown in Figure 2.

4.3.2 Weight

The maximum weight of the transistors specified herein shall be 1.2 grammes.

4.3.3 Terminal Strength

The requirements for terminal strength testing are specified in Section 9 of ESA/SCC Generic Specification No. 5000. The test conditions shall be as follows:-

Test Condition: 'E', Lead Fatigue.

4.4 MATERIALS AND FINISHES

The materials and finishes shall be as specified herein. Where a definite material is not specified, a material which will enable the transistors specified herein to meet the performance requirements of this specification shall be used. Acceptance or approval of any constituent material does not guarantee acceptance of the finished product.

4.4.1 Case

Metal case, hermetically sealed, similar to JEDEC TO-39.

4.4.2 Lead Material and Finish

The lead material shall be Type 'D' with Type '2' finish in accordance with the requirements of ESA/SCC Basic Specification No. 23500.



4.5 MARKING

4.5.1 General

The marking of all components delivered to this specification shall be in accordance with the requirements of ESA/SCC Basic Specification No. 21700. Each component shall be marked in respect of:-

- (a) Lead Identification.
- (b) The SCC Component Number.
- (c) Traceability Information.

4.5.2 Lead Identification

Lead identification shall be as shown in Figures 2 and 3.

4.5.3 The SCC Component Number

Each component shall bear the SCC Component Number which shall be constituted and marked as follows:-

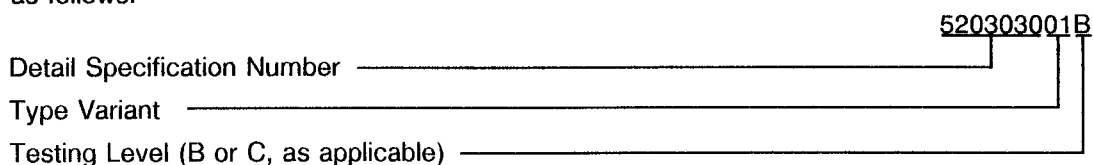

4.5.4 Traceability Information

Each component shall be marked in respect of traceability information in accordance with the requirements of ESA/SCC Basic Specification No. 21700.

4.5.5 Marking of Small Components

When it is considered that the component is too small to accommodate the marking as specified above, as much as space permits shall be marked. The order of precedence shall be as follows:-

- (a) Lead Identification.
- (b) The SCC Component Number.
- (c) Traceability Information.

The marking information in full shall accompany each component in its primary package.



4.6 ELECTRICAL MEASUREMENTS

4.6.1 Electrical Measurements at Room Temperature

The parameters to be measured at room temperature are scheduled in Table 2. Unless otherwise specified, measurements shall be performed at $T_{amb} = +22 \pm 3$ °C.

4.6.2 Electrical Measurements at High and Low Temperatures

The parameters to be measured at high and low temperatures are scheduled in Table 3.

4.6.3 Circuits for Electrical Measurements

Circuits for use in performing the electrical measurements listed in Tables 2 and 3 of this specification are shown in Figure 4.

4.7 BURN-IN TESTS

4.7.1 Parameter Drift Values

The parameter drift values applicable to burn-in are specified in Table 4 of this specification. Unless otherwise stated, measurements shall be performed at $T_{amb} = +22 \pm 3$ °C. The parameter drift values (Δ) applicable to the parameters scheduled shall not be exceeded. In addition to these drift value requirements, the appropriate limit value specified for a given parameter in Table 2 shall not be exceeded.

4.7.2 Conditions for Burn-in

The requirements for burn-in are specified in Section 7 of ESA/SCC Generic Specification No. 5000. The conditions for burn-in shall be as specified in Table 5 of this specification.

4.7.3 Electrical Circuits for Burn-in

Circuits for use in performing the burn-in tests are shown in Figure 5 of this specification.



TABLE 2 - ELECTRICAL MEASUREMENTS AT ROOM TEMPERATURE - d.c. PARAMETERS

No.	CHARACTERISTICS	SYMBOL	MIL-STD-750 TEST METHOD	TEST CONDITIONS	LIMITS		UNIT
					MIN	MAX	
1	Collector-Emitter Breakdown Voltage	$V_{(BR)CEO}$	3011	$I_C = 20mA$ $I_B = 0A$ Note 1	120	-	V
2	Emitter-Base Breakdown Voltage	$V_{(BR)EBO}$	3026	$I_E = 1.0mA$ $I_C = 0A$	5.5	-	V
3	Collector-Emitter Cut-off Current	I_{CES}	3041	$V_{CE} = 100V$ $V_{BE} = 0V$	-	1.0	μA
				$V_{CE} = 150V$ $V_{BE} = 0V$	-	100	
4	Emitter-Base Cut-off Current	I_{EBO}	3061	$V_{EB} = 4.0V$ $I_C = 0A$	-	1.0	μA
5	D.C. Forward Current Transfer Ratio	h_{FE1}	3076	$I_C = 50mA$ $V_{CE} = 5.0V$ Note 1	50	-	-
		h_{FE2}		$I_C = 250mA$ $V_{CE} = 5.0V$ Note 1	70	-	
		h_{FE3}		$I_C = 1.0A$ $V_{CE} = 5.0V$ Note 1	70	200	
		h_{FE4}		$I_C = 2.5A$ $V_{CE} = 5.0V$ Note 1	20	-	
6	Collector Saturation Voltage	V_{CEsat}	3071	$I_C = 1.0A$ $I_B = 0.1A$ Notes 1 and 2	-	0.5	V
				$I_C = 2.5A$ $I_B = 0.25A$ Notes 1 and 2	-	1.0	
7	Base Saturation Voltage	V_{BEsat}	3066	$I_C = 1.0A$ $I_B = 0.1A$ Notes 1 and 2	-	1.1	V
				$I_C = 2.5A$ $I_B = 0.25A$ Notes 1 and 2	-	1.5	

NOTES

1. Pulsed measurement: Pulse Width $\leq 300\mu s$, Duty Cycle $\leq 2.0\%$.
2. Saturation voltages measured 6.0mm from header.

**TABLE 2 - ELECTRICAL MEASUREMENTS AT ROOM TEMPERATURE - a.c. PARAMETERS**

No.	CHARACTERISTICS	SYMBOL	MIL-STD-750 TEST METHOD	TEST CONDITIONS	LIMITS		UNIT
					MIN	MAX	
1	A.C. Forward Current Transfer Ratio	h_{fe}	3206	$I_C = 0.1A$ $V_{CE} = 5.0V$ $f = 20MHz$	2.0	-	-
2	Output Capacitance	C_{obo}	3236	$V_{CB} = 20V$ $I_C = 0A$ $f = 1.0MHz$	-	50	pF
3	Turn-on Time	t_{on}	-	$I_C = 1.0A$ $I_{B1} = 0.1A$ $I_{B2} = -0.1A$ $V_{CC} = 20V$	-	0.5	μs
	Turn-off Time	t_{off}			-	2.3	

FIGURE 4 - TEST CIRCUIT

Not applicable.

**TABLE 3 - ELECTRICAL MEASUREMENTS AT HIGH AND LOW TEMPERATURES**

No.	CHARACTERISTICS	SYMBOL	MIL-STD-750 TEST METHOD	TEST CONDITIONS	LIMITS		UNIT
					MIN	MAX	
1	Collector-Emitter Cut-off Current	I_{CES}	3041	$T_{amb} = +150^{\circ}C$ $V_{CE} = 100V$ $V_{BE} = 0V$	-	10	μA
2	D.C. Forward Current Transfer Ratio	h_{FE}	3076	$T_{amb} = -55^{\circ}C$ $I_C = 1.0A$ $V_{CE} = 5.0V$ Note 1	35	-	-

NOTES

1. Pulsed measurement: Pulse Width $\leq 300\mu s$, Duty Cycle $\leq 2.0\%$.

TABLE 4 - PARAMETER DRIFT VALUES

No.	CHARACTERISTICS	SYMBOL	MIL-STD-750 TEST METHOD	TEST CONDITIONS	CHANGE LIMITS (Δ)	UNIT
1	Emitter-Base Cut-off Current	I_{EBO}	3061	$V_{EB} = 4.0V$ $I_C = 0A$	± 200	nA
2	D.C. Forward Current Transfer Ratio	h_{FE}	3076	$V_{CE} = 5.0V$ $I_C = 1.0A$ Note 1	± 25	%
3	Collector Saturation Voltage	V_{CEsat}	3071	$I_C = 2.5A$ $I_B = 0.25A$ Note 1	± 100	mV

NOTES

1. Pulsed measurement: Pulse Width $\leq 300\mu s$, Duty Cycle $\leq 2.0\%$.



TABLE 5 - CONDITIONS FOR BURN-IN

No.	CHARACTERISTICS	SYMBOL	CONDITIONS	UNIT
1	Ambient Temperature	T_{amb}	$+ 25 \pm 3$	$^{\circ}C$
2	Collector-Emitter Voltage	V_{CE}	20	V
3	Power Dissipation	P_{tot}	1.0	W

NOTES

1. No heatsink forced air directly on the device shall be permitted.

FIGURE 5 - ELECTRICAL CIRCUIT FOR BURN-IN

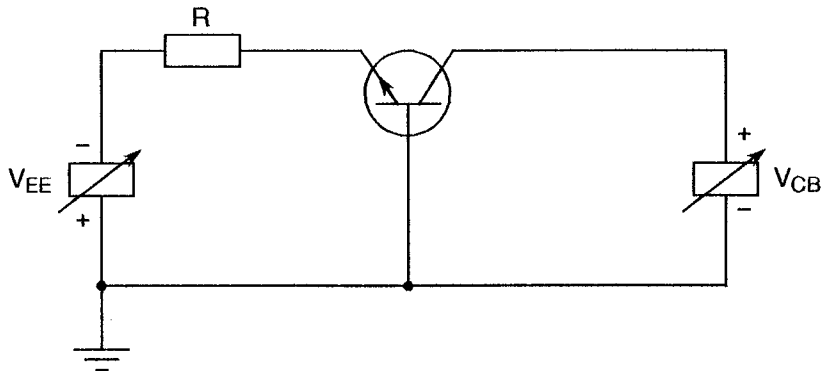



- 4.8 ENVIRONMENTAL AND ENDURANCE TESTS (CHARTS IV AND V OF ESA/SCC GENERIC SPECIFICATION NO. 5000)
- 4.8.1 Electrical Measurements on Completion of Environmental Tests
The parameters to be measured on completion of environmental tests are scheduled in Table 2. The measurements shall be performed at $T_{amb} = +22 \pm 3$ °C.
- 4.8.2 Electrical Measurements at Intermediate Points and on Completion of Endurance Tests
The parameters to be measured at intermediate points and on completion of endurance testing are scheduled in Table 6 of this specification.
- 4.8.3 Conditions for Operating Life Tests (Part of Endurance Testing)
The requirements for operating life testing are specified in Section 9 of ESA/SCC Generic Specification No. 5000. The conditions for operating life testing shall be the same as specified in Table 5 for the burn-in test.
- 4.8.4 Electrical Circuits for Operating Life Tests
The circuit to be used for performing the operating life tests shall be the same as that shown in Figure 5 for burn-in.
- 4.8.5 Conditions for High Temperature Storage Test (Part of Endurance Testing)
The requirements for the high temperature storage test are specified in ESA/SCC Generic Specification No. 5000. The temperature to be applied shall be the maximum storage temperature specified in Table 1(b) of this specification.



TABLE 6 - ELECTRICAL MEASUREMENTS AT INTERMEDIATE POINTS AND ON COMPLETION OF ENDURANCE TESTING

No.	CHARACTERISTICS	SYMBOL	MIL-STD-750 TEST METHOD	TEST CONDITIONS	LIMITS		UNIT
					MIN.	MAX.	
3	Collector-Emitter Cut-off Current	I_{CES}	3041	$V_{BE} = 0V$ $V_{CE} = 100V$	-	1.0	μA
5	D.C. Forward Current Transfer Ratio 3	h_{FE3}	3076	$I_C = 1.0A$ $V_{CE} = 5.0V$ Note 1	70	200	-
6	Collector-Emitter Saturation Voltage	V_{CEsat}	3071	$I_C = 2.5A$ $I_B = 0.25A$ Notes 1 and 2	-	1.0	V

NOTES

1. Pulsed measurement: Pulse Width $\leq 300\mu s$, Duty Cycle $\leq 2.0\%$.
2. Saturation voltages measured 6.0mm from header.