



**INTEGRATED CIRCUITS, SILICON MONOLITHIC,
HCMOS DUAL POSITIVE OR NEGATIVE EDGE
SCHMITT-RETRIGGERABLE MONOSTABLE
MULTIVIBRATORS WITH CLEAR RESET,
BASED ON TYPE 54HC4538
ESCC Detail Specification No. 9207/008**

**ISSUE 1
October 2002**



| | | | |
|---|---------------------------|--|--------------------|
|  | ESCC Detail Specification | | PAGE ii ISSUE 1 |
|---|---------------------------|--|--------------------|

LEGAL DISCLAIMER AND COPYRIGHT

European Space Agency, Copyright © 2002. All rights reserved.

The European Space Agency disclaims any liability or responsibility, to any person or entity, with respect to any loss or damage caused, or alleged to be caused, directly or indirectly by the use and application of this ESCC publication.

This publication, without the prior permission of the European Space Agency and provided that it is not used for a commercial purpose, may be:

- copied in whole in any medium without alteration or modification.
- copied in part, in any medium, provided that the ESCC document identification, comprising the ESCC symbol, document number and document issue, is removed.



european space agency
agence spatiale européenne

Pages 1 to 40

**INTEGRATED CIRCUITS, SILICON MONOLITHIC,
HCMOS DUAL POSITIVE OR NEGATIVE EDGE
SCHMITT-RETRIGGERABLE MONOSTABLE
MULTIVIBRATORS WITH CLEAR RESET,
BASED ON TYPE 54HC4538**

ESA/SCC Detail Specification No. 9207/008





**space components
coordination group**

| Issue/Rev. | Date | Approved by | |
|--------------|--------------|---------------|---------------------------------------|
| | | SCCG Chairman | ESA Director General or his Deputy |
| Issue 1 | October 1992 | | |
| Revision 'A' | May 1994 | | |
| Revision 'B' | June 1995 | | |
| Revision 'C' | January 2002 | | |

TABLE OF CONTENTS

| | | <u>Page</u> |
|-------|---|-------------|
| 1. | <u>GENERAL</u> | 5 |
| 1.1 | Scope | 5 |
| 1.2 | Component Type Variants | 5 |
| 1.3 | Maximum Ratings | 5 |
| 1.4 | Parameter Derating Information | 5 |
| 1.5 | Physical Dimensions | 5 |
| 1.6 | Pin Assignment | 5 |
| 1.7 | Truth Table | 5 |
| 1.8 | Circuit Schematic | 5 |
| 1.9 | Functional Diagram | 5 |
| 1.10 | Handling Precautions | 5 |
| 1.11 | Input and Output Protection Networks | 5 |
| 2. | <u>APPLICABLE DOCUMENTS</u> | 14 |
| 3. | <u>TERMS, DEFINITIONS, ABBREVIATIONS, SYMBOLS AND UNITS</u> | 14 |
| 4. | <u>REQUIREMENTS</u> | 14 |
| 4.1 | General | 14 |
| 4.2 | Deviations from Generic Specification | 14 |
| 4.2.1 | Deviations from Special In-process Controls | 14 |
| 4.2.2 | Deviations from Final Production Tests | 14 |
| 4.2.3 | Deviations from Burn-in Tests | 14 |
| 4.2.4 | Deviations from Qualification Tests | 14 |
| 4.2.5 | Deviations from Lot Acceptance Tests | 15 |
| 4.3 | Mechanical Requirements | 15 |
| 4.3.1 | Dimension Check | 15 |
| 4.3.2 | Weight | 15 |
| 4.4 | Materials and Finishes | 15 |
| 4.4.1 | Case | 15 |
| 4.4.2 | Lead Material and Finish | 15 |
| 4.5 | Marking | 15 |
| 4.5.1 | General | 15 |
| 4.5.2 | Lead Identification | 15 |
| 4.5.3 | The SCC Component Number | 16 |
| 4.5.4 | Traceability Information | 16 |
| 4.6 | Electrical Measurements | 16 |
| 4.6.1 | Electrical Measurements at Room Temperature | 16 |
| 4.6.2 | Electrical Measurements at High and Low Temperatures | 16 |
| 4.6.3 | Circuits for Electrical Measurements | 16 |
| 4.7 | Burn-in Tests | 16 |
| 4.7.1 | Parameter Drift Values | 16 |
| 4.7.2 | Conditions for H.T.R.B. and Power Burn-in | 16 |
| 4.7.3 | Electrical Circuits for H.T.R.B. and Power Burn-in | 16 |
| 4.8 | Environmental and Endurance Tests | 36 |
| 4.8.1 | Electrical Measurements on Completion of Environmental Tests | 36 |
| 4.8.2 | Electrical Measurements at Intermediate Points during Endurance Tests | 36 |
| 4.8.3 | Electrical Measurements on Completion of Endurance Tests | 36 |
| 4.8.4 | Conditions for Operating Life Tests | 36 |
| 4.8.5 | Electrical Circuits for Operating Life Tests | 36 |
| 4.8.6 | Conditions for High Temperature Storage Test | 36 |

| | | | | |
|--|--|--|---|---------------------------|
|  |  | <p style="text-align: center;">ESA/SCC Detail Specification No. 9207/008</p> | <p style="text-align: center;">Rev. 'C'</p> | <p>PAGE 4 ISSUE 1</p> |
|--|--|--|---|---------------------------|

| | |
|------------------------------------|-------------|
| | <u>Page</u> |
| 4.9 Total Dose Irradiation Testing | 36 |
| 4.9.1 Application | 36 |
| 4.9.2 Bias Conditions | 36 |
| 4.9.3 Electrical Measurements | 36 |

TABLES

| | |
|--|----|
| 1(a) Type Variants | 6 |
| 1(b) Maximum Ratings | 6 |
| 2 Electrical Measurements at Room Temperature - d.c. Parameters | 17 |
| Electrical Measurements at Room Temperature - a.c. Parameters | 21 |
| 3 Electrical Measurements at High and Low Temperatures | 23 |
| 4 Parameter Drift Values | 31 |
| 5(a) Conditions for Burn-in High Temperature Reverse Bias, N-Channels | 32 |
| 5(b) Conditions for Burn-in High Temperature Reverse Bias, P-Channels | 32 |
| 5(c) Conditions for Power Burn-in and Operating Life Test | 33 |
| 6 Electrical Measurements on Completion of Environmental Tests and at Intermediate Points and on Completion of Endurance Testing | 37 |
| 7 Electrical Measurements During and on Completion of Irradiation Testing | 39 |

FIGURES

| | |
|---|----|
| 1 Not applicable | |
| 2 Physical Dimensions | 7 |
| 3(a) Pin Assignment | 11 |
| 3(b) Truth Table | 12 |
| 3(c) Circuit Schematic | 13 |
| 3(d) Functional Diagram | 13 |
| 3(e) Input and Output Protection Networks | 13 |
| 4 Circuits for Electrical Measurements | 27 |
| 5(a) Electrical Circuit for Burn-in High Temperature Reverse Bias, N-Channels | 34 |
| 5(b) Electrical Circuit for Burn-in High Temperature Reverse Bias, P-Channels | 34 |
| 5(c) Electrical Circuit for Power Burn-in and Operating Life Test | 35 |
| 6 Bias Conditions for Irradiation Testing | 38 |

APPENDICES (Applicable to specific Manufacturers only)

| | |
|--|----|
| 'A' AGREED DEVIATIONS FOR STMICROELECTRONICS (F) | 40 |
|--|----|

**1. GENERAL****1.1 SCOPE**

This specification details the ratings, physical and electrical characteristics, test and inspection data for a silicon, monolithic, high speed CMOS Dual Positive or Negative-Edge Schmitt Retriggerable Monostable Multivibrator with Clear Reset, having fully buffered outputs, based on Type 54HC4538. It shall be read in conjunction with ESA/SCC Generic Specification No. 9000, the requirements of which are supplemented herein.

1.2 COMPONENT TYPE VARIANTS

Variants of the basic type integrated circuits specified herein, which are also covered by this specification, are given in Table 1(a).

1.3 MAXIMUM RATINGS

The maximum ratings, which shall not be exceeded at any time during use or storage, applicable to the integrated circuits specified herein, are as scheduled in Table 1(b).

Maximum ratings shall only be exceeded during testing to the extent specified in this specification and when stipulated in Test Methods and Procedures of the applicable ESA/SCC Generic Specification.

1.4 PARAMETER DERATING INFORMATION (FIGURE 1)

Not applicable.

1.5 PHYSICAL DIMENSIONS

As per Figure 2.

1.6 PIN ASSIGNMENT

As per Figure 3(a).

1.7 TRUTH TABLE

As per Figure 3(b).

1.8 CIRCUIT SCHEMATIC

As per Figure 3(c).

1.9 FUNCTIONAL DIAGRAM

As per Figure 3(d).

1.10 HANDLING PRECAUTIONS

These devices are susceptible to damage by electrostatic discharge. Therefore, suitable precautions shall be employed for protection during all phases of manufacture, testing, packaging, shipment and any handling.

These components are Categorised as Class 2 with a Minimum Critical Path Failure Voltage of 2500 Volts.

1.11 INPUT AND OUTPUT PROTECTION NETWORKS

Protection networks shall be incorporated into each input and output as shown in Figure 3(e).

**TABLE 1(a) - TYPE VARIANTS**

| VARIANT | CASE | FIGURE | LEAD MATERIAL AND/OR FINISH |
|---------|--------------|--------|-----------------------------|
| 01 | FLAT | 2(a) | G2 or G8 |
| 02 | FLAT | 2(a) | G4 |
| 03 | D.I.L. | 2(b) | G2 or G8 |
| 04 | D.I.L. | 2(b) | G4 |
| 05 | CHIP CARRIER | 2(c) | 2 |
| 10 | D.I.L. | 2(d) | G2 |
| 11 | D.I.L. | 2(d) | G4 |
| 12 | SO CERAMIC | 2(e) | G2 |
| 13 | SO CERAMIC | 2(e) | G4 |

TABLE 1(b) - MAXIMUM RATINGS

| NO. | CHARACTERISTICS | SYMBOL | MAXIMUM RATINGS | UNITS | REMARKS |
|-----|--|------------|---|----------|------------------|
| 1 | Supply Voltage | V_{DD} | -0.5 to +7.0 | V | Note 1 |
| 2 | Input Voltage | V_{IN} | -0.5 to $V_{DD} + 0.5$ | V | Notes 1, 2 |
| 3 | Output Voltage | V_{OUT} | -0.5 to $V_{DD} + 0.5$ | V | Notes 1, 3 |
| 4 | Device Dissipation (Continuous) | P_D | 300 | mW | Note 4 |
| 5 | Supply Current | I_{DDop} | 50 | mA | |
| 6 | Operating Temperature Range | T_{op} | -55 to +125 | °C | T_{amb} |
| 7 | Storage Temperature Range | T_{stg} | -65 to +150 | °C | |
| 8 | Soldering Temperature For FP and DIP For CCP | T_{sol} | +265 +245 | °C | Note 5 Note 6 |
| 9 | External Resistor (Pins 2-14) | R_x | $V_{DD} = 2.0V$: 5.0k to 1.0M $V_{DD} \geq 3.0V$: 1.0k to 1.0M | Ω | |

NOTES

- Device is functional for $2.0V \leq V_{DD} \leq 6.0V$.
- Input current limited to $I_{IC} = \pm 20mA$.
- Output current limited to $I_{OUT} = \pm 25mA$.
- The maximum device dissipation is determined by $I_{DDop} \text{ max. } (50mA) \times 6.0V$.
- Duration 10 seconds maximum at a distance of not less than 1.5mm from the device body and the same lead shall not be resoldered until 3 minutes have elapsed.
- Duration 5 seconds maximum and the same terminal shall not be resoldered until 3 minutes have elapsed.

FIGURE 1 - PARAMETER DERATING INFORMATION

Not applicable.



FIGURE 2 - PHYSICAL DIMENSIONS

FIGURE 2(a) - FLAT PACKAGE, 16-PIN

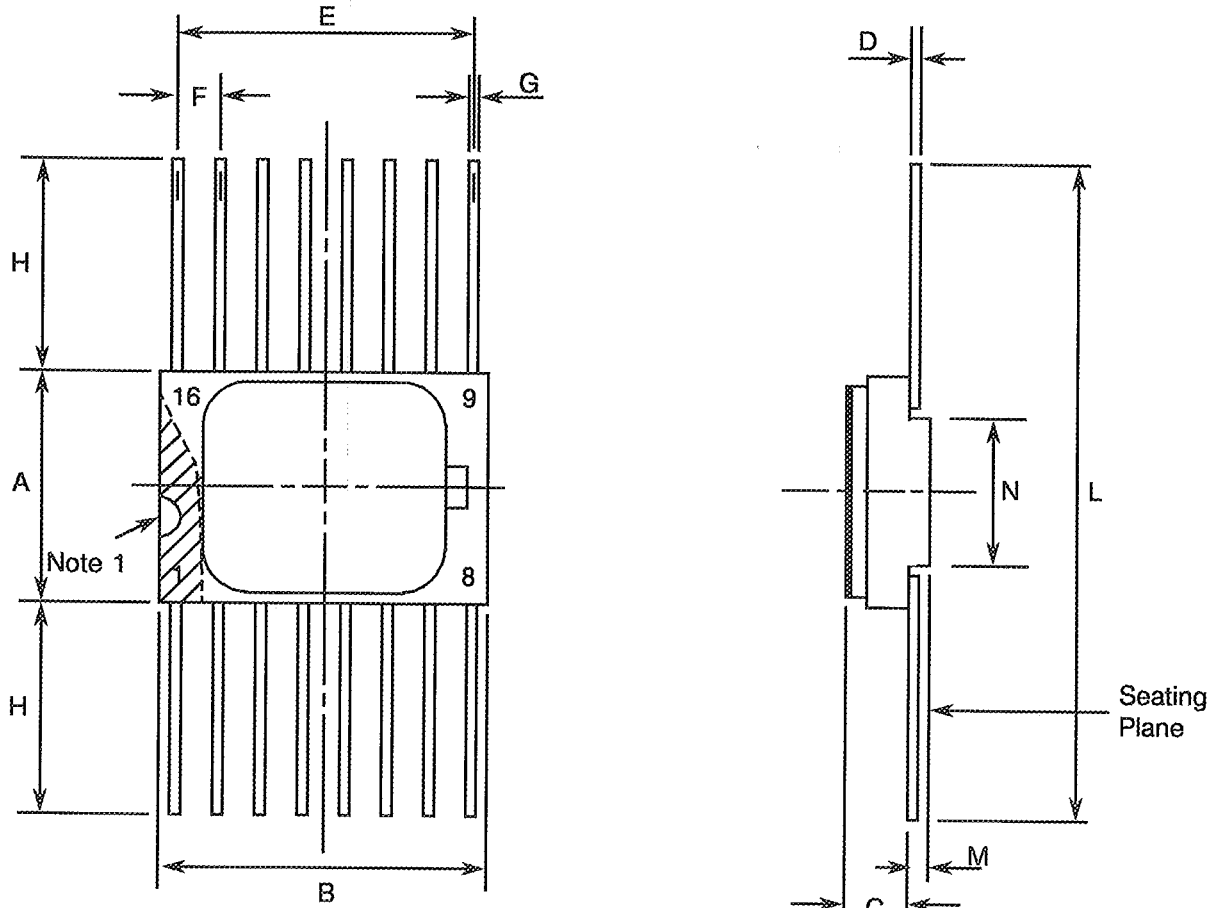

| SYMBOL | MILLIMETRES | | NOTES |
|--------|--------------|-------|-------|
| | MIN | MAX | |
| A | 6.75 | 7.06 | |
| B | 9.76 | 10.14 | |
| C | 1.49 | 1.95 | |
| D | 0.10 | 0.15 | 8 |
| E | 8.76 | 9.01 | |
| F | 1.27 TYPICAL | | 5, 9 |
| G | 0.38 | 0.48 | 8 |
| H | 6.0 | - | 8 |
| L | 18.75 | 22.0 | |
| M | 0.33 | 0.43 | |
| N | 4.31 TYPICAL | | |

NOTES: See Page 10.

FIGURE 2 - PHYSICAL DIMENSIONS (CONTINUED)

FIGURE 2(b) - DUAL-IN-LINE PACKAGE, 16-PIN

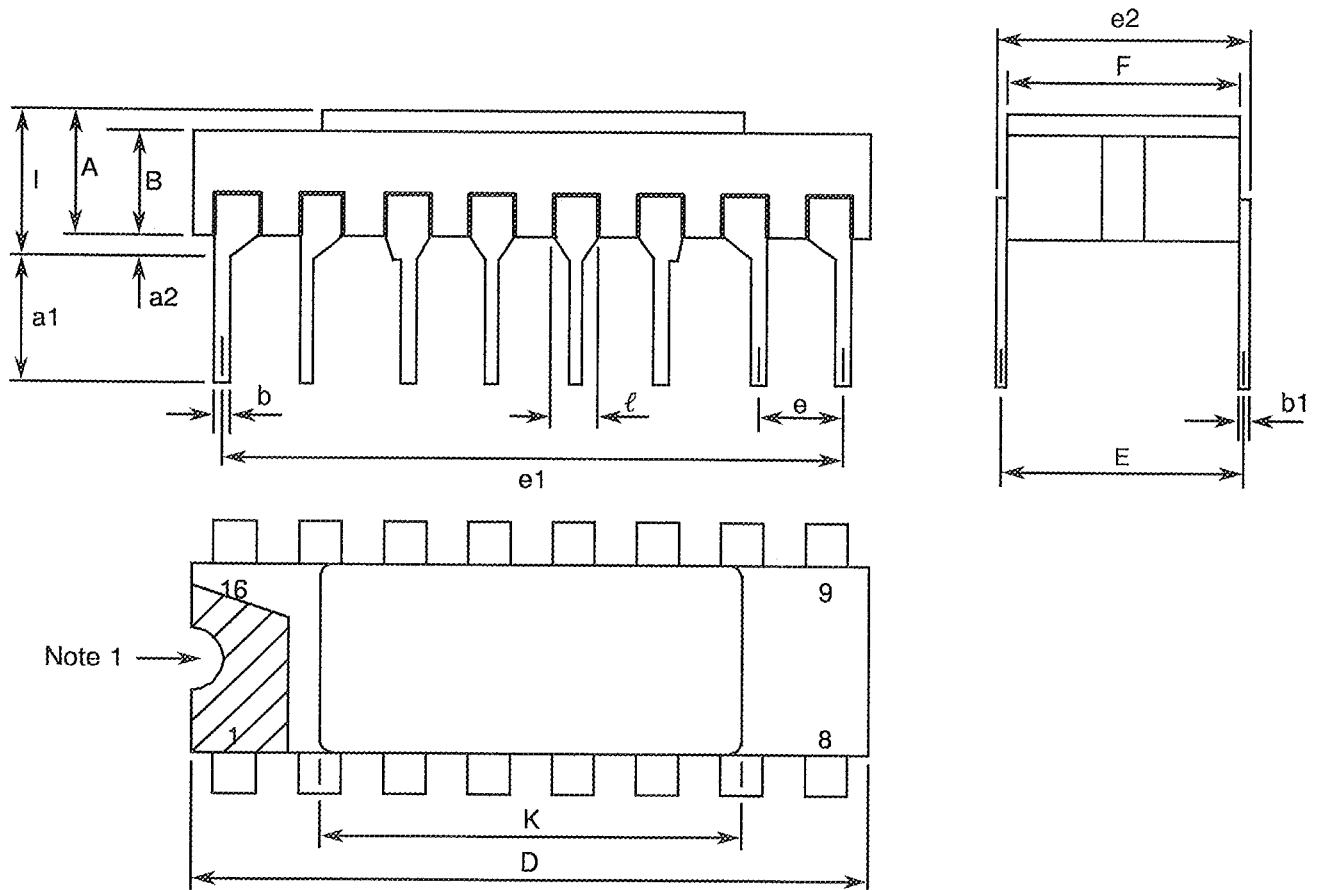

| SYMBOL | MILLIMETRES | | NOTES |
|--------|--------------|-------|-------|
| | MIN | MAX | |
| A | 2.10 | 2.54 | |
| a1 | 3.0 | 3.70 | |
| a2 | 0.63 | 1.14 | 2 |
| B | 1.82 | 2.23 | |
| b | 0.40 | 0.50 | 5 |
| b1 | 0.20 | 0.30 | 5 |
| D | 18.79 | 19.20 | |
| E | 7.36 | 7.87 | |
| e | 2.54 TYPICAL | | 4, 6 |
| e1 | 17.65 | 17.90 | |
| e2 | 7.62 | 8.12 | |
| F | 7.11 | 7.62 | |
| l | - | 3.70 | |
| K | 10.90 | 12.10 | |
| ℓ | 1.27 TYPICAL | | 5 |

NOTES: See Page 10.



FIGURE 2 - PHYSICAL DIMENSIONS (CONTINUED)

FIGURE 2(c) - CHIP CARRIER - 20-TERMINAL

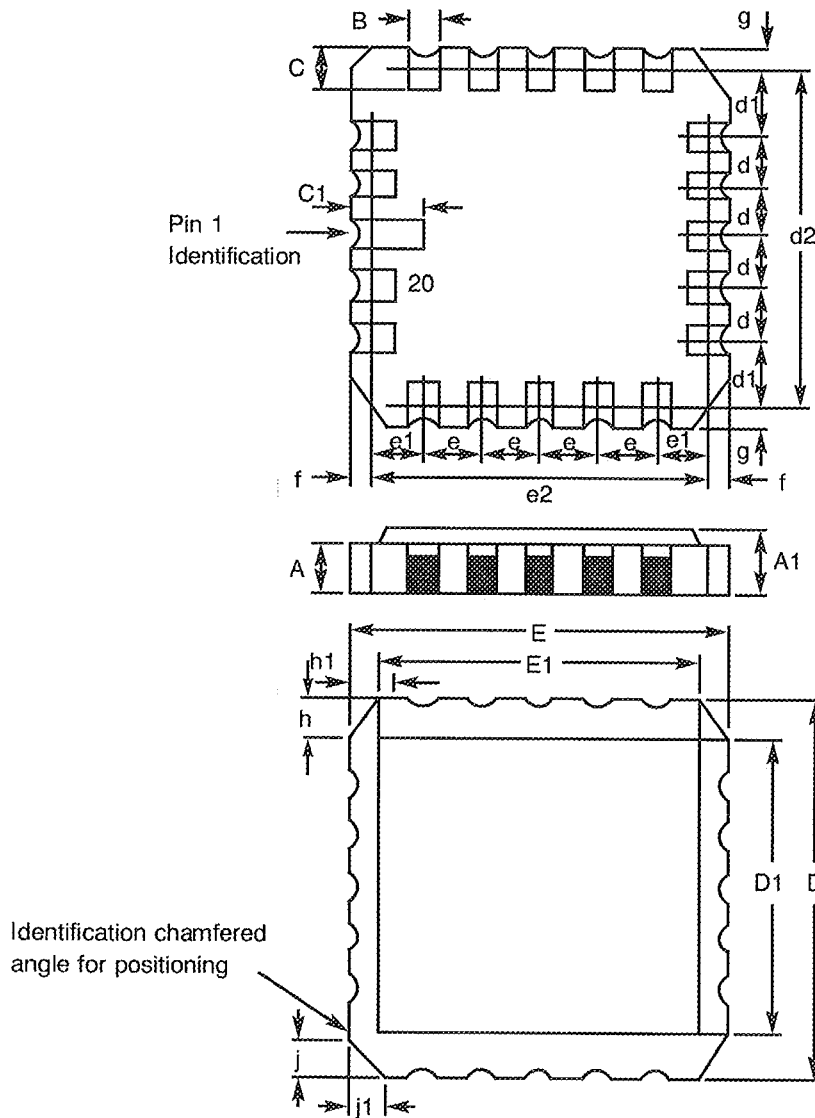

| DIMENSIONS | MILLIMETRES | | NOTES |
|----------------|-------------|---------|-------|
| | MIN | MAX | |
| A | 1.14 | 1.95 | |
| A1 | 1.63 | 2.36 | |
| B | 0.55 | 0.72 | 3 |
| C | 1.06 | 1.47 | 3 |
| C ₁ | 1.91 | 2.41 | |
| D | 8.67 | 9.09 | |
| D1 | 7.21 | 7.52 | |
| d, d1 | 1.27 | TYPICAL | 4 |
| d2 | 7.62 | TYPICAL | |
| E | 8.67 | 9.09 | |
| E1 | 7.21 | 7.52 | |
| e, e1 | 1.27 | TYPICAL | 4 |
| e2 | 7.62 | TYPICAL | |
| f, g | - | 0.76 | |
| h, h1 | 1.01 | TYPICAL | 6 |
| j, j1 | 0.51 | TYPICAL | 5 |

NOTES: See Page 10.

FIGURE 2 - PHYSICAL DIMENSIONS (CONTINUED)

FIGURE 2(d) - DUAL-IN-LINE PACKAGE, 16-PIN

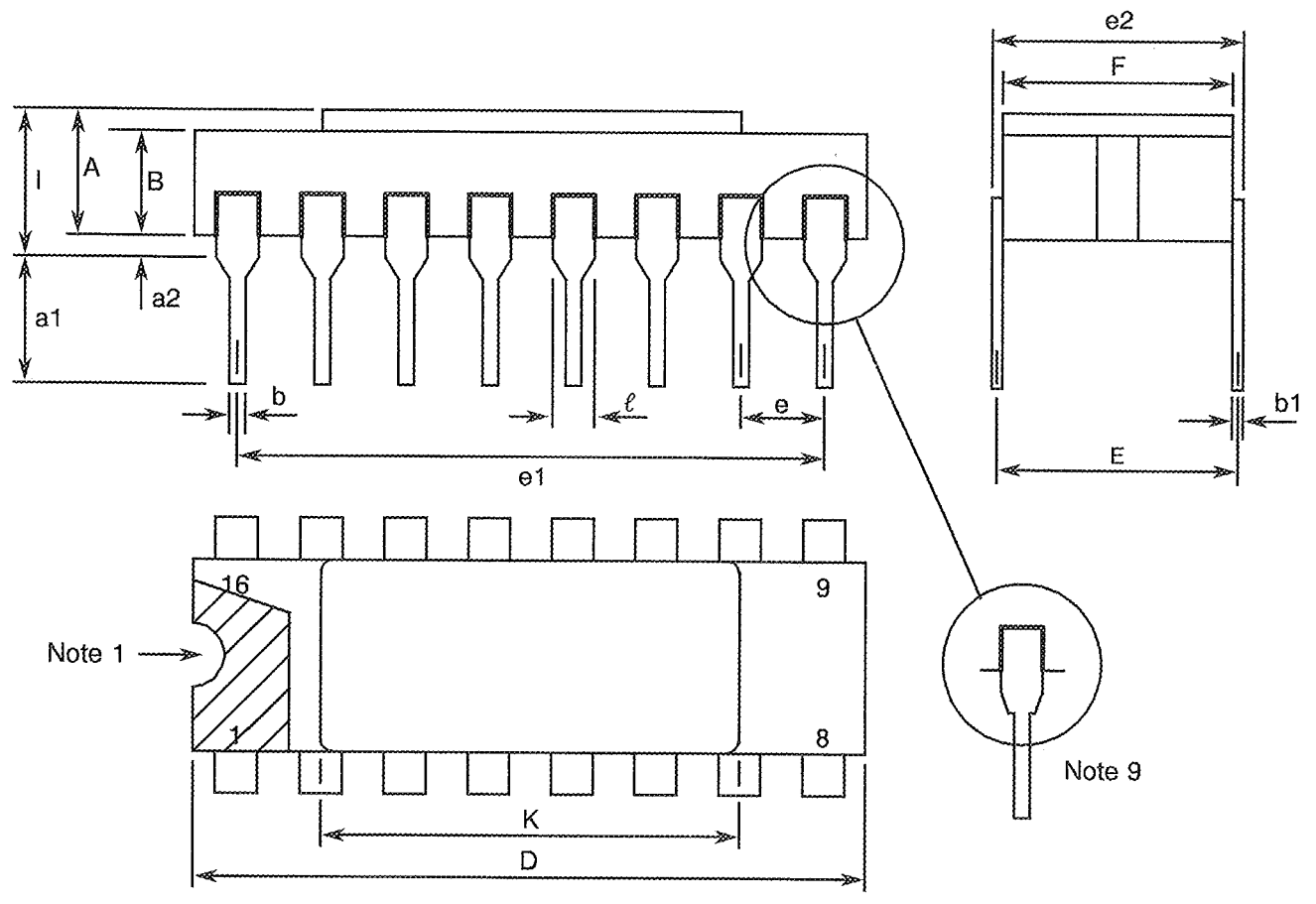

| SYMBOL | MILLIMETRES | | NOTES |
|--------|--------------|-------|-------|
| | MIN | MAX | |
| A | 2.10 | 2.71 | |
| a1 | 3.00 | 3.70 | |
| a2 | 0.63 | 1.14 | 3 |
| B | 1.82 | 2.39 | |
| b | 0.40 | 0.50 | 8 |
| b1 | 0.20 | 0.30 | 8 |
| D | 20.06 | 20.58 | |
| E | 7.36 | 7.87 | |
| e | 2.54 TYPICAL | | 6, 9 |
| e1 | 17.65 | 17.90 | |
| e2 | 7.62 | 8.12 | |
| F | 7.29 | 7.70 | |
| l | - | 3.83 | |
| K | 10.90 | 12.10 | |
| l | 1.14 | 1.50 | 8 |

NOTES: See Page 10.

**SCC**

ESA/SCC Detail Specification

No. 9207/008

Rev. 'C'

PAGE 10

ISSUE 1

FIGURE 2 - PHYSICAL DIMENSIONS (CONTINUED)**NOTES TO FIGURES 2(a) TO 2(e) INCLUSIVE**

1. Index area: a notch, letter or dot shall be located adjacent to Pin 1 and shall be within the shaded area shown. For chip carrier packages the index shall be as defined in Figure 2(c).
2. The dimension shall be measured from the seating plane to the base plane.
3. The true position pin or terminal spacing is 1.27mm between centrelines. Each pin or terminal centreline shall be located within $\pm 0.13\text{mm}$ of it's true longitudinal position relative to Pin 1 and the highest pin number.
4. The true position pin spacing is 2.54mm between centrelines. Each pin centreline shall be located within $\pm 0.25\text{mm}$ of it's true longitudinal position relative to Pin 1 and the highest pin number.
5. All leads or terminals.
6. 14 spaces for flat and dual-in-line packages.
16 spaces for chip carrier packages.
7. Index corner only - 2 dimensions.
8. 3 non-index corners - 6 dimensions.
9. For all pins, either pin shape may be supplied.



FIGURE 2 - PHYSICAL DIMENSIONS (CONTINUED)

FIGURE 2(e) - SMALL OUTLINE CERAMIC PACKAGE, 16-PIN

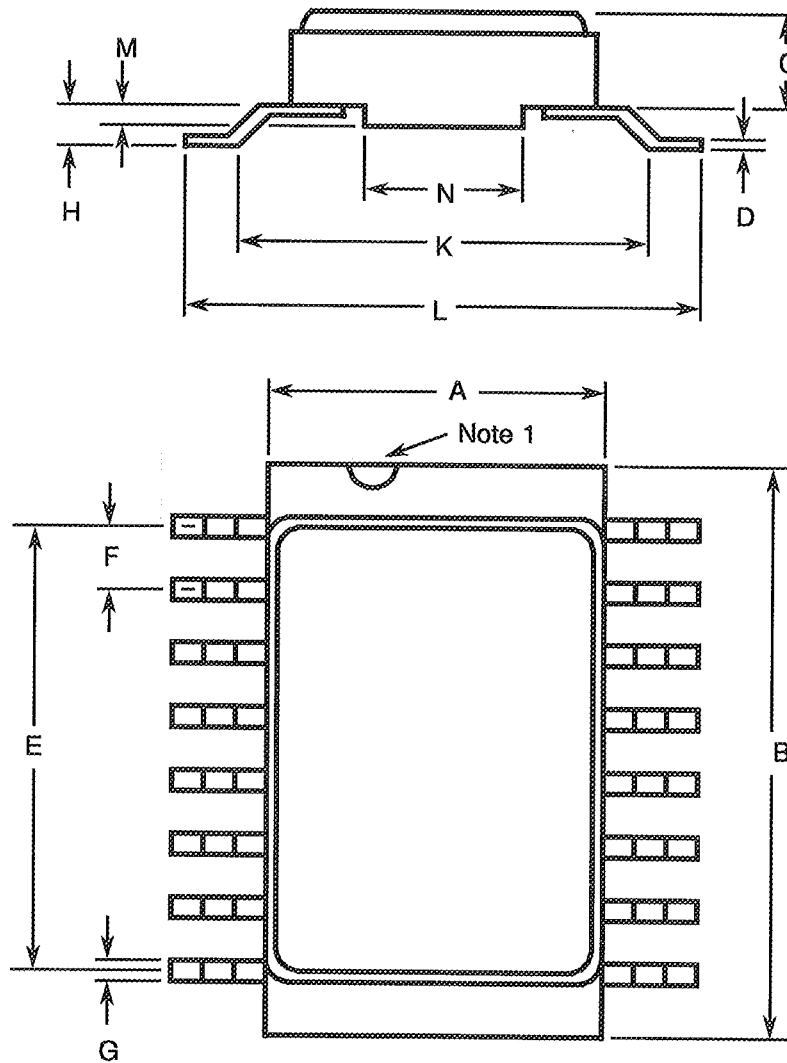

| SYMBOL | MILLIMETRES | | NOTES |
|--------|--------------|-------|-------|
| | MIN. | MAX. | |
| A | 6.75 | 7.06 | |
| B | 9.76 | 10.14 | |
| C | 1.49 | 1.95 | |
| D | 0.102 | 0.152 | 8 |
| E | 8.76 | 9.01 | |
| F | 1.27 TYPICAL | | 5, 9 |
| G | 0.38 | 0.48 | 8 |
| H | 0.60 | 0.90 | 8 |
| K | 9.00 TYPICAL | | |
| L | 10 | 10.65 | |
| M | 0.33 | 0.43 | |
| N | 4.31 TYPICAL | | |

NOTES: See Page 10.



FIGURE 3(a) - PIN ASSIGNMENT

DUAL-IN-LINE, SO AND FLAT PACKAGE

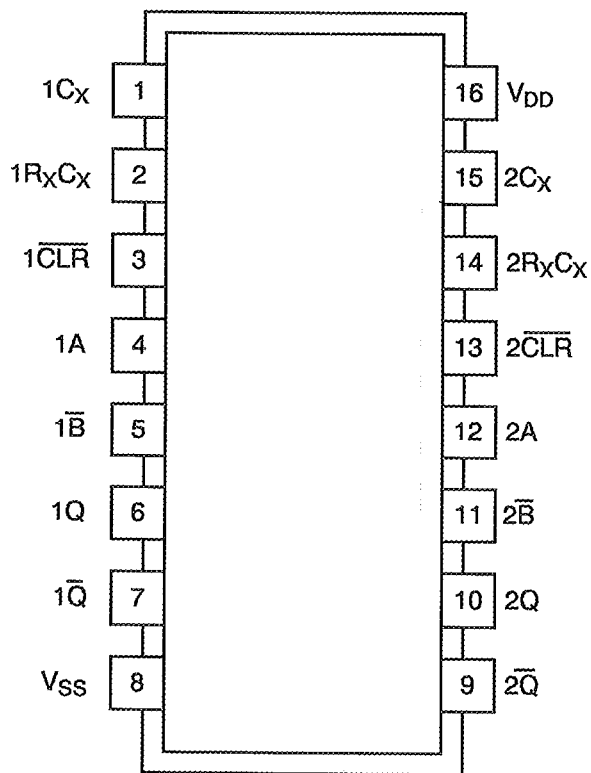

(TOP VIEW)

CHIP CARRIER PACKAGE

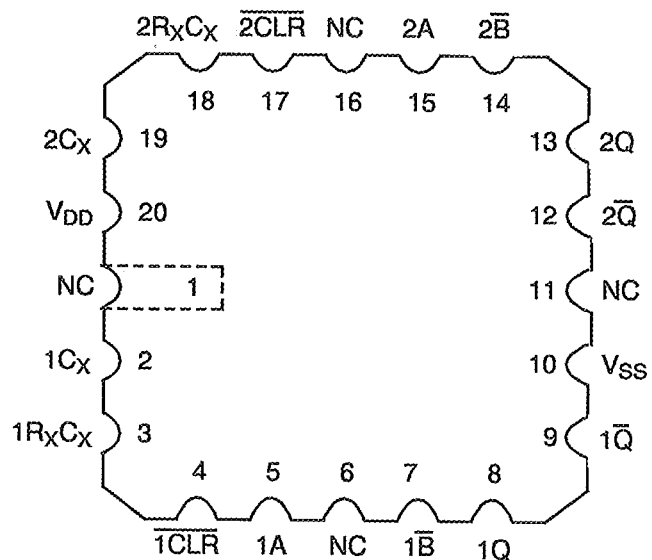

(TOP VIEW)

FLAT PACKAGE, SO AND DUAL-IN-LINE TO CHIP CARRIER PIN ASSIGNMENT

| | | | | | | | | | | | | | | | | |
|---|---|---|---|---|---|---|---|----|----|----|----|----|----|----|----|----|
| FLAT PACKAGE, SO AND DUAL-IN-LINE PIN OUTS | 1 | 2 | 3 | 4 | 5 | 6 | 7 | 8 | 9 | 10 | 11 | 12 | 13 | 14 | 15 | 16 |
| CHIP CARRIER PIN OUTS | 2 | 3 | 4 | 5 | 7 | 8 | 9 | 10 | 12 | 13 | 14 | 15 | 17 | 18 | 19 | 20 |



FIGURE 3(b) - TRUTH TABLE (EACH MULTIVIBRATOR)

| INPUTS | | | OUTPUTS | |
|------------|----------------|------------------|--------------|----------------|
| A | \overline{B} | \overline{CLR} | Q | \overline{Q} |
| X | X | L | L | H |
| H | X | X | L | H |
| X | L | X | L | H |
| L | \downarrow | H | \uparrow | \downarrow |
| \uparrow | H | H | \downarrow | \uparrow |

NOTES

- 1. Logic Level Definitions: L = Low Level, H = High Level, X = Irrelevant.
- 2. \uparrow = Transition, Low to High, \downarrow = Transition High to Low.
- 3. \uparrow = High level pulse for time period determined by R_X, C_X .
- 4. \downarrow = Low level pulse for time period determined by R_X, C_X .

TIMING CHART

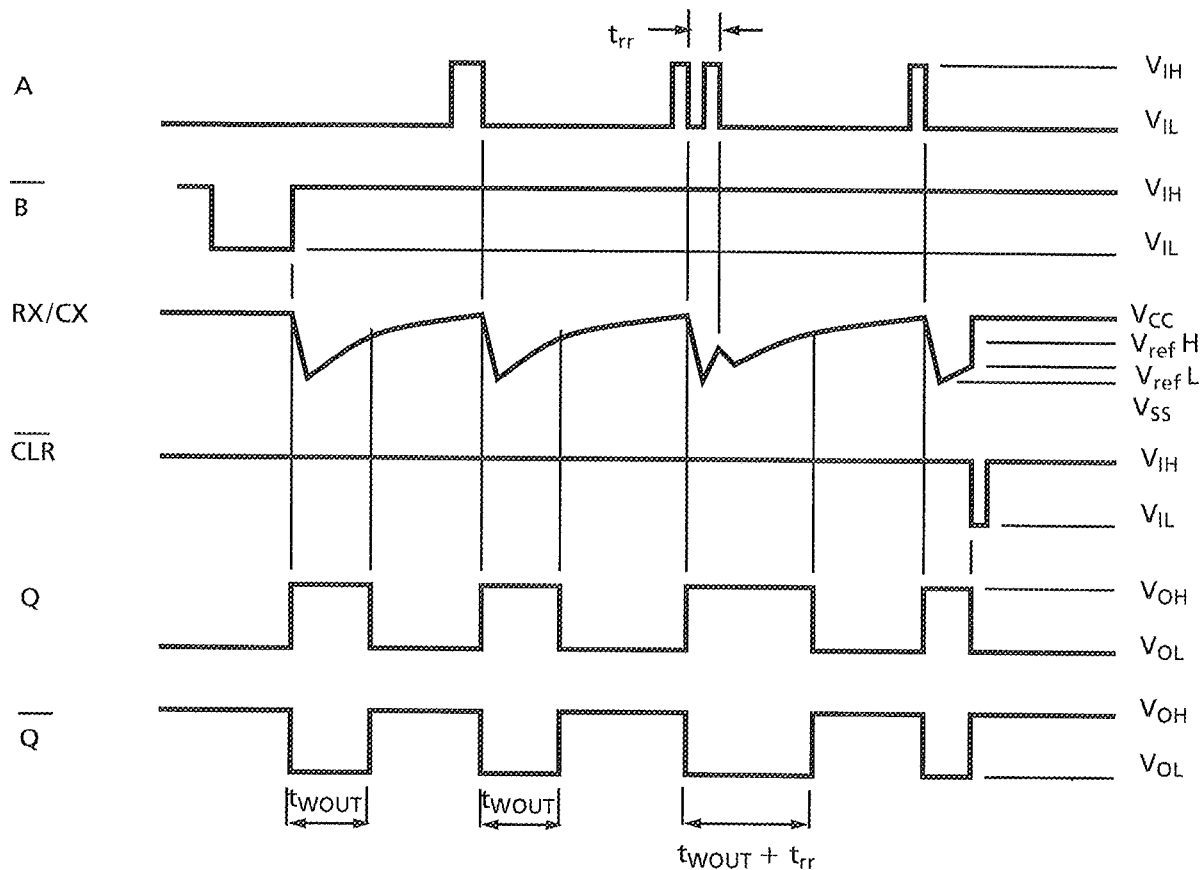
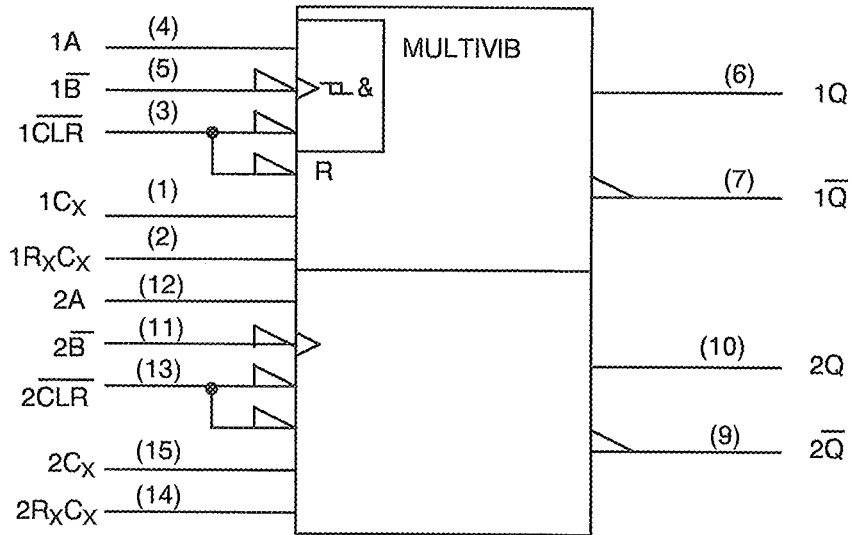

FIGURE 3(c) - CIRCUIT SCHEMATIC

Not applicable.

FIGURE 3(d) - FUNCTIONAL DIAGRAM





NOTES

1. Pin numbers shown are for DIP and FP.

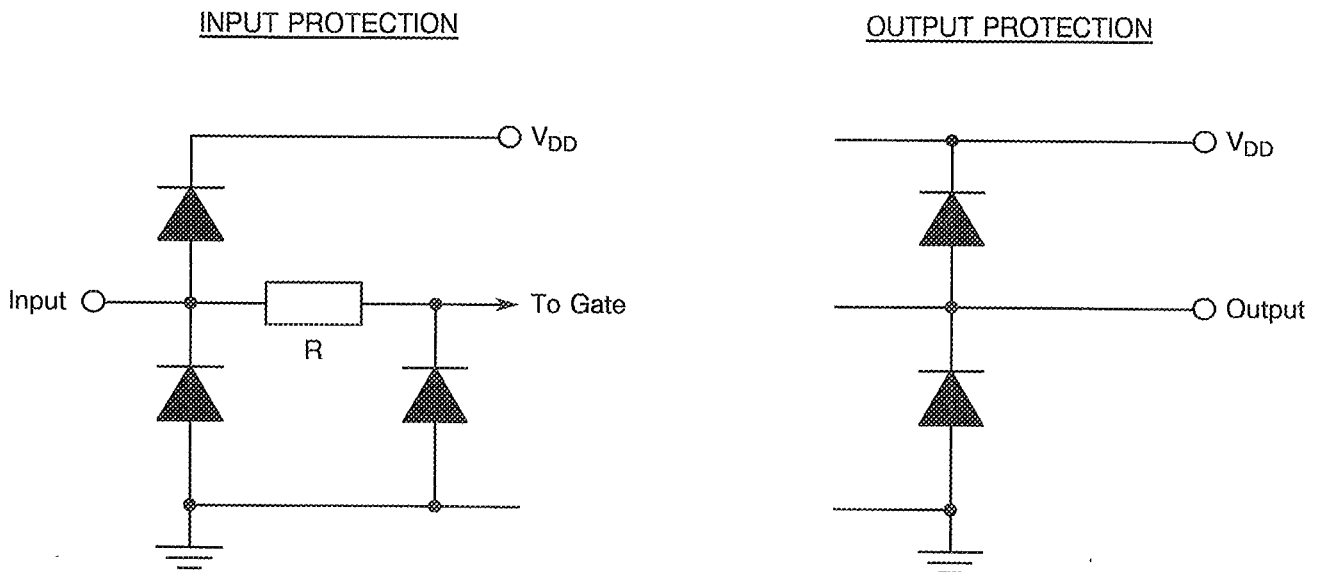
FIGURE 3(e) - INPUT AND OUTPUT PROTECTION NETWORKS



| | | |
|--|--|--------------------|
|   | ESA/SCC Detail Specification No. 9207/008 | PAGE 14 ISSUE 1 |
|--|--|--------------------|

2. APPLICABLE DOCUMENTS

The following documents form part of this specification and shall be read in conjunction with it:-

- (a) ESA/SCC Generic Specification No. 9000 for Integrated Circuits.
- (b) MIL-STD-883, Test Methods and Procedures for Micro-electronics.

3. TERMS, DEFINITIONS, ABBREVIATIONS, SYMBOLS AND UNITS

For the purpose of this specification, the terms, definitions, abbreviations, symbols and units specified in ESA/SCC Basic Specification No. 21300 shall apply. In addition, the following symbols are used:

- V_{IC} = Input Clamp Voltage.
- I_{IC} = Input Clamp Diode Current.

4. REQUIREMENTS

4.1 GENERAL

The complete requirements for procurement of the integrated circuits specified herein are stated in this specification and ESA/SCC Generic Specification No. 9000 for Integrated Circuits. Deviations from the Generic Specification, applicable to this specification only, are listed in Para. 4.2.

Deviations from the applicable Generic Specification and this Detail Specification, formally agreed with specific Manufacturers on the basis that the alternative requirements are equivalent to the ESA/SCC requirements and do not affect the components' reliability, are listed in the appendices attached to this specification.

4.2 DEVIATIONS FROM GENERIC SPECIFICATION

4.2.1 Deviations from Special In-process Controls

- (a) Para. 5.2.2, Total Dose Irradiation Testing: Shall be performed during irradiation qualification and maintenance of qualification.
- (b) Para. 5.2.2, Total Dose Irradiation Testing: Shall be performed during procurement on an irradiation lot acceptance basis at the total dose irradiation level specified in the Purchase Order.

4.2.2 Deviations from Final Production Tests (Chart II)

None.

4.2.3 Deviations from Burn-in Tests (Chart III)

None.

4.2.4 Deviations from Qualification Tests (Chart IV)

None.



4.2.5 Deviations from Lot Acceptance Tests (Chart V)

None.

4.3 MECHANICAL REQUIREMENTS

4.3.1 Dimension Check

The dimensions of the integrated circuits specified herein shall be checked. They shall conform to those shown in Figure 2.

4.3.2 Weight

The maximum weight of the integrated circuits specified herein shall be 2.2 grammes for the dual-in-line package, 0.7 grammes for the flat and SO packages and 0.6 grammes for the chip carrier package.

4.4 MATERIALS AND FINISHES

The materials shall be as specified herein. Where a definite material is not specified, a material which will enable the integrated circuits specified herein to meet the performance requirements of this specification shall be used. Acceptance or approval of any constituent material does not guarantee acceptance of the finished product.

4.4.1 Case

The case shall be hermetically sealed and have a metal body with hard glass seals or a ceramic body and the lids shall be welded, brazed, preform-soldered or glass frit sealed.

4.4.2 Lead Material and Finish

For dual-in-line and flat packages, the material shall be Type 'G' with either Type '2', Type '4' or Type '2 or 8' finish in accordance with the requirements of ESA/SCC Basic Specification No. 23500. For chip carrier packages the finish shall be Type '2' in accordance with the requirements of ESA/SCC Basic Specification No. 23500. For SO ceramic packages, the material shall be Type 'G' with either Type '2' or Type '4' finish in accordance with the requirements of ESA/SCC Basic Specification No. 23500. (See Table 1(a) for Type Variants).

4.5 MARKING

4.5.1 General

The marking of all components delivered to this specification shall be in accordance with the requirements of ESA/SCC Basic Specification No. 21700. Each component shall be marked in respect of:-

- (a) Lead Identification.
- (b) The SCC Component Number.
- (c) Traceability Information.

4.5.2 Lead Identification

For dual-in-line, flat and SO packages, an index shall be located at the top of the package in the position defined in Note 1 to Figure 2 or, alternatively, a tab may be used to identify Pin No. 1. The pin numbering must be read with the index or tab on the left-hand side. For chip carrier packages, the index shall be as defined by Figure 2(c).

4.5.3 The SCC Component Number

Each component shall bear the SCC Component Number which shall be constituted and marked as follows:

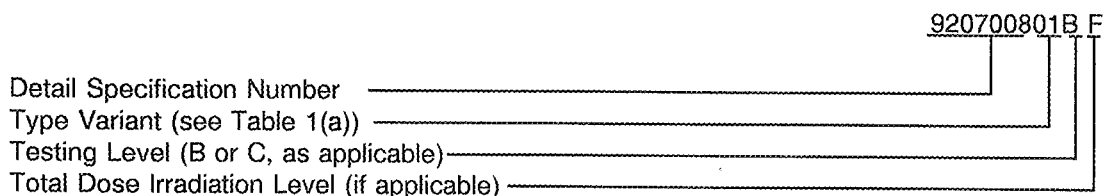

The Total Dose Irradiation Level designation shall be added for those devices for which a sample has been successfully tested to the level in question. For these devices, a code letter shall be added in accordance with the requirements of ESA/SCC Basic Specification No. 22900.

4.5.4 Traceability Information

Each component shall be marked in respect of traceability information in accordance with the requirements of ESA/SCC Basic Specification No. 21700.

4.6 ELECTRICAL MEASUREMENTS

4.6.1 Electrical Measurements at Room Temperature

The parameters to be measured in respect of electrical characteristics are scheduled in Table 2. Unless otherwise specified, the measurements shall be performed at $T_{amb} = +22 \pm 3 \text{ }^\circ\text{C}$.

4.6.2 Electrical Measurements at High and Low Temperatures

The parameters to be measured at high and low temperatures are scheduled in Table 3. The measurements shall be performed at $T_{amb} = +125 (+0 -5) \text{ }^\circ\text{C}$ and $-55 (+5 -0) \text{ }^\circ\text{C}$ respectively.

4.6.3 Circuits for Electrical Measurements

Circuits and test sequences for use in performing electrical measurements listed in Tables 2 and 3 of this specification are shown in Figure 4.

4.7 BURN-IN TESTS

4.7.1 Parameter Drift Values

The parameter drift values applicable to H.T.R.B. and Power Burn-in are specified in Table 4 of this specification. Unless otherwise stated, measurements shall be performed at $T_{amb} = +22 \pm 3 \text{ }^\circ\text{C}$. The parameter drift values (Δ) applicable to the parameters scheduled, shall not be exceeded. In addition to these drift value requirements, the appropriate limit value specified for a given parameter in Table 2 shall not be exceeded.

For H.T.R.B. Burn-in, the parameter drift values (Δ) shall be applied before the N-Channel (0 hours) and after the P-Channel (144 hours) burn-in.

4.7.2 Conditions for H.T.R.B. and Power Burn-in

The requirements for H.T.R.B. and Power Burn-in are specified in Section 7 of ESA/SCC Generic Specification No. 9000. The conditions for H.T.R.B. and Power Burn-in shall be as specified in Tables 5(a), 5(b) and 5(c) of this specification.

4.7.3 Electrical Circuits for H.T.R.B and Power Burn-in

Circuits for use in performing the H.T.R.B. and Power Burn-in tests are shown in Figures 5(a), 5(b) and 5(c) of this specification.



TABLE 2 - ELECTRICAL MEASUREMENTS AT ROOM TEMPERATURE - d.c. PARAMETERS

| NO. | CHARACTERISTICS | SYMBOL | TEST METHOD MIL-STD 883 | TEST FIG. | TEST CONDITIONS (PINS UNDER TEST D/F = DIP AND FP C = CCP) | LIMITS | | UNIT |
|----------|-------------------------|--------------|-------------------------|-----------|--|--------|-----|---------|
| | | | | | | MIN | MAX | |
| 1 | Functional Test 1 | - | - | 3(b) | Verify Truth Table without Load. $V_{IL} = 0.3V, V_{IH} = 1.5V$ $V_{DD} = 2.0V, V_{SS} = 0V$ $t_r = t_f < 1.0\mu s$ (CLR only) $f = 10kHz$ (min) Note 1 | - | - | - |
| 2 | Functional Test 2 | - | - | 3(b) | Verify Truth Table without Load. $V_{IL} = 0.9V, V_{IH} = 3.15V$ $V_{DD} = 4.5V, V_{SS} = 0V$ $t_r = t_f < 500ns$ (CLR only) $f = 10kHz$ (min) Note 1 | - | - | - |
| 3 | Functional Test 3 | - | - | 3(b) | Verify Truth Table without Load. $V_{IL} = 1.2V, V_{IH} = 4.2V$ $V_{DD} = 6.0V, V_{SS} = 0V$ $t_r = t_f < 400ns$ (CLR only) $f = 10kHz$ (min) Note 1 | - | - | - |
| 4 to 5 | Quiescent Current | I_{DD} | 3005 | 4(a) | $V_{IL} = 0V, V_{IH} = 6.0V$ $V_{DD} = 6.0V, V_{SS} = 0V$ All Outputs Open Note 2 (Pin D/F 16) (Pin C 20) | - | 0.4 | μA |
| 6 to 7 | Active Supply Current 1 | $I_{DD}(S1)$ | 3005 | 4(a) | $V_{IL} = 0V, V_{IH} = 2.0V$ $V_H = 1.0V$ $V_{DD} = 2.0V, V_{SS} = 0V$ All Outputs Open Note 2 (Pin D/F 16) (Pin C 20) | - | 200 | μA |
| 8 to 9 | Active Supply Current 2 | $I_{DD}(S2)$ | 3005 | 4(a) | $V_{IL} = 0V, V_{IH} = 4.5V$ $V_H = 2.25V$ $V_{DD} = 4.5V, V_{SS} = 0V$ All Outputs Open Note 2 (Pin D/F 16) (Pin C 20) | - | 600 | μA |
| 10 to 11 | Active Supply Current 3 | $I_{DD}(S3)$ | 3005 | 4(a) | $V_{IL} = 0V, V_{IH} = 6.0V$ $V_H = 3.0V$ $V_{DD} = 6.0V, V_{SS} = 0V$ All Outputs Open Note 2 (Pin D/F 16) (Pin C 20) | - | 1.0 | mA |

NOTES: See Page 20.

**TABLE 2 - ELECTRICAL MEASUREMENTS AT ROOM TEMPERATURE - d.c. PARAMETERS (CONT'D)**

| NO. | CHARACTERISTICS | SYMBOL | TEST METHOD MIL-STD 883 | TEST FIG. | TEST CONDITIONS (PINS UNDER TEST D/F = DIP AND FP C = CCP) | LIMITS | | UNIT |
|----------------|-------------------------------|-----------|-------------------------------|-----------|---|--------|------|------|
| | | | | | | MIN | MAX | |
| 12 to 17 | Input Current Low Level 1 | I_{IL1} | 3009 | 4(b) | V_{IN} (Under Test) = 0V V_{IN} (Remaining Inputs) = 6.0V V_{DD} = 6.0V, V_{SS} = 0V (Pins D/F 3-4-5-11-12-13) (Pins C 4-5-7-14-15-17) | - | -50 | nA |
| 18 to 19 | Input Current Low Level 2 | I_{IL2} | 3009 | 4(b) | V_{IN} (Under Test) = 0V V_{IN} (Remaining Inputs) = 6.0V V_{DD} = 6.0V, V_{SS} = 0V (Pins D/F 2-14) (Pins C 3-18) | - | -500 | nA |
| 20 to 25 | Input Current High Level 1 | I_{IH1} | 3010 | 4(c) | V_{IN} (Under Test) = 6.0V V_{IN} (Remaining Inputs) = 0V V_{DD} = 6.0V, V_{SS} = 0V (Pins D/F 3-4-5-11-12-13) (Pins C 4-5-7-14-15-17) | - | 50 | nA |
| 26 to 27 | Input Current High Level 2 | I_{IH2} | 3010 | 4(c) | V_{IN} (Under Test) = 6.0V V_{IN} (Remaining Inputs) = 0V V_{DD} = 6.0V, V_{SS} = 0V (Pins D/F 2-14) (Pins C 3-18) | - | 500 | nA |
| 28 to 31 | Output Voltage Low Level 1 | V_{OL1} | 3007 | 4(d) | V_{IL} = 0.3V, V_{IH} = 1.5V I_{OL} = 20 μ A V_{DD} = 2.0V, V_{SS} = 0V (Pins D/F 6-7-9-10) (Pins C 8-9-12-13) | - | 0.1 | V |
| 32 to 35 | Output Voltage Low Level 2 | V_{OL2} | 3007 | 4(d) | V_{IL} = 0.9V, V_{IH} = 3.15V I_{OL} = 20 μ A V_{DD} = 4.5V, V_{SS} = 0V (Pins D/F 6-7-9-10) (Pins C 8-9-12-13) | - | 0.1 | V |
| 36 to 39 | Output Voltage Low Level 3 | V_{OL3} | 3007 | 4(d) | V_{IL} = 1.2V, V_{IH} = 4.2V I_{OL} = 20 μ A V_{DD} = 6.0V, V_{SS} = 0V (Pins D/F 6-7-9-10) (Pins C 8-9-12-13) | - | 0.1 | V |

NOTES: See Page 20.



TABLE 2 - ELECTRICAL MEASUREMENTS AT ROOM TEMPERATURE - d.c. PARAMETERS (CONT'D)

| NO. | CHARACTERISTICS | SYMBOL | TEST METHOD MIL-STD 883 | TEST FIG. | TEST CONDITIONS (PINS UNDER TEST D/F = DIP AND FP C = CCP) | LIMITS | | UNIT |
|----------------|--------------------------------|------------------|-------------------------------|-----------|--|--------|------|------|
| | | | | | | MIN | MAX | |
| 40 to 43 | Output Voltage Low Level 4 | V _{OL4} | 3007 | 4(d) | V _{IL} = 0.9V, V _{IH} = 3.15V I _{OL} = 4.0mA V _{DD} = 4.5V, V _{SS} = 0V (Pins D/F 6-7-9-10) (Pins C 8-9-12-13) | - | 0.26 | V |
| 44 to 47 | Output Voltage Low Level 5 | V _{OL5} | 3007 | 4(d) | V _{IL} = 1.2V, V _{IH} = 4.2V I _{OL} = 5.2mA V _{DD} = 6.0V, V _{SS} = 0V (Pins D/F 6-7-9-10) (Pins C 8-9-12-13) | - | 0.26 | V |
| 48 to 51 | Output Voltage High Level 1 | V _{OH1} | 3006 | 4(e) | V _{IL} = 0.3V, V _{IH} = 1.5V I _{OH} = -20μA V _{DD} = 2.0V, V _{SS} = 0V (Pins D/F 6-7-9-10) (Pins C 8-9-12-13) | 1.9 | - | V |
| 52 to 55 | Output Voltage High Level 2 | V _{OH2} | 3006 | 4(e) | V _{IL} = 0.9V, V _{IH} = 3.15V I _{OH} = -20μA V _{DD} = 4.5V, V _{SS} = 0V (Pins D/F 6-7-9-10) (Pins C 8-9-12-13) | 4.4 | - | V |
| 56 to 59 | Output Voltage High Level 3 | V _{OH3} | 3006 | 4(e) | V _{IL} = 1.2V, V _{IH} = 4.2V I _{OH} = -20μA V _{DD} = 6.0V, V _{SS} = 0V (Pins D/F 6-7-9-10) (Pins C 8-9-12-13) | 5.9 | - | V |
| 60 to 63 | Output Voltage High Level 4 | V _{OH4} | 3006 | 4(e) | V _{IL} = 0.9V, V _{IH} = 3.15V I _{OH} = -4.0mA V _{DD} = 4.5V, V _{SS} = 0V (Pins D/F 6-7-9-10) (Pins C 8-9-12-13) | 3.98 | - | V |
| 64 to 67 | Output Voltage High Level 5 | V _{OH5} | 3006 | 4(e) | V _{IL} = 1.2V, V _{IH} = 4.2V I _{OH} = -5.2mA V _{DD} = 6.0V, V _{SS} = 0V (Pins D/F 6-7-9-10) (Pins C 8-9-12-13) | 5.48 | - | V |

NOTES: See Page 20.

TABLE 2 - ELECTRICAL MEASUREMENTS AT ROOM TEMPERATURE (CONT'D)

| NO. | CHARACTERISTICS | SYMBOL | TEST METHOD MIL-STD 883 | TEST FIG. | TEST CONDITIONS (PINS UNDER TEST D/F = DIP AND FP C = CCP) | LIMITS | | UNIT |
|----------------|---------------------------------------|-----------|-------------------------------|-----------|---|--------|-------|------|
| | | | | | | MIN | MAX | |
| 68 | Threshold Voltage N-Channel | V_{THN} | - | 4(f) | \overline{CLR} Input at Ground All Other Inputs: $V_{IN} = 5.0V$ $V_{DD} = 5.0V, I_{SS} = -10\mu A$ (Pin D/F 8) (Pin C 10) | -0.45 | -1.45 | V |
| 69 | Threshold Voltage P-Channel | V_{THP} | - | 4(g) | \overline{CLR} Input at Ground All Other Inputs: $V_{IN} = -5.0Vdc$ $V_{SS} = -5.0V, I_{DD} = 10\mu A$ (Pin D/F 16) (Pin C 20) | 0.45 | 1.35 | V |
| 70 to 75 | Input Clamp Voltage (to V_{SS}) | V_{IC1} | - | 4(h) | I_{IN} (Under Test) = $-0.1mA$ $V_{DD} = \text{Open}, V_{SS} = 0V$ All Other Pins Open (Pins D/F 3-4-5-11-12-13) (Pins C 4-5-7-14-15-17) | -0.4 | -0.9 | V |
| 76 to 81 | Input Clamp Voltage (to V_{DD}) | V_{IC2} | - | 4(h) | I_{IN} (Under Test) = $0.1mA$ $V_{DD} = 0V, V_{SS} = \text{Open}$, All Other Pins Open (Pins D/F 3-4-5-11-12-13) (Pins C 4-5-7-14-15-17) | 0.4 | 0.9 | V |

NOTES

1. Maximum time to output comparator strobe $30\mu s$.
2. Test each appropriate pattern of Figure 4(a).
3. Guaranteed but not tested.
4. Measurements shall be performed on a 100% basis go-no-go, with read and record on a sample basis, LTPD7 (32 pieces) after Chart III (Burn-in) Tests.

TABLE 2 - ELECTRICAL MEASUREMENTS AT ROOM TEMPERATURE - a.c. PARAMETERS

| NO. | CHARACTERISTICS | SYMBOL | TEST METHOD MIL-STD 883 | TEST FIG. | TEST CONDITIONS (PINS UNDER TEST D/F = DIP AND FP C = CCP) | LIMITS | | UNIT | | | | | | |
|-----------------|--|------------|-------------------------------|-----------|---|-----------------|---------------|--------|--------|----------|----------|---|----|----|
| | | | | | | MIN | MAX | | | | | | | |
| 82 to 87 | Input Capacitance | C_{IN} | 3012 | 4(i) | V_{IN} (Not Under Test) = 0Vdc $V_{DD} = V_{SS} = 0V$ Note 3 (Pins D/F 3-4-5-11-12-13) (Pins C 4-5-7-14-15-17) | - | 10 | pF | | | | | | |
| 88 to 89 | Propagation Delay High to Low, (A to Q) | t_{PHL1} | 3003 | 4(j) | V_{IN} (Under Test) = Pulse Generator V_{IN} (Remaining Inputs) = Figure 3(b). $V_{DD} = 4.5V, V_{SS} = 0V$ Note 4 <table style="margin-left: auto; margin-right: auto; border-collapse: collapse;"> <tr> <td style="border-bottom: 1px solid black; padding: 0 5px;"><u>Pins D/F</u></td> <td style="border-bottom: 1px solid black; padding: 0 5px;"><u>Pins C</u></td> </tr> <tr> <td style="padding: 0 5px;">4 to 7</td> <td style="padding: 0 5px;">5 to 9</td> </tr> <tr> <td style="padding: 0 5px;">12 to 9</td> <td style="padding: 0 5px;">15 to 12</td> </tr> </table> | <u>Pins D/F</u> | <u>Pins C</u> | 4 to 7 | 5 to 9 | 12 to 9 | 15 to 12 | - | 50 | ns |
| <u>Pins D/F</u> | <u>Pins C</u> | | | | | | | | | | | | | |
| 4 to 7 | 5 to 9 | | | | | | | | | | | | | |
| 12 to 9 | 15 to 12 | | | | | | | | | | | | | |
| 90 to 91 | Propagation Delay Low to High, (A to Q) | t_{PLH1} | 3003 | 4(j) | V_{IN} (Under Test) = Pulse Generator V_{IN} (Remaining Inputs) = Figure 3(b) $V_{DD} = 4.5V, V_{SS} = 0V$ Note 4 <table style="margin-left: auto; margin-right: auto; border-collapse: collapse;"> <tr> <td style="border-bottom: 1px solid black; padding: 0 5px;"><u>Pins D/F</u></td> <td style="border-bottom: 1px solid black; padding: 0 5px;"><u>Pins C</u></td> </tr> <tr> <td style="padding: 0 5px;">4 to 6</td> <td style="padding: 0 5px;">5 to 8</td> </tr> <tr> <td style="padding: 0 5px;">12 to 10</td> <td style="padding: 0 5px;">15 to 13</td> </tr> </table> | <u>Pins D/F</u> | <u>Pins C</u> | 4 to 6 | 5 to 8 | 12 to 10 | 15 to 13 | - | 50 | ns |
| <u>Pins D/F</u> | <u>Pins C</u> | | | | | | | | | | | | | |
| 4 to 6 | 5 to 8 | | | | | | | | | | | | | |
| 12 to 10 | 15 to 13 | | | | | | | | | | | | | |
| 92 to 93 | Propagation Delay Low to High (CLR to Q) | t_{PLH2} | 3003 | 4(j) | V_{IN} (Under Test) = Pulse Generator V_{IN} (Remaining Inputs) = Figure 3(b) $V_{DD} = 4.5V, V_{SS} = 0V$ Note 4 <table style="margin-left: auto; margin-right: auto; border-collapse: collapse;"> <tr> <td style="border-bottom: 1px solid black; padding: 0 5px;"><u>Pins D/F</u></td> <td style="border-bottom: 1px solid black; padding: 0 5px;"><u>Pins C</u></td> </tr> <tr> <td style="padding: 0 5px;">3 to 7</td> <td style="padding: 0 5px;">4 to 9</td> </tr> <tr> <td style="padding: 0 5px;">13 to 9</td> <td style="padding: 0 5px;">17 to 12</td> </tr> </table> | <u>Pins D/F</u> | <u>Pins C</u> | 3 to 7 | 4 to 9 | 13 to 9 | 17 to 12 | - | 39 | ns |
| <u>Pins D/F</u> | <u>Pins C</u> | | | | | | | | | | | | | |
| 3 to 7 | 4 to 9 | | | | | | | | | | | | | |
| 13 to 9 | 17 to 12 | | | | | | | | | | | | | |
| 94 to 95 | Propagation Delay High to Low (CLR to Q) | t_{PHL2} | 3003 | 4(j) | V_{IN} (Under Test) = Pulse Generator V_{IN} (Remaining Inputs) = Figure 3(b) $V_{DD} = 4.5V, V_{SS} = 0V$ Note 4 <table style="margin-left: auto; margin-right: auto; border-collapse: collapse;"> <tr> <td style="border-bottom: 1px solid black; padding: 0 5px;"><u>Pins D/F</u></td> <td style="border-bottom: 1px solid black; padding: 0 5px;"><u>Pins C</u></td> </tr> <tr> <td style="padding: 0 5px;">3 to 6</td> <td style="padding: 0 5px;">4 to 8</td> </tr> <tr> <td style="padding: 0 5px;">13 to 10</td> <td style="padding: 0 5px;">17 to 13</td> </tr> </table> | <u>Pins D/F</u> | <u>Pins C</u> | 3 to 6 | 4 to 8 | 13 to 10 | 17 to 13 | - | 39 | ns |
| <u>Pins D/F</u> | <u>Pins C</u> | | | | | | | | | | | | | |
| 3 to 6 | 4 to 8 | | | | | | | | | | | | | |
| 13 to 10 | 17 to 13 | | | | | | | | | | | | | |

NOTES: See Page 20.

TABLE 2 - ELECTRICAL MEASUREMENTS AT ROOM TEMPERATURE - a.c. PARAMETERS (CONT'D)

| NO. | CHARACTERISTICS | SYMBOL | TEST METHOD MIL-STD 883 | TEST FIG. | TEST CONDITIONS (PINS UNDER TEST D/F = DIP AND FP C = CCP) | LIMITS | | UNIT |
|------------------|--------------------------------|-----------|-------------------------------|-----------|---|--------|-----|------|
| | | | | | | MIN | MAX | |
| 96 to 99 | Transition Time Low to High | t_{TLH} | 3004 | 4(j) | V_{IN} (Under Test) = Pulse Generator V_{IN} (Remaining Inputs) = Figure 3(b) $V_{DD} = 4.5V, V_{SS} = 0V$ Note 4 (Pins D/F 6-7-9-10) (Pins C 8-9-12-13) | - | 15 | ns |
| 100 to 103 | Transition Time High to Low | t_{THL} | 3004 | 4(j) | V_{IN} (Under Test) = Pulse Generator V_{IN} (Remaining Inputs) = Figure 3(b) $V_{DD} = 4.5V, V_{SS} = 0V$ Note 4 (Pins D/F 6-7-9-10) (Pins C 8-9-12-13) | - | 15 | ns |

NOTES: See Page 20.

**TABLE 3 - ELECTRICAL MEASUREMENTS AT HIGH AND LOW TEMPERATURES**

| NO. | CHARACTERISTICS | SYMBOL | TEST METHOD MIL-STD 883 | TEST FIG. | TEST CONDITIONS (PINS UNDER TEST D/F = DIP AND FP C = CCP) | LIMITS | | UNIT |
|----------------|----------------------------|--------------|-------------------------------|-----------|---|--------|-----|---------|
| | | | | | | MIN | MAX | |
| 1 | Functional Test 1 | - | - | 3(b) | Verify Truth Table without Load. $V_{IL} = 0.3V, V_{IH} = 1.5V$ $V_{DD} = 2.0V, V_{SS} = 0V$ $t_r = t_f < 1.0\mu s$ (CLR only) $f = 10kHz$ (min) Note 1 | - | - | - |
| 2 | Functional Test 2 | - | - | 3(b) | Verify Truth Table without Load. $V_{IL} = 0.9V, V_{IH} = 3.15V$ $V_{DD} = 4.5V, V_{SS} = 0V$ $t_r = t_f < 500ns$ (CLR only) $f = 10kHz$ (min) Note 1 | - | - | - |
| 3 | Functional Test 3 | - | - | 3(b) | Verify Truth Table without Load. $V_{IL} = 1.2V, V_{IH} = 4.2V$ $V_{DD} = 6.0V, V_{SS} = 0V$ $t_r = t_f < 400ns$ (CLR only) $f = 10kHz$ (min) Note 1 | - | - | - |
| 4 to 5 | Quiescent Current | I_{DD} | 3005 | 4(a) | $V_{IL} = 0V, V_{IH} = 6.0V$ $V_{DD} = 6.0V, V_{SS} = 0V$ All Outputs Open Note 2 (Pin D/F 16) (Pin C 20) | - | 8.0 | μA |
| 6 to 7 | Active Supply Current 1 | $I_{DD(S1)}$ | 3005 | 4(a) | $V_{IL} = 0V, V_{IH} = 2.0V$ $V_H = 1.0V$ $V_{DD} = 2.0V, V_{SS} = 0V$ All Outputs Open Note 2 (Pin D/F 16) (Pin C 20) | - | 350 | μA |
| 8 to 9 | Active Supply Current 2 | $I_{DD(S2)}$ | 3005 | 4(a) | $V_{IL} = 0V, V_{IH} = 4.5V$ $V_H = 2.25V$ $V_{DD} = 4.5V, V_{SS} = 0V$ All Outputs Open Note 2 (Pin D/F 16) (Pin C 20) | - | 1.0 | mA |
| 10 to 11 | Active Supply Current 3 | $I_{DD(S3)}$ | 3005 | 4(a) | $V_{IL} = 0V, V_{IH} = 6.0V$ $V_H = 3.0V$ $V_{DD} = 6.0V, V_{SS} = 0V$ All Outputs Open Note 2 (Pin D/F 16) (Pin C 20) | - | 1.7 | mA |

NOTES: See Page 20.

**TABLE 3 - ELECTRICAL MEASUREMENTS AT HIGH AND LOW TEMPERATURES (CONT'D)**

| NO. | CHARACTERISTICS | SYMBOL | TEST METHOD MIL-STD 883 | TEST FIG. | TEST CONDITIONS (PINS UNDER TEST D/F = DIP AND FP C = CCP) | LIMITS | | UNIT |
|----------------|-------------------------------|-----------|-------------------------------|-----------|---|--------|------|---------|
| | | | | | | MIN | MAX | |
| 12 to 17 | Input Current Low Level 1 | I_{IL1} | 3009 | 4(b) | V_{IN} (Under Test) = 0V V_{IN} (Remaining Inputs) = 6.0V V_{DD} = 6.0V, V_{SS} = 0V (Pins D/F 3-4-5-11-12-13) (Pins C 4-5-7-14-15-17) | - | -1.0 | μ A |
| 18 to 19 | Input Current Low Level 2 | I_{IL2} | 3009 | 4(b) | V_{IN} (Under Test) = 0V V_{IN} (Remaining Inputs) = 6.0V V_{DD} = 6.0V, V_{SS} = 0V (Pins D/F 2-14) (Pins C 3-18) | - | -10 | μ A |
| 20 to 25 | Input Current High Level 1 | I_{IH1} | 3010 | 4(c) | V_{IN} (Under Test) = 6.0V V_{IN} (Remaining Inputs) = 0V V_{DD} = 6.0V, V_{SS} = 0V (Pins D/F 3-4-5-11-12-13) (Pins C 4-5-7-14-15-17) | - | 1.0 | μ A |
| 26 to 27 | Input Current High Level 2 | I_{IH2} | 3010 | 4(c) | V_{IN} (Under Test) = 6.0V V_{IN} (Remaining Inputs) = 0V V_{DD} = 6.0V, V_{SS} = 0V (Pins D/F 2-14) (Pins C 3-18) | - | 10 | μ A |
| 28 to 31 | Output Voltage Low Level 1 | V_{OL1} | 3007 | 4(d) | V_{IL} = 0.3V, V_{IH} = 1.5V I_{OL} = 20 μ A V_{DD} = 2.0V, V_{SS} = 0V (Pins D/F 6-7-9-10) (Pins C 8-9-12-13) | - | 0.1 | V |
| 32 to 35 | Output Voltage Low Level 2 | V_{OL2} | 3007 | 4(d) | V_{IL} = 0.9V, V_{IH} = 3.15V I_{OL} = 20 μ A V_{DD} = 4.5V, V_{SS} = 0V (Pins D/F 6-7-9-10) (Pins C 8-9-12-13) | - | 0.1 | V |
| 36 to 39 | Output Voltage Low Level 3 | V_{OL3} | 3007 | 4(d) | V_{IL} = 1.2V, V_{IH} = 4.2V I_{OL} = 20 μ A V_{DD} = 6.0V, V_{SS} = 0V (Pins D/F 6-7-9-10) (Pins C 8-9-12-13) | - | 0.1 | V |

NOTES: See Page 20.

**TABLE 3 - ELECTRICAL MEASUREMENTS AT HIGH AND LOW TEMPERATURES (CONT'D)**

| NO. | CHARACTERISTICS | SYMBOL | TEST METHOD MIL-STD 883 | TEST FIG. | TEST CONDITIONS (PINS UNDER TEST D/F = DIP AND FP C = CCP) | LIMITS | | UNIT |
|----------------|--------------------------------|-----------|-------------------------------|-----------|---|--------|-----|------|
| | | | | | | MIN | MAX | |
| 40 to 43 | Output Voltage Low Level 4 | V_{OL4} | 3007 | 4(d) | $V_{IL} = 0.9V, V_{IH} = 3.15V$ $I_{OL} = 4.0mA$ $V_{DD} = 4.5V, V_{SS} = 0V$ (Pins D/F 6-7-9-10) (Pins C 8-9-12-13) | - | 0.4 | V |
| 44 to 47 | Output Voltage Low Level 5 | V_{OL5} | 3007 | 4(d) | $V_{IL} = 1.2V, V_{IH} = 4.2V$ $I_{OL} = 5.2mA$ $V_{DD} = 6.0V, V_{SS} = 0V$ (Pins D/F 6-7-9-10) (Pins C 8-9-12-13) | - | 0.4 | V |
| 48 to 51 | Output Voltage High Level 1 | V_{OH1} | 3006 | 4(e) | $V_{IL} = 0.3V, V_{IH} = 1.5V$ $I_{OH} = -20\mu A$ $V_{DD} = 2.0V, V_{SS} = 0V$ (Pins D/F 6-7-9-10) (Pins C 8-9-12-13) | 1.9 | - | V |
| 52 to 55 | Output Voltage High Level 2 | V_{OH2} | 3006 | 4(e) | $V_{IL} = 0.9V, V_{IH} = 3.15V$ $I_{OH} = -20\mu A$ $V_{DD} = 4.5V, V_{SS} = 0V$ (Pins D/F 6-7-9-10) (Pins C 8-9-12-13) | 4.4 | - | V |
| 56 to 59 | Output Voltage High Level 3 | V_{OH3} | 3006 | 4(e) | $V_{IL} = 1.2V, V_{IH} = 4.2V$ $I_{OH} = -20\mu A$ $V_{DD} = 6.0V, V_{SS} = 0V$ (Pins D/F 6-7-9-10) (Pins C 8-9-12-13) | 5.9 | - | V |
| 60 to 63 | Output Voltage High Level 4 | V_{OH4} | 3006 | 4(e) | $V_{IL} = 0.9V, V_{IH} = 3.15V$ $I_{OH} = -4.0mA$ $V_{DD} = 4.5V, V_{SS} = 0V$ (Pins D/F 6-7-9-10) (Pins C 8-9-12-13) | 3.7 | - | V |
| 64 to 67 | Output Voltage High Level 5 | V_{OH5} | 3006 | 4(e) | $V_{IL} = 1.2V, V_{IH} = 4.2V$ $I_{OH} = -5.2mA$ $V_{DD} = 6.0V, V_{SS} = 0V$ (Pins D/F 6-7-9-10) (Pins C 8-9-12-13) | 5.2 | - | V |

NOTES: See Page 20.



TABLE 3 - ELECTRICAL MEASUREMENTS AT HIGH AND LOW TEMPERATURES (CONT'D)

| NO. | CHARACTERISTICS | SYMBOL | TEST METHOD MIL-STD 883 | TEST FIG. | TEST CONDITIONS (PINS UNDER TEST D/F = DIP AND FP C = CCP) | LIMITS | | UNIT |
|----------------|---------------------------------------|-----------|-------------------------------|-----------|---|--------|------|------|
| | | | | | | MIN | MAX | |
| 70 to 75 | Input Clamp Voltage (to V_{SS}) | V_{IC1} | - | 4(h) | I_{IN} (Under Test) = -0.1mA V_{DD} = Open, V_{SS} = 0V All Other Pins Open (Pins D/F 3-4-5-11-12-13) (Pins C 4-5-7-14-15-17) | -0.1 | -1.2 | V |
| 76 to 81 | Input Clamp Voltage (to V_{DD}) | V_{IC2} | - | 4(h) | I_{IN} (Under Test) = 0.1mA V_{DD} = 0V, V_{SS} = Open, All Other Pins Open (Pins D/F 3-4-5-11-12-13) (Pins C 4-5-7-14-15-17) | 0.1 | 1.2 | V |

NOTES: See Page 20.

FIGURE 4 - CIRCUITS FOR ELECTRICAL MEASUREMENTS
FIGURE 4(a) - QUIESCENT AND ACTIVE SUPPLY CURRENT TEST TABLE

| PATTERN NO. | INPUTS | | | | | | | | | | OUTPUTS | | | | PACKAGE | D.C. SUPPLY | |
|-------------|--------|--------|--------|--------|--------|----------|----------|----------|----------|----------|---------|--------|---------|----------|----------------|-----------------|-----------------|
| | 1 2 | 2 3 | 3 4 | 4 5 | 5 7 | 11 14 | 12 15 | 13 17 | 14 18 | 15 19 | 6 8 | 7 9 | 9 12 | 10 13 | DIL, FP CCP | 8 10 | 16 20 |
| 1 | 0 | 0 | 0 | 0 | 0 | 0 | 0 | 0 | 0 | 0 | OPEN | | | | | V _{SS} | V _{DD} |
| 2 | 0 | 1 | 1 | 1 | 1 | 1 | 1 | 1 | 1 | 0 | OPEN | | | | | ↓ | ↓ |
| | 0 | H | 0 | 0 | 0 | 0 | 0 | 0 | 0 | 0 | OPEN | | | | | | |
| | 0 | H | 1 | 0 | 0 | 0 | 0 | 0 | 0 | 0 | OPEN | | | | | | |
| | 0 | H | 1 | 0 | 1 | 0 | 0 | 0 | 0 | 0 | OPEN | | | | | | |
| 3 | 0 | H | 1 | 1 | 1 | 0 | 0 | 0 | 0 | 0 | OPEN | | | | | | |
| | 0 | 0 | 0 | 0 | 0 | 0 | 0 | 0 | H | 0 | OPEN | | | | | | |
| | 0 | 0 | 0 | 0 | 0 | 0 | 0 | 1 | H | 0 | OPEN | | | | | | |
| | 0 | 0 | 0 | 0 | 0 | 1 | 0 | 1 | H | 0 | OPEN | | | | | | |
| 4 | 0 | 0 | 0 | 0 | 0 | 1 | 1 | 1 | H | 0 | OPEN | | | | | | |

NOTES

- Figure 4(a) illustrates one series of test patterns. Any other pattern series must be agreed with the Qualifying Space Agency and shall be included as an Appendix.
- Logic Level Definitions: 1 = $V_{IH} = V_{DD}$, 0 = $V_{IL} = V_{SS}$, H = $V_{DD}/2$.
- Patterns 1 and 2 shall be used for the measurement of I_{DD} and all remaining patterns shall be used for the measurement of each $I_{DD(s)}$.

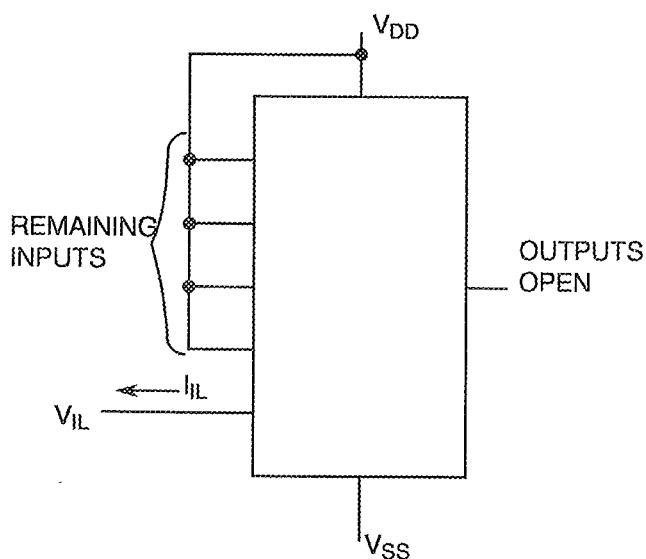
FIGURE 4(b) - INPUT CURRENT LOW LEVEL

NOTES

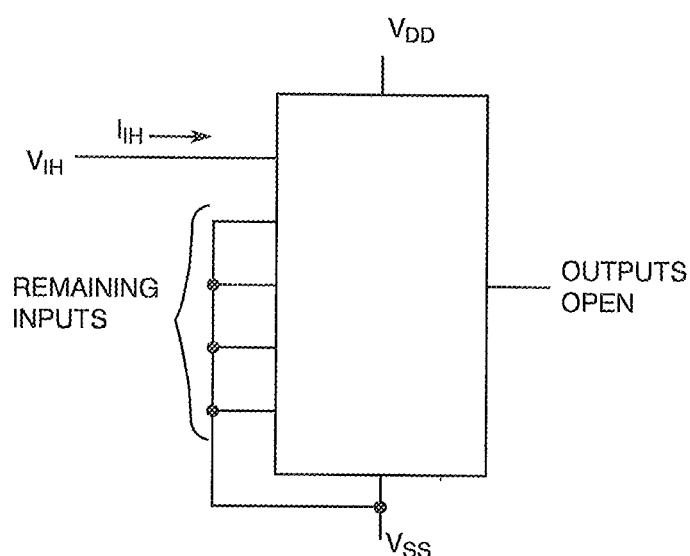
- Each input to be tested separately.

FIGURE 4(c) - INPUT CURRENT HIGH LEVEL

NOTES

- Each input to be tested separately.

FIGURE 4 - CIRCUITS FOR ELECTRICAL MEASUREMENTS (CONTINUED)

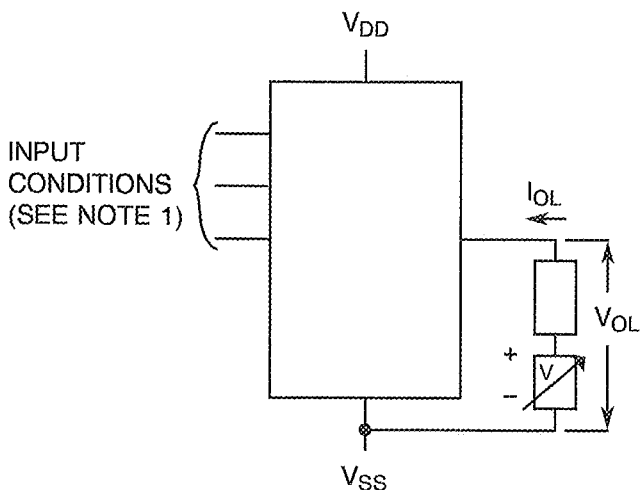
FIGURE 4(d) - OUTPUT VOLTAGE LOW LEVEL



NOTES

1. $V_{IN} = V_{IL}$ (max.) and/or V_{IH} (min.) as per Truth Table to give V_{OL} .
2. Each output to be tested separately.

FIGURE 4(e) - OUTPUT VOLTAGE HIGH LEVEL

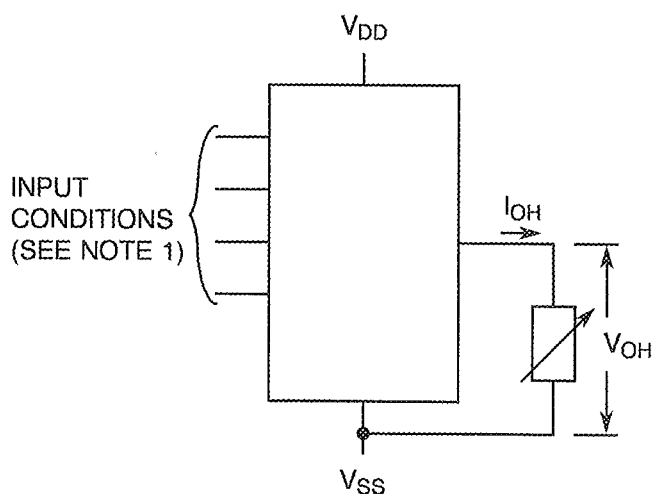

NOTES

1. $V_{IN} = V_{IL}$ (max.) and/or V_{IH} (min.) as per Truth Table to give V_{OH} .
2. Each output to be tested separately.

FIGURE 4(f) - THRESHOLD VOLTAGE N-CHANNEL

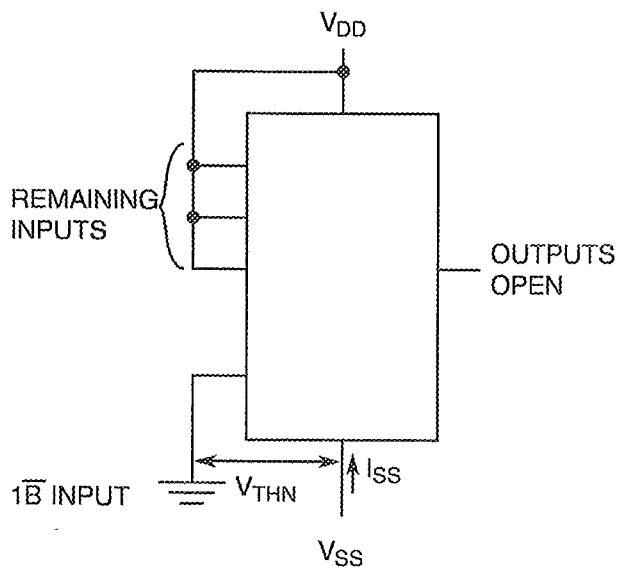

FIGURE 4(g) - THRESHOLD VOLTAGE P-CHANNEL

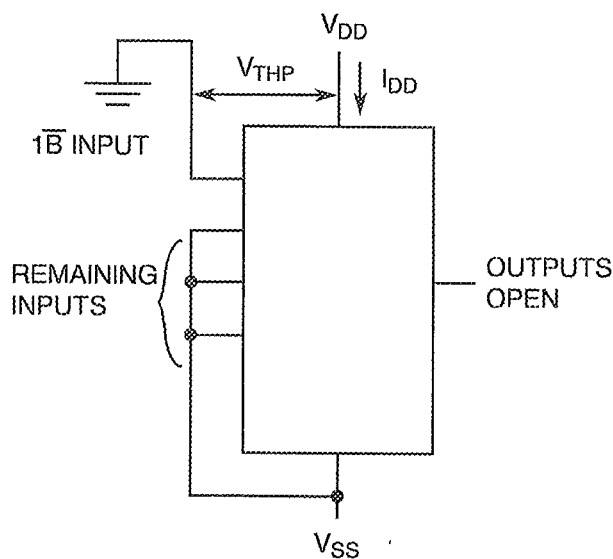
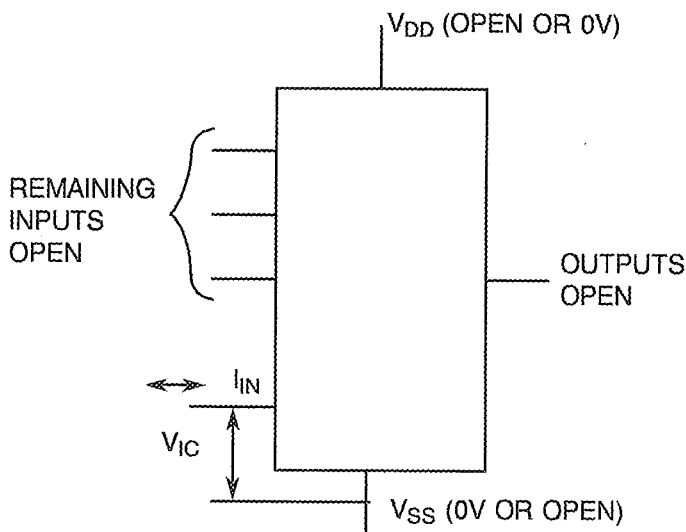

FIGURE 4 - CIRCUITS FOR ELECTRICAL MEASUREMENTS (CONTINUED)

FIGURE 4(h) - INPUT CLAMP VOLTAGE



NOTES 1. Each input to be tested separately.

FIGURE 4(i) - INPUT CAPACITANCE

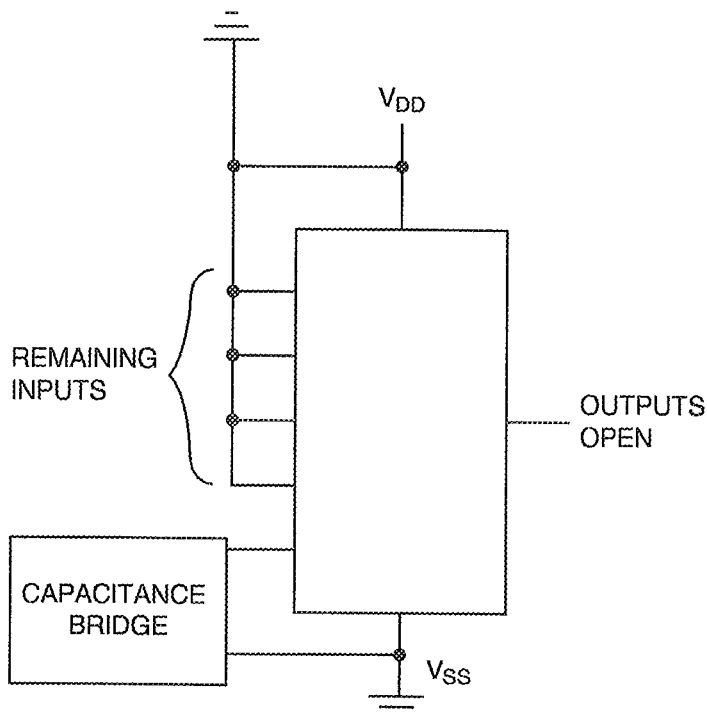

NOTES 1. Each input to be tested separately.
2. $f = 100\text{kHz}$ to 1MHz .

FIGURE 4 - CIRCUITS FOR ELECTRICAL MEASUREMENTS (CONTINUED)

FIGURE 4(i) - PROPAGATION DELAY AND TRANSITION TIME

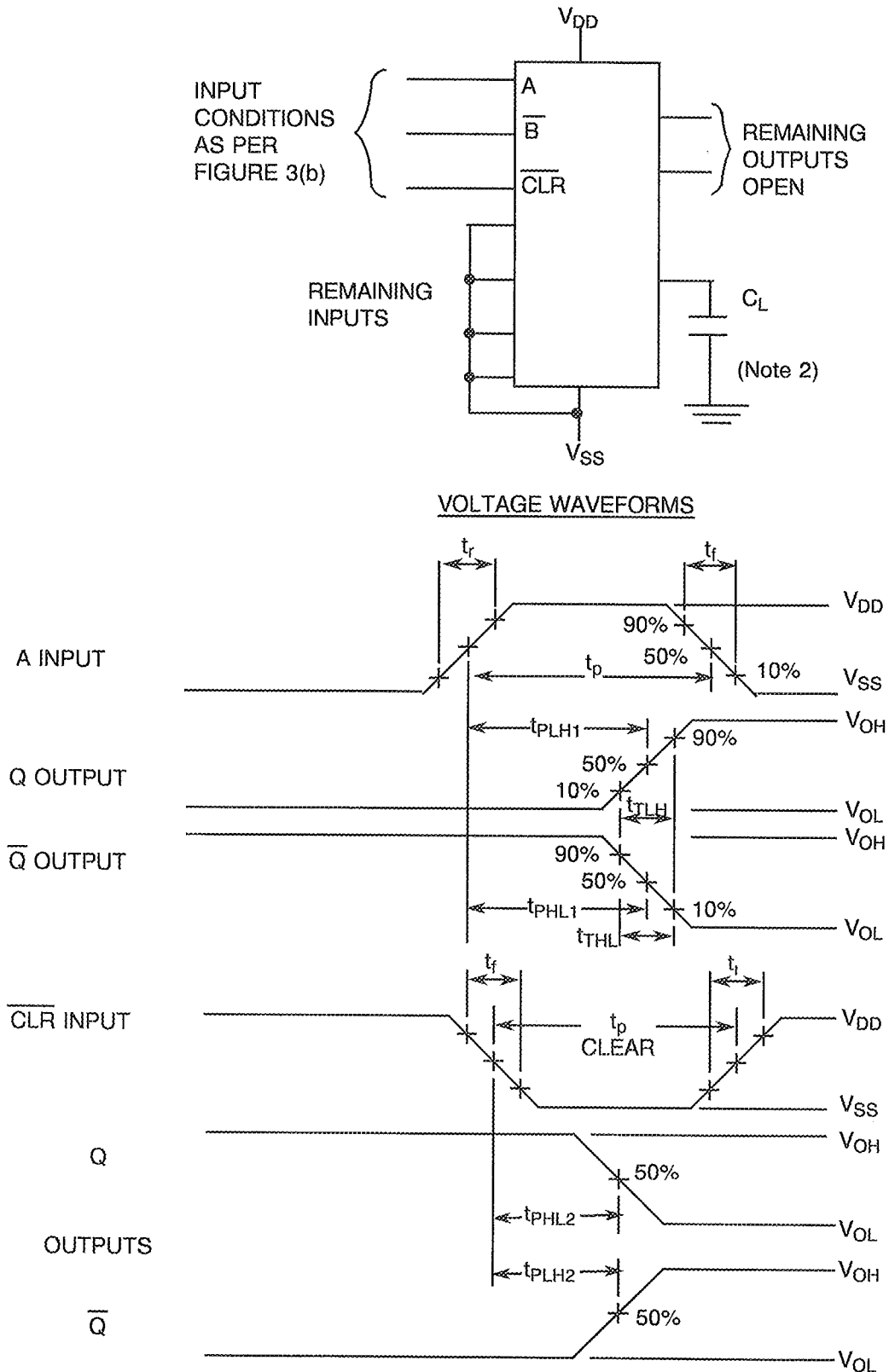

NOTES

1. Pulse Generator - V_p = 0 to V_{DD}, t_r and t_f ≤ 6ns, f = 1.0MHz minimum, 50% Duty Cycle, Z_{OUT} = 50Ω.
2. C_L = 50pF ± 5% including scope, wiring and stray capacitance without package in test fixture.

**TABLE 4 - PARAMETER DRIFT VALUES**

| NO. | CHARACTERISTICS | SYMBOL | SPEC. AND/OR TEST METHOD | TEST CONDITIONS | CHANGE LIMITS (Δ) | UNIT |
|----------|-----------------------------|--------------|--------------------------|-----------------|----------------------------|---------|
| 4 to 5 | Quiescent Current | I_{DD} | As per Table 2 | As per Table 2 | ± 120 | nA |
| 8 to 9 | Active Supply Current 2 | $I_{DD(S2)}$ | As per Table 2 | As per Table 2 | ± 180 | μ A |
| 12 to 17 | Input Current Low Level 1 | I_{IL1} | As per Table 2 | As per Table 2 | ± 20 | nA |
| 18 to 19 | Input Current Low Level 2 | I_{IL2} | As per Table 2 | As per Table 2 | ± 150 | nA |
| 20 to 25 | Input Current High Level 1 | I_{IH1} | As per Table 2 | As per Table 2 | ± 20 | nA |
| 26 to 27 | Input Current High Level 2 | I_{IH2} | As per Table 2 | As per Table 2 | ± 150 | nA |
| 40 to 43 | Output Voltage Low Level 4 | V_{OL4} | As per Table 2 | As per Table 2 | ± 0.026 | V |
| 60 to 63 | Output Voltage High Level 4 | V_{OH4} | As per Table 2 | As per Table 2 | ± 0.2 | V |
| 68 | Threshold Voltage N-Channel | V_{THN} | As per Table 2 | As per Table 2 | ± 0.3 | V |
| 69 | Threshold Voltage P-Channel | V_{THP} | As per Table 2 | As per Table 2 | ± 0.3 | V |

**TABLE 5(a) - CONDITIONS FOR BURN-IN HIGH TEMPERATURE REVERSE BIAS, N-CHANNELS**

| NO. | CHARACTERISTICS | SYMBOL | CONDITION | UNIT |
|-----|---|-----------|------------------|-------|
| 1 | Ambient Temperature | T_{amb} | + 125(+ 0-5) | °C |
| 2 | Outputs - (Pins D/F 6-7-9-10) (Pins C 8-9-12-13) | V_{OUT} | Open or V_{SS} | - |
| 3 | Inputs - (Pins D/F 2-3-4-5-11-12-13-14) (Pins C 3-4-5-7-14-15-17-18) | V_{IN} | V_{SS} | V |
| 4 | Inputs - (Pins D/F 1-15) (Pins C 2-19) | V_{IN} | Open | V |
| 5 | Positive Supply Voltage (Pin D/F 16) (Pin C 20) | V_{DD} | 6.0(+ 0-0.5) | V |
| 6 | Negative Supply Voltage (Pin D/F 8) (Pin C 10) | V_{SS} | 0 | V |
| 7 | Duration | t | 72 | Hours |

NOTES

1. Input Protection Resistor = 680 Ω min. to 47k Ω max.
2. Output Load = 1k Ω min. to 10k Ω max.

TABLE 5(b) - CONDITIONS FOR BURN-IN HIGH TEMPERATURE REVERSE BIAS, P-CHANNELS

| NO. | CHARACTERISTICS | SYMBOL | CONDITION | UNIT |
|-----|---|-----------|------------------|-------|
| 1 | Ambient Temperature | T_{amb} | + 125(+ 0-5) | °C |
| 2 | Outputs - (Pins D/F 6-7-9-10) (Pins C 8-9-12-13) | V_{OUT} | Open or V_{DD} | - |
| 3 | Inputs - (Pins D/F 2-3-4-5-11-12-13-14) (Pins C 3-4-5-7-14-15-17-18) | V_{IN} | V_{DD} | V |
| 4 | Inputs - (Pins D/F 1-15) (Pins C 2-19) | V_{IN} | Open | V |
| 5 | Positive Supply Voltage (Pin D/F 16) (Pin C 20) | V_{DD} | 6.0(+ 0-0.5) | V |
| 6 | Negative Supply Voltage (Pin D/F 8) (Pin C 10) | V_{SS} | 0 | V |
| 7 | Duration | t | 72 | Hours |

NOTES

1. Input Protection Resistor = 680 Ω min. to 47k Ω max.
2. Output Load = 1k Ω min. to 10k Ω max.

TABLE 5(c) - CONDITIONS FOR POWER BURN-IN AND OPERATING LIFE TEST

| NO. | CHARACTERISTICS | SYMBOL | CONDITIONS | UNIT |
|-----|---|--------------------------|--|------|
| 1 | Ambient Temperature | T_{amb} | + 125(+ 0-5) | °C |
| 2 | Outputs - (Pins D/F 6-7-9-10) (Pins C 8-9-12-13) | V_{OUT} | V_{DD} | V |
| 3 | Inputs - (Pins D/F 2-14) (Pins C 3-18) | V_{IN} | V_{DD} | V |
| 4 | Inputs - (Pins D/F 4-11) (Pins C 5-14) | V_{IN} | V_{GEN1} | Vac |
| 5 | Inputs - (Pins D/F 5-12) (Pins C 7-15) | V_{IN} | V_{GEN2} | Vac |
| 6 | Input - (Pin D/F 3) (Pin C 4) | V_{IN} | V_{GEN3} | Vac |
| 7 | Input - (Pin D/F 13) (Pin C 17) | V_{IN} | V_{GEN4} | Vac |
| 8 | Inputs - (Pins D/F 1-15) (Pins C 2-19) | V_{IN} | Open | V |
| 9 | Pulse Voltage | V_{GEN} | 0V to V_{DD} | Vac |
| 10 | Pulse Frequency Square Wave | f_{GEN1} f_{GEN2} | 100k ± 10% 20k ± 10% $t_r = t_f \leq 400ns$ | Hz |
| 11 | Pulse Square Wave | GEN3 GEN4 | One 5µs negative pulse each 35ms One 5µs negative pulse each 35ms $t_r = t_f \leq 400ns$ | - |
| 12 | Positive Supply Voltage (Pin D/F 16) (Pin C 20) | V_{DD} | 6.0(+ 0-0.5) | V |
| 13 | Negative Supply Voltage (Pin D/F 8) (Pin C 10) | V_{SS} | 0 | V |

NOTES

1. Input Protection Resistor = 680Ω min. to 47kΩ max.
2. Output Load = 1kΩ min. to 10kΩ max.

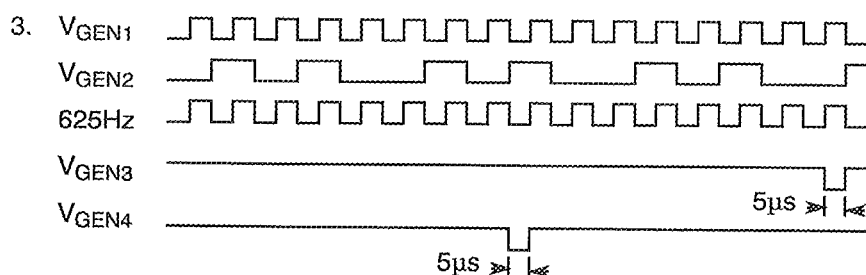
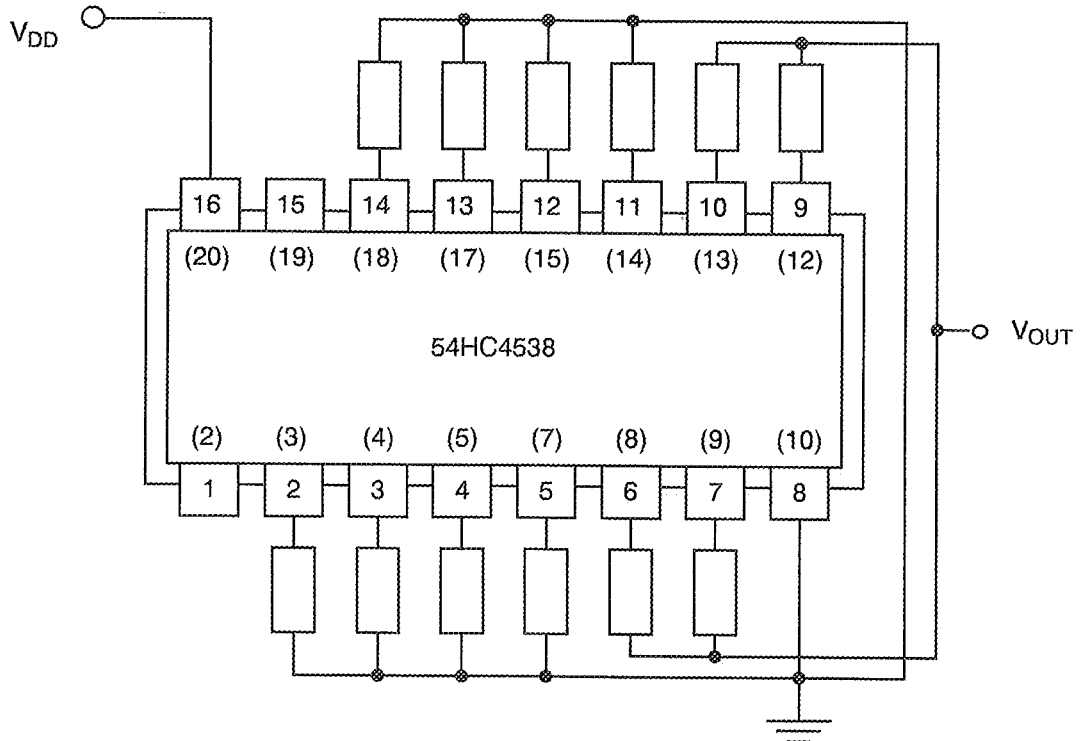
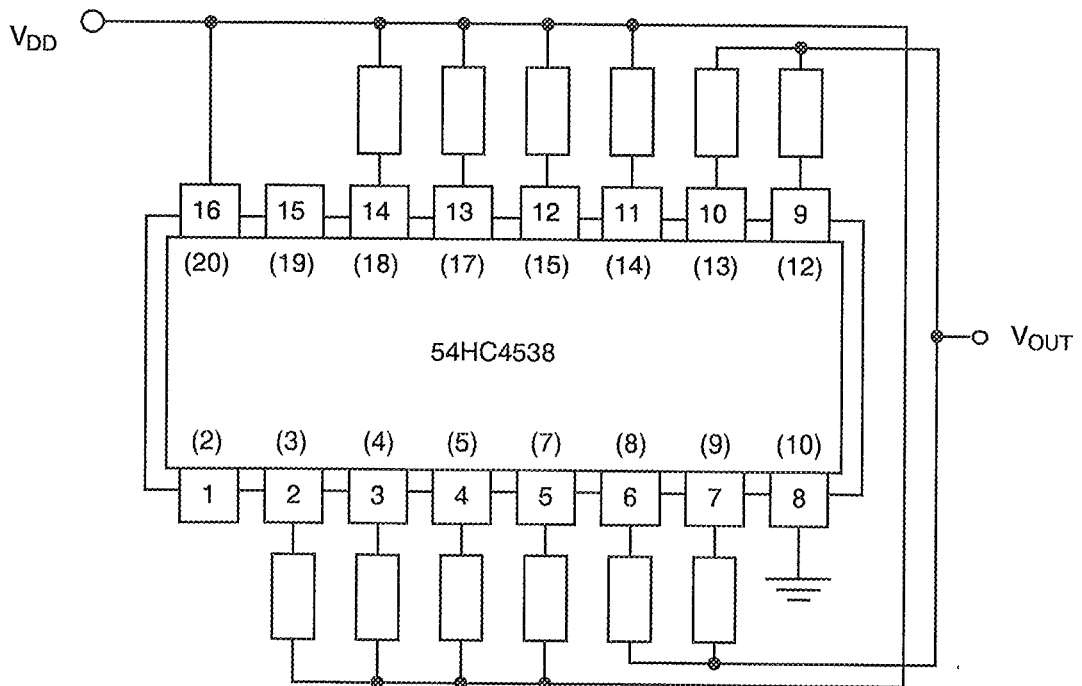

FIGURE 5(a) - ELECTRICAL CIRCUIT FOR BURN-IN HIGH TEMPERATURE REVERSE BIAS, N-CHANNELS

NOTES 1. Pin numbers in parenthesis are for the chip carrier package.

FIGURE 5(b) - ELECTRICAL CIRCUIT FOR BURN-IN HIGH TEMPERATURE REVERSE BIAS, P-CHANNELS



NOTES 1. Pin numbers in parenthesis are for the chip carrier package.

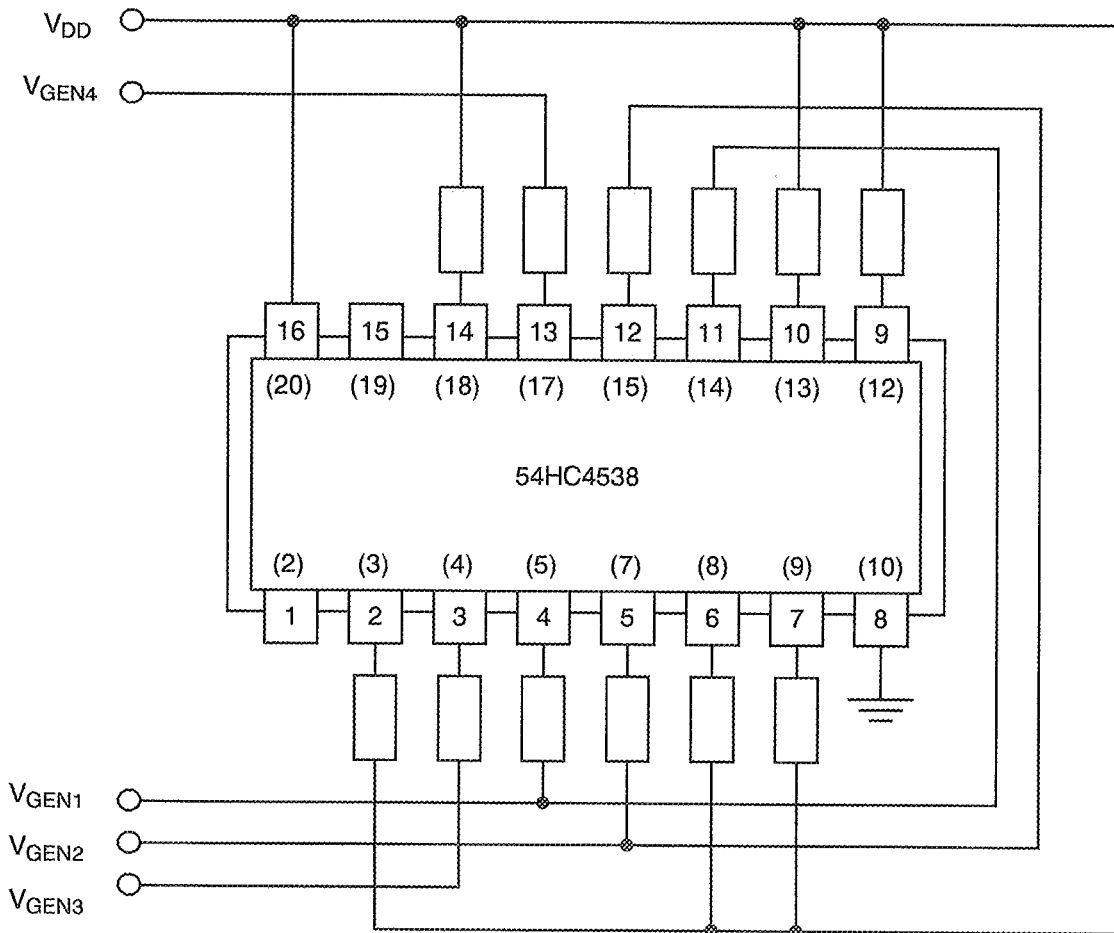

FIGURE 5(c) - ELECTRICAL CIRCUIT FOR POWER BURN-IN AND OPERATING LIFE TEST



NOTES 1. Pin numbers in parenthesis are for the chip carrier package.

| | | |
|--|--|--------------------|
|   | ESA/SCC Detail Specification No. 9207/008 | PAGE 36 ISSUE 1 |
|--|--|--------------------|

4.8 ENVIRONMENTAL AND ENDURANCE TESTS (CHARTS IV AND V OF ESA/SCC GENERIC SPECIFICATION NO. 9000)

4.8.1 Electrical Measurements on Completion of Environmental Tests

The parameters to be measured on completion of environmental tests are scheduled in Table 6. Unless otherwise stated, the measurements shall be performed at $T_{amb} = +22 \pm 3 \text{ }^\circ\text{C}$.

4.8.2 Electrical Measurements at Intermediate Points during Endurance Tests

The parameters to be measured at intermediate points during endurance tests are as scheduled in Table 6 of this specification. Unless otherwise stated, the measurements shall be performed at $T_{amb} = +22 \pm 3 \text{ }^\circ\text{C}$.

4.8.3 Electrical Measurements on Completion of Endurance Tests

The parameters to be measured on completion of endurance testing are as scheduled in Table 6 of this specification. Unless otherwise stated, the measurements shall be performed at $T_{amb} = +22 \pm 3 \text{ }^\circ\text{C}$.

4.8.4 Conditions for Operating Life Tests

The requirements for operating life testing are specified in Section 9 of ESA/SCC Generic Specification No. 9000. The conditions for operating life testing shall be as specified in Table 5(c) of this specification.

4.8.5 Electrical Circuits for Operating Life Tests

Circuits for use in performing the operating life tests are shown in Figure 5(c) of this specification.

4.8.6 Conditions for High Temperature Storage Test

The requirements for the high temperature storage test are specified in ESA/SCC Generic Specification No. 9000. The temperature to be applied shall be the maximum storage temperature specified in Table 1(b) of this specification.

4.9 TOTAL DOSE IRRADIATION TESTING

4.9.1 Application

If specified in Para. 4.2.1 of this specification, total dose irradiation testing shall be performed in accordance with the requirements of ESA/SCC Basic Specification No. 22900.

4.9.2 Bias Conditions

Continuous bias shall be applied during irradiation testing as shown in Figure 6 of this specification.

4.9.3 Electrical Measurements

The parameters to be measured prior to irradiation exposure are scheduled in Table 2 of this specification. Only devices which meet the requirements of Table 2 shall be included in the test sample.

The parameters to be measured during and on completion of irradiation testing are scheduled in Table 7 of this specification.

**TABLE 6 - ELECTRICAL MEASUREMENTS ON COMPLETION OF ENVIRONMENTAL TESTS AND AT INTERMEDIATE POINTS AND ON COMPLETION OF ENDURANCE TESTING**

| NO. | CHARACTERISTICS | SYMBOL | SPEC. AND/OR TEST METHOD | TEST CONDITIONS | CHANGE LIMITS (Δ) (NOTE 1) | ABSOLUTE | | UNIT |
|----------|-----------------------------|--------------|--------------------------|-----------------|-------------------------------------|----------|-------|---------|
| | | | | | | MIN | MAX | |
| 1 | Functional Test 1 | - | As per Table 2 | As per Table 2 | - | - | - | - |
| 2 | Functional Test 2 | - | As per Table 2 | As per Table 2 | - | - | - | - |
| 3 | Functional Test 3 | - | As per Table 2 | As per Table 2 | - | - | - | - |
| 4 to 5 | Quiescent Current | I_{DD} | As per Table 2 | As per Table 2 | ± 0.12 | - | 0.4 | μA |
| 6 to 7 | Active Supply Current 1 | $I_{DD(S1)}$ | As per Table 2 | As per Table 2 | ± 60 | - | 200 | μA |
| 8 to 9 | Active Supply Current 2 | $I_{DD(S2)}$ | As per Table 2 | As per Table 2 | ± 180 | - | 600 | μA |
| 10 to 11 | Active Supply Current 3 | $I_{DD(S3)}$ | As per Table 2 | As per Table 2 | ± 0.3 | - | 1.0 | mA |
| 12 to 17 | Input Current Low Level 1 | I_{IL1} | As per Table 2 | As per Table 2 | ± 20 | - | -50 | nA |
| 18 to 19 | Input Current Low Level 2 | I_{IL2} | As per Table 2 | As per Table 2 | ± 200 | - | -500 | nA |
| 20 to 25 | Input Current High Level 1 | I_{IH1} | As per Table 2 | As per Table 2 | ± 20 | - | 50 | nA |
| 26 to 27 | Input Current High Level 2 | I_{IH2} | As per Table 2 | As per Table 2 | ± 200 | - | 500 | nA |
| 40 to 43 | Output Voltage Low Level 4 | V_{OL4} | As per Table 2 | As per Table 2 | ± 0.026 | - | 0.26 | V |
| 44 to 47 | Output Voltage Low Level 5 | V_{OL5} | As per Table 2 | As per Table 2 | ± 0.026 | - | 0.26 | V |
| 60 to 63 | Output Voltage High Level 4 | V_{OH4} | As per Table 2 | As per Table 2 | ± 0.2 | 3.98 | - | V |
| 64 to 67 | Output Voltage High Level 5 | V_{OH5} | As per Table 2 | As per Table 2 | ± 0.2 | 5.48 | - | V |
| 68 | Threshold Voltage N-Channel | V_{THN} | As per Table 2 | As per Table 2 | ± 0.3 | -0.45 | -1.45 | V |
| 69 | Threshold Voltage P-Channel | V_{THP} | As per Table 2 | As per Table 2 | ± 0.3 | 0.45 | 1.35 | V |

NOTES 1. The change limits (Δ) are applicable to the Operating Life test only. The change in parameters between initial and end point measurements shall not exceed the limits given. In addition, the absolute limits shall not be exceeded.



FIGURE 6 - BIAS CONDITIONS FOR IRRADIATION TESTING

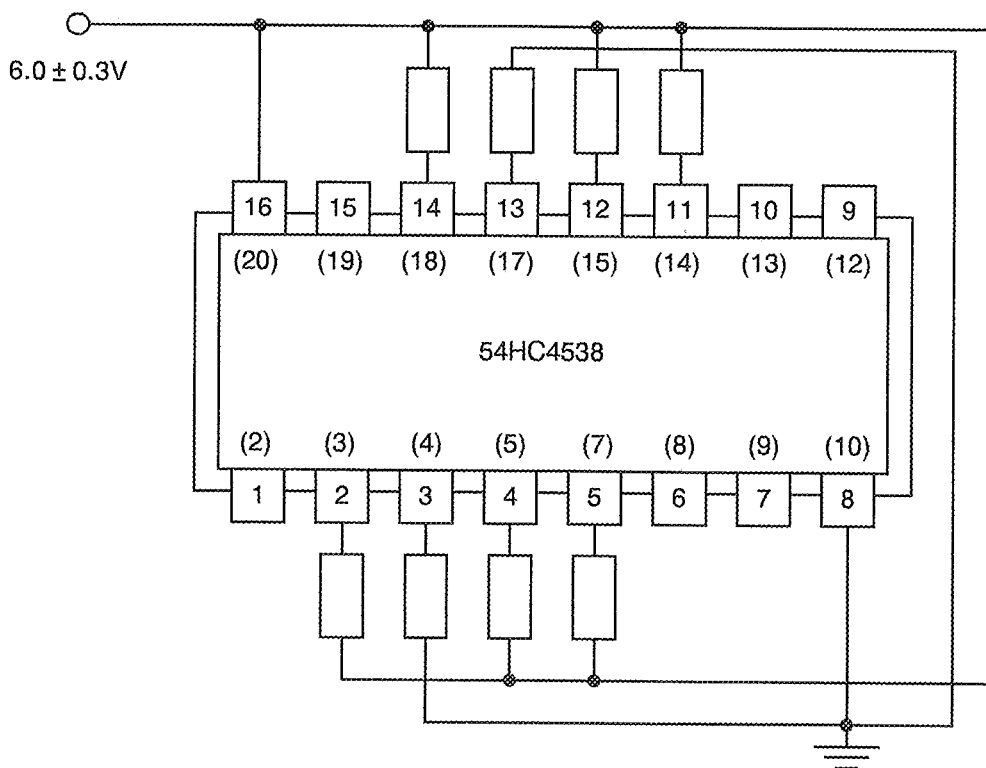



NOTES

1. Pin numbers in parenthesis are for the chip carrier package.
2. Input Protection Resistor = 680Ω min. to $47k\Omega$ max.

TABLE 7 - ELECTRICAL MEASUREMENTS DURING AND ON COMPLETION OF IRRADIATION TESTING

| NO. | CHARACTERISTICS | SYMBOL | SPEC. AND/OR TEST METHOD | TEST CONDITIONS | CHANGE LIMITS (Δ) | ABSOLUTE | | UNIT |
|--------|-----------------------------|-----------|--------------------------|-----------------|----------------------------|----------|------|---------|
| | | | | | | MIN | MAX | |
| 4 to 5 | Quiescent Current | I_{DD} | As per Table 2 | As per Table 2 | - | - | 40 | μA |
| 68 | Threshold Voltage N-Channel | V_{THN} | As per Table 2 | As per Table 2 | ± 0.6 | -0.4 | -1.5 | V |
| 69 | Threshold Voltage P-Channel | V_{THP} | As per Table 2 | As per Table 2 | ± 0.6 | 0.4 | 1.4 | V |

| | | | |
|---|--|-----------------|----------------------------|
|   | <p>ESA/SCC Detail Specification No. 9207/008</p> | <p>Rev. 'C'</p> | <p>PAGE 40 ISSUE 1</p> |
|---|--|-----------------|----------------------------|

APPENDIX 'A'

Page 1 of 1

AGREED DEVIATIONS FOR STMICROELECTRONICS (F)

| ITEMS AFFECTED | DESCRIPTION OF DEVIATIONS |
|----------------|--|
| Para. 4.2.3 | <p>Para. 7.1.1(b): Power Burn-in test is performed using STMicroelectronics Specification Ref.: 0019255.</p> <p>Para. 9.23, High Temperature Reverse Bias Burn-in: The temperature limits of MIL-STD-883, Para. 4.5.8(c) may be used.</p> <p>Para. 9.24, Power Burn-in: The temperature limits of MIL-STD-883, Para. 4.5.8(c) may be used.</p> |
| Para. 4.2.4 | Para. 9.21.1, Operating Life During Qualification Testing: The temperature limits of MIL-STD-883, Para. 4.5.8(c) may be used. |
| Para. 4.2.5 | Para. 9.21.2, Operating Life Test During Lot Acceptance Testing: The temperature limits of MIL-STD-883, Para. 4.5.8(c) may be used. |