



Pages 1 to 23

**CONNECTORS, MINIATURE, ELECTRICAL, CIRCULAR,
TRIPLE-START SELF-LOCKING COUPLING, SCOOP-PROOF,
HERMETIC RECEPTACLE AND FEEDTHROUGH,
BASED ON MIL-C-38999 SERIES III
ESCC Detail Specification No. 3401/057**

ISSUE 2

May 2004



Document Custodian: European Space Agency - see <https://escies.org>

	ESCC Detail Specification No. 3401/057		PAGE i ISSUE 2
---	---	--	-------------------

LEGAL DISCLAIMER AND COPYRIGHT

European Space Agency, Copyright © 2004. All rights reserved.

The European Space Agency disclaims any liability or responsibility, to any person or entity, with respect to any loss or damage caused, or alleged to be caused, directly or indirectly by the use and application of this ESCC publication.

This publication, without the prior permission of the European Space Agency and provided that it is not used for a commercial purpose, may be:

- copied in whole in any medium without alteration or modification.
- copied in part, in any medium, provided that the ESCC document identification, comprising the ESCC symbol, document number and document issue, is removed.



DOCUMENTATION CHANGE NOTICE

(Refer to <https://escies.org> for ESCC DCR content)

DCR No.	CHANGE DESCRIPTION
107	Specification upissued to incorporate editorial and technical changes per DCR.



TABLE OF CONTENTS

	<u>Page</u>
1. <u>GENERAL</u>	5
1.1 Scope	5
1.2 Range of Components	5
1.3 Maximum Ratings	5
1.4 Parameter Derating Information	5
1.5 Physical Dimensions	5
2. <u>APPLICABLE DOCUMENTS</u>	5
3. <u>TERMS, DEFINITIONS, ABBREVIATIONS, SYMBOLS AND UNITS</u>	5
4. <u>REQUIREMENTS</u>	14
4.1 General	14
4.2 Deviations from Generic Specification	14
4.2.1 Deviations from Special In-process Controls	14
4.2.2 Deviations from Final Production Tests	14
4.2.3 Deviations from Burn-in and Electrical Measurements	14
4.2.4 Deviations from Qualification Tests	14
4.2.5 Deviations from Lot Acceptance Tests	15
4.3 Mechanical Requirements	15
4.3.1 Dimension Check	15
4.3.2 Weight	15
4.3.3 Contact Capability	15
4.3.4 Contact Retention	15
4.3.5 Mating and Unmating Forces	15
4.3.6 Insert Retention	15
4.3.7 Jackscrew Retention	15
4.3.8 Contact Insertion and Withdrawal Forces	15
4.3.9 Engagement and Separation Forces	15
4.3.10 Oversize Pin Exclusion	15
4.3.11 Probe Damage	15
4.3.12 Solderability	15
4.4 Materials and Finishes	16
4.4.1 Shell, Coupling Ring and Nuts	16
4.4.2 Inserts	16
4.4.3 Contacts	16
4.4.4 Contact Retaining Clip	16
4.4.5 Guiding and Locking Devices	16
4.4.6 Magnetism Level	16
4.5 Marking	16
4.5.1 General	16
4.5.2 Contact Identification	16
4.5.3 The ESCC Component Number	16
4.5.4 Characteristics	17
4.5.5 Traceability Information	18
4.5.6 Marking of Small Components	18
4.6 Electrical Measurements	19
4.6.1 Electrical Measurements at Room Temperature	19
4.6.2 Electrical Measurements at High and Low Temperatures	19
4.6.3 Circuit for Electrical Measurements	19
4.7 Burn-in and Electrical Measurements	19
4.8 Environmental and Endurance Tests	19
4.8.1 Measurements and Inspections on Completion of Environmental Tests	19
4.8.2 Measurements and Inspections at Intermediate Points during Endurance Tests	19
4.8.3 Measurements and Inspections on Completion of Endurance Tests	19
4.8.4 Conditions for Operating Life Test	19

	<p style="text-align: center;">ESCC Detail Specification No. 3401/057</p>		<p>PAGE 4 ISSUE 2</p>
--	---	--	---------------------------

	<u>Page</u>
4.8.5 Electrical Circuits for Operating Life Test	19
4.8.6 Conditions for High Temperature Storage Test	19

TABLES

1(a) Range of Components	6
1(b) Maximum Ratings	7
2 Electrical Measurements at Room Temperature	20
3 Not applicable	N/A
4 Not applicable	N/A
5 Not applicable	N/A
6 Measurements and Inspections on Completion of Environmental and Endurance Tests	21

FIGURES

1 Parameter Derating Information	7
2 Physical Dimensions	8
2(a) Physical Dimensions - Receptables and Plugs	8
2(b) Physical Dimensions - Contact Arrangements	11
2(c) Physical Dimensions - Clocking Positions	13

APPENDICES (Applicable to specific Manufacturers only)

None.

	<p style="text-align: center;">ESCC Detail Specification No. 3401/057</p>	<p>PAGE 5 ISSUE 2</p>
--	---	---------------------------

1. **GENERAL**

1.1 **SCOPE**

This specification details the ratings, physical and electrical characteristics, test and inspection data for Connectors, Miniature, Electrical, Circular, Triple-Start Self-Locking Coupling, Scoop-proof, Hermetic Receptacle and Feedthrough, based on MIL-C-38999 Series III.

It shall be read in conjunction with:

- ESCC Generic Specification No. 3401, Connectors, Electrical, Non-Filtered, Circular and Rectangular.
- ESCC Detail Specification No. 3401/056, Connectors, Electrical, Circular, Triple-Start Self-Locking Coupling, Scoop-proof, Removable Crimp Contacts, Based on MIL-C-38999 Series III.

the requirements of which are supplemented herein.

1.2 **RANGE OF COMPONENTS**

The different sizes of connectors specified herein, which are also covered by this specification, together with their mechanical characteristics, are given in Table 1(a).

1.3 **MAXIMUM RATINGS**

The maximum ratings, which shall not be exceeded at any time during use or storage, applicable to the connector savers specified herein, are scheduled in Table 1(b).

1.4 **PARAMETER DERATING INFORMATION**

The applicable derating information for the connectors specified herein is shown in Figure 1.

1.5 **PHYSICAL DIMENSIONS**

The physical dimensions of the connectors specified herein are shown in Figure 2.

2. **APPLICABLE DOCUMENTS**

The following documents form part of this specification and shall be read in conjunction with it:-

- (a) ESCC Generic Specification No. 3401, Connectors, Electrical, Non-Filtered, Circular and Rectangular.
- (b) ESCC Detail Specification No. 3401/056, Connectors, Electrical, Circular, Triple-Start Self-Locking Coupling, Scoop-proof, Removable Crimp Contacts, Based on MIL-C-38999 Series III.
- (c) MIL-STD-1560, Insert Arrangements for MIL-C-38999 and MIL-C-27599 Electrical Circular Connectors.
- (d) MIL-STD-1651, Insert Arrangements for MIL-C-5015, MIL-C-22992 and MIL-C-83723 Electrical Connectors.

3. **TERMS, DEFINITIONS, ABBREVIATIONS, SYMBOLS AND UNITS**

For the purpose of this specification, the terms, definitions, abbreviations, symbols and units specified in ESCC Basic Specification No. 21300 shall apply.



TABLE 1(a) - RANGE OF COMPONENTS

SHELL SIZE	MAX. WEIGHT (g)				TIGHT. TORQUE FOR MTG NUT RECEPTACLE 07 MAX (Nm)	TIGHT. TORQUE FOR MTG NUT FEEDTHROUGH 77 MAX (Nm)
	SHELL TYPE					
	00H	01H	07H	77H		
09	25	20	33	90	6.3	11.5
11	35	30	44	115	8.4	15.7
13	42	37	52	140	10.5	16.8
15	48	42	58	160	13.6	17.9
17	57	50	68	200	16.8	20
19	62	55	74	220	18.9	23.1
21	70	63	83	260	21	25.2
23	75	68	85	290	23.1	28.3
25	83	75	92	320	25.2	30.4

SHELL TYPE	CONTACT SIZE	TYPE	MATING END SIZE	SOLDER BUCKET SIZE	ACCEPT WIRE
RECEPTACLE	22D	Male	22	22	22-24-26
	20	Male	20	20	20-22-24
FEEDTHROUGH	22D	Male	22 (1)	N/A	None
	20	Male	20 (1)	N/A	None
	16	Male	16 (1)	N/A	None
	12	Male	12 (1)	N/A	None
	8	Male	8 (1)	N/A	None

NOTES

1. Identical on both sides of feedthrough.

TABLE 1(b) - MAXIMUM RATINGS

NO	CHARACTERISTICS	SYMBOL	MAXIMUM RATING	UNIT
1	Working Voltage (1) (Sea Level) Service rating M Service rating I Service rating II	U_R	325 450 575	Vrms
2	Rated Current Contact size 22D Contact size 20 Contact size 16 Contact size 12 Contact size 8	I_{CR}	3.0 5.0 10 17 33	A
3	Operating Temperature Range	T_{op}	- 65 to + 200	°C
4	Storage Temperature Range	T_{stg}	- 65 to + 200	°C
5	Tightening Torque for Mounting Nut Shells 07 and 77	T_q	See Table 1(a)	

NOTES

1. See Para. 4.5.4.3.

FIGURE 1 - PARAMETER DERATING INFORMATION

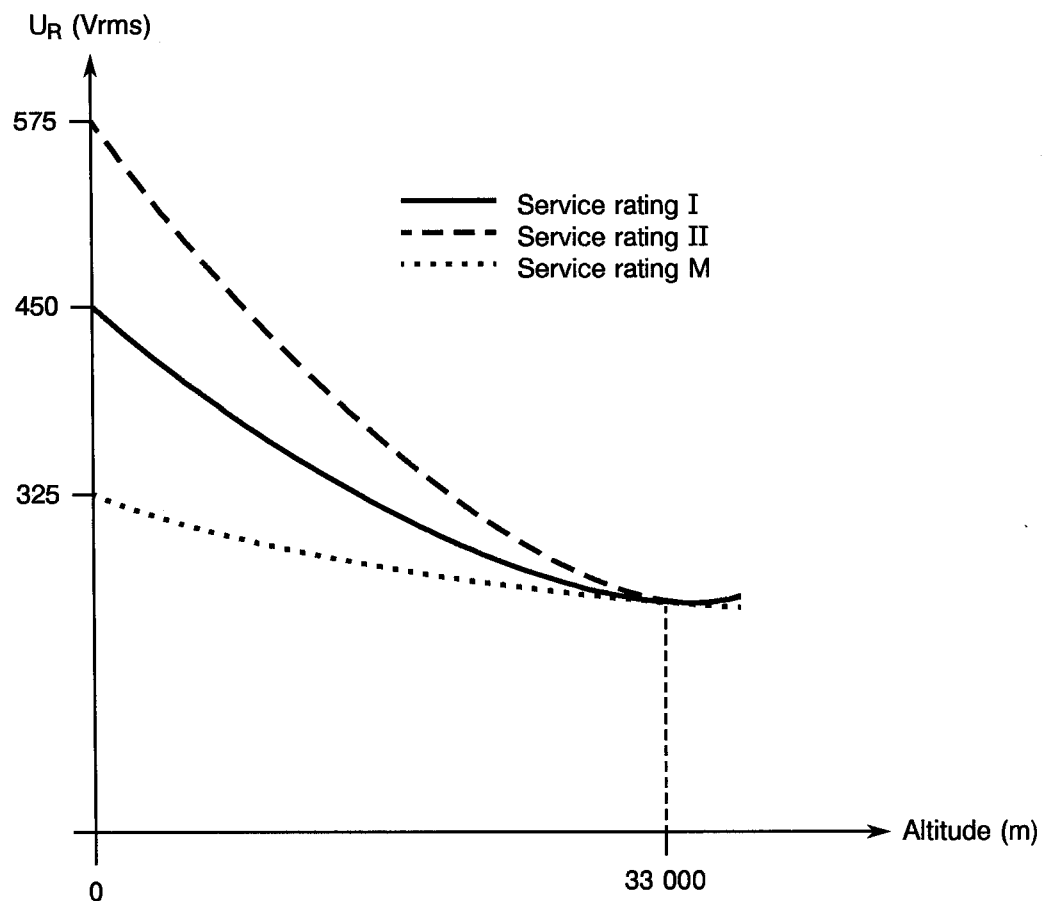
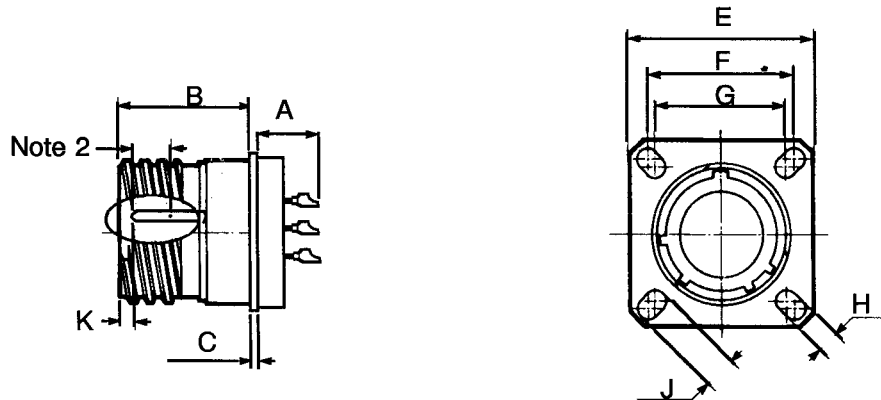

FIGURE 2 - PHYSICAL DIMENSIONS

FIGURE 2(a) - RECEPTACLES

Shell type 00H: Square flange receptacle



SHELL SIZE	09		11		13		15		17		19		21		23		25	
	MIN	MAX	MIN	MAX	MIN	MAX	MIN	MAX	MIN	MAX	MIN	MAX	MIN	MAX	MIN	MAX	MIN	MAX
A	-	5.70	-	5.70	-	5.70	-	5.70	-	5.70	-	5.70	-	5.70	-	5.70	-	5.70
B	-	21.40	-	21.40	-	21.40	-	21.40	-	21.40	-	21.40	-	21.40	-	21.40	-	21.40
C	1.90	2.60	1.90	2.60	1.90	2.60	1.90	2.60	1.90	2.60	1.90	2.60	1.90	2.60	1.90	2.60	1.90	2.60
E	23.50	24.10	25.90	26.50	28.30	28.90	30.70	31.30	33.00	33.60	36.20	36.80	39.40	40.00	42.60	43.20	45.70	46.30
F	18.16	18.36	20.52	20.72	22.91	23.11	24.51	24.71	26.87	27.07	29.26	29.46	31.65	31.85	34.83	35.03	38.00	38.20
G	14.99	15.19	18.16	18.36	20.52	20.72	22.91	23.11	24.51	24.71	26.87	27.07	29.26	29.46	31.65	31.85	34.83	35.03
H	3.05	3.45	3.05	3.45	3.05	3.45	3.05	3.45	3.05	3.45	3.05	3.45	3.05	3.45	3.71	4.11	3.71	4.11
J	5.29	5.69	4.73	5.13	4.73	5.13	4.73	5.13	4.73	5.13	4.73	5.13	4.73	5.13	5.95	6.35	5.95	6.35
K	9.50	10.54	9.50	10.54	9.50	10.54	9.50	10.54	9.50	10.54	9.50	10.54	9.50	10.54	9.50	10.54	9.50	10.54

- NOTES**
1. All dimensions are in millimetres.
 2. Measurement point for plating thickness: 4.0 ± 1.0 .

Shell type 01H: Soldermount receptacle

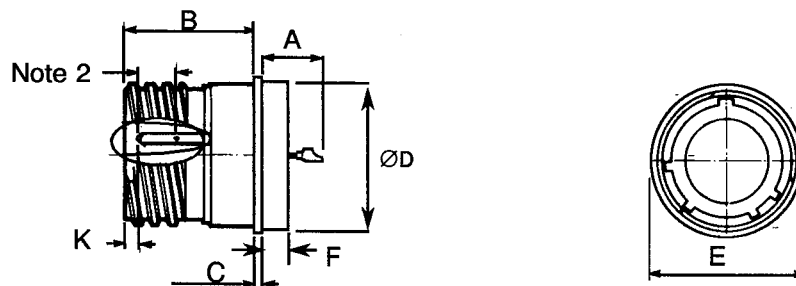

SHELL SIZE	09		11		13		15		17		19		21		23		25	
	MIN	MAX	MIN	MAX	MIN	MAX	MIN	MAX	MIN	MAX	MIN	MAX	MIN	MAX	MIN	MAX	MIN	MAX
A	-	9.70	-	9.70	-	9.70	-	9.70	-	9.70	-	9.70	-	9.70	-	9.70	-	9.70
B	-	17.80	-	17.80	-	17.80	-	17.80	-	17.80	-	17.80	-	17.80	-	17.80	-	17.80
C	0.60	1.20	0.60	1.20	0.60	1.20	0.60	1.20	0.60	1.20	0.60	1.20	0.60	1.20	0.60	1.20	0.60	1.20
ØD	-	17.10	-	19.90	-	23.10	-	26.20	-	29.40	-	31.80	-	35.00	-	38.20	-	41.30
E	-	19.40	-	21.80	-	24.90	-	28.10	-	31.30	-	33.60	-	36.80	-	40.00	-	43.20
F	-	5.10	-	5.10	-	5.10	-	5.10	-	5.10	-	5.10	-	5.10	-	5.90	-	5.90
K	9.50	10.54	9.50	10.54	9.50	10.54	9.50	10.54	9.50	10.54	9.50	10.54	9.50	10.54	9.50	10.54	9.50	10.54

- NOTES**
1. All dimensions are in millimetres.
 2. Measurement point for plating thickness: 4.0 ± 1.0 .

FIGURE 2 - PHYSICAL DIMENSIONS (CONTINUED)

FIGURE 2(a) - RECEPTACLES

Shell type 07H: Single hole mounting receptacle

L: Max. Panel Thickness

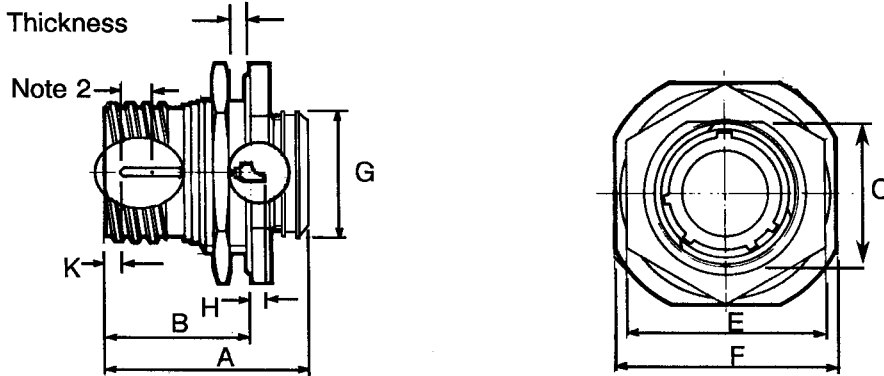

SHELL SIZE	09		11		13		15		17		19		21		23		25	
	MIN	MAX	MIN	MAX	MIN	MAX	MIN	MAX	MIN	MAX	MIN	MAX	MIN	MAX	MIN	MAX	MIN	MAX
A	-	29.20	-	29.20	-	29.30	-	29.30	-	29.30	-	30.10	-	30.10	-	30.10	-	30.10
B	-	22.60	-	22.60	-	22.60	-	22.60	-	22.60	-	22.60	-	22.60	-	22.60	-	22.60
C	16.38	16.63	18.92	19.17	23.67	23.92	26.82	27.07	30.00	30.25	33.17	33.42	36.35	36.60	39.52	39.77	42.70	42.95
E	-	24.00	-	27.00	-	32.00	-	36.00	-	37.00	-	41.00	-	46.00	-	50.00	-	51.23
F	26.60	27.40	31.40	32.20	34.50	35.30	37.70	38.50	40.90	41.70	45.60	46.40	48.80	49.60	52.00	52.80	55.20	56.00
G	16.10	16.30	19.10	19.40	22.40	22.70	25.60	25.90	28.70	29.00	31.90	32.20	35.10	35.40	38.30	38.60	41.40	41.70
H	-	5.30	-	5.30	-	5.10	-	5.10	-	5.10	-	5.10	-	5.10	-	5.90	-	5.90
K	9.50	10.54	9.50	10.54	9.50	10.54	9.50	10.54	9.50	10.54	9.50	10.54	9.50	10.54	9.50	10.54	9.50	10.54
L	1.60	3.20	1.60	3.20	1.60	3.20	1.60	3.20	1.60	3.20	1.60	3.20	1.60	3.20	1.60	3.20	1.60	3.20

NOTES

1. All dimensions are in millimetres.
2. Measurement point for plating thickness: 4.0 ± 1.0 .

FIGURE 2 - PHYSICAL DIMENSIONS (CONTINUED)

FIGURE 2(a) - RECEPTACLES

Shell Type 77H: Feedthrough receptacle

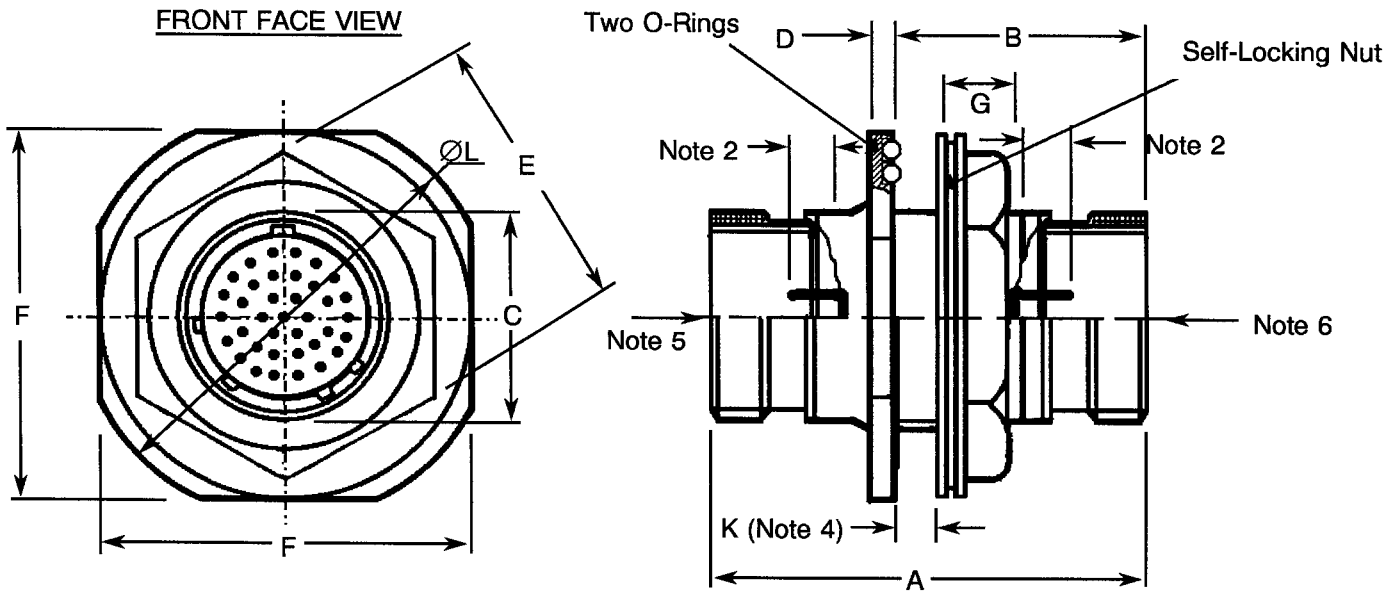

SHELL SIZE	09		11		13		15		17		19		21		23		25	
	MIN	MAX	MIN	MAX	MIN	MAX	MIN	MAX	MIN	MAX	MIN	MAX	MIN	MAX	MIN	MAX	MIN	MAX
A	-	52.80	-	52.80	-	52.80	-	52.80	-	52.80	-	52.80	-	52.80	-	52.80	-	52.80
B	-	31.40	-	31.40	-	32.00	-	32.00	-	32.00	-	32.00	-	32.00	-	32.00	-	32.00
C	16.38	16.63	18.92	19.17	23.67	23.92	26.82	27.07	30.00	30.25	33.17	33.42	36.35	36.60	38.52	38.77	42.70	42.95
D	2.50	2.90	2.50	2.90	2.50	2.90	2.50	2.90	2.50	2.90	3.30	3.70	3.30	3.70	3.30	3.70	3.30	3.70
E	22.27	22.50	24.88	25.83	29.77	30.60	32.92	33.76	36.12	37.06	39.27	40.11	42.47	43.31	45.62	46.46	50.56	51.23
F	33.00	33.59	37.85	38.38	41.02	41.55	44.20	44.79	47.37	47.90	50.55	51.09	53.72	54.25	56.90	57.43	60.07	60.50
G	9.90	10.20	9.90	10.20	9.90	10.20	9.90	10.20	9.90	10.20	9.90	10.20	9.90	10.20	9.90	10.20	9.90	10.20
K	1.57	6.35	1.57	6.35	1.57	6.35	1.57	6.35	1.57	6.35	1.57	6.35	1.57	6.35	1.57	6.35	1.57	6.35
ØL	-	36.88	-	41.58	-	44.75	-	47.93	-	51.10	-	54.28	-	57.48	-	60.63	-	63.80

NOTES

1. All dimensions are in millimetres.
2. Measurement point for plating thickness: 4.0 ± 1.0 .
3. All other dimensions are in accordance with MIL-C-38999 Series III.
4. Panel Thickness.
5. Plug 66 of ESCC No. 3401/056.
6. Plug 06 of ESCC No. 3401/056.

FIGURE 2 - PHYSICAL DIMENSIONS (CONTINUED)

FIGURE 2(b) - HIGH DENSITY CONTACT ARRANGEMENTS - FRONT VIEW MALE INSERT (3)

09-35



6 # 22D

11-35



13 # 22D

13-35



22 # 22D

15-35

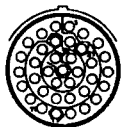

37 # 22D

17-35

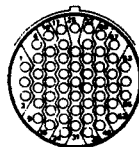

55 # 22D

19-35

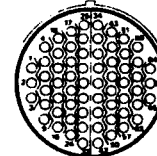

66 # 22D

21-35

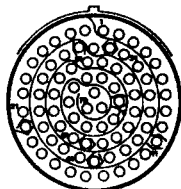

79 # 22D

23-35

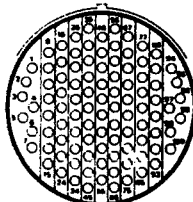

100 # 22D

25-35

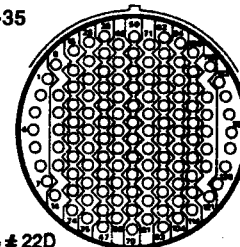

128 # 22D

NOTES

1. Contact locations and identifications in conformity with MIL-STD-1560.
2. Both sides of the inserts shall be marked.
3. For feedthrough receptacles, the view is from the mounting-nut side.

FIGURE 2 - PHYSICAL DIMENSIONS (CONTINUED)

FIGURE 2(b) - STANDARD CONTACT ARRANGEMENTS - FRONT VIEW MALE INSERT (3)

09-98

3 # 20



11-98

6 # 20



13-98

10 # 20



15-19

19 # 20

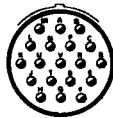

17-26

26 # 20

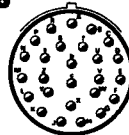

19-32

32 # 20

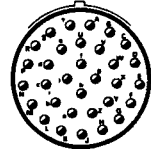

21-41

41 # 20

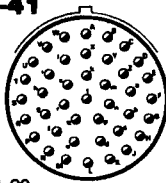

23-53

53 # 20

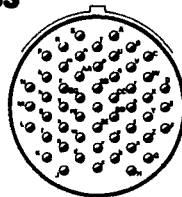

25-61

61 # 20

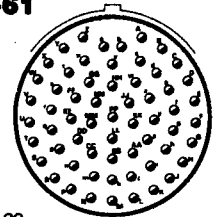

NOTES

1. Contact locations and identifications in conformity with MIL-STD-1560.
2. Both sides of the inserts shall be marked.
3. For feedthrough receptacle, the view is from the mounting-nut side.

FIGURE 2(b) - SPECIAL CONTACT ARRANGEMENTS - FRONT VIEW MALE INSERT (3)

17-08

8 # 16



19-11

11 # 16

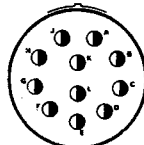

25-07

7 # 8

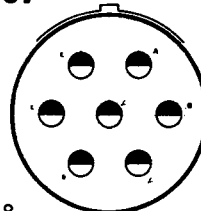

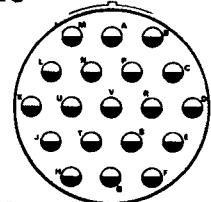

25-19

19 # 12



 size 16 contacts

 size 12 contacts

 size 8 contacts

NOTES

1. Contact locations and identifications in conformity with MIL-STD-1560, except for arrangement 25-07 which is in accordance with MIL-STD-1651.
2. Both sides of the inserts shall be marked.
3. For feedthrough receptables, the view is from the mounting-nut side.

FIGURE 2 - PHYSICAL DIMENSIONS (CONTINUED)

FIGURE 2(c) - CLOCKING POSITIONS

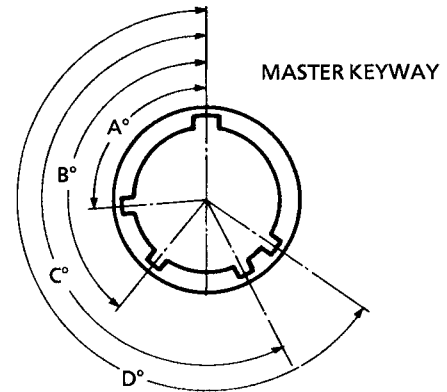

NOTES

1. The clocking position is determined by the different angles of the secondary keyways, the insert being always in the same position with respect to the master keyway position which is fixed.

Receptacle front end view

SHELL SIZE	ANGLES	CLOCKING POSITIONS					
		N	A	B	C	D	E
09	A°	105	102	80	35	64	91
	B°	140	132	118	140	155	131
	C°	215	248	230	205	234	197
	D°	265	320	312	275	304	240
11	A°	95	113	90	53	119	51
	B°	141	156	145	156	146	141
	C°	208	182	195	220	176	184
	D°	236	292	252	255	298	242
13	A°	95	113	90	53	119	51
	B°	141	156	145	156	146	141
	C°	208	182	195	220	176	184
	D°	236	292	252	255	298	242
15	A°	95	113	90	53	119	51
	B°	141	156	145	156	146	141
	C°	208	182	195	220	176	184
	D°	236	292	252	255	298	242
17	A°	80	135	49	66	62	79
	B°	142	170	169	140	145	153
	C°	196	200	200	200	180	197
	D°	293	310	244	257	280	272
19	A°	80	135	49	66	62	79
	B°	142	170	169	140	145	153
	C°	196	200	200	200	180	197
	D°	293	310	244	257	280	272
21	A°	80	135	49	66	62	79
	B°	142	170	169	140	145	153
	C°	196	200	200	200	180	197
	D°	293	310	244	257	280	272
23	A°	80	135	49	66	62	79
	B°	142	170	169	140	145	153
	C°	196	200	200	200	180	197
	D°	293	310	244	257	280	272
25	A°	80	135	49	66	62	79
	B°	142	170	169	140	145	153
	C°	196	200	200	200	180	197
	D°	293	310	244	257	280	272

4. REQUIREMENTS

4.1 GENERAL

The complete requirements for procurement of the connectors specified herein are stated in this specification and ESCC Generic Specification No. 3401. Deviations from the Generic Specification applicable to this specification only, are listed in Para 4.2.

Deviations from the applicable Generic Specification and this Detail Specification, formally agreed with specific Manufacturers on the basis that the alternative requirements are equivalent to the ESCC requirements and do not affect the components' reliability, are listed in the Appendices attached to this specification.

4.2 DEVIATIONS FROM GENERIC SPECIFICATION

4.2.1 Deviations from Special In-process Controls

For the qualification and LAT1 lots, Para. 5.2.4, Plating Thickness, is not applicable.

4.2.2 Deviations from Final Production Tests (Chart II(b))

- (a) Para. 9.2, Mating Verification: Shall be performed with 3401/056 plugs.
- (b) Para. 9.3, Contact Retainer test: Not applicable.
- (c) Para. 9.4, Contact Capability: Not applicable.
- (d) Para. 9.5, Residual Magnetism: Not applicable.

4.2.3 Deviations from Burn-in and Electrical Measurements (Chart III)

Not applicable.

4.2.4 Deviations from Qualification Tests (Chart IV)

- (a) Para. 9.11.2, Sinusoidal Vibration Testing
 - 10-55Hz at 8.25mm double amplitude displacement.
 - 56-2000Hz at 50g.
 - 1 cycle (10-2000-10 Hz) per axis at a sweep rate of 1 octave per minute.
- (b) Para. 9.11.3, Random Vibration Testing
 - 20-100Hz at +6dB per octave.
 - 100-2000Hz, constant at 1.0g²/Hz.
 - 3 axes.
 - 7 minutes per axis.
- (c) Para 9.12.1, Shock: 75g, 11 milliseconds, half sine wave.
- (d) Para. 9.15, Joint Strength: Not applicable to feedthrough receptacles Type 77.
- (e) Para. 9.24, Jackscrew Retention: Not applicable.
- (f) Para. 9.27, Maintenance Ageing: Not applicable.
- (g) Para. 9.28, Engagement and Separation Forces: Not applicable.
- (h) Para. 9.29, Oversize Pin Exclusion: Not applicable.
- (i) Para. 9.30, Probe Damage: Not applicable.



4.2.5 Deviations from Lot Acceptance Tests (Chart V)

- (a) Para. 9.28, Engagement and Separation Forces: Not applicable.
- (b) Para. 9.29, Oversize Pin Exclusion: Not applicable.
- (c) Para. 9.30, Probe Damage: Not applicable.

4.3 MECHANICAL REQUIREMENTS

4.3.1 Dimension Check

The dimensions of the connectors specified herein shall be verified in accordance with the requirements set out in Para 9.6 of ESCC Generic Specification No. 3401 and shall conform to those shown in Figure 2 of this specification.

4.3.2 Weight

The maximum weight of the connectors specified herein shall be as specified in Table 1(a).

4.3.3 Contact Capability

Not applicable.

4.3.4 Contact Retention (In Insert)

The minimum contact retention force shall be 44 Newtons for size 22D contacts, 67 Newtons for size 20 contacts and 100 Newtons for size 16, 12 and 8 contacts.

4.3.5 Mating and Unmating Forces

The forces applied for mating and unmating of the connectors (axial and torque) shall conform to the values specified in Table 1(a) of ESCC Detail Specification No. 3401/056.

4.3.6 Insert Retention (In Shell)

Connector inserts shall withstand a pressure of 70N/cm² without being dislodged from the shell.

4.3.7 Jackscrew Retention

Not applicable.

4.3.8 Contact Insertion and Withdrawal Forces

Not applicable.

4.3.9 Engagement and Separation Forces

Not applicable.

4.3.10 Oversize Pin Exclusion

Not applicable.

4.3.11 Probe Damage

Not applicable.

4.3.12 Solderability

Size A soldering iron shall be used. Not applicable to feedthrough receptacle Type 77.



4.4 MATERIALS AND FINISHES

The materials and finishes shall be as specified herein. Where a definite material is not specified, a material which will enable the connectors specified herein to meet the performance requirements of this specification shall be used. Acceptance or approval of any constituent material does not guarantee acceptance of the finished product.

4.4.1 Shell and Nuts

Shells and mounting nut shall be made of dull, low reflective, passivated stainless steel.

4.4.2 Insert

The insert shall be made of sintered glass. The interface inserts shall be made of silicone rubber.

4.4.3 Contacts

The contacts shall be made of nickel-iron with nickel underplate and gold finish (minimum thickness: 1.27µm).

4.4.4 Contact Retaining Clip

Not applicable.

4.4.5 Guiding and Locking Devices

Not applicable.

4.4.6 Magnetism Level

Not applicable.

4.5 MARKING

4.5.1 General

The marking of all components delivered to this specification shall be in accordance with the requirements of ESCC Basic Specification No. 21700 and the following subparagraphs. Each component shall be marked in respect of:-

- (a) Contact Identification.
- (b) The ESCC Component Number.
- (c) Characteristics.
- (d) Traceability information.

4.5.2 Contact Identification

Contact identification shall be marked in accordance with Figure 2(b).

4.5.3 The ESCC Component Number

The ESCC component number shall be constituted and marked as follows:

Detail Specification Number _____ 340105701B
Type Variant (Note 1) _____
Testing Level _____

NOTES 1. Marking of the Type Variant Number is mandatory. No further reference to type variant is made in this specification.

4.5.4 Characteristics

The characteristics to be marked in the following order of precedence are:

- (a) Shell type.
- (b) Hermetic version.
- (c) Contact arrangement.
- (d) Type of contact.
- (e) Clocking position.

The information shall be constituted and marked as follows:-

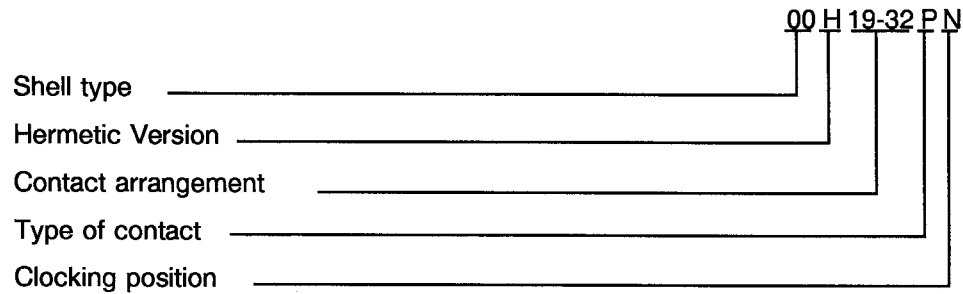

4.5.4.1 Shell Type

The shell type shall be indicated by the numbers specified hereafter:

CODE NO	SHELL TYPE
00	Square flange receptacle
01	Solder mount receptacle
07	Single hole mounting receptacle
77	Feedthrough receptacle

4.5.4.2 Hermetic Version

The hermetic version shall be indicated by the letter "H".

4.5.4.3 Contact Arrangements

The number of contacts shall be as shown in Figure 2(b) and contact arrangements shall be indicated by the codes specified hereafter:

CODE	SERVICE RATING
09-35	M
09-98	I
11-35	M
11-98	I
13-35	M
13-98	I
15-35	M
15-19	I
17-08	II
17-35	M
17-26	I
19-11	II
19-35	M
19-32	I
21-35	M
21-41	I
23-35	M
23-53	I
25-07	I
25-19	I
25-35	M
25-61	I

4.5.4.4 Type of Contact

The contact type shall be indicated by the following code letter:-

CODE LETTER	CONTACT TYPE
P	Male

4.5.4.5 Clocking Position

Clocking positions are as shown in Figure 2(c) and shall be designated by the following code letters: A, B, C, D and E. Code letter N indicates the standard clocking position. For feedthrough receptacle Type 77, the clocking position shall be identical on both sides.

4.5.5 Traceability Information

Traceability information shall be marked in accordance with the requirements of ESCC Basic Specification No. 21700.

4.5.6 Marking of Small Components

Where it is considered that a component is too small to accommodate the marking as specified above, as much as space permits shall be marked. The order of precedence shall be as specified in Para. 4.5.1. The marking information in full shall accompany each component in its primary package.

4.6 ELECTRICAL MEASUREMENTS

4.6.1 Electrical Measurements at Room Temperature

The parameters to be measured in respect of electrical characteristics are scheduled in Table 2. Unless otherwise specified these measurements shall be performed at $T_{amb} = +22 \pm 3 \text{ }^{\circ}\text{C}$.

4.6.2 Electrical Measurements at High and Low Temperatures (Table 3)

Not applicable.

4.6.3 Circuit for Electrical Measurements (Figure 4)

Not applicable.

4.7 BURN-IN AND ELECTRICAL MEASUREMENTS (TABLES 4 AND 5)

Not applicable.

4.8 ENVIRONMENTAL AND ENDURANCE TESTS (CHARTS IV AND V OF ESCC GENERIC SPECIFICATION No. 3401)

4.8.1 Measurements and Inspections on Completion of Environmental Tests

The parameters to be measured and inspections to be performed on completion of environmental testing shall be those specified in Table 6.

Unless otherwise specified, these measurements shall be performed at $T_{amb} = +22 \pm 3 \text{ }^{\circ}\text{C}$.

4.8.2 Measurements and Inspections at Intermediate Points during Endurance Tests.

Not applicable.

4.8.3 Measurements and Inspections on Completion of Endurance Tests

The parameters to be measured and inspections to be performed on completion of endurance tests shall be those specified in Table 6. Unless otherwise specified, these measurements shall be performed at $T_{amb} = +22 \pm 3 \text{ }^{\circ}\text{C}$.

4.8.4 Conditions for Operating Life Test (Part of Endurance Testing)

Not applicable.

4.8.5 Electrical Circuits for Operating Life Test

Not applicable.

4.8.6 Conditions for High Temperature Storage Test (Part of Endurance Testing)

The requirements for the high temperature storage test are specified in Section 9 of ESCC Generic Specification No. 3401. The conditions for high temperature storage testing shall be the maximum temperature specified in Table 1(b) of this specification.



TABLE 2 - ELECTRICAL MEASUREMENTS AT ROOM TEMPERATURE

NO	CHARACTERISTICS	SYMBOL	SPEC. AND/OR TEST METHOD	TEST CONDITION	LIMITS		UNIT
					MIN	MAX	
1	Insulation Resistance	R _i	ESCC No. 3401 Para 9.1.1.1	Para 9.1.1.1	5 000	-	MΩ
2	Voltage Proof Leakage Current Service II Service I Service M	I _L	ESCC No. 3401 Para 9.1.1.2	2 300Vrms 1 800Vrms 1 300Vrms	-	2.0	mA
3	Mated Shell Conductivity (Voltage Drop)	V _d	ESCC 3401 Para. 9.1.1.4	Para. 9.1.1.4 (Note 1)	Not applicable		mV
4	Contact Resistance (Low Level Current)	R _{cl}	ESCC No. 3401 Para 9.1.1.3	Para 9.1.1.3 Size 22D Size 20 Size 16 Size 12 Size 8	-	(Note 2) 50 25 12 6.0 2.5	mΩ
5	Contact Resistance (Rated Current)	R _{cr}	ESCC No. 3401 Para 9.1.1.3	Para 9.1.1.3 Size 22D 3.0A Size 20 5.0A Size 16 10A Size 12 17A Size 8 33A	-	(Note 2) 60 30 15 8.0 3.0	mΩ

NOTES

1. Applicable to mated connectors with grounding option.
2. With 1 plug on each side of the feedthrough, double the maximum limit.

TABLES 3, 4 AND 5

Not applicable.



TABLE 6 - MEASUREMENTS AND INSPECTIONS ON COMPLETION OF ENVIRONMENTAL AND ENDURANCE TESTS

NO.	ESCC GENERIC NO. 3401		MEASUREMENTS AND INSPECTIONS		SYMBOL	LIMITS		UNIT
	ENVIRONMENTAL AND ENDURANCE TESTS (1)	TEST METHOD AND CONDITIONS	IDENTIFICATION	CONDITIONS		MIN	MAX	
01	Wiring	Para. 9.10 & Table 1(a) of this spec.	Low Level Contact Resistance	Table 2 Item 1	Rcl	Table 2 Item 1		
02	Vibration	Para. 9.11 and Para. 4.2.4 of this spec	Initial Measurements Coupling Screw(s) Unlocking Torque Final Measurements Full Engagement Coupling Screw(s) Unlocking Torque Drift Visual Examination	- - - -	- Δ -	Not applicable Not applicable		%
03	Shock or Bump	Para. 9.12 and Para. 4.2.4 of this spec	Full Engagement Visual Examination	- -	- -	- -	- -	
04	Climatic Sequence	Para. 9.13	Dry Heat Insulation Resistance Low Air Pressure Volt. Proof Leakage Current Damp Heat Insulation Resistance External Visual Inspection Insulation Resistance Voltage Proof leakage Curr.	Table 2 Item 1 250 Vrms Immediately after test Table 2 Item 1 After 1-24 hrs Recovery ESCC 3401 Para. 9.7 Table 2 Item 1 Table 2 Item 2	Ri I _L Ri - Ri I _L	1 000 Table 2 Item 2 100 ESCC 3401 Para. 9.7 Table 2 Item 1 Table 2 Item 2	- - - -	M Ω M Ω
05	Seal Test	Para. 9.9	ESCC 3401 Para. 9.9			ESCC 3401 Para. 9.9		
06	Plating Thickness	Para. 9.14	Thickness	-		Para. 4.4.3 of this spec.		
07	Joint Strength	Para. 9.15	ESCC 3401 Para 9.15			ESCC 3401 Para. 9.15		
08	Rapid Change of Temperature	Para. 9.16	Visual Examination Insulation Resistance Voltage Proof Leakage Curr.	- Table 2 Item 1 Table 2 Item 2	- Ri I _L	- Table 2 Item 1 Table 2 Item 2	- -	
09	Contact Retention (in insert)	Para. 9.17 & Para. 4.3.4 of this spec.	Contact Retention	-	-	Para. 4.3.4		

NOTES 1. The tests in this table refer to either Chart IV or V and shall be used as applicable.



TABLE 6 - MEASUREMENTS AND INSPECTIONS ON COMPLETION OF ENVIRONMENTAL AND ENDURANCE TESTS (CONTINUED)

NO.	ESCC GENERIC NO. 3401.		MEASUREMENTS AND INSPECTIONS		SYMBOL	LIMITS		UNIT
	ENVIRONMENTAL AND ENDURANCE TESTS (1)	TEST METHOD AND CONDITIONS	IDENTIFICATION	CONDITIONS		MIN	MAX	
10	Endurance	Para. 9.18	Initial Measurements Mating/Unmating Forces Low Level Contact Resist Mated Shell Conductivity Final Measurements Visual Examination Mating/Unmating Forces Low Level Contact Resistance Drift Mated Shell Conductivity Insulation Resistance Voltage Proof Leakage Curr.	Table 2 Item 4 Table 2 Item 3 - Table 2 Item 4 Table 2 Item 3 Table 2 Item 1 Table 2 Item 2	F Rcl Vd - F ΔRcl Vd Ri I _L	Para. 4.3.5 of this spec Record Values Not applicable - - Para. 4.3.5 of this spec - 3.0 Not applicable Table 2 Item 1 Table 2 Item 2	mΩ	
11	Permanence of Marking	Para. 9.19	As applicable		-	-	-	
12	Mating/Unmating Forces	Para. 9.20	Force		F	Para. 4.3.5 of this spec		
13	High Temperature Storage	Para. 9.21	Initial Measurements Low Level Contact Resis. Mated Shell Conductivity Final Measurements Visual Examination Mating/Unmating Forces Low Level Contact Resistance Drift Rated Current Contact Resis. Mated Shell Conductivity Insulation Resistance Voltage Proof Leakage Curr. Contact Retention (in insert)	Table 2 Item 4 Table 2 Item 3 - Table 2 Item 4 Table 2 Item 5 Table 2 Item 3 Table 2 Item 1 Table 2 Item 2 Para. 4.3.4 of this spec.	Rcl Vd - F ΔRcl Rcr Vd Ri I _L	Record Values Not applicable - - Para. 4.3.5 of this spec - 3.0 Table 2 Item 5 Not applicable Table 2 Item 1 Table 2 Item 2 Para. 4.3.4	mΩ	
14	Corrosion	Para. 9.22	Visual Examination	-	-	-	-	
15	Insert Retention (in shell)	Para. 9.23 & Para. 4.3.6 of this spec.	Visual Examination	-	-	Para. 4.3.6		
16	Jackscrew Retention	Para. 9.24 & Para. 4.3.7 of this spec.	Force	-	-	Not applicable		
17	High Temperature Measurements	Para. 9.25	Insulation Resistance	Table 2 Item 1	Ri	500	-	MΩ

NOTES

1. The tests in this table refer to either Chart IV or V and shall be used as applicable.

TABLE 6 - MEASUREMENTS AND INSPECTIONS ON COMPLETION OF ENVIRONMENTAL AND ENDURANCE TESTS (CONTINUED)

NO.	ESCC GENERIC NO. 3401		MEASUREMENTS AND INSPECTIONS		SYMBOL	LIMITS		UNIT
	ENVIRONMENTAL AND ENDURANCE TESTS (1)	TEST METHOD AND CONDITIONS	IDENTIFICATION	CONDITIONS		MIN	MAX	
18	Overload Test	Para. 9.26	Internal Temperature Rated Current Contact Resis. Mated Shell Conductivity Insulation Resistance Voltage Proof Leakage Curr.	Table 2 Item 5 Table 2 Item 3 Table 2 Item 1 Table 2 Item 2	T Rcr Vd Ri I _L	-	+100	°C
19	Maintenance Aging	Para. 9.27	Visual Examination Contact Retention Contact Insertion & Withdrawal Forces	- Para. 4.3.4 of this spec. Para. 4.3.8 of this spec.	-	-	-	Not applicable Not applicable
20	Engage/Separation Forces	Para. 9.28 & Para. 4.3.9 of this spec.	Force	-		Not applicable		
21	Oversize Pin Exclusion	Para. 9.29 & Para. 4.3.10 of this spec.	-	-		Not applicable		
22	Probe Damage	Para. 9.30 & Para. 4.3.11 of this spec.	Contact Separation Force	Para. 4.3.9 of this spec		Not applicable		
23	Solderability	Para. 9.31 & Para. 4.3.12 of this spec.	-	-	-	ESCC 3401 Para. 9.31		

NOTES

1. The tests in this table refer to either Chart IV or V and shall be used as applicable.