



Pages 1 to 14

## **TRANSISTORS, FIELD-EFFECT, N-CHANNEL**

**BASED ON TYPE 2N4391, 2N4392 AND 2N4393**

**ESCC Detail Specification No. 5205/003**

Issue 3	January 2010
---------	--------------



Document Custodian: European Space Agency - see <https://escies.org>

**LEGAL DISCLAIMER AND COPYRIGHT**

European Space Agency, Copyright © 2010. All rights reserved.

The European Space Agency disclaims any liability or responsibility, to any person or entity, with respect to any loss or damage caused, or alleged to be caused, directly or indirectly by the use and application of this ESCC publication.

This publication, without the prior permission of the European Space Agency and provided that it is not used for a commercial purpose, may be:

- copied in whole, in any medium, without alteration or modification.
- copied in part, in any medium, provided that the ESCC document identification, comprising the ESCC symbol, document number and document issue, is removed.

**DOCUMENTATION CHANGE NOTICE**

(Refer to <https://escies.org> for ESCC DCR content)

DCR No.	CHANGE DESCRIPTION
509	Specification up issued to incorporate editorial and technical changes per DCR.

**TABLE OF CONTENTS**

<b><u>1.</u></b>	<b><u>GENERAL</u></b>	<b><u>5</u></b>
1.1	Scope	5
1.2	Applicable Documents	5
1.3	Terms, Definitions, Abbreviations, Symbols and Units	5
1.4	The ESCC Component Number and Component Type Variants	5
1.4.1	The ESCC Component Number	5
1.4.2	Component Type Variants	5
1.5	Maximum Ratings	5
1.6	Physical Dimensions and Terminal Identification	6
1.6.1	Metal Can Package (TO-18) - 3 lead	6
1.7	Functional Diagram	7
1.8	Materials and Finishes	8
<b><u>2.</u></b>	<b><u>REQUIREMENTS</u></b>	<b><u>8</u></b>
2.1	General	8
2.1.1	Deviations from the Generic Specification	8
2.2	Marking	8
2.3	Terminal Strength	8
2.4	Electrical Measurements at Room, High and Low Temperatures	9
2.4.1	Room Temperature Electrical Measurements	9
2.4.2	High and Low Temperatures Electrical Measurements	12
2.5	Parameter Drift Values	13
2.6	Intermediate and End-Point Electrical Measurements	13
2.7	High Temperature Reverse Bias Burn-in Conditions	14
2.8	Operating Life Conditions	14

## 1. GENERAL

### 1.1 SCOPE

This specification details the ratings, physical and electrical characteristics and test and inspection data for the component type variants and/or the range of components specified below. It supplements the requirements of, and shall be read in conjunction with, the ESCC Generic Specification listed under Applicable Documents.

### 1.2 APPLICABLE DOCUMENTS

The following documents form part of this specification and shall be read in conjunction with it:

- (a) ESCC Generic Specification No. 5000
- (b) MIL-STD-750, Test Methods and Procedures for Semiconductor Devices

### 1.3 TERMS, DEFINITIONS, ABBREVIATIONS, SYMBOLS AND UNITS

For the purpose of this specification, the terms, definitions, abbreviations, symbols and units specified in ESCC Basic Specification No. 21300 shall apply.

### 1.4 THE ESCC COMPONENT NUMBER AND COMPONENT TYPE VARIANTS

#### 1.4.1 The ESCC Component Number

The ESCC Component Number shall be constituted as follows:

Example: 520500301

- Detail Specification Reference: 5205003
- Component Type Variant Number: 01 (as required)

#### 1.4.2 Component Type Variants

The component type variants applicable to this specification are as follows:

Variant Number	Based on Type	Case	Lead/Terminal Material and Finish	Weight max g
01	2N4391	TO-18	D2	0.9
02	2N4392	TO-18	D2	0.9
03	2N4393	TO-18	D2	0.9

The lead/terminal material and finish shall be in accordance with the requirements of ESCC Basic Specification No. 23500.

### 1.5 MAXIMUM RATINGS

The maximum ratings shall not be exceeded at any time during use or storage.

Maximum ratings shall only be exceeded during testing to the extent specified in this specification and

when stipulated in Test Methods and Procedures of the ESCC Generic Specification.

Characteristics	Symbols	Maximum Ratings	Unit	Remarks
Drain-Source Voltage	$V_{DS}$	40	V	Over entire operating temperature range
Gate-Source Voltage	$V_{GS}$	-40	V	
Gate-Drain Voltage	$V_{GD}$	-40	V	
Gate Current	$I_G$	50	mA	
Power Dissipation	$P_{tot1}$	0.3	W	At $T_{amb} \leq +25^{\circ}C$
	$P_{tot2}$	1.8	W	At $T_{case} \leq +25^{\circ}C$
Thermal Resistance, Junction-to-Ambient	$R_{th(j-a)}$	500	$^{\circ}C/W$	
Thermal Resistance, Junction-to-Case	$R_{th(j-c)}$	83.3	$^{\circ}C/W$	
Operating Temperature Range	$T_{op}$	-55 to +175	$^{\circ}C$	Note 1
Storage Temperature Range	$T_{stg}$	-65 to +200	$^{\circ}C$	Note 1
Soldering Temperature	$T_{sol}$	+235	$^{\circ}C$	Note 2

**NOTES:**

1. For Variants with tin-lead plating or hot solder dip lead finish all testing, and any handling, performed at  $T_{amb} > +125^{\circ}C$  shall be carried out in a 100% inert atmosphere.
2. Duration 10 seconds maximum at a distance of not less than 1.5mm from the device body and the same lead shall not be resoldered until 3 minutes have elapsed.

1.6 PHYSICAL DIMENSIONS AND TERMINAL IDENTIFICATION

1.6.1 Metal Can Package (TO-18) - 3 lead

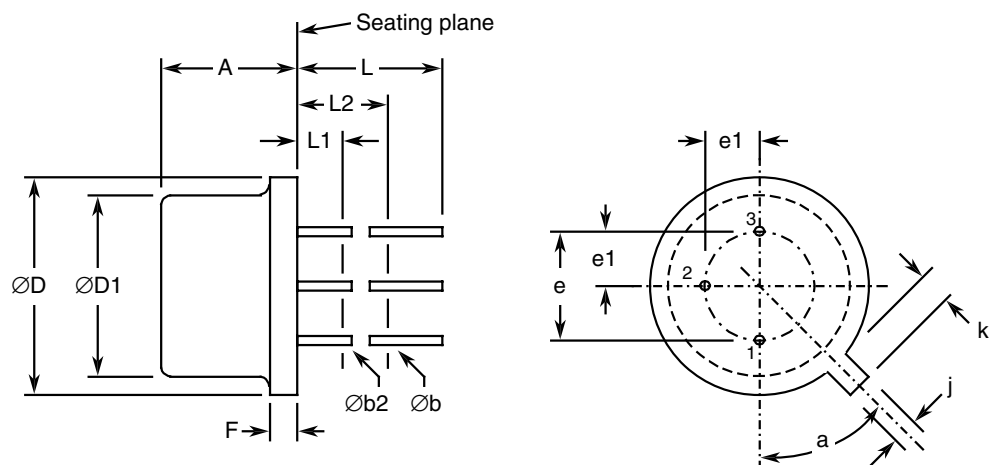

Symbols	Dimensions mm		Notes
	Min	Max	
A	4.32	5.33	
Øb	0.406	0.533	2, 3
Øb2	0.406	0.483	2, 3
ØD	5.31	5.84	
ØD1	4.52	4.95	
e	2.54 BSC		4
e1	1.27 BSC		4
F	-	0.762	
j	0.914	1.17	
k	0.711	1.22	5
L	12.7	-	2
L1	-	1.27	3
L2	6.35	-	3
a	45° BSC		1, 4, 6

**NOTES:**

1. Terminal identification is specified by reference to the tab position where lead 1 = source, lead 2 = drain, lead 3 = gate.
2. Applies to all leads.
3. Øb2 applies between L1 and L2. Øb applies between L2 and 12.7mm from the seating plane. Diameter is uncontrolled within L1 and beyond 12.7mm from the seating plane.
4. Leads having maximum diameter 0.483mm measured in the gauging plane 1.37(+0.025,-0)mm below the seating plane of the device shall be within 0.178mm of their true position relative to a maximum-width-tab.
5. Measured from the maximum diameter of the actual device.
6. Tab centreline.

1.7 FUNCTIONAL DIAGRAM

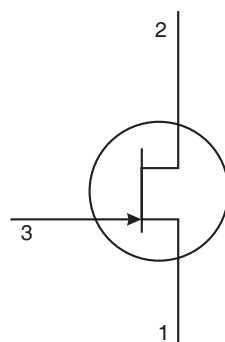

1. Source.
2. Drain.
3. Gate.

**NOTES:**

1. The gate is internally connected to the case.

**1.8 MATERIALS AND FINISHES**

Materials and finishes shall be as follows:

- a) Case  
The case shall be hermetically sealed and have a metal body with hard glass seals.
- b) Leads/Terminals  
As specified in Component Type Variants.

**2. REQUIREMENTS****2.1 GENERAL**

The complete requirements for procurement of the components specified herein are as stated in this specification and the ESCC Generic Specification. Permitted deviations from the Generic Specification, applicable to this specification only, are listed below.

Permitted deviations from the Generic Specification and this Detail Specification, formally agreed with specific Manufacturers on the basis that the alternative requirements are equivalent to the ESCC requirement and do not affect the component's reliability, are listed in the appendices attached to this specification.

**2.1.1 Deviations from the Generic Specification**

- (a) Deviation from Screening Tests - Chart F3  
Power Burn-in and the subsequent Parameter Drift Values (Final Measurements) shall be omitted.

**2.2 MARKING**

The marking shall be in accordance with the requirements of ESCC Basic Specification No. 21700 and as follows.

The information to be marked on the component shall be:

- (a) The ESCC qualified components symbol (for ESCC qualified components only).
- (b) The ESCC Component Number.
- (c) Traceability information.

**2.3 TERMINAL STRENGTH**

The test conditions for terminal strength, tested as specified in the ESCC Generic Specification, shall be as follows:

Test Condition: A, tension, with an applied force of 5N for a duration of 10s.



2.4 ELECTRICAL MEASUREMENTS AT ROOM, HIGH AND LOW TEMPERATURES

Electrical measurements shall be performed at room, high and low temperatures.

2.4.1 Room Temperature Electrical Measurements

The measurements shall be performed at  $T_{amb}=+22 \pm 3^{\circ}C$ .

Characteristics	Symbols	MIL-STD-750 Test Method	Test Conditions	Limits		Units
				Min	Max	
Gate Reverse Leakage Current	$I_{GSS}$	3411	$V_{GS}=-20V$ Bias condition C	-	-100	pA
Gate-Source Breakdown Voltage	$V_{(BR)GSS}$	3401	$I_G=1\mu A$ Bias condition C	-40	-	V
Drain Cut-off Current	$I_{DSX}$	3413	$V_{DS}=20V$ Variant 01: $V_{GS}=-12V$ Variant 02: $V_{GS}=-7V$ Variant 03: $V_{GS}=-5V$ Bias condition A	-	100	pA
Drain Current	$I_{DSS}$	3413	$V_{DS}=20V$ Bias condition C Note 1			mA
Variant 01				50	150	
Variant 02				25	75	
Variant 03				5	30	
Gate-Source Cut-off Voltage	$V_{GS(off)}$	3403	$V_{DS}=20V$ $I_D=1nA$			V
Variant 01				-4	-10	
Variant 02				-2	-5	
Variant 03				-0.5	-3	
Drain-Source Saturation Voltage	$V_{DS(sat)}$	3405	Variant 01: $I_D=12mA$ Variant 02: $I_D=6mA$ Variant 03: $I_D=3mA$ Bias condition B	-	400	mV
Static ON-State Drain-Source Resistance	$r_{DS(on)}$	3421	$I_D=1mA$ Bias condition B			$\Omega$
Variant 01				-	30	
Variant 02				-	60	
Variant 03				-	100	
Small-Signal ON-State Drain-Source Resistance	$r_{ds(on)}$	3423	$I_D=0A$ $f=1kHz$ Bias condition B Note 2			$\Omega$
Variant 01				-	30	
Variant 02				-	60	
Variant 03				-	100	

Characteristics	Symbols	MIL-STD-750 Test Method	Test Conditions	Limits		Units
				Min	Max	
Small-Signal Common-Source Short-Circuit Input Capacitance	$C_{iss}$	3431	$V_{GS}=0V$ $V_{DS}=20V$ $f=1MHz$ Note 2	-	26	pF
Small-Signal Common-Source Short-Circuit Reverse Transfer Capacitance	$C_{rss}$	3433	$V_{DS}=0V$ $f=1MHz$ Variant 01: $V_{GS}=-12V$ Variant 02: $V_{GS}=-7V$ Variant 03: $V_{GS}=-5V$ Note 2	-	4	pF
Rise Time	$t_r$	3459	$V_{DD}=10V$ $V_{GS}=0V$ Variant 01: $V_{GSX}=-12V,$ $I_{D(on)}=12mA$ Variant 02: $V_{GSX}=-7V, I_{D(on)}=6mA$ Variant 03: $V_{GSX}=-5V, I_{D(on)}=3mA$ Notes 2, 3	-	5	ns
Turn-on Delay Time	$t_{d(on)}$	3459	$V_{DD}=10V$ $V_{GS}=0V$ Variant 01: $V_{GSX}=-12V,$ $I_{D(on)}=12mA$ Variant 02: $V_{GSX}=-7V, I_{D(on)}=6mA$ Variant 03: $V_{GSX}=-5V, I_{D(on)}=3mA$ Notes 2, 3	-	15	ns
Fall Time	$t_f$	3459	$V_{DD}=10V$ $V_{GS}=0V$ Variant 01: $V_{GSX}=-12V,$ $I_{D(on)}=12mA$ Variant 02: $V_{GSX}=-7V, I_{D(on)}=6mA$ Variant 03: $V_{GSX}=-5V, I_{D(on)}=3mA$ Notes 2, 3	-	15 20 30	ns

Characteristics	Symbols	MIL-STD-750 Test Method	Test Conditions	Limits		Units
				Min	Max	
Turn-off Delay Time	$t_{d(off)}$	3459	$V_{DD}=10V$ $V_{GS}=0V$ Variant 01: $V_{GSX}=-12V,$ $I_{D(on)}=12mA$ Variant 02: $V_{GSX}=-7V, I_{D(on)}=6mA$ Variant 03: $V_{GSX}=-5V, I_{D(on)}=3mA$ Notes 2, 3	-	20	ns
				-	35	
				-	50	

**NOTES:**

1. Pulsed measurement: Pulse Width  $\leq 300\mu s$ , Duty Cycle  $\leq 2\%$ .
2. For AC characteristics read and record measurements shall be performed on a sample of 32 components with 0 failures allowed. Alternatively a 100% inspection may be performed.
3.  $t_r$ ,  $t_{d(on)}$ ,  $t_f$  and  $t_{d(off)}$  shall be measured using the following test circuit. The input waveform shall be supplied by a pulse generator with the following characteristics:  $Z_{out} = 50\Omega$ ,  $t_r = t_f \leq 500ps$ , Pulse Width =  $1\mu s$ , Duty Cycle = 10%. The output waveform shall be monitored on an oscilloscope with the following characteristics:  $Z_{in} = 50\Omega$ ,  $t_r \leq 400ps$ .

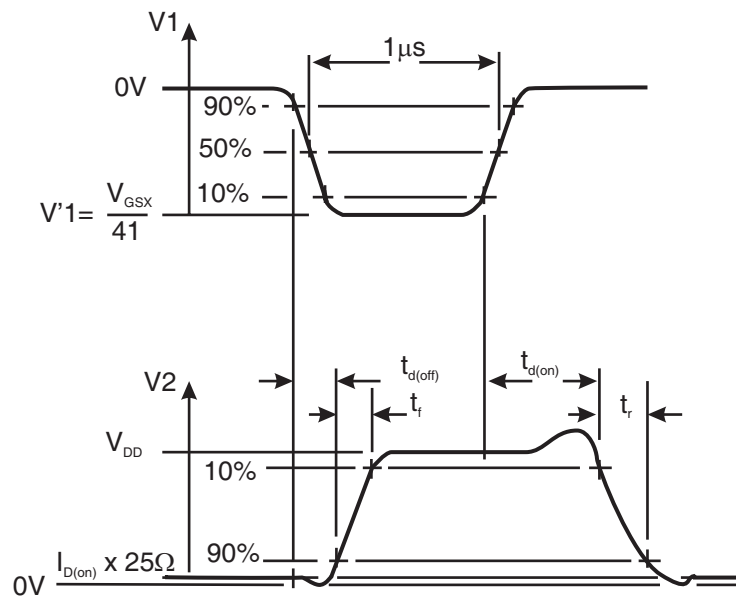
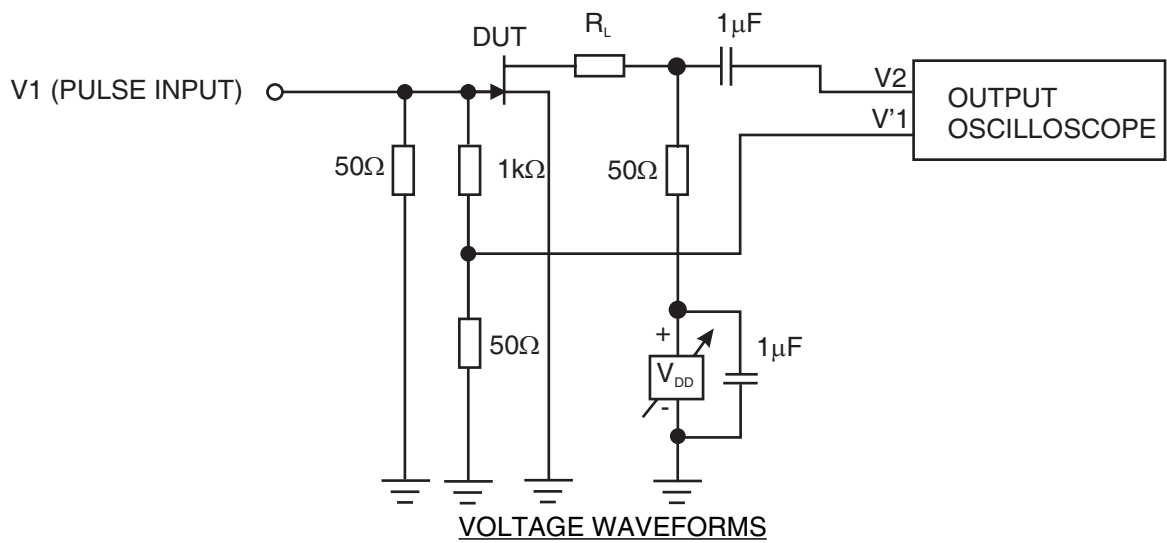

### 2.4.2 High and Low Temperatures Electrical Measurements

Characteristics	Symbols	MIL-STD-750 Test Method	Test Conditions Note 1	Limits		Units
				Min	Max	
Gate Reverse Leakage Current	$I_{GSS}$	3411	$T_{amb}=+150(+0-5)^{\circ}C$ $V_{GS}=-20V$ Bias condition C	-	-200	nA

Characteristics	Symbols	MIL-STD-750 Test Method	Test Conditions Note 1	Limits		Units
				Min	Max	
Drain Cut-off Current	$I_{DSX}$	3413	$T_{amb}=+150(+0-5)^{\circ}C$ $V_{DS}=20V$ Variant 01: $V_{GS}=-12V$ Variant 02: $V_{GS}=-7V$ Variant 03: $V_{GS}=-5V$ Bias condition A	-	200	nA

**NOTES:**

1. Read and record measurements shall be performed on a sample of 5 components with 0 failures allowed. Alternatively a 100% inspection may be performed.

2.5

PARAMETER DRIFT VALUES

Unless otherwise specified, the measurements shall be performed at  $T_{amb}=+22 \pm 3^{\circ}C$ .

The test methods and test conditions shall be as per the corresponding test defined in Room Temperature Electrical Measurements.

The drift values ( $\Delta$ ) shall not be exceeded for each characteristic specified. The corresponding absolute limit values for each characteristic shall not be exceeded.

Characteristics	Symbols	Limits			Units
		Drift Value $\Delta$	Absolute		
			Min	Max	
Gate Reverse Leakage Current	$I_{GSS}$	$\pm 50$ or (1) $\pm 100\%$	-	-100	pA
Gate Source Cut-off Voltage Variant 01 Variant 02 Variant 03	$V_{GS(off)}$	$\pm 10\%$	-4 -2 -0.5	-10 -5 -3	V
Drain Current Variant 01 Variant 02 Variant 03	$I_{DSS}$	$\pm 15\%$	50 25 5	150 75 30	mA

**NOTES:**

1. Whichever is the greater referred to the initial value.

2.6

INTERMEDIATE AND END-POINT ELECTRICAL MEASUREMENTS

Unless otherwise specified, the measurements shall be performed at  $T_{amb}=+22 \pm 3^{\circ}C$ .

The test methods and test conditions shall be as per the corresponding test defined in Room Temperature Electrical Measurements.

The limit values for each characteristic shall not be exceeded.

Characteristics	Symbols	Limits		Units
		Min	Max	
Gate Reverse Leakage Current	$I_{GSS}$	-	-100	pA
Gate Source Cut-off Voltage Variant 01 Variant 02 Variant 03	$V_{GS(off)}$	-4 -2 -0.5	-10 -5 -3	V
Drain Current Variant 01 Variant 02 Variant 03	$I_{DSS}$	50 25 5	150 75 30	mA

2.7 HIGH TEMPERATURE REVERSE BIAS BURN-IN CONDITIONS  
MIL-STD-750, Test Method 1039, Condition A

Characteristics	Symbols	Test Conditions	Units
Ambient Temperature	$T_{amb}$	+150(+0-5)	°C
Drain-Source Voltage	$V_{DS}$	0	V
Gate-Source Voltage	$V_{GS}$	-28	V
Duration	t	168 to 264	Hours

2.8 OPERATING LIFE CONDITIONS

The conditions shall be as specified for High Temperature Reverse Bias Burn-in except the duration shall be as specified in the ESCC Generic Specification.