



**CONNECTOR SAVERS FOR
ELECTRICAL, CIRCULAR CONNECTORS
3401/044, 3401/052 AND 3401/056
ESCC Detail Specification No. 3401/063**

**ISSUE 1
October 2002**



| | | | |
|---|---------------------------|--|--------------------|
|  | ESCC Detail Specification | | PAGE ii ISSUE 1 |
|---|---------------------------|--|--------------------|

LEGAL DISCLAIMER AND COPYRIGHT

European Space Agency, Copyright © 2002. All rights reserved.

The European Space Agency disclaims any liability or responsibility, to any person or entity, with respect to any loss or damage caused, or alleged to be caused, directly or indirectly by the use and application of this ESCC publication.

This publication, without the prior permission of the European Space Agency and provided that it is not used for a commercial purpose, may be:

- copied in whole in any medium without alteration or modification.
- copied in part, in any medium, provided that the ESCC document identification, comprising the ESCC symbol, document number and document issue, is removed.



europaean space agency
agence spatiale européenne

Pages 1 to 23

**CONNECTOR SAVERS FOR
ELECTRICAL, CIRCULAR CONNECTORS
3401/044, 3401/052 AND 3401/056
ESA/SCC Detail Specification No. 3401/063**



**space components
coordination group**

| Issue/Rev. | Date | Approved by | |
|--------------|----------------|---------------|---------------------------------------|
| | | SCCG Chairman | ESA Director General or his Deputy |
| Issue 1 | September 1994 | | |
| Revision 'A' | September 1998 | | |
| | | | |
| | | | |

TABLE OF CONTENTS

| | | <u>Page</u> |
|-----------|--|-------------|
| 1. | <u>GENERAL</u> | 5 |
| 1.1 | Scope | 5 |
| 1.2 | Range of Components | 5 |
| 1.3 | Maximum Ratings | 5 |
| 1.4 | Parameter Derating Information | 5 |
| 1.5 | Physical Dimensions | 5 |
| 2. | <u>APPLICABLE DOCUMENTS</u> | 5 |
| 3. | <u>TERMS, DEFINITIONS, ABBREVIATIONS, SYMBOLS AND UNITS</u> | 18 |
| 4. | <u>REQUIREMENTS</u> | 18 |
| 4.1 | General | 18 |
| 4.2 | Deviations from Generic Specification | 18 |
| 4.2.1 | Deviations from Special In-process Controls | 18 |
| 4.2.2 | Deviations from Final Production Tests | 18 |
| 4.2.3 | Deviations from Burn-in and Electrical Measurements | 18 |
| 4.2.4 | Deviations from Qualification Tests | 18 |
| 4.2.5 | Deviations from Lot Acceptance Tests | 18 |
| 4.3 | Mechanical Requirements | 18 |
| 4.3.1 | Dimension Check | 18 |
| 4.3.2 | Weight | 18 |
| 4.3.3 | Contact Capability | 18 |
| 4.3.4 | Contact Retention | 19 |
| 4.3.5 | Mating and Unmating Forces | 19 |
| 4.3.6 | Insert Retention | 19 |
| 4.3.7 | Jackscrew Retention | 19 |
| 4.3.8 | Contact Insertion and Withdrawal Forces | 19 |
| 4.3.9 | Engagement and Separation Forces | 19 |
| 4.3.10 | Oversize Pin Exclusion | 19 |
| 4.3.11 | Probe Damage | 19 |
| 4.3.12 | Solderability | 19 |
| 4.4 | Materials and Finishes | 19 |
| 4.4.1 | Shell, Coupling Ring and Nuts | 19 |
| 4.4.2 | Inserts | 19 |
| 4.4.3 | Contacts | 19 |
| 4.4.4 | Contact Retaining Clip | 19 |
| 4.4.5 | Guiding and Locking Devices | 19 |
| 4.4.6 | Magnetism Level | 20 |
| 4.5 | Marking | 20 |
| 4.5.1 | General | 20 |
| 4.5.2 | Contact Identification | 20 |
| 4.5.3 | The SCC Component Number | 20 |
| 4.5.4 | Characteristics | 20 |
| 4.5.5 | Traceability Information | 21 |
| 4.5.6 | Marking of Small Components | 22 |
| 4.6 | Electrical Measurements | 22 |
| 4.6.1 | Electrical Measurements at Room Temperature | 22 |
| 4.6.2 | Electrical Measurements at High and Low Temperatures | 22 |
| 4.6.3 | Circuit for Electrical Measurements | 22 |
| 4.7 | Burn-in and Electrical Measurements | 22 |
| 4.8 | Environmental and Endurance Tests | 22 |

**ESC**ESA/SCC Detail Specification
No. 3401/063

PAGE 4

ISSUE 1

TABLES

| | <u>Page</u> |
|---|-------------|
| 1(a) Range of Components | 6 |
| 1(b) Maximum Ratings | 7 |
| 2 Electrical Measurements at Room Temperature | 23 |
| 3 Not applicable | N/A |
| 4 Not applicable | N/A |
| 5 Not applicable | N/A |
| 6 Not applicable | N/A |

FIGURES

| | |
|---|-----|
| 1 Parameter Derating Information | N/A |
| 2 Physical Dimensions | 8 |
| 2(a) Physical Dimensions - Savers | 8 |
| 2(b) Physical Dimensions - Contact Arrangements | 11 |
| 2(c) Physical Dimensions - Clacking Positions | 17 |

APPENDICES (Applicable to specific Manufacturers only)

None.

**1. GENERAL****1.1 SCOPE**

This specification details the ratings, physical and electrical characteristics, test and inspection data for Connector Savers for Electrical, Circular Connectors 3401/044, 3401/052 and 3401/056.

It shall be read in conjunction with:

- ESA/SCC Generic Specification No. 3401, Connectors, Electrical, Non-Filtered, Circular and Rectangular.
- ESA/SCC Detail Specification No. 3401/044, Connectors, Electrical, Circular Bayonet Coupling, Removable Crimp Contacts, Based on MIL-C-38999 Series II.
- ESA/SCC Detail Specification No. 3401/052, Connectors, Electrical, Circular Bayonet Coupling, Scoop-proof, Removable Crimp Contacts, Based on MIL-C-38999 Series I.
- ESA/SCC Detail Specification No. 3401/056, Connectors, Electrical, Triple Start Self Locking Coupling, Scoop-proof, Removable Crimp Contacts, Based on MIL-C-38999 Series III.

the requirements of which are supplemented herein.

1.2 RANGE OF COMPONENTS

The different sizes of connectors specified herein, which are also covered by this specification, together with their mechanical characteristics, are given in Table 1(a).

1.3 MAXIMUM RATINGS

The maximum ratings, which shall not be exceeded at any time during use or storage, applicable to the connector savers specified herein, are scheduled in Table 1(b).

1.4 PARAMETER DERATING INFORMATION (FIGURE 1)

Not applicable.

1.5 PHYSICAL DIMENSIONS

The physical dimensions of the connectors specified herein are shown in Figure 2.

2. APPLICABLE DOCUMENTS

The following documents form part of this specification and shall be read in conjunction with it:-

- (a) ESA/SCC Generic Specification No. 3401, Connectors, Electrical, Non-Filtered, Circular and Rectangular.
- (b) ESA/SCC Detail Specification No. 3401/044, Connectors, Electrical, Circular Bayonet Coupling, Removable Crimp Contacts, Based on MIL-C-38999 Series II.
- (c) ESA/SCC Detail Specification No. 3401/052, Connectors, Electrical, Circular Bayonet Coupling, Scoop-proof, Removable Crimp Contacts, Based on MIL-C-38999 Series I.
- (d) ESA/SCC Detail Specification No. 3401/056, Connectors, Electrical, Triple Start Self Locking Coupling, Scoop-proof, Removable Crimp Contacts, Based on MIL-C-38999 Series III.
- (e) MIL-STD-1560, Insert Arrangements for MIL-C-38999 and MIL-C-27599 Electrical Circular Connectors.



TABLE 1(a) - RANGE OF COMPONENTS

TYPE VARIANT 01 - Savers for 3401/052 Connectors (Series I)

| SHELL SIZE | MAX. WEIGHT (g) (1) | MATING TORQUE FOR THE PLUG END MAX. N.m | UNMATING TORQUE FOR THE PLUG END | |
|------------|---------------------|---|----------------------------------|-------------|
| | | | MAX. N.m | MIN. N.m |
| 09 | 25 | 0.9 | 0.9 | 0.2 |
| 11 | 32 | 1.4 | 1.4 | 0.2 |
| 13 | 38 | 1.8 | 1.8 | 0.2 |
| 15 | 45 | 2.3 | 2.3 | 0.3 |
| 17 | 52 | 2.7 | 2.7 | 0.3 |
| 19 | 83 | 3.2 | 3.2 | 0.3 |
| 21 | 105 | 3.6 | 3.6 | 0.6 |
| 23 | 113 | 4.1 | 4.1 | 0.6 |
| 25 | 117 | 4.6 | 4.6 | 0.6 |

NOTES

1. With contacts.

TYPE VARIANT 02 - Savers for 3401/044 Connectors (Series II)

| SHELL SIZE | MAX. WEIGHT (g) (1) | MATING TORQUE FOR THE PLUG END MAX. N.m | UNMATING TORQUE FOR THE PLUG END | |
|------------|---------------------|---|----------------------------------|-------------|
| | | | MAX. N.m | MIN. N.m |
| 08 | 18 | 0.9 | 0.9 | 0.2 |
| 10 | 28 | 1.4 | 1.4 | 0.2 |
| 12 | 34 | 1.8 | 1.8 | 0.2 |
| 14 | 40 | 2.3 | 2.3 | 0.3 |
| 16 | 46 | 2.7 | 2.7 | 0.3 |
| 18 | 76 | 3.2 | 3.2 | 0.3 |
| 20 | 95 | 3.6 | 3.6 | 0.6 |
| 22 | 106 | 4.1 | 4.1 | 0.6 |
| 24 | 112 | 4.6 | 4.6 | 0.6 |

NOTES

1. With contacts.



TABLE 1(a) - RANGE OF COMPONENTS (CONTINUED)

TYPE VARIANT 03 - Savers for 3401/056 Connectors (Series III)

| SHELL SIZE | MAX. WEIGHT (g) (1) | MATING AND UNMATING AXIAL FORCE FOR THE PLUG END (N) | | MATING TORQUE FOR THE PLUG END MAX. N.m | UNMATING TORQUE FOR THE PLUG END | |
|------------|---------------------|--|-----|---|----------------------------------|-------------|
| | | MIN | MAX | | MAX. N.m | MIN. N.m |
| 09 | 23 | 2.0 | 111 | 0.9 | 0.9 | 0.2 |
| 11 | 32 | 2.0 | 111 | 1.4 | 1.4 | 0.2 |
| 13 | 36 | 2.0 | 133 | 1.8 | 1.8 | 0.2 |
| 15 | 44 | 2.0 | 133 | 2.3 | 2.3 | 0.3 |
| 17 | 51 | 2.0 | 156 | 2.7 | 2.7 | 0.3 |
| 19 | 80 | 2.0 | 156 | 3.2 | 3.2 | 0.3 |
| 21 | 100 | 2.0 | 156 | 3.6 | 3.6 | 0.6 |
| 23 | 111 | 2.0 | 156 | 4.1 | 4.1 | 0.6 |
| 25 | 115 | 2.0 | 156 | 4.6 | 4.6 | 0.6 |

NOTES

1. With contacts.

TABLE 1(b) - MAXIMUM RATINGS

| No. | CHARACTERISTICS | SYMBOL | MAXIMUM RATING | | UNIT | |
|-----|------------------------------------|---|----------------|-------|------|------|
| | | | MIN | MAX | | |
| 1 | Working Voltage (Sea Level) (1) | Service rating N Service rating M Service rating I Service rating II | U _R | - | 250 | Vrms |
| | | | | - | 325 | |
| | | | | - | 450 | |
| | | | | - | 575 | |
| 2 | Operating Temperature Range | T _{op} | - 65 | + 200 | °C | |
| 3 | Storage Temperature Range | T _{stg} | - 65 | + 200 | °C | |

NOTES

1. See Para. 4.5.4.3.

FIGURE 1 - PARAMETER DERATING INFORMATION

Not applicable.



FIGURE 2 - PHYSICAL DIMENSIONS

**FIGURE 2(a) - SAVERS
TYPE VARIANT 01 - SAVERS FOR 3401/052 CONNECTORS (SERIES I)**

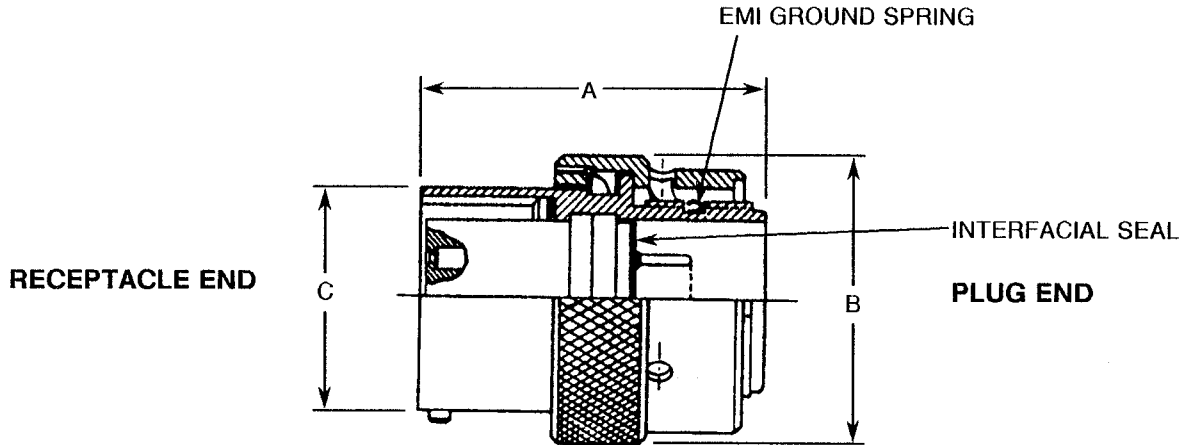

| SHELL SIZE | 09 | 11 | 13 | 15 | 17 | 19 | 21 | 23 | 25 |
|------------|-------|-------|-------|-------|-------|-------|-------|-------|-------|
| A Max | 38.10 | 38.10 | 38.10 | 38.10 | 38.10 | 38.10 | 38.10 | 38.10 | 38.10 |
| B Max | 22.86 | 26.16 | 30.61 | 33.66 | 36.83 | 39.75 | 42.93 | 45.59 | 48.77 |
| C Max | 14.60 | 17.80 | 21.60 | 24.80 | 28.00 | 30.70 | 33.90 | 37.00 | 40.20 |

NOTES

1. All dimensions are in millimetres.



FIGURE 2 - PHYSICAL DIMENSIONS (CONTINUED)

**FIGURE 2(a) - SAVERS
TYPE VARIANT 02 - SAVERS FOR 3401/044 CONNECTORS (SERIES II)**

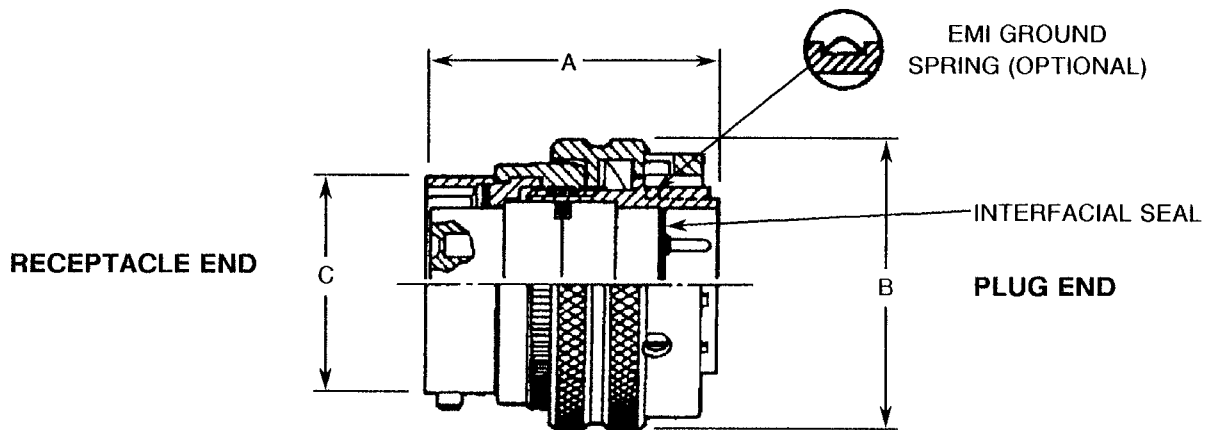

| SHELL SIZE | 08 | 10 | 12 | 14 | 16 | 18 | 20 | 22 | 24 |
|------------|-------|-------|-------|-------|-------|-------|-------|-------|-------|
| A Max | 30.50 | 30.50 | 30.50 | 30.50 | 30.50 | 30.50 | 30.50 | 30.50 | 30.50 |
| B Max | 19.10 | 21.80 | 26.20 | 29.40 | 32.50 | 35.70 | 38.90 | 41.70 | 44.90 |
| C Max | 12.00 | 15.00 | 13.10 | 22.30 | 25.40 | 28.60 | 31.80 | 35.00 | 38.10 |

NOTES

1. All dimensions are in millimetres.



FIGURE 2 - PHYSICAL DIMENSIONS (CONTINUED)

FIGURE 2(a) - SAVERS

TYPE VARIANT 03 - SAVERS FOR 3401/056 CONNECTORS (SERIES III)

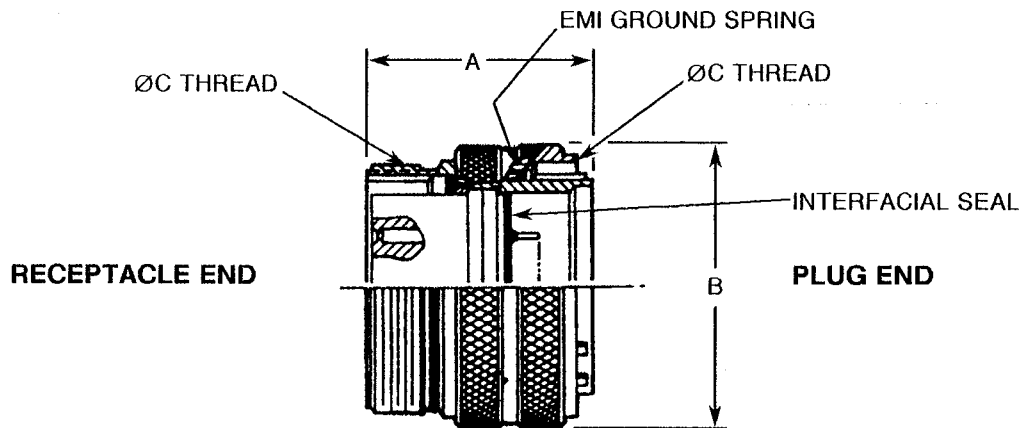

| SHELL SIZE | MILLIMETRES | | ØC THREAD (CLASS 2A) |
|------------|-------------|-------|-----------------------|
| | A Max | B Max | |
| 09 | 38.10 | 21.80 | 0.6250-0.1P-0.3L-TS-2 |
| 11 | 38.10 | 24.60 | 0.7500-0.1P-0.3L-TS-2 |
| 13 | 38.10 | 29.00 | 0.8750-0.1P-0.3L-TS-2 |
| 15 | 38.10 | 32.20 | 1.0000-0.1P-0.3L-TS-2 |
| 17 | 38.10 | 35.30 | 1.1875-0.1P-0.3L-TS-2 |
| 19 | 38.10 | 38.10 | 1.2500-0.1P-0.3L-TS-2 |
| 21 | 38.10 | 41.30 | 1.3750-0.1P-0.3L-TS-2 |
| 23 | 38.10 | 44.50 | 1.5000-0.1P-0.3L-TS-2 |
| 25 | 38.10 | 47.60 | 1.6250-0.1P-0.3L-TS-2 |



FIGURE 2 - PHYSICAL DIMENSIONS (CONTINUED)

**FIGURE 2(b) - HIGH DENSITY CONTACT ARRANGEMENTS - FRONT VIEW MALE INSERT
TYPE VARIANT 01 - SAVERS FOR 3401/052 CONNECTORS (SERIES I)
TYPE VARIANT 03 - SAVERS FOR 3401/056 CONNECTORS (SERIES III)**

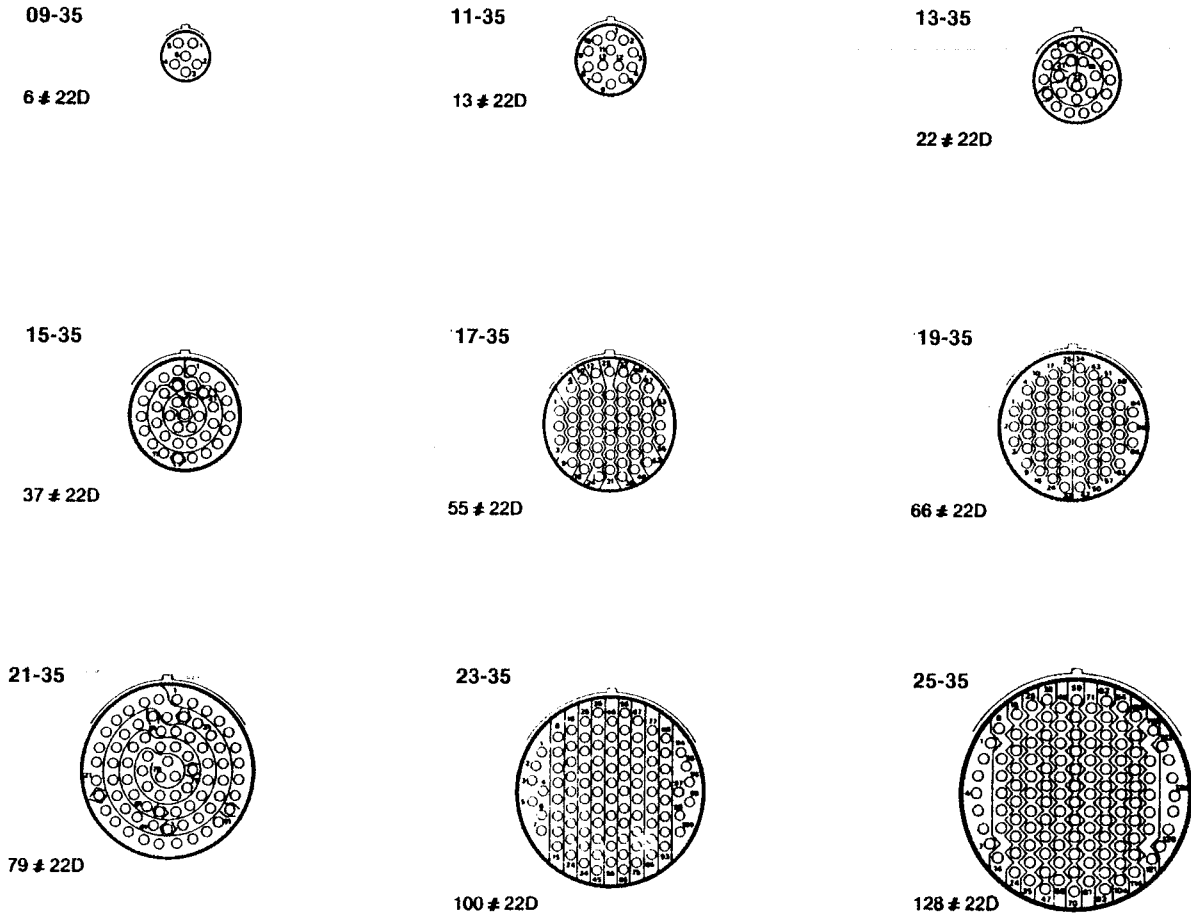

NOTES

1. Contact locations and identifications in conformity with MIL-STD-1560.
2. Both sides of the inserts shall be marked.



FIGURE 2 - PHYSICAL DIMENSIONS (CONTINUED)

FIGURE 2(b) - STANDARD CONTACT ARRANGEMENTS - FRONT VIEW MALE INSERT
TYPE VARIANT 01 - SAVERS FOR 3401/052 CONNECTORS (SERIES I)
TYPE VARIANT 03 - SAVERS FOR 3401/056 CONNECTORS (SERIES III)

09-98



3 # 20

11-98



6 # 20

13-98



10 # 20

15-19



19 # 20

17-26

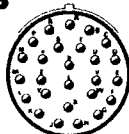

26 # 20

19-32

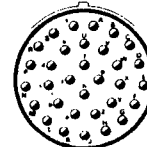

32 # 20

21-41

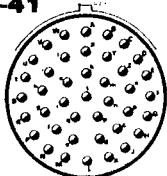

41 # 20

23-53

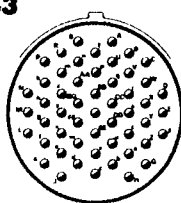

53 # 20

25-61

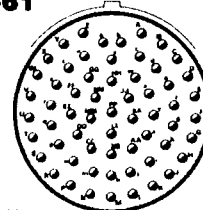

61 # 20

NOTES

1. Contact locations and identifications in conformity with MIL-STD-1560.
2. Both sides of the inserts shall be marked.



FIGURE 2 - PHYSICAL DIMENSIONS (CONTINUED)

**FIGURE 2(b) - SPECIAL CONTACT ARRANGEMENTS - FRONT VIEW MALE INSERT
TYPE VARIANT 01 - SAVERS FOR 3401/052 CONNECTORS (SERIES I)
TYPE VARIANT 03 - SAVERS FOR 3401/056 CONNECTORS (SERIES III)**

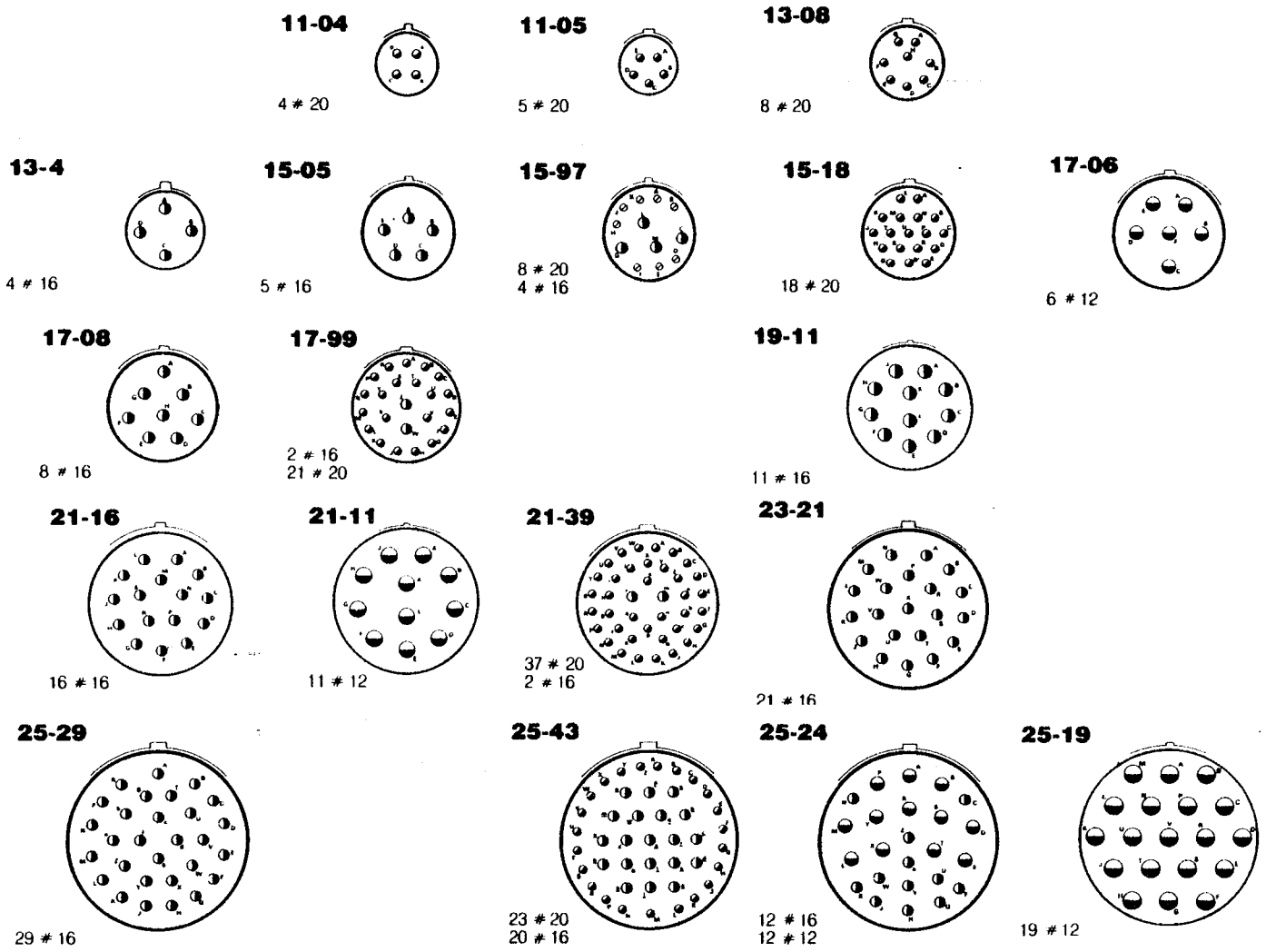

NOTES

1. Contact locations and identifications in conformity with MIL-STD-1560.
2. Both sides of the inserts shall be marked.

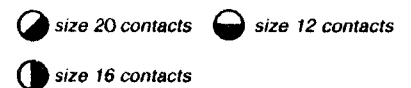



FIGURE 2 - PHYSICAL DIMENSIONS (CONTINUED)

**FIGURE 2(b) - HIGH DENSITY CONTACT ARRANGEMENTS - FRONT VIEW MALE INSERT
TYPE VARIANT 02 - SAVERS FOR 3401/044 CONNECTORS (SERIES II)**

08-35



6 # 22D

10-35



13 # 22D

12-35

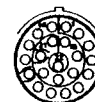

22 # 22D

14-35

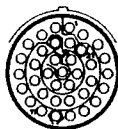

37 # 22D

16-35

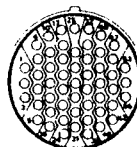

55 # 22D

18-35

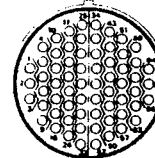

66 # 22D

20-35

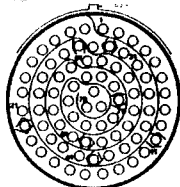

79 # 22D

22-35

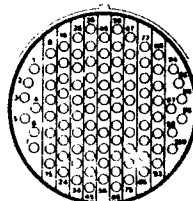

100 # 22D

24-35

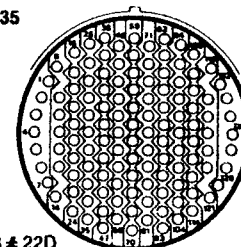

128 # 22D

NOTES

1. Contact locations and identifications in conformity with MIL-STD-1560.
2. Both sides of the inserts shall be marked.



FIGURE 2 - PHYSICAL DIMENSIONS (CONTINUED)

**FIGURE 2(b) - SPECIAL CONTACT ARRANGEMENTS - FRONT VIEW MALE INSERT
TYPE VARIANT 02 - SAVERS FOR 3401/044 CONNECTORS (SERIES II)**

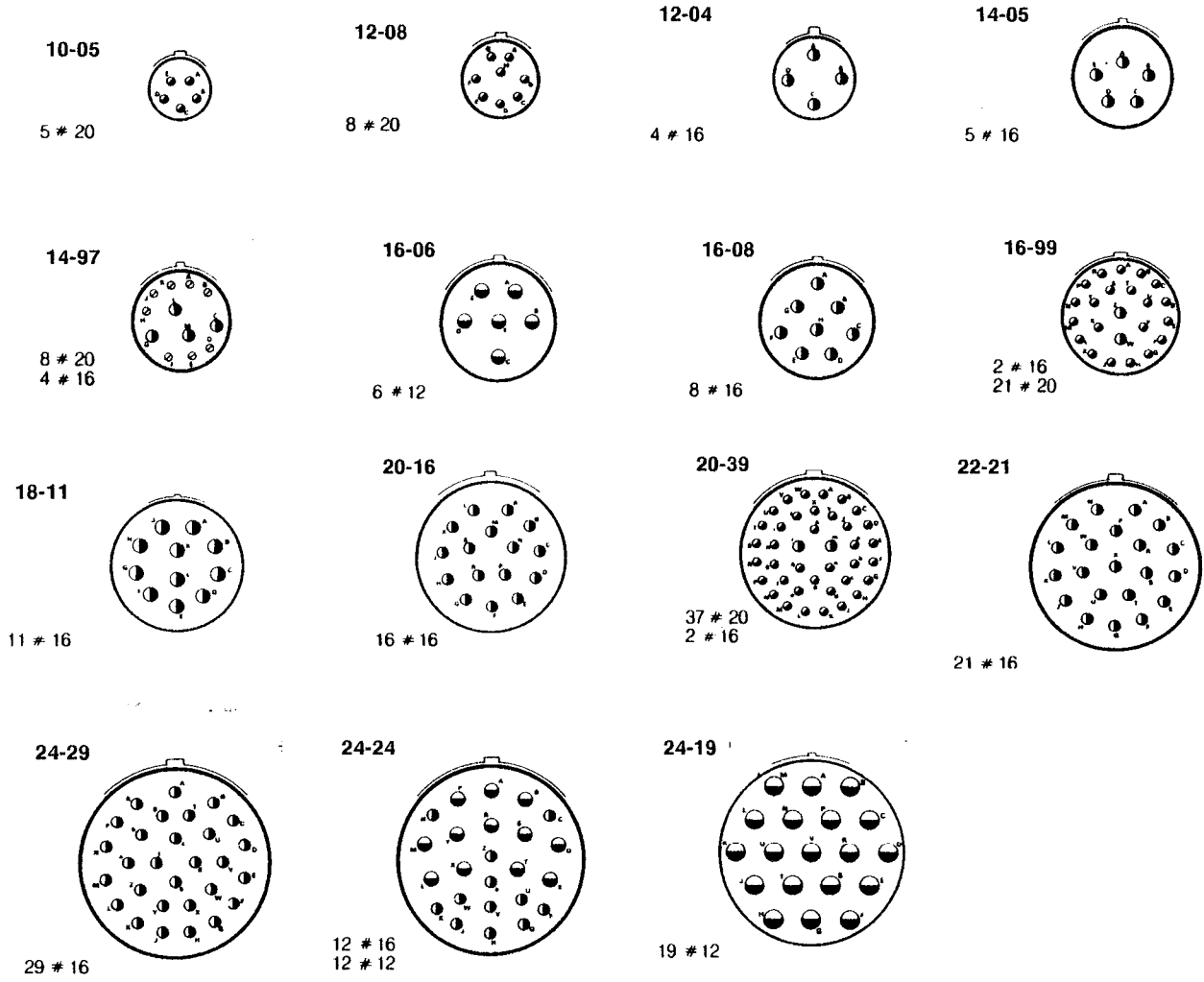

NOTES

- Contact locations and identifications in conformity with MIL-STD-1560.
- Both sides of the inserts shall be marked.



 contacts # 20
 size 20 contacts
  contacts # 12
 size 12 contacts
 contacts # 16
 size 16 contacts



FIGURE 2 - PHYSICAL DIMENSIONS (CONTINUED)

**FIGURE 2(b) - STANDARD CONTACT ARRANGEMENTS - FRONT VIEW MALE INSERT
TYPE VARIANT 02 - SAVERS FOR 3401/044 CONNECTORS (SERIES II)**

08-98



3 # 20

10-98



6 # 20

12-98



10 # 20

14-18

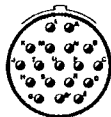

18 # 20

16-26

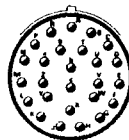

26 # 20

18-32

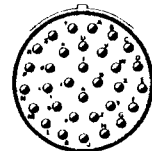

32 # 20

20-41

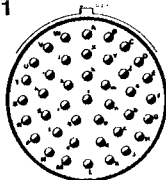

41 # 20

22-55

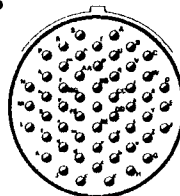

55 # 20

24-61

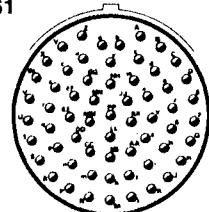

61 # 20

NOTES

1. Contact locations and identifications in conformity with MIL-STD-1560.
2. Both sides of the inserts shall be marked.



FIGURE 2 - PHYSICAL DIMENSIONS (CONTINUED)

FIGURE 2(c) - CLOCKING POSITIONS

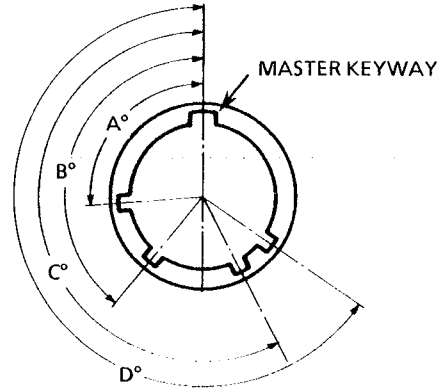

Receptacle front end view

NOTES

1. The clocking position is determined by the different angles of the secondary keyways, the insert being always in the same position with respect to the master keyway position which is fixed.

| SHELL SIZE | ANGLES | CLOCKING POSITIONS | | | | | |
|------------|--------|--------------------|-----|-----|-----|-----|-----|
| | | N | A | B | C | D | E |
| 09 | A° | 105 | 102 | 80 | 35 | 64 | 91 |
| | B° | 140 | 132 | 118 | 140 | 155 | 131 |
| | C° | 215 | 248 | 230 | 205 | 234 | 197 |
| | D° | 265 | 320 | 312 | 275 | 304 | 240 |
| 11 | A° | 95 | 113 | 90 | 53 | 119 | 51 |
| | B° | 141 | 156 | 145 | 156 | 146 | 141 |
| | C° | 208 | 182 | 195 | 220 | 176 | 184 |
| | D° | 236 | 292 | 252 | 255 | 298 | 242 |
| 13 | A° | 95 | 113 | 90 | 53 | 119 | 51 |
| | B° | 141 | 156 | 145 | 156 | 146 | 141 |
| | C° | 208 | 182 | 195 | 220 | 176 | 184 |
| | D° | 236 | 292 | 252 | 255 | 298 | 242 |
| 15 | A° | 95 | 113 | 90 | 53 | 119 | 51 |
| | B° | 141 | 156 | 145 | 156 | 146 | 141 |
| | C° | 208 | 182 | 195 | 220 | 176 | 184 |
| | D° | 236 | 292 | 252 | 255 | 298 | 242 |
| 17 | A° | 80 | 135 | 49 | 66 | 62 | 79 |
| | B° | 142 | 170 | 169 | 140 | 145 | 153 |
| | C° | 196 | 200 | 200 | 200 | 180 | 197 |
| | D° | 293 | 310 | 244 | 257 | 280 | 272 |
| 19 | A° | 80 | 135 | 49 | 66 | 62 | 79 |
| | B° | 142 | 170 | 169 | 140 | 145 | 153 |
| | C° | 196 | 200 | 200 | 200 | 180 | 197 |
| | D° | 293 | 310 | 244 | 257 | 280 | 272 |
| 21 | A° | 80 | 135 | 49 | 66 | 62 | 79 |
| | B° | 142 | 170 | 169 | 140 | 145 | 153 |
| | C° | 196 | 200 | 200 | 200 | 180 | 197 |
| | D° | 293 | 310 | 244 | 257 | 280 | 272 |
| 23 | A° | 80 | 135 | 49 | 66 | 62 | 79 |
| | B° | 142 | 170 | 169 | 140 | 145 | 153 |
| | C° | 196 | 200 | 200 | 200 | 180 | 197 |
| | D° | 293 | 310 | 244 | 257 | 280 | 272 |
| 25 | A° | 80 | 135 | 49 | 66 | 62 | 79 |
| | B° | 142 | 170 | 169 | 140 | 145 | 153 |
| | C° | 196 | 200 | 200 | 200 | 180 | 197 |
| | D° | 293 | 310 | 244 | 257 | 280 | 272 |

| | | |
|---|--|----------------------------|
|  | <p style="text-align: center;">ESA/SCC Detail Specification No. 3401/063</p> | <p>PAGE 18 ISSUE 1</p> |
|---|--|----------------------------|

3. TERMS, DEFINITIONS, ABBREVIATIONS, SYMBOLS AND UNITS

For the purpose of this specification, the terms, definitions, abbreviations, symbols and units specified in ESA/SCC Basic Specification No. 21300 shall apply.

4. REQUIREMENTS

4.1 GENERAL

The complete requirements for procurement of the connectors specified herein are stated in this specification and ESA/SCC Generic Specification No. 3401. Deviations from the Generic Specification applicable to this specification only, are listed in Para 4.2.

Deviations from the applicable Generic Specification and this Detail Specification, formally agreed with specific Manufacturers on the basis that the alternative requirements are equivalent to the ESA/SCC requirements and do not affect the components' reliability, are listed in the Appendices attached to this specification.

4.2 DEVIATIONS FROM GENERIC SPECIFICATION

4.2.1 Deviations from Special In-process Controls

None.

4.2.2 Deviations from Final Production Tests (Chart II)

- (a) Para. 9.4, Contact Capability: Not applicable.
- (b) Para. 9.5, Magnetism Level: Not applicable.
- (c) Para. 9.8, Installation of Contacts into Insert: Not applicable.
- (d) Para. 9.9, Seal Test: Not applicable.

4.2.3 Deviations from Burn-in and Electrical Measurements (Chart III)

Not applicable.

4.2.4 Deviations from Qualification Tests (Chart IV)

Qualification tests are not applicable.

4.2.5 Deviations from Lot Acceptance Tests (Chart V)

Lot Acceptance tests are not applicable.

4.3 MECHANICAL REQUIREMENTS

4.3.1 Dimension Check

The dimensions of the connector savers specified herein shall be verified in accordance with the requirements set out in Para 9.6 of ESA/SCC Generic Specification No. 3401 and shall conform to those shown in Figure 2 of this specification.

4.3.2 Weight

The maximum weight of the connector savers specified herein, without contacts, shall be as specified in Table 1(a).

4.3.3 Contact Capability

Not applicable.

**4.3.4 Contact Retention (In Insert)**

Not applicable.

4.3.5 Mating and Unmating Forces

The forces applied for mating and unmating of the connectors (axial and torque) shall conform to the values specified in Table 1(a).

4.3.6 Insert Retention (In Shell)

Not applicable.

4.3.7 Jackscrew Retention

Not applicable.

4.3.8 Contact Insertion and Withdrawal Forces

Not applicable.

4.3.9 Engagement and Separation Forces

Not applicable.

4.3.10 Oversize Pin Exclusion

Not applicable.

4.3.11 Probe Damage

Not applicable.

4.3.12 Solderability

Not applicable.

4.4 MATERIALS AND FINISHES

The materials and finishes shall be as specified herein. Where a definite material is not specified, a material which will enable the connectors specified herein to meet the performance requirements of this specification shall be used. Acceptance or approval of any constituent material does not guarantee acceptance of the finished product.

4.4.1 Shell, Coupling Ring and Nuts

The shell and coupling ring shall be made of aluminium alloy, dull low-reflective electroless nickel plated.

4.4.2 Inserts

Bonded sandwich: Silicone/thermosetting or thermoplastic insert/silicone.

4.4.3 Contacts

As specified in the ESA/SCC Detail Specification No. 3401/058.

4.4.4 Contact Retaining Clip

Not applicable.

4.4.5 Guiding and Locking Devices

Not applicable.

4.4.6 Magnetism Level

Not applicable.

4.5 MARKING

4.5.1 General

The marking of all components delivered to this specification shall be in accordance with the requirements of ESA/SCC Basic Specification No. 21700 and the following paragraphs. Each component shall be marked in respect of:-

- (a) Contact Identification.
- (b) The SCC Component Number.
- (c) Characteristics.
- (d) Traceability information.

4.5.2 Contact Identification

Contact identification shall be marked in accordance with Figure 2(b).

4.5.3 The SCC Component Number

The SCC component number shall be constituted and marked as follows:

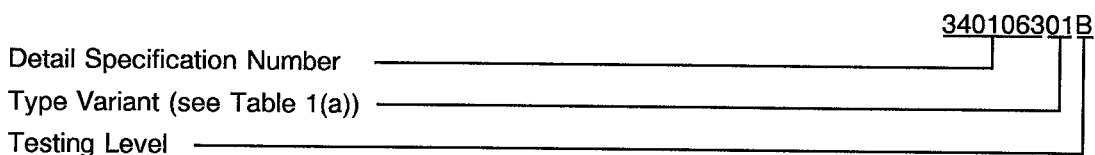

4.5.4 Characteristics

The characteristics to be marked in the following order of precedence are:-

- (a) Grounding. (For Variant 02 only).
- (b) Lock ring.
- (c) Contact arrangement.
- (d) Type of contact (plug side).
- (e) Clocking position.

The information shall be constituted and marked as follows:-

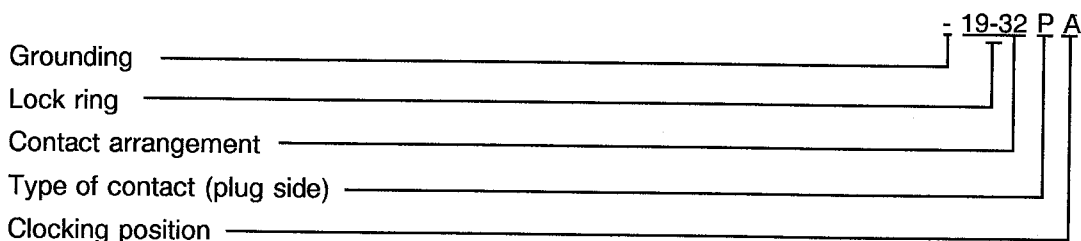

4.5.4.1 Grounding

For Variant 02: Grounding shall be indicated by the letter 'G'. When grounding is not required, the letter 'G' shall be omitted and replaced by a dash (-).

For Variants 01 and 03: Only a dash (-) is applicable.

4.5.4.2 Lock Ring

Lock ring shall be indicated by the letter 'L'. When a lock ring is not required, the letter 'L' shall be omitted and replaced by a dash (-).

4.5.4.3 Contact Arrangements

The number of contacts shall be as shown in Figure 2(b) and contact arrangements shall be indicated by the codes specified hereafter:

TYPE VARIANTS 01 AND 03

| CODE | SERVICE RATING | CODE | SERVICE RATING |
|-------|----------------|-------|----------------|
| 09-35 | M | 17-08 | II |
| 09-98 | I | 17-99 | I |
| 11-35 | M | 19-35 | M |
| 11-98 | I | 19-32 | I |
| 11-01 | II | 19-11 | II |
| 11-05 | I | 21-35 | M |
| 11-04 | I | 21-41 | I |
| 13-35 | M | 21-16 | II |
| 13-98 | I | 21-11 | II |
| 13-08 | I | 21-39 | I |
| 13-26 | M | 23-35 | M |
| 13-4 | I | 23-53 | I |
| 15-35 | M | 23-21 | II |
| 15-19 | I | 25-35 | M |
| 15-05 | I | 25-61 | I |
| 15-97 | I | 25-19 | I |
| 15-18 | I | 25-29 | I |
| 17-35 | M | 25-43 | I |
| 17-26 | I | 25-24 | I |
| 17-06 | I | 25-46 | N |
| 17-28 | I | 25-03 | I |
| | | 25-07 | I |

TYPE VARIANT 02

| CODE | SERVICE RATING | CODE | SERVICE RATING |
|-------|----------------|-------|----------------|
| 08-35 | M | 16-08 | II |
| 08-98 | I | 16-99 | I |
| 10-35 | M | 18-35 | M |
| 10-98 | I | 18-32 | I |
| 10-05 | I | 18-11 | II |
| 12-35 | M | 20-35 | M |
| 12-98 | I | 20-41 | I |
| 12-08 | I | 20-16 | II |
| 12-04 | I | 20-39 | I |
| 14-35 | M | 22-35 | M |
| 14-18 | I | 22-55 | I |
| 14-05 | II | 22-21 | II |
| 14-97 | I | 24-35 | M |
| 16-35 | M | 24-61 | I |
| 16-26 | I | 24-29 | I |
| 16-06 | I | 24-24 | I |

4.5.4.4 Type of Contact

The contact type shall be indicated by the following code letters:-

| CODE LETTER | CONTACT TYPE (PLUG SIDE) |
|-------------|--------------------------|
| P | Male |
| S | Female |

4.5.4.5 Clocking Position

Clocking positions are as shown in Figure 2(c) and shall be designated by the following code letters: A, B, C, D and E. Code letter N indicates the standard clocking position.

4.5.5 Traceability Information

Traceability information shall be marked in accordance with the requirements of ESA/SCC Basic Specification No. 21700.

| | | |
|---|--|----------------------------|
|  | <p style="text-align: center;">ESA/SCC Detail Specification No. 3401/063</p> | <p>PAGE 22 ISSUE 1</p> |
|---|--|----------------------------|

4.5.6 Marking of Small Components

Where it is considered that a component is too small to accommodate the marking as specified above, as much as space permits shall be marked. The order of precedence shall be as specified in Para. 4.5.1. The marking information in full shall accompany each component in its primary package.

4.6 ELECTRICAL MEASUREMENTS

4.6.1 Electrical Measurements at Room Temperature

The parameters to be measured in respect of electrical characteristics are scheduled in Table 2. Unless otherwise specified these measurements shall be performed at $T_{amb} = +22 \pm 3 \text{ }^\circ\text{C}$.

4.6.2 Electrical Measurements at High and Low Temperatures (Table 3)

Not applicable.

4.6.3 Circuit for Electrical Measurements (Figure 4)

Not applicable.

4.7 BURN-IN AND ELECTRICAL MEASUREMENTS (TABLES 4 AND 5)

Not applicable.

4.8 ENVIRONMENTAL AND ENDURANCE TESTS (TABLE 6)

Not applicable.

**TABLE 2 - ELECTRICAL MEASUREMENTS AT ROOM TEMPERATURE**

| NO | CHARACTERISTICS | SYMBOL | ESA/SCC No. 3401 TEST METHOD | TEST CONDITION | LIMITS | | UNIT |
|----|---|----------------|---------------------------------|--|------------------|--------------------------|------|
| | | | | | MIN | MAX | |
| 1 | Insulation Resistance | Ri | Para 9.1.1.1 | Para 9.1.1.1 | 10 000 | - | MΩ |
| 2 | Voltage Proof Leakage Current Service II Service I Service M Service N | I _L | Para 9.1.1.2 | 2300Vrms 1800Vrms 1300Vrms 1000Vrms | - - - - | 2.0 2.0 2.0 2.0 | mA |
| 3 | Mated Shell Conductivity (1) (Voltage Drop) | Vd | Para. 9.1.1.4 | Para. 9.1.1.4 | Not applicable | | mV |

NOTES

1. Applicable to mated connectors with grounding option.

TABLES 3, 4, 5 AND 6

Not applicable.