



Pages 1 to 22

**CONNECTORS, ELECTRICAL, RECTANGULAR,
MICROMINIATURE, SOLDER BUCKET CONTACTS,
WITH EMI BACKSHELL
BASED ON TYPE MDM**

ESCC Detail Specification No. 3401/071

**ISSUE 1
May 2003**

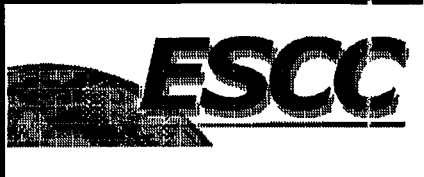

Document Custodian: European Space Agency - see <https://escies.org>

	ESCC Detail Specification No. 3401/071		PAGE i ISSUE 1
--	---	--	-------------------

LEGAL DISCLAIMER AND COPYRIGHT

European Space Agency, Copyright © 2003. All rights reserved.

The European Space Agency disclaims any liability or responsibility, to any person or entity, with respect to any loss or damage caused, or alleged to be caused, directly or indirectly by the use and application of this ESCC publication.

This publication, without the prior permission of the European Space Agency and provided that it is not used for a commercial purpose, may be:

- copied in whole in any medium without alteration or modification.
- copied in part, in any medium, provided that the ESCC document identification, comprising the ESCC symbol, document number and document issue, is removed.



DOCUMENTATION CHANGE NOTICE

(Refer to <https://escies.org> for ESCC DCR content)

DCR No.	CHANGE DESCRIPTION

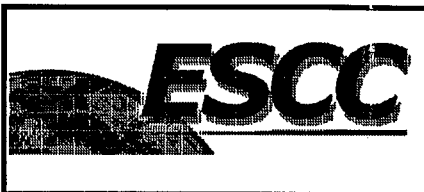

TABLE OF CONTENTS

	<u>Page</u>
1. <u>GENERAL</u>	5
1.1 Scope	5
1.2 Range of Components	5
1.3 Maximum Ratings	5
1.4 Parameter Derating Information	5
1.5 Physical Dimensions	5
1.6 Contact Arrangements	5
2. <u>APPLICABLE DOCUMENTS</u>	5
3. <u>TERMS, DEFINITIONS, ABBREVIATIONS, SYMBOLS AND UNITS</u>	5
4. <u>REQUIREMENTS</u>	14
4.1 General	14
4.2 Deviations from Generic Specification	14
4.2.1 Deviations from Special In-process Controls	14
4.2.2 Deviations from Final Production Tests	14
4.2.3 Deviations from Burn-in and Electrical Measurements	14
4.2.4 Deviations from Qualification Tests	14
4.2.5 Deviations from Lot Acceptance Tests	14
4.3 Mechanical Requirements	14
4.3.1 Dimension Check	14
4.3.2 Weight	15
4.3.3 Contact Capability	15
4.3.4 Contact Retention (In insert)	15
4.3.5 Mating and Unmating Forces	15
4.3.6 Insert Retention (In shell)	15
4.3.7 Jackscrew Retention	15
4.3.8 Contact Insertion and Withdrawal Forces	15
4.3.9 Engagement and Separation Forces	15
4.3.10 Oversize Pin Exclusion	15
4.3.11 Probe Damage	15
4.3.12 Solderability	16
4.4 Materials and Finishes	16
4.4.1 Shells	16
4.4.2 Inserts	16
4.4.3 Contacts	16
4.4.4 Seals, Interfacial	16
4.4.5 Rear Potting	16
4.4.6 EMI Backshell	16
4.5 Marking	16
4.5.1 General	16
4.5.2 The ESCC Component Number	17
4.5.3 Characteristics	17
4.5.4 Traceability Information	18
4.6 Electrical Measurements	18
4.6.1 Electrical Measurements at Room Temperature	18
4.6.2 Electrical Measurements at High and Low Temperatures	18
4.6.3 Circuits for Electrical Measurements	18
4.7 Burn-in and Electrical Measurements	18



	<u>Page</u>
4.8 Environmental and Endurance Tests	20
4.8.1 Measurements and Inspection on Completion of Environmental Tests	20
4.8.2 Measurements and Inspections at Intermediate Points during Endurance Tests	20
4.8.3 Measurements and Inspections on Completion of Endurance Tests	20
4.8.4 Conditions for Operating Life Test	20
4.8.5 Electrical Circuit for Operating Life Test	20
4.8.6 Conditions for High Temperature Storage Test	20

TABLES

1(a) Range of Components	6
1(b) Maximum Ratings	6
2 Electrical Measurements at Room Temperature	18
3 Not applicable	
4 Not applicable	
5 Not applicable	
6 Measurements and Inspections on Completion of Environmental and Endurance Tests	21

FIGURES

1 Parameter Derating Information	7
2 Physical Dimensions	8
3 Contact Arrangements	13
4 Gauge Fixture	19

APPENDICES (Applicable to specific Manufacturers only)

None.



1. GENERAL

1.1 SCOPE

This specification details the values, physical and electrical characteristics, test and inspection data for Electrical, Rectangular, Microminiature Connectors with non-removable Solder Bucket Contacts and EMI Backshell, based on Type MDM.

It shall be read in conjunction with:

- (a) ESCC Generic Specification No. 3401, Connectors, Electrical, Rectangular and Circular.

1.2 RANGE OF COMPONENTS

The different sizes of the basic type connectors specified herein, which are also covered by this specification, together with their mechanical characteristics, are scheduled in Table 1(a).

1.3 MAXIMUM RATINGS

The maximum ratings, which shall not be exceeded at any time during use or storage, applicable to the connectors specified herein, are scheduled in Table 1(b).

1.4 PARAMETER DERATING INFORMATION

The derating information applicable to the connectors specified herein is shown in Figure 1.

1.5 PHYSICAL DIMENSIONS

The physical characteristics of the connectors specified herein are shown in Figure 2.

1.6 CONTACT ARRANGEMENTS

Contact arrangements are shown in Figure 3.

2. APPLICABLE DOCUMENTS

The following documents form part of this specification and shall be read in conjunction with it:-

- (a) ESCC Generic Specification No. 3401, Connectors, Electrical, Circular and Rectangular.
- (b) MIL-G-45204, Gold Plating, Electro-deposited.
- (c) MIL-C-14550, Copper Plating, Electro-deposited.
- (d) MIL-PRF-83513, Generic Specification for Connectors, Electrical, Rectangular, Microminiature, Polarised Shell.

3. TERMS, DEFINITIONS, ABBREVIATIONS, SYMBOLS AND UNITS

For the purpose of this specification, the terms, definitions, abbreviations, symbols and units specified in ESCC Basic Specification No. 21300 shall apply.

TABLE 1(a) - RANGE OF COMPONENTS

SHELL SIZE	MAX. WEIGHT (grammes) (1)	MAX. WEIGHT OF EMI BACKSHELL (grammes)	MATING FORCE (N.Max.)	UNMATING FORCE	
				N.Max.	N.Min.
9	2.2	2.1	20	20	1.3
15	3.0	2.8	33	33	2.0
21	3.8	3.5	47	47	2.9
25	4.3	4.0	55	55	3.5
31	5.1	4.7	69	69	4.3
37	5.9	5.4	82	82	5.1

NOTES

1. Connector with contacts and rear potting. Add 0.4 grammes for connectors with floating mounts and 1.0 gramme for connectors with captive nuts.

TABLE 1(b) - MAXIMUM RATINGS

NO.	CHARACTERISTICS	SYMBOL	MAXIMUM RATING	UNIT	REMARKS
1	Working Voltage Sea Level	U_R	150	Vrms	Note 1
2	Rated Current	I_R	3.0	A	Note 2
3	Operating Temperature Range	T_{op}	- 55 to + 125	°C	T_{amb}
4	Storage Temperature Range	T_{stg}	- 65 to + 125	°C	-
5	Soldering Temperature	T_{sol}	+ 260	°C	Note 3

NOTES

1. Between contacts, and contact and shell.
2. I_R requires derating if the number of current-carrying contacts in the connector is 2 or greater. See Figure 1(b).
3. Duration 5 seconds maximum and the same contact shall not be resoldered until 3 minutes have elapsed.



FIGURE 1 - PARAMETER DERATING INFORMATION

FIGURE 1(a) - WORKING VOLTAGE VERSUS ALTITUDE

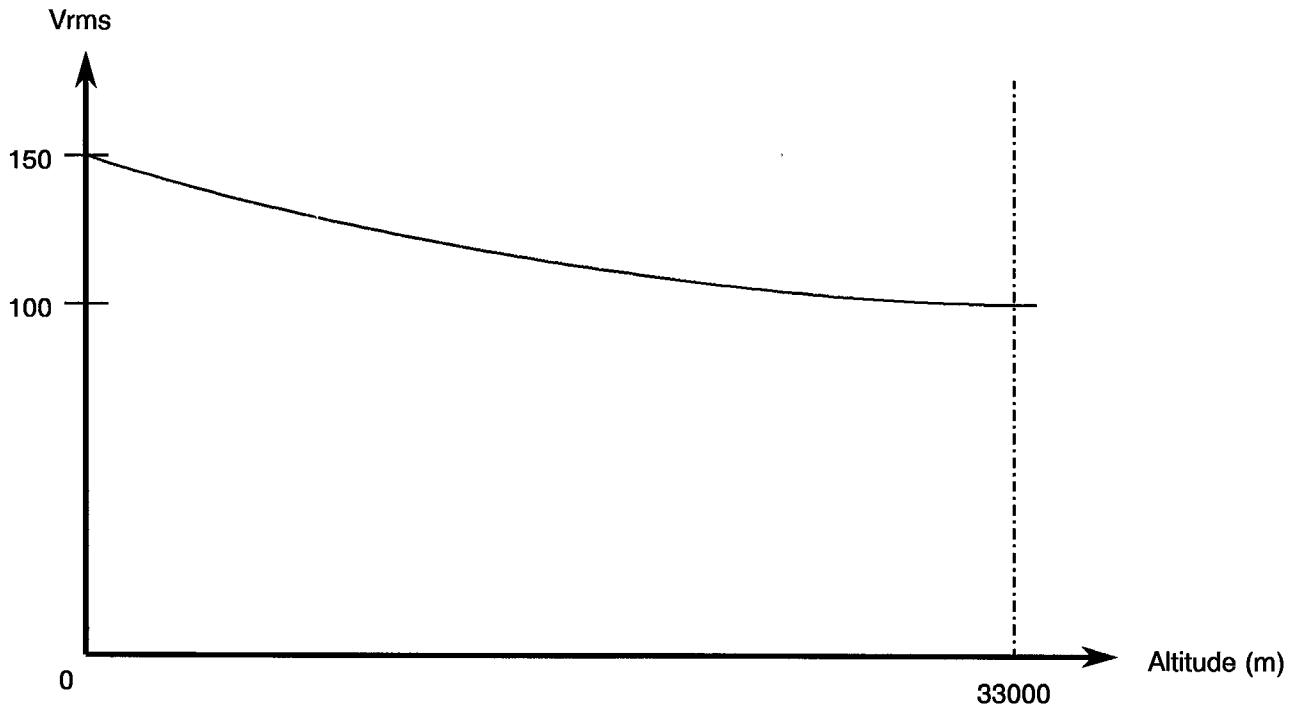

FIGURE 1(b) - MAXIMUM CURRENT VERSUS NUMBER OF CONTACTS

NUMBER OF CURRENT-CARRYING CONTACTS PER CONNECTOR	MAXIMUM CURRENT PER CONTACT (A)
2 - 4	2.4
5 - 14	2.2
15 and over	1.7

FIGURE 2 - PHYSICAL DIMENSIONS

FIGURE 2.1(a) - CONNECTOR SHELLS

PLUG MALE CONTACTS

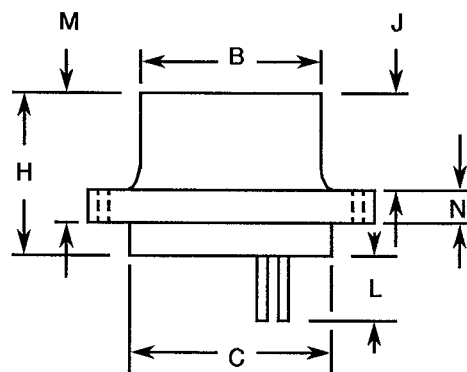
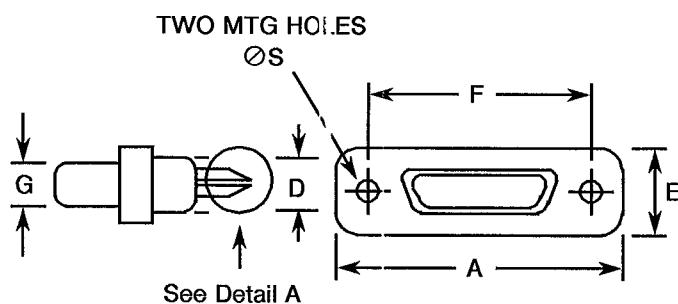

DETAIL A

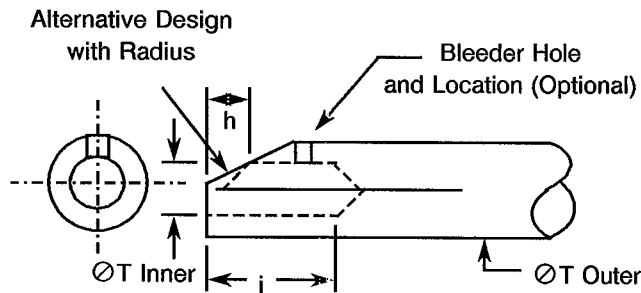

Shell Size	A Max.	B Max.	C Max.	D Max.	E Max.	E		G Max.	H Max.	J Max.	L Max.	M Max.	N		ØS	
						Min.	Max.						Min.	Max.	Min.	Max.
9	19.94	8.46	10.16	6.86	7.82	14.22	14.48	4.69	10.57	4.72	2.80	7.26	2.23	2.49	2.23	2.39
15	23.75	12.27	13.97	6.86	7.82	18.03	18.29	4.69	10.57	4.72	2.80	7.26	2.23	2.49	2.23	2.39
21	27.56	16.08	17.78	6.86	7.82	21.84	22.10	4.69	10.57	4.72	2.80	7.26	2.23	2.49	2.23	2.39
25	30.10	18.62	20.32	6.86	7.82	24.38	24.64	4.69	10.57	4.72	2.80	7.26	2.23	2.49	2.23	2.39
31	33.91	22.43	24.13	6.86	7.82	28.19	28.45	4.69	10.57	4.72	2.80	7.26	2.23	2.49	2.23	2.39
37	37.72	26.24	27.94	6.86	7.82	32.00	32.26	4.69	10.57	4.72	2.80	7.26	2.23	2.49	2.23	2.39

Dimensions for DETAIL A

h		j		ØT	
Min.	Max.	Min.	Max.	Inner (Min.)	Outer (Max.)
1.14	1.78	1.78	2.41	0.56	0.86

NOTES

- All dimensions are in millimetres.
- Only the underlined dimensions shall be checked during the dimension check during procurement.

FIGURE 2 - PHYSICAL DIMENSIONS

FIGURE 2.1(b) - CONNECTOR SHELLS

RECEPTACLE FEMALE CONTACTS

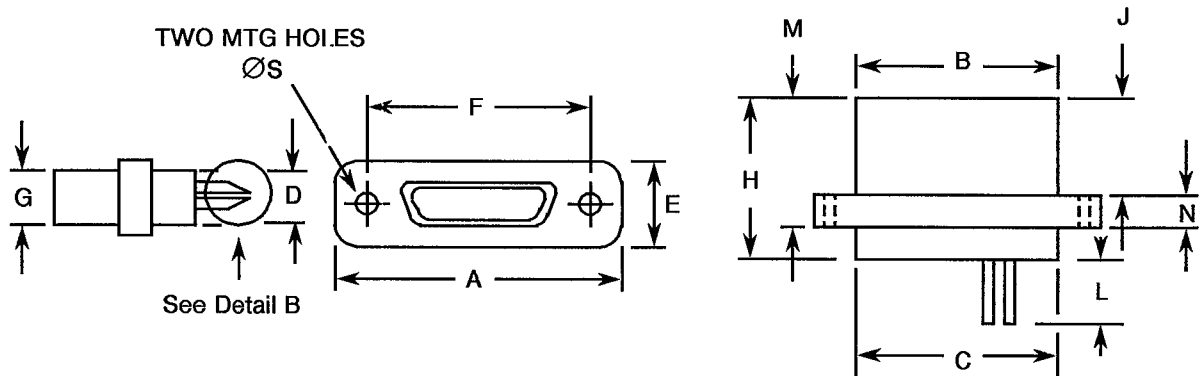

DETAIL B

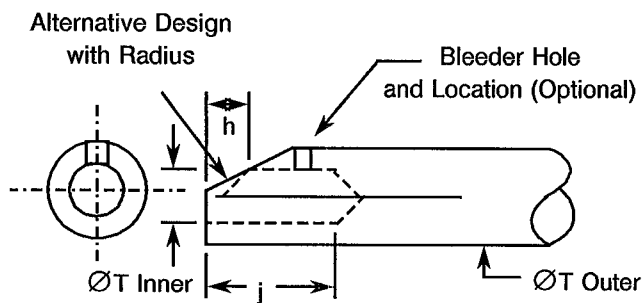

Shell Size	A Max.	B Max.	C Max.	D Max.	E Max.	E		G Max.	H Max.	J Max.	L Max.	M Max.	N		ØS	
						Min.	Max.						Min.	Max.	Min.	Max.
9	19.94	10.16	10.16	6.86	7.82	14.22	14.48	6.38	10.90	5.05	2.80	7.59	2.23	2.49	2.23	2.39
15	23.75	13.97	13.97	6.86	7.82	18.03	18.29	6.38	10.90	5.05	2.80	7.59	2.23	2.49	2.23	2.39
21	27.56	17.78	17.78	6.86	7.82	21.84	22.10	6.38	10.90	5.05	2.80	7.59	2.23	2.49	2.23	2.39
25	30.10	20.32	20.32	6.86	7.82	24.38	24.64	6.38	10.90	5.05	2.80	7.59	2.23	2.49	2.23	2.39
31	33.91	24.13	24.13	6.86	7.82	28.19	28.45	6.38	10.90	5.05	2.80	7.59	2.23	2.49	2.23	2.39
37	37.72	27.94	27.94	6.86	7.82	32.00	32.26	6.38	10.90	5.05	2.80	7.59	2.23	2.49	2.23	2.39

Dimensions for DETAIL B

h		j		ØT	
Min.	Max.	Min.	Max.	Inner (Min.)	Outer (Max.)
1.14	1.78	1.78	2.41	0.56	0.86

NOTES

1. All dimensions are in millimetres.
2. Only the underlined dimensions shall be checked during the dimension check during procurement.

FIGURE 2 - PHYSICAL DIMENSIONS

FIGURE 2.2 - CONTACT POSITION

Figure 2.2.1 - Mounting Condition

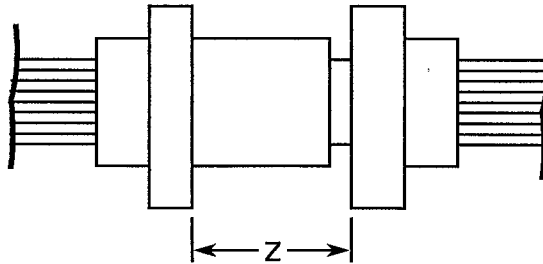

Figure 2.2.2 - Plug Male Contact

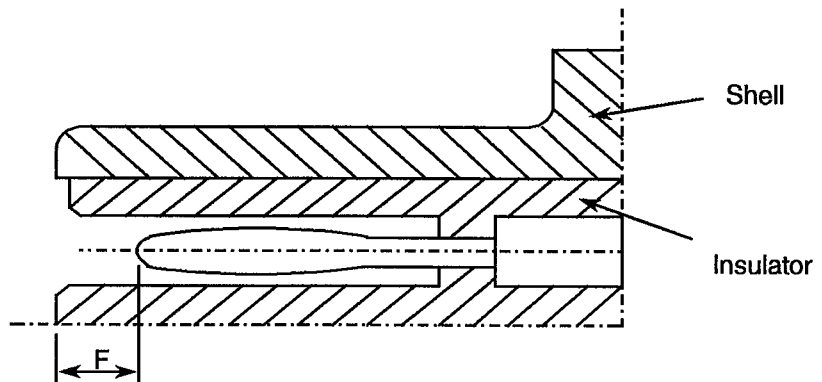
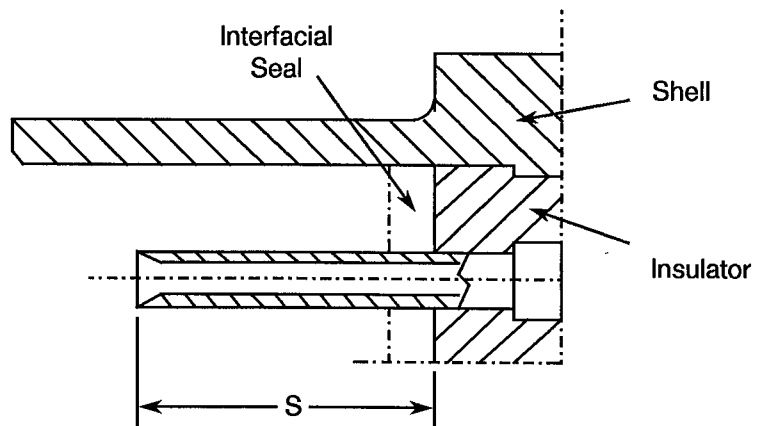

Figure 2.2.3 - Receptacle Female Contact



F		S		Z
Min.	Max.	Min.	Max.	Max.
0.25	0.91	3.30	3.66	5.49

NOTES

1. All dimensions are in millimetres.

FIGURE 2 - PHYSICAL DIMENSIONS (CONTINUED)

FIGURE 2.3 - FLOATING MOUNT

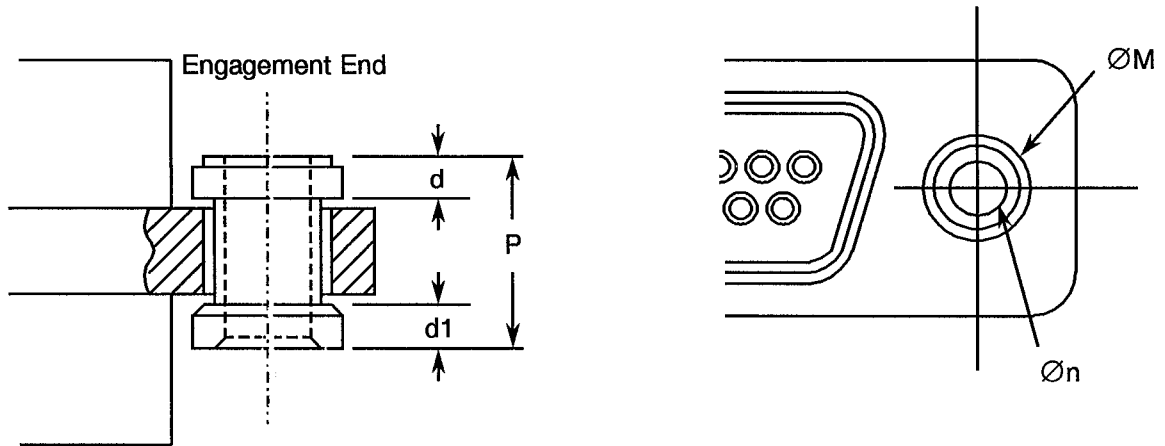

d	d1	ØM Max.	Øn Min.	P Max.
1.0	0.8	4.0	2.26	4.7

NOTES

1. All dimensions are in millimetres.
2. Total Lateral Float 0.4.
3. Total Axial Float 0.4.

FIGURE 2.4 - CAPTIVE NUT

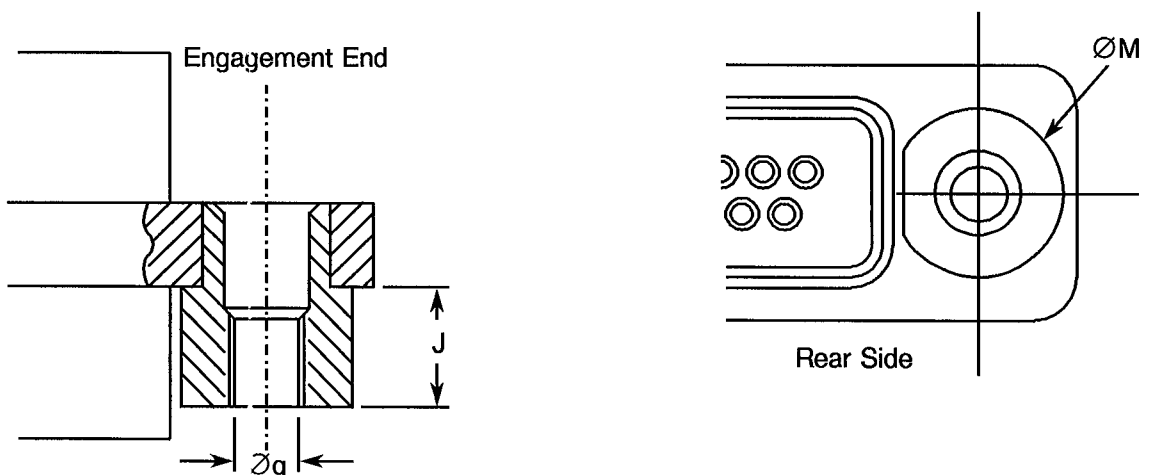

Øg	J Max.	ØM Max.
Note 2	2.60	5.1

NOTES

1. All dimensions are in millimetres.
2. Øg : 2-56 UNC 2B, Maximum Torque 0.44Nm.

FIGURE 2 - PHYSICAL DIMENSIONS (CONTINUED)

FIGURE 2.5 - EMI BACK SHELL

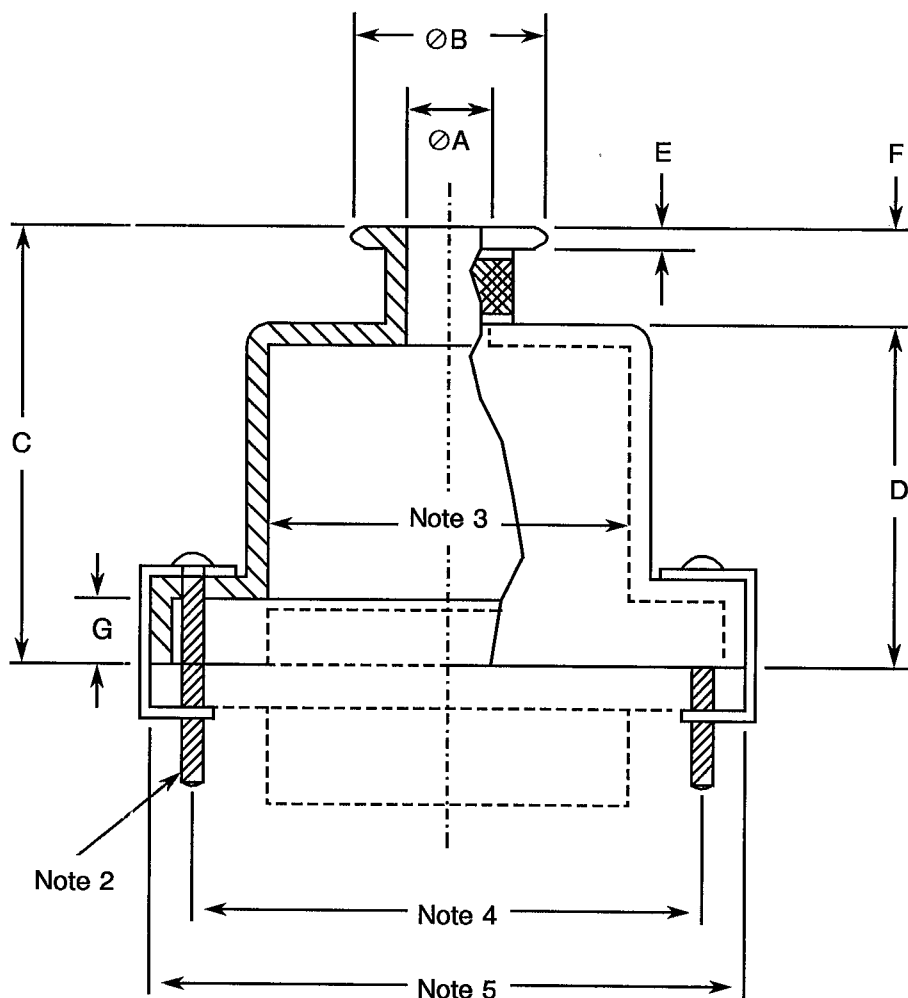

Shell Size	$\varnothing A$ Max.	$\varnothing B$ Max.	C Max.	D Max.	E Min.	F Min.	G Min.
9	7.2	11.1	20.0	8.1	1.5	11.2	4.0
15	7.2	11.1	23.2	11.2	1.5	11.2	4.0
21	7.2	11.1	26.2	14.2	1.5	11.2	4.0
25	7.2	11.1	27.7	15.7	1.5	11.2	4.0
31	7.2	11.1	29.2	17.3	1.5	11.2	4.0
37	7.2	11.1	30.3	18.3	1.5	11.2	4.0

NOTES

1. All dimensions are in millimetres.
2. 2-56 UNC 2A.
3. See Dimension C of Figure 2.1.
4. See Dimension F of Figure 2.1.
5. See Dimension A of Figure 2.1.

FIGURE 3 - CONTACT ARRANGEMENTS

FRONT VIEW OF MALE INSERT - USE MIRROR VIEW FOR FEMALE INSERT

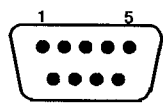

9 CONTACTS

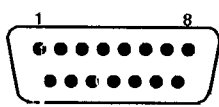

15 CONTACTS

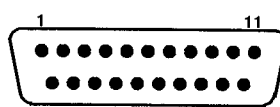

21 CONTACTS

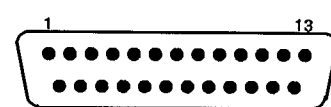

25 CONTACTS

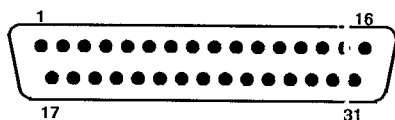

31 CONTACTS

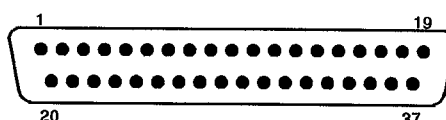

37 CONTACTS

NOTES

1. Only the outside contact cavities on each row are identified in the drawing, the remainder follow sequentially. Contact numbers are shown outside the insert for readability.

Contact Centres

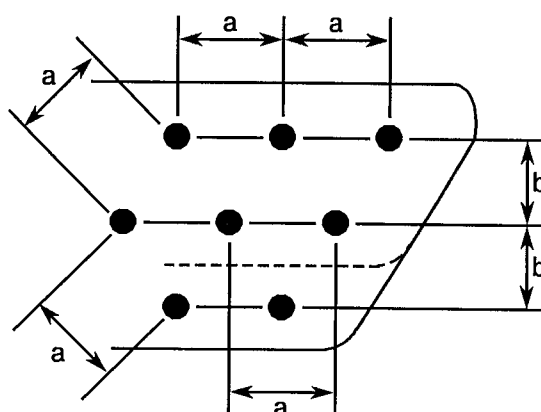

NOTES

1. a = Distance between contact centres: 1.27mm.
2. b = Distance between rows: 1.09mm.



4. REQUIREMENTS

4.1 GENERAL

The complete requirements for procurement of the connectors specified herein are stated in this specification and ESCC Generic Specification No. 3401. Deviations from the Generic Specification, applicable to this specification only, are listed in Para. 4.2.

Deviations from the applicable Generic Specification and this Detail Specification, formally agreed with specific Manufacturers on the basis that the alternative requirements are equivalent to the ESCC requirements and do not affect the components' reliability, are listed in the appendices attached to this specification.

4.2 DEVIATIONS FROM GENERIC SPECIFICATION

4.2.1 Deviations from Special In-process Controls

None.

4.2.2 Deviations from Final Production Tests (Chart II)

(a) Para. 9.4, Contact Capability: This test shall be performed on the male contacts. For details see Para. 4.3.3 of this specification.

(b) Para. 9.5, Magnetism Level: Not applicable.

4.2.3 Deviations from Burn-in and Electrical Measurements (Chart III)

None.

4.2.4 Deviations from Qualification Tests (Chart IV)

(a) Para. 9.9, Seal Test: Not applicable.

(b) Para. 9.15, Joint Strength: Not applicable.

(c) Para. 9.17, Contact Retention (In insert): Not applicable with male contact.

(d) Para. 9.27, Maintenance Ageing: Not applicable.

(e) Para. 9.29, Oversize Pin Exclusion: Not applicable.

(f) Para. 9.30, Probe Damage: Not applicable.

4.2.5 Deviations from Lot Acceptance Tests (Chart V)

(a) Para. 9.9, Seal Test: Not applicable.

(b) Para. 9.15, Joint Strength: Not applicable.

(c) Para. 9.17, Contact Retention (In insert): Not applicable with male contact.

(d) Para. 9.27, Maintenance Ageing: Not applicable.

(e) Para. 9.29, Oversize Pin Exclusion: Not applicable.

(f) Para. 9.30, Probe Damage: Not applicable.

4.3 MECHANICAL REQUIREMENTS

4.3.1 Dimension Check

The dimensions of the connectors specified herein shall be verified in accordance with the requirements set out in Para. 9.6 of ESCC Generic Specification No. 3401 and shall conform to those shown in Figure 2 of this specification.



4.3.2 Weight

The maximum weight of the connectors specified herein shall be as given in Table 1(a).

4.3.3 Contact Capability

For the purpose of this test, the pick-up and drop weights shall be as follows.

MEASUREMENTS	PICK-UP WEIGHT	DROP WEIGHT
Weight (g)	14	170
Inner Gauge Diameter (mm) (1)	0.582 - 0.587	0.559 - 0.564
Insertion Depth (mm)	1.5	1.5

NOTES

1. See Figure 4 for ØA.

4.3.4 Contact Retention (In insert)

Contact retention within the insert shall be 22.25 Newtons. There shall be no displacement of the contact.

4.3.5 Mating and Unmating Forces

The forces applied for the mating and unmating of the connectors shall conform to the values specified in Table 1(a).

4.3.6 Insert Retention (In shell)

Connector inserts shall withstand a pressure of 34.4N/cm² applied from the mating side to the rear side.

4.3.7 Jackscrew Retention

Not applicable.

4.3.8 Contact Insertion and Withdrawal Forces

Not applicable.

4.3.9 Engagement and Separation Forces (Male Contacts)

The contact engagement and separation forces of the male contacts shall be tested to a depth of 1.5mm with the applicable test gauge fixtures specified in Figure 4 of this specification, and shall not exceed the values of the table hereunder.

MEASUREMENTS	INNER DIAMETER (mm)		ENGAGEMENT FORCE Max. (N)	SEPARATION FORCE Min. (N)
	Min.	Max.		
Max. Gauge Fixture	0.559	0.564	1.667	-
Min. Gauge Fixture	0.582	0.587	-	0.137

4.3.10 Oversize Pin Exclusion

Not applicable.

4.3.11 Probe Damage

Not applicable.



4.3.12 Solderability

Size A soldering iron shall be used.

4.4 MATERIALS AND FINISHES

The materials and finishes shall be as specified herein. Where a definite material is not specified, a material which will enable the connectors specified herein to meet the performance requirements of this specification shall be used. Acceptance or approval of any constituent material does not guarantee acceptance of the finished product.

4.4.1 Shells

Shells shall be made of aluminium alloy plated with a minimum thickness of 25.4µm of electroless nickel.

4.4.2 Inserts

Inserts shall be made of glass fibre-filled diallylphthalate resin or suitable thermoplastic material.

4.4.3 Contacts

4.4.3.1 Female Contacts

The contact body shall be made of copper alloy with an underplate of 1.0µm minimum of copper, gold plated with 1.27µm minimum of gold, Type 2, Grade C of MIL-G-45204. Measurement of thickness shall be performed at a distance of 1.5mm from the engagement end.

4.4.3.2 Male Contacts

The contact body and the bundle shall be made of copper alloy with an underplate of 1.0µm minimum of copper, gold plated with 1.27µm minimum of gold, Type 2, Grade C of MIL-G-45204. Measurement of thickness shall be performed at a distance of 1.5mm from the engagement end.

4.4.4 Seals Interfacial

Interfacial seals shall be made of silicon base rubber.

4.4.5 Rear Potting

Rear potting shall be made of epoxy resin.

4.4.6 EMI Backshell

EMI Backshell shall be made of aluminium alloy plated with a minimum thickness of 25.4µm of electroless nickel.

4.5 MARKING

4.5.1 General

The marking of all components delivered to this specification shall be in accordance with the requirements of ESCC Basic Specification No. 21700 and the following paragraphs. When the component is too small to accommodate all of the marking specified, as much as space permits shall be marked and the marking information, in full, shall accompany the component in its primary package.

The information to be marked and the order of precedence shall be as follows:-

- (a) The ESCC Component Number.
- (b) Characteristics.



(c) Traceability Information.

4.5.2 The ESCC Component Number

Each component shall bear the ESCC Component Number which shall be constituted and marked as follows:-

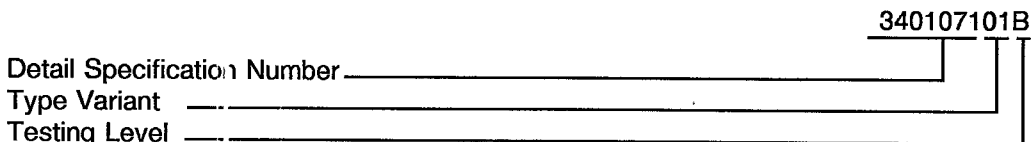

N.B.

Marking of the Type Variant is mandatory. No further reference to type variant is made in this specification.

4.5.3 Characteristics

The characteristics to be marked in the following order of precedence are:-

- (a) Shell Size.
- (b) Contact Type.
- (c) Termination Type.
- (d) Floating Mount or Captive Nut.

The information shall be constituted and marked as follows:-

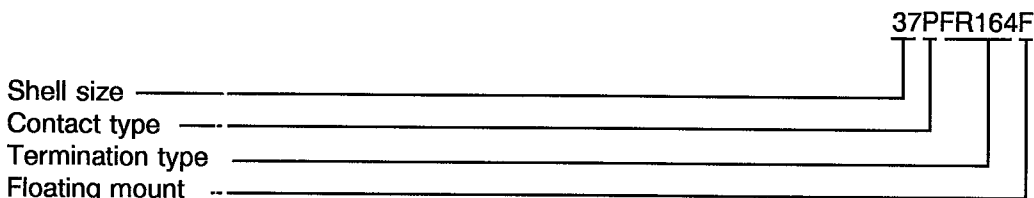

4.5.3.1 Shell Size

Shell size shall be designated by the number of contacts.

Specified numbers are: 9, 15, 21, 25, 31 and 37.

4.5.3.2 Contact Type

Contact types shall be indicated by the following code letters.

Code Letter	Contact Type
P	Male
S	Female

4.5.3.3 Termination Type

Termination code FR164 defines the solder bucket termination, according to Figure 2.1.

4.5.3.4 Fixing Option

The letter "F" shall indicate a floating mount. The letter "E" shall indicate a captive nut. If the shell has standard mounting holes, the letter shall be omitted.

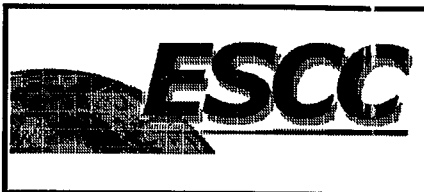

4.5.4 Traceability Information

Traceability information shall be marked in accordance with the requirements of ESCC Basic Specification No. 21700.

4.6 ELECTRICAL MEASUREMENTS

4.6.1 Electrical Measurements at Room Temperature

The parameters to be measured in respect of electrical characteristics are scheduled in Table 2. Unless otherwise specified, the measurements shall be performed at $T_{amb} = +22 \pm 3 \text{ }^\circ\text{C}$.

4.6.2 Electrical Measurements at High and Low Temperatures

Not applicable.

4.6.3 Circuits for Electrical Measurements

Not applicable.

4.7 BURN-IN AND ELECTRICAL MEASUREMENTS (TABLES 4 AND 5)

Not applicable.

TABLE 2 - ELECTRICAL MEASUREMENTS AT ROOM TEMPERATURE

No.	Characteristic	Symbol	ESCC 3401 Test Method	Test Condition	Limits		Unit
					Min.	Max.	
1	Insulation Resistance	Ri	Para. 9.1.1.1	Para. 9.1.1.1	5000	-	MΩ
2	Voltage Proof Leakage Current	I _L	Para. 9.1.1.2	600 Vrms	-	2.0	mA
3	Mated Shell Conductivity (Voltage Drop) (1)	Vd	Para. 9.1.1.4	Para. 9.1.1.4	Not applicable		mV
4	Contact Resistance (Low Level Current)	Rcl max.	Para. 9.1.1.3	Para. 9.1.1.3	-	6.0	mΩ
5	Contact Resistance (Rated Current)	Rcr max.	Para. 9.1.1.3	3.0A	-	5.0	mΩ

NOTES

1. Applicable to mated connectors with grounding option.

TABLES 3, 4 AND 5

Not applicable.

FIGURE 4 - GAUGE FIXTURE

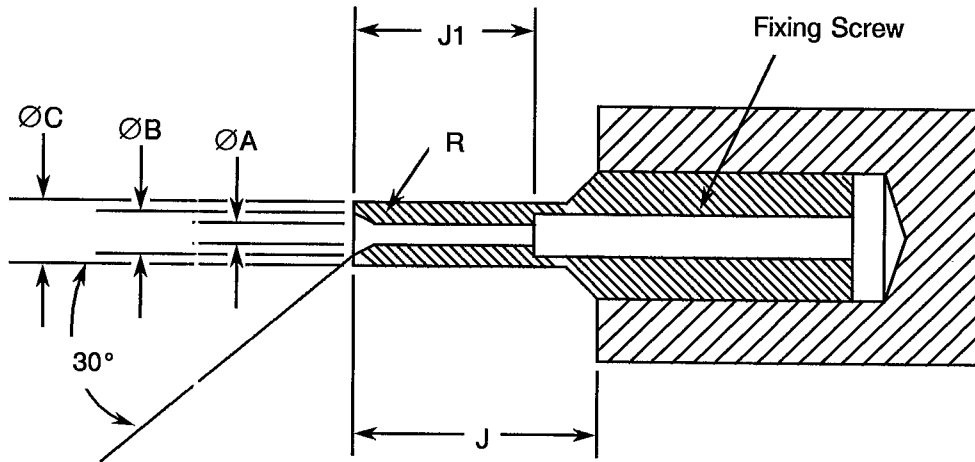

MAXIMUM GAUGE

WEIGHT (g) 170			REMARKS
	MIN.	MAX.	
ØA	0.559	0.564	-
ØB	0.749	0.775	-
ØC	0.813	0.825	-
J	4.0	-	-
J1	3.13	3.23	-
R	0.381	0.483	Note 1

MINIMUM GAUGE

WEIGHT (g) 14			REMARKS
	MIN.	MAX.	
ØA	0.582	0.587	-
ØB	0.749	0.775	-
ØC	0.813	0.825	-
J	4.0	-	-
J1	3.13	3.23	-
R	0.381	0.483	Note 1

NOTES

1. Radius 'R', must be tangent to entry chamfer and ØA.
2. ØA and entry chamfer must be polished to $\frac{N8}{\sqrt{\quad}}$.

	<p style="text-align: center;">ESCC Detail Specification No. 3401/071</p>	<p style="text-align: right;">PAGE 20 ISSUE 1</p>
---	---	---

4.8 ENVIRONMENTAL AND ENDURANCE TESTS (CHARTS IV AND V OF ESCC GENERIC SPECIFICATION NO. 3401)

4.8.1 Measurements and Inspections on Completion of Environmental Tests

The parameters to be measured and inspections to be performed on completion of environmental testing shall be those specified in Table 6. Unless otherwise specified, these measurements shall be performed at $T_{amb} = +22 \pm 3 \text{ }^\circ\text{C}$.

4.8.2 Measurements and Inspections at Intermediate Points during Endurance Tests

Not applicable.

4.8.3 Measurement and Inspections on Completion of Endurance Tests

The parameters to be measured and inspections to be performed on completion of endurance testing shall be those specified in Table 6. Unless otherwise specified, these measurements shall be performed at $T_{amb} = +22 \pm 3 \text{ }^\circ\text{C}$.

4.8.4 Conditions for Operating Life Test (Part of Endurance Testing)

Not applicable.

4.8.5 Electrical Circuit for Operating Life Test

Not applicable.

4.8.6 Conditions for High Temperature Storage Test (Part of Endurance Testing)

The requirements for the high temperature storage test are specified in Section 9 of ESCC Generic Specification No. 3401. The temperature to be applied shall be the maximum storage temperature specified in Table 1(b) of this specification.

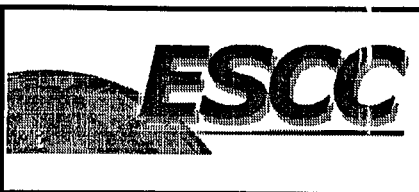

TABLE 6 - MEASUREMENTS AND INSPECTIONS ON COMPLETION OF ENVIRONMENTAL AND ENDURANCE TESTING

No.	ESCC GENERIC SPEC. NO. 3401		MEASUREMENTS AND INSPECTIONS		SYMBOL	LIMITS		UNIT
	ENVIRONMENTAL AND ENDURANCE TESTS (1)	TEST METHOD AND CONDITIONS	IDENTIFICATION	CONDITIONS		MIN.	MAX.	
01	Seal Test	Para. 9.9	ESCC 3401 Para. 9.9	-	-	Not applicable		-
02	Wiring	Para. 9.10 and Table 1(a) of this spec.	Low Level Contact Resistance	Table 2 Item 4	Rcl	-	-	-
03	Vibration	Para. 9.11	Initial Measurements Coupling screw(s) Unlocking Torque Final Measurements Full Engagement Coupling screw(s) Unlocking Torque Drift Visual Examination	-	-	Record Values		-
04	Shock or Bump	Para. 9.12	Full Engagement Visual Examination	-	-	-	-	-
05	Climatic Sequence	Para. 9.13	Dry Heat Insulation Resistance Low Air Pressure Voltage Proof Leakage Current Damp Heat Insulation Resistance Final Measurements External Visual Inspection Insulation Resistance Voltage Proof Leakage Current	At High Temperature Table 2, Item 1 Figure 1 Immediately after test Table 2, Item 1 After 1-24 hrs Recovery ESCC 3401 Para. 9.7 Table 2, Item 1 Table 2, Item 2	Ri I _L Ri Ri I _L	10 ESCC 3401 9.13.5 100 ESCC 3401 Para. 9.7 Table 2, Item 1 Table 2, Item 2	- - - -	MΩ MΩ
06	Plating Thickness	Para. 9.14	Thickness	-	-	Para. 4.4.3 of this spec.		-
07	Joint Strength (N/A to solder contacts)	Para. 9.15	ESCC 3401 Para. 9.15	-	-	Not applicable		-
08	Rapid Change of Temperature	Para. 9.16	Visual Examination Insulation Resistance Voltage Proof Leakage Current	- Table 2, Item 1 Table 2, Item 2	- Ri I _L	- Table 2, Item 1 Table 2, Item 2	- -	-
09	Contact Retention (In Insert)	Para. 9.17 & Para. 4.3.4 of this spec.	Contact Displacement	-	-	ESCC 3401 Para. 9.17		-
10	Endurance	Para. 9.18	Initial Measurements Mating/Unmating Forces Low Level Contact Resistance Mated Shell Conductivity Final Measurements Visual Examination Mating/Unmating Forces Low Level Contact Drift Resistance Mated Shell Conductivity Insulation Resistance Voltage Proof Leakage Current	 Table 2, Item 4 Table 2, Item 3 Table 2, Item 4 Table 2, Item 5 Table 2, Item 3 Table 2, Item 1 Table 2, Item 2	F Rcl Vd - F ΔRcl Vd Ri I _L	Para. 4.3.5 of this spec. Record Values Not applicable Para. 4.3.5 of this spec. - 3.0 Not applicable Table 2, Item 1 Table 2, Item 2	- -	- mΩ

NOTES

1. The tests in this table refer to either Chart IV or V and shall be used as applicable.

