



Pages 1 to 21

**RF COAXIAL ADAPTORS  
AND CONNECTING PIECES,  
TYPE SMA 2.9, 50 OHMS**

**ESCC Detail Specification No. 3402/023**

**ISSUE 1  
July 2003**



Document Custodian: European Space Agency - see <https://escies.org>

	ESCC Detail Specification No. 3402/023		PAGE i ISSUE 1
---	---	--	-------------------

#### **LEGAL DISCLAIMER AND COPYRIGHT**

European Space Agency, Copyright © 2003. All rights reserved.

The European Space Agency disclaims any liability or responsibility, to any person or entity, with respect to any loss or damage caused, or alleged to be caused, directly or indirectly by the use and application of this ESCC publication.

This publication, without the prior permission of the European Space Agency and provided that it is not used for a commercial purpose, may be:

- copied in whole in any medium without alteration or modification.
- copied in part, in any medium, provided that the ESCC document identification, comprising the ESCC symbol, document number and document issue, is removed.

**DOCUMENTATION CHANGE NOTICE**

(Refer to <https://escies.org> for ESCC DCR content)

DCR No.	CHANGE DESCRIPTION

**TABLE OF CONTENTS**

	<u>Page</u>
<b>1. <u>GENERAL</u></b>	<b>5</b>
1.1 Scope	5
1.2 Type Variants	5
1.3 Maximum Ratings	5
1.4 Parameter Derating Information	5
1.5 Physical Dimensions	5
1.6 Standard Test Connector Interface	5
<b>2. <u>APPLICABLE DOCUMENTS</u></b>	<b>11</b>
<b>3. <u>TERMS, DEFINITIONS, ABBREVIATIONS, SYMBOLS AND UNITS</u></b>	<b>11</b>
<b>4. <u>REQUIREMENTS</u></b>	<b>11</b>
4.1 General	11
4.2 Deviations from Generic Specification	11
4.2.1 Deviations from Special In-process Controls	11
4.2.2 Deviations from Final Production Tests	11
4.2.3 Deviations from Burn-in Tests	11
4.2.4 Deviations from Qualification Tests	11
4.2.5 Deviations from Lot Acceptance Tests	11
4.3 Mechanical Requirements	12
4.3.1 Dimension Check	12
4.3.2 Weight	12
4.3.3 Coupling Proof Torque	12
4.3.4 Cable Retention Force	12
4.3.5 Mating and Unmating Forces	12
4.3.6 Endurance	12
4.3.7 Residual Magnetism	12
4.3.8 Contact Engagement and Separation Forces	13
4.3.9 Contact Retention	13
4.4 Materials and Finishes	13
4.4.1 Passivated Amagnetic Stainless Steel Connector	14
4.5 Marking	14
4.5.1 General	14
4.5.2 The ESCC Component Number	14
4.5.3 Characteristics	15
4.5.4 Traceability Information	15
4.5.5 Marking of Small Components	15
4.6 Electrical Measurements	15
4.6.1 Electrical Measurements at Room Temperature	15
4.6.2 Electrical Measurements at High and Low Temperatures	15
4.6.3 Circuits for Electrical Measurements	15
4.7 Burn-in Tests	15
4.8 Environmental and Endurance Tests	16
4.8.1 Measurements and Inspections on Completion of Environmental Tests	16
4.8.2 Measurements and Inspections at Intermediate Points during Endurance Tests	16
4.8.3 Measurements and Inspections on Completion of Endurance Tests	16
4.8.4 Conditions for Operating Life Test	16
4.8.5 Electrical Circuits for Operating Life Test	16
4.8.6 Conditions for High Temperature Storage Test	16



<b><u>TABLES</u></b>		<b><u>Page</u></b>
1(a)	Type Variants	6
1(b)	Maximum Ratings	6
2	Electrical Measurements at Room Temperature	16
3	Not applicable	N/A
4	Not applicable	N/A
5	Not applicable	N/A
6	Measurements and Inspections on Completion of Environmental and Endurance Tests	17

<b><u>FIGURES</u></b>		
1	Parameter Derating Information	7
2	Physical Dimensions	8
2(a)	Connector Interface - Male Contact and Female Contact	8
2(b)	Variants	19
3	Standard Test Connector Interface - Male Contact and Female Contact	10
4	Test Pin Configuration	13

**APPENDICES (Applicable to specific Manufacturers only)**

None.



1. GENERAL

1.1 SCOPE

This specification details the ratings, physical and electrical characteristics, test and inspection data for RF coaxial adaptors and connecting pieces, Type SMA 2.9, 50 Ohms. It shall be read in conjunction with ESCC Generic Specification No. 3402, the requirements of which are supplemented herein.

1.2 TYPE VARIANTS

A list of the type variants of the connectors specified herein, which are also covered by this specification, is given in Table 1(a).

For each type variant, the full electrical and physical characteristics are given in individual Figures 2(b) at the end of this specification.

1.3 MAXIMUM RATINGS

The maximum ratings, which shall not be exceeded at any time during use or storage, applicable to the connectors specified herein, are as scheduled in Table 1(b).

1.4 PARAMETER DERATING INFORMATION (FIGURE 1)

The derating information applicable to the connectors specified herein is shown in Figure 1.

1.5 PHYSICAL DIMENSIONS

The physical dimensions of the connectors specified herein are shown in Figures 2(a) and 2(b).

1.6 STANDARD TEST CONNECTOR INTERFACE

Whenever gauges are required for mating with the connectors under test, their physical dimensions shall be in accordance with those specified in Figure 3.

**TABLE 1(a) - TYPE VARIANTS**

VARIANT	DESCRIPTION
01	Straight Male-Male Adaptor
02	Straight Female-Female Adaptor
03	Straight Male-Female Adaptor

**NOTES:**

- Each variant is detailed in Figure 2(b).

**TABLE 1(b) - MAXIMUM RATINGS**

No.	CHARACTERISTICS	SYMBOL	MAXIMUM RATINGS	UNIT	REMARKS
1	Power	P	See Figures 1(a) and 1(b)	W	For information
2	Nominal Impedance	Z	50	$\Omega$	-
3	Frequency Range	f	See Figure 2(b)	GHz	-
4	Dielectric Withstanding Voltage at ambient pressure	$V_{dw}$	See Figure 2(b)	Vrms	Voltage Proof test. At sea level
5	Dielectric Withstanding Voltage at low pressure	$V_{lp}$	10% of $V_{dw}$	Vrms	At 44mb
6	Rated Operating Voltage	$V_{op}$	50% of $V_{dw}$	Vrms	-
7	Corona Level	$V_{co}$	8.5% of $V_{dw}$	Vrms	-
8	Operating Temperature Range	$T_{op}$	See Figure 2(b)	$^{\circ}C$	-
9	Storage Temperature Range	$T_{stg}$	As per Operating Temperature Range	$^{\circ}C$	-

**FIGURE 1 - PARAMETER DERATING INFORMATION**

FIGURE 1(a) - POWER VERSUS FREQUENCY

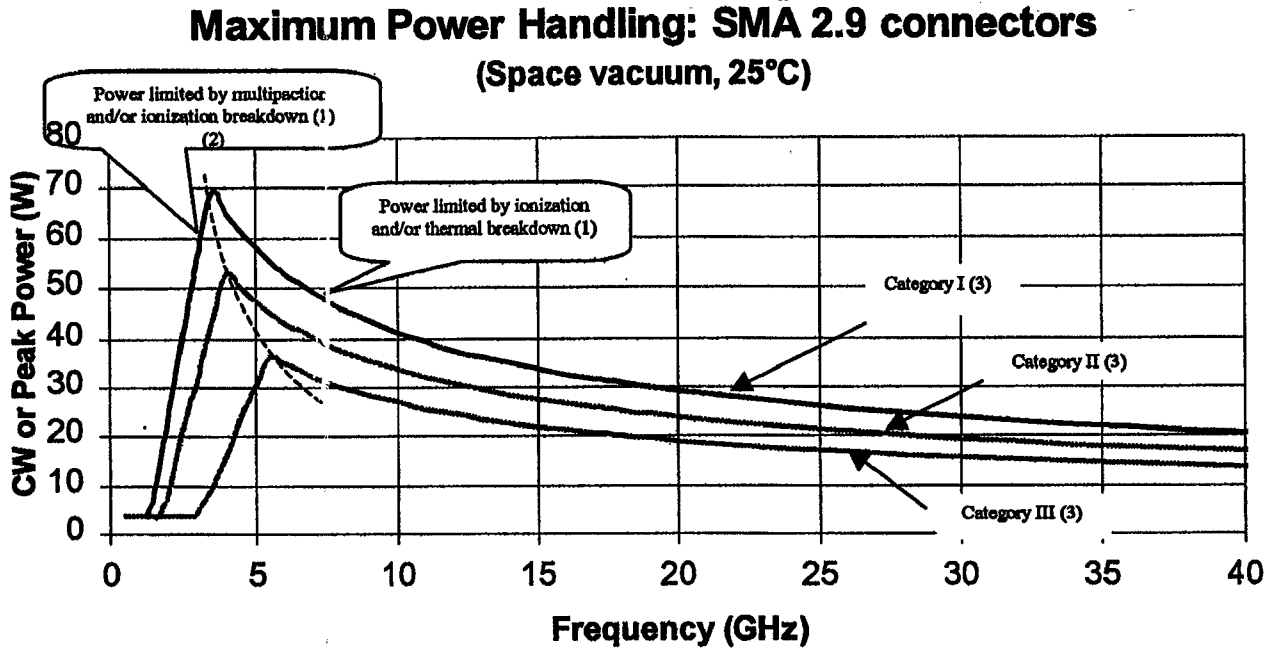

**NOTES:**

1. Load VSWR is better than 1.30:1.
2. The part of the curve limited by multipactor takes into account a 6dB margin.
3. See Figure 2(b) to know applicability of power handling categories to the different variants.

FIGURE 1(b) - POWER VERSUS OPERATING TEMPERATURE

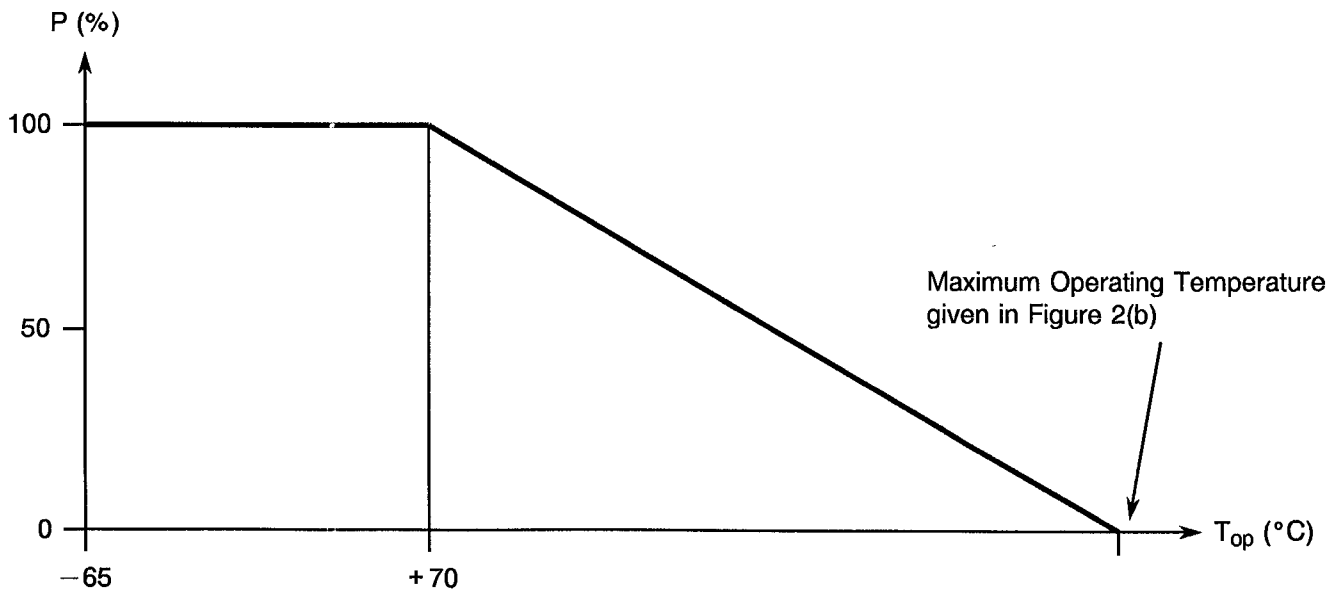



**FIGURE 2 - PHYSICAL DIMENSIONS**

**FIGURE 2(a) - CONNECTOR INTERFACE - FEMALE CONTACT**

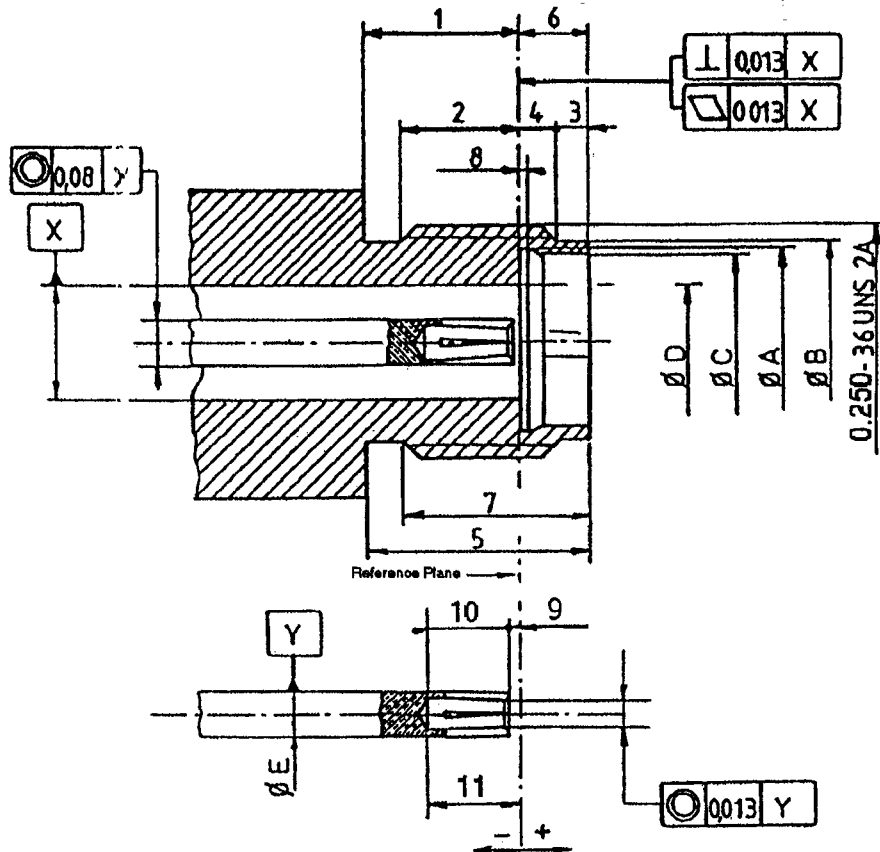

SYMBOL	MILLIMETRES		NOTES
	MIN.	MAX.	
1	3.82	4.32	
2	2.87	3.27	
3	0.65	0.95	
4	0.93	1.33	
5	5.8	6.2	
6	1.88	1.98	
7	4.85	5.15	
8	0.3	0.5	
9	0.0	0.08	
10	2.4	2.6	
11	2.4	2.68	
ØA	4.8	5.0	
ØB	5.3	5.35	
ØC	4.6	4.63	
ØD	2.905	2.945	
ØE	1.26	1.28	

**FIGURE 2 - PHYSICAL DIMENSIONS**

FIGURE 2(a) (CONTINUED) - CONNECTOR INTERFACE - MALE CONTACT

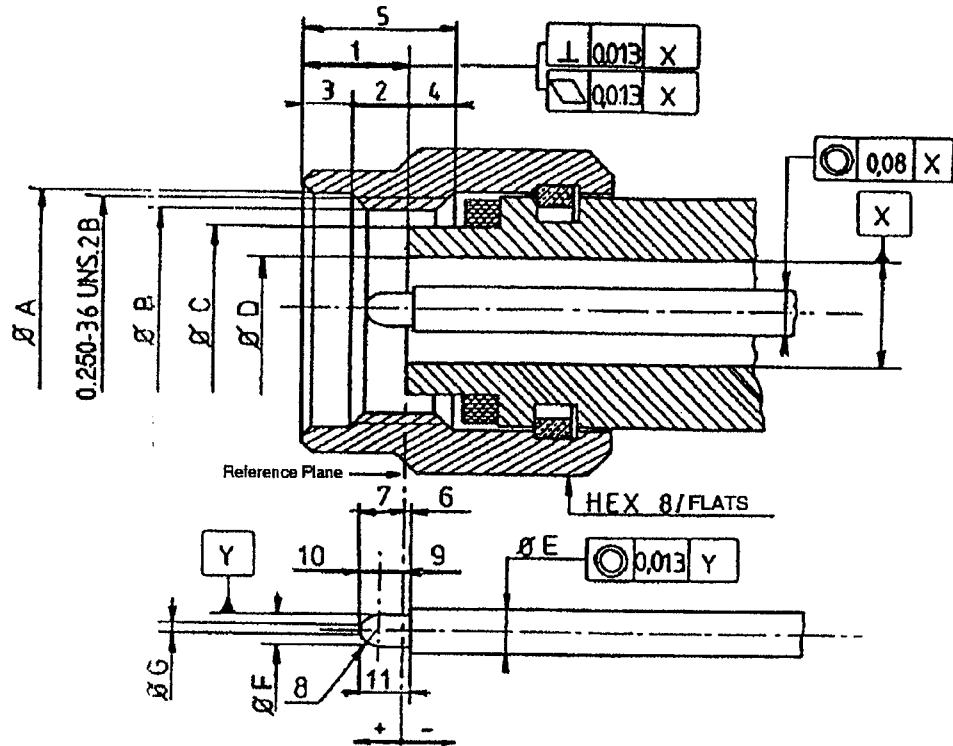

SYMBOL	MILLIMETRES		NOTES
	MIN.	MAX.	
1	2.63	3.25	Radius
2	1.58	2.2	
3	0.75	1.15	
4	0.85	1.47	
5	3.8	4.2	
6	0.0	0.08	
7	1.22	1.4	
8	R 0.8	R 0.9	
9	0.493	0.784	
10	0.616	0.727	
11	1.3	1.4	
ØA	6.6	6.7	
ØB	5.59	-	
ØC	4.55	4.58	
ØD	2.905	2.94	
ØE	1.26	1.28	
ØF	0.92	0.94	
ØG	0.2	0.34	



ESCC Detail Specification  
No. 3402/023

PAGE 10

ISSUE 1

**FIGURE 3 - STANDARD TEST CONNECTOR INTERFACE - MALE CONTACT AND FEMALE CONTACT**

SEE FIGURE 2(a)



## 2. APPLICABLE DOCUMENTS

The following documents form part of this specification and shall be read in conjunction with it:-

- (a) ESCC Generic Specification No. 3402 for RF Coaxial Connectors.
- (b) MIL-G-45204, Gold Plating, Electrodeposited.

## 3. TERMS, DEFINITIONS, ABBREVIATIONS, SYMBOLS AND UNITS

For the purpose of this specification, the terms, definitions, abbreviations, symbols and units specified in ESCC Basic Specification No. 21300 shall apply.

In addition the following shall apply:-

- $V_{dw}$  Dielectric Withstanding Voltage at ambient pressure (sea level)
- $V_{lp}$  Dielectric Withstanding Voltage at low pressure (44mb)
- $V_{co}$  Corona Level Voltage
- $R_i$  Insulation Resistance
- $I_L$  Leakage Current.

## 4. REQUIREMENTS

### 4.1 GENERAL

The complete requirements for procurement of the connectors specified herein are stated in this specification and ESCC Generic Specification No. 3402. Deviations from the Generic Specification applicable to this specification only, are listed in Para. 4.2.

Deviations from the applicable Generic Specification and this Detail Specification, formally agreed with specific Manufacturers on the basis that the alternative requirements are equivalent to the ESCC requirements and do not affect the components' reliability, are listed in the appendices attached to this specification.

### 4.2 DEVIATIONS FROM GENERIC SPECIFICATION

#### 4.2.1 Deviations from Special In-process Controls

None.

#### 4.2.2 Deviations from Final Production Tests (Chart II)

None.

#### 4.2.3 Deviations from Burn-in Tests (Chart III)

Not applicable.

#### 4.2.4 Deviations from Qualification Tests (Chart IV)

None.

#### 4.2.5 Deviations from Lot Acceptance Tests (Chart V)

None.

	<p style="text-align: center;">ESCC Detail Specification No. 3402/023</p>	<p style="text-align: right;">PAGE 12 ISSUE 1</p>
---	---	---

4.3 MECHANICAL REQUIREMENTS

4.3.1 Dimension Check

The dimensions of the connectors specified herein shall be verified in accordance with the requirements set out in Para. 9.25 of ESCC Generic Specification No. 3402 and shall conform to those shown in Figures 2(a) and 2(b) of this specification.

4.3.2 Weight

The maximum weight of the connectors specified herein shall be as specified in Figure 2(b).

4.3.3 Coupling Proof Torque

The requirements for testing of the coupling proof torque are specified in Section 9 of ESCC Generic Specification No. 3402. The applied torque shall be 170N.cm.

4.3.4 Cable Retention Force

Not applicable.

4.3.5 Mating and Unmating Forces

The applicable measurement requirements are specified in Section 9 of ESCC Generic Specification No. 3402. The maximum torque during mating and unmating shall not exceed 23N.cm.

Whenever a test is performed on mated pairs of connectors, the pairs shall be torqued at 80-115N.cm.

4.3.6 Endurance

The applicable test requirements are specified in Section 9 of ESCC Generic Specification No. 3402. The test conditions shall be as follows:-

- (a) Number of cycles : 500 for qualification; 100 for lot acceptance.
- (b) Rate : 12 cycles maximum/minute.

4.3.7 Residual Magnetism

The applicable measurement requirements are specified in Section 9 of ESCC Generic Specification No. 3402. Residual magnetism is not applicable to stainless steel connectors.

#### 4.3.8 Contact Engagement and Separation Forces

The requirements for these measurements are specified in Section 9 of ESCC Generic Specification No. 3402 and apply to female contacts only.

##### (a) Oversize Pin

Steel test pin diameter : 0.95/0.955 mm.  
Insertion depth : 0.76/1.14 mm.  
Number of insertions : 3.

##### (b) Engagement Force Test (Maximum Diameter Test Pin)

Steel test pin diameter : 0.94/0.946 mm.  
Engagement depth : 1.27/1.9 mm.  
Engagement force : 1380g max.

##### (c) Separation Force Test (Minimum Diameter Test Pin)

Steel test pin diameter : 0.89/0.902 mm.  
Separation depth : 1.27/1.9 mm.  
Separation force : 28g min.

**FIGURE 4 - TEST PIN CONFIGURATION**

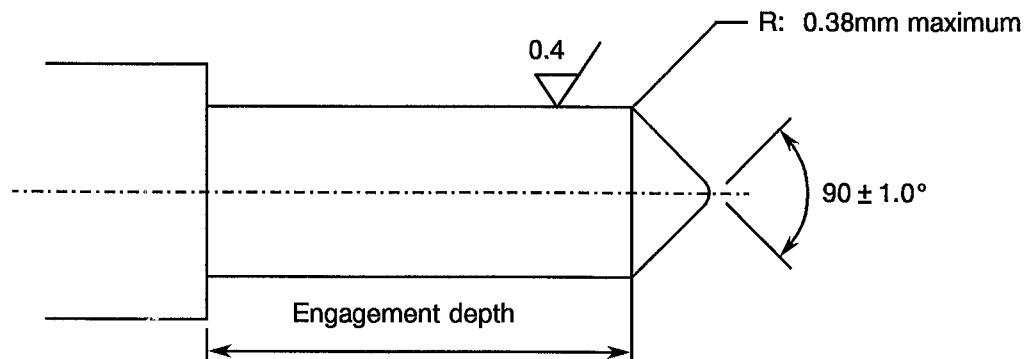

#### 4.3.9 Contact Retention

The requirements for this test are specified in Section 9 of ESCC Generic Specification No. 3402. The test conditions are given in Figure 2(b). After testing, the connector interface dimensions shall be within the limits of Figure 2(a).

#### 4.4 MATERIALS AND FINISHES

The materials and finishes shall be as specified herein. Where a definite material is not specified, a material which will enable the connectors specified herein to meet the performance requirements of this specification shall be used. Acceptance or approval of any constituent material does not guarantee acceptance of the finished product.



4.5.3 Characteristics

Characteristics cover the type of plating/material. Each component shall be marked in respect of:-

- (a) Type of plating/material (shell).
- (b) Number.

The information shall be constituted as follows:

Type of plating/material (see Para. 4.5.3.1) \_\_\_\_\_ 3 01  
 Number (shall always be 01) \_\_\_\_\_

4.5.3.1 Type of Plating/Material

The type of plating material shall be identified by means of the following code:-

CODE	TYPE OF PLATING/MATERIAL	PARA.
3	Passivated amagnetic stainless steel	4.4.1

**NOTE:** Codes 1, 2 and 4 are not used.

4.5.4 Traceability Information

Each component shall be marked in respect of traceability information in accordance with the requirements of ESCC Basic Specification No. 21700.

4.5.5 Marking of Small Components

When it is considered that the component is too small to accommodate the marking as specified above, as much as space permits shall be marked. The order of precedence shall be as specified in Para. 4.5.1. The marking information in full shall accompany each component in its primary package.

4.6 ELECTRICAL MEASUREMENTS

4.6.1 Electrical Measurements at Room Temperature

The parameters to be measured in respect of electrical characteristics are scheduled in Table 2. Unless otherwise specified, the measurements shall be performed at  $T_{amb} = +22 \pm 3$  °C.

4.6.2 Electrical Measurements at High and Low Temperatures (Table 3)

Not applicable.

4.6.3 Circuits for Electrical Measurements

Not applicable.

4.7 BURN-IN TESTS (TABLES 4 AND 5)

Not applicable.



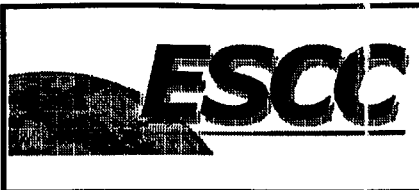

**TABLE 2 - ELECTRICAL MEASUREMENTS AT ROOM TEMPERATURE**

No.	CHARACTERISTICS	SYMBOL	SPEC. AND/OR TEST METHOD	TEST CONDITIONS	LIMITS		UNIT
					MIN	MAX	
1	Insulation Resistance	$R_i$	ESCC 3402, Para. 9.1	500 Vdc	5000	-	$M\Omega$
2	Leakage Current	$I_L$	ESCC 3402, Para. 9.2	Per Voltage Proof test voltage in Figure 2(b)	-	2.0	mA

**TABLES 3, 4 AND 5**

Not applicable.

**4.8 ENVIRONMENTAL AND ENDURANCE TESTS (CHARTS IV AND V OF ESCC GENERIC SPECIFICATION No. 3402)**

**4.8.1 Measurements and Inspections on Completion of Environmental Tests**

The parameters to be measured on completion of environmental tests are scheduled in Table 6 of this specification. Unless otherwise stated, the measurements shall be performed at  $T_{amb} = +22 \pm 3$  °C.

**4.8.2 Measurements and Inspections at Intermediate Points during Endurance Tests**

Not applicable.

**4.8.3 Measurements and Inspections on Completion of Endurance Tests**

The parameters to be measured on completion of endurance tests are scheduled in Table 6 of this specification. Unless otherwise stated, the measurements shall be performed at  $T_{amb} = +22 \pm 3$  °C.

**4.8.4 Conditions for Operating Life Test (Part of Endurance Testing)**

Not applicable.

**4.8.5 Electrical Circuits for Operating Life Test**

Not applicable.

**4.8.6 Conditions for High Temperature Storage Test (Part of Endurance Testing)**

The requirements for the high temperature storage test are specified in Section 9 of ESCC Generic Specification No. 3402. The conditions for high temperature storage shall be the maximum operating temperature as specified in Figure 2(b).



**TABLE 6 - MEASUREMENTS AND INSPECTIONS ON COMPLETION OF ENVIRONMENTAL AND ENDURANCE TESTS**

NO.	ESCC GENERIC SPEC. NO. 3402		MEASUREMENTS AND INSPECTIONS		SYMBOL	LIMITS		UNIT
	ENVIRONMENTAL AND ENDURANCE TESTS (1)	TEST METHOD AND CONDITIONS	IDENTIFICATION	CONDITIONS		MIN.	MAX.	
01	Coupling Proof Torque	Para. 9.4	<b>Final Measurements</b> Interface Dimensions Visual Examination	- Para. 9.4 of ESCC 3402	- -	Figure 2(a) -		- -
02	Mating and Unmating Forces	Para. 9.5	<b>During Test</b> Torque	Para. 4.3.5 of this spec.	-	-	23	N.cm
03	Seal Test	Para. 9.7	Hermeticity Leakage	Not applicable As applicable	- -	-	- No Bubbles	- -
04	External Visual Inspection	Para. 9.8	External Visual Inspection	Para. 9.8 of ESCC 3402	-	-	-	-
05	Contact Resistance	Para. 9.9	<b>During Test</b> Contact Resistance	Para. 9.9 of ESCC 3402 Centre Contact Shell	- -	-	3.0 2.0	mΩ mΩ
06	Vibration	Para. 9.10 Full Engagement	<b>During Test</b>  <b>Electrical Measurements</b> <b>Final Measurements</b> Visual Examination Contact Resistance	<b>Last cycle in each direction</b> No open or short circuits  No evidence of damage Para. 9.9 of ESCC 3402 Centre Contact	- - - -	-	- - - 3.0	- - - mΩ
07	Shock or Bump	Para. 9.11 Full Engagement	<b>Final Measurements</b> Interface Dimensions Visual Examination Contact Resistance	- No evidence of damage Para. 9.9 of ESCC 3402 Centre Contact	- - -	Figure 2(a) -		- - mΩ
08	Rapid Change of Temperature	Para. 9.12	<b>Final Measurements</b>  Contact Resistance Leakage Current Visual Examination	<b>After a recovery period of 24±2 hrs</b> Para. 9.9 of ESCC 3402 Centre Contact Table 2 Item 2 -	- - I <sub>L</sub> -	-	3.0 2.0 -	mΩ mA -
09	Climatic Sequence	Para. 9.13	<b>During Test</b> Dielectric Withstanding Voltage at low pressure (44mb) <b>Final Measurements</b>  External Visual Inspection Insulation Resistance Leakage Current	Table 1(b) Item 5  <b>After final Damp Heat cycle (within 1 to 24 hrs recovery)</b> Para. 9.8 of ESCC 3402 Table 2 Item 1 Table 2 Item 2	V <sub>ip</sub>  - R <sub>i</sub> I <sub>L</sub>	No flashover or breakdown  -		-  - MΩ mA
10	Cable Retention Force	Paras. 9.14 and 4.3.4 of this spec.	<b>During Test</b> Continuity	-	-	-	-	-
11	Cabling and Crimping Capability	Para. 9.15	Visual Examination  Dimensions Insulation Resistance Leakage Current	Para. 9.15 of ESCC 3402 Para. 9.15 of ESCC 3402 Table 2 Item 1 Table 2 Item 2	- - R <sub>i</sub> I <sub>L</sub>	Fig. 2(a) & 2(b)  -		-  MΩ mA

**NOTES:** See page 18.



**TABLE 6 - MEASUREMENTS AND INSPECTIONS ON COMPLETION OF ENVIRONMENTAL AND ENDURANCE TESTS (CONT'D)**

NO.	ESCC GENERIC SPEC. NO. 3402		MEASUREMENTS AND INSPECTIONS		SYMBOL	LIMITS		UNIT
	ENVIRONMENTAL AND ENDURANCE TESTS (1)	TEST METHOD AND CONDITIONS	IDENTIFICATION	CONDITIONS		MIN.	MAX.	
12	VSWR or Reflection Coefficient	Para. 9.16	VSWR	Para. 9.16 of ESCC 3402	-	Figure 2(b)		-
13	Corona Level	Para. 9.17	Corona	Para. 9.17 of ESCC 3402	-	Table 1 Item 7		-
14	Endurance	Paras. 9.18 and 4.3.6 of this spec.	<b>Final Measurements</b> Mating/Unmating Forces Contact Resistance  Visual Examination	Para. 4.3.5 of this spec. Para 9.9 of ESCC 3402 Centre Contact Shell Para. 9.18 of ESCC 3402	- - - -	- - 4.0 3.0 -	23  mΩ mΩ -	N.cm  mΩ mΩ -
15	RF Insertion Loss	Para. 9.19	Insertion Loss	Para. 9.19 of ESCC 3402	-	Figure 2(b)		dB
16	Corrosion	Para. 9.20	Visual Examination	Para. 9.20 of ESCC 3402 No exposure of base metal	-	-	-	-
17	Residual Magnetism	Para. 9.21	Magnetism	Not applicable	-	-	-	-
18	Soldering Proof	Para. 9.22	<b>Final Measurements</b> Interface Dimensions Mating/Unmating Forces Insulation Resistance Leakage Current Contact Resistance  External Visual Inspection	- Para. 4.3.5 of this spec. Table 2 Item 1 Table 2 Item 2 Para 9.9 of ESCC 3402 Centre Contact Shell Para. 9.8 of ESCC 3402	- - R <sub>i</sub> I <sub>L</sub> - - -	Figure 2(b) - 5000 - 2.0 - - -	23 - - 2.0 - 3.0 2.0 -	- N.cm MΩ mA mΩ mΩ -
19	RF Leakage	Para. 9.23	Leakage	Para. 9.23 of ESCC 3402	-	Figure 2(b)		dB
20	High Temperature Storage	Paras. 9.24 and 4.8.6 of this spec.	<b>Final Measurements</b> Mating/Unmating Forces Insulation Resistance Leakage Current Contact Retention Visual Examination Contact Resistance  External Visual Inspection	Para. 4.3.5 of this spec. Table 2 Item 1 Table 2 Item 2 Para. 4.3.9 of this spec. - Para 9.9 of ESCC 3402 Centre Contact Shell Para. 9.8 of ESCC 3402	- R <sub>i</sub> I <sub>L</sub> - - - -	- 5000 - 2.0 Para. 4.3.9 - - -	23 - - 2.0 - - 8.0 7.5 -	N.cm MΩ mA - - mΩ mΩ -
21	Permanence of Marking	Para. 9.27	Marking Permanence	Para. 9.27 of ESCC 3402	-	-	-	-
22	Plating Thickness (Hermetic Types Only)	Para. 9.8	Plating Thickness	Not Applicable	-	-	-	-

**NOTES**

1. The tests in this table refer to either Chart IV or V and shall be used as applicable.

**FIGURE 2(b) - TYPE VARIANTS**

**VARIANT 01 - STRAIGHT MALE- MALE ADAPTOR**

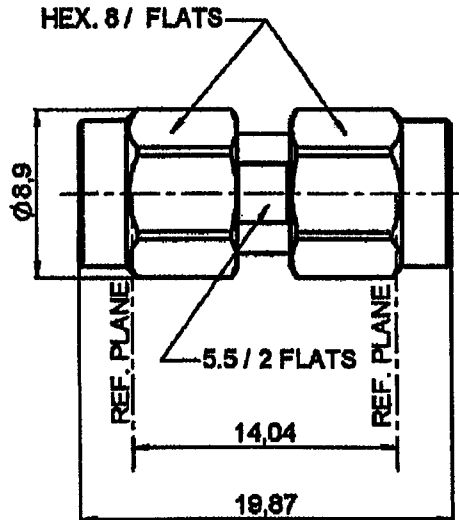

All dimensions are in mm

ELECTRICAL CHARACTERISTICS	VALUES	UNITS
Frequency Range	0-40	GHz
Maximum VSWR	$1.03 + 0.003 \times f$ (GHz)	-
Maximum Insertion Loss	$0.03 \times \sqrt{f}$ (GHz)	dB
RF Leakage	$-(90 - f)$ (GHz)	dB
Dielectric Withstanding Voltage (Sea level) (Voltage Proof Test)	750	Vrms
Power Handling Category (Figure 1(a))	Category I	-

MECHANICAL CHARACTERISTICS	VALUES	UNITS
Minimum Centre Contact Retention Force (axial)	27	N
Minimum Centre Contact Retention Torque	Not applicable	N.cm
Minimum Cable Retention Force	Not applicable	N
Minimum Cable Retention Torque Value	Not applicable	N.cm
Maximum weight	5.5	g

OTHER CHARACTERISTICS	VALUES	UNITS
Rapid Change of Temperature - peak value	165	°C
Operating Temperature Range	-65 to +165	°C
Maximum Leakage (panel sealed connectors)	Not applicable	-
Maximum Leakage (hermetically sealed connectors)	Not applicable	-
Solderability	Not applicable	-
Soldering proof	Not applicable	-
Cables used	Not applicable	-

**FIGURE 2(b) - TYPE VARIANTS**

**VARIANT 01 - STRAIGHT FEMALE- FEMALE ADAPTOR**

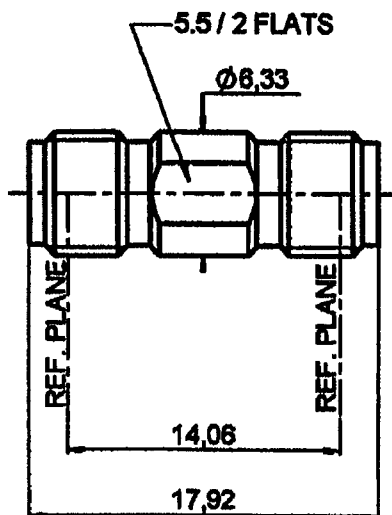

All dimensions are in mm

ELECTRICAL CHARACTERISTICS	VALUES	UNITS
Frequency Range	0-40	GHz
Maximum VSWR	$1.03 + 0.003 \times f$ (GHz)	-
Maximum Insertion Loss	$0.03 \times \sqrt{f}$ (GHz)	dB
RF Leakage	$-(90 - f)$ (GHz)	dB
Dielectric Withstanding Voltage (Sea level) (Voltage Proof Test)	750	Vrms
Power Handling Category (Figure 1(a))	Category I	-

MECHANICAL CHARACTERISTICS	VALUES	UNITS
Minimum Centre Contact Retention Force (axial)	27	N
Minimum Centre Contact Retention Torque	Not applicable	N.cm
Minimum Cable Retention Force	Not applicable	N
Minimum Cable Retention Torque Value	Not applicable	N.cm
Maximum weight	3.0	g

OTHER CHARACTERISTICS	VALUES	UNITS
Rapid Change of Temperature - peak value	165	°C
Operating Temperature Range	-65 to +165	°C
Maximum Leakage (panel sealed connectors)	Not applicable	-
Maximum Leakage (hermetically sealed connectors)	Not applicable	-
Solderability	Not applicable	-
Soldering proof	Not applicable	-
Cables used	Not applicable	-

**FIGURE 2(b) - TYPE VARIANTS**

**VARIANT 01 - STRAIGHT MALE- FEMALE ADAPTOR**

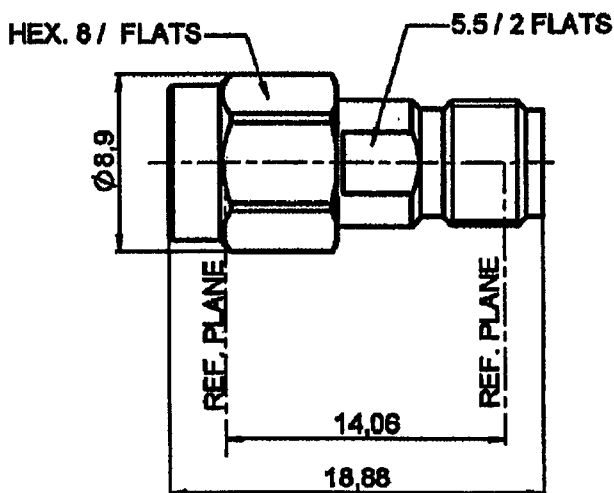

All dimensions are in mm

ELECTRICAL CHARACTERISTICS	VALUES	UNITS
Frequency Range	0-40	GHz
Maximum VSWR	$1.03 + 0.003 \times f$ (GHz)	-
Maximum Insertion Loss	$0.03 \times \sqrt{f}$ (GHz)	dB
RF Leakage	$-(90 - f)$ (GHz)	dB
Dielectric Withstanding Voltage (Sea level) (Voltage Proof Test)	750	Vrms
Power Handling Category (Figure 1(a))	Category I	-

MECHANICAL CHARACTERISTICS	VALUES	UNITS
Minimum Centre Contact Retention Force (axial)	27	N
Minimum Centre Contact Retention Torque	Not applicable	N.cm
Minimum Cable Retention Force	Not applicable	N
Minimum Cable Retention Torque Value	Not applicable	N.cm
Maximum weight	4.1	g

OTHER CHARACTERISTICS	VALUES	UNITS
Rapid Change of Temperature - peak value	165	°C
Operating Temperature Range	-65 to +165	°C
Maximum Leakage (panel sealed connectors)	Not applicable	-
Maximum Leakage (hermetically sealed connectors)	Not applicable	-
Solderability	Not applicable	-
Soldering proof	Not applicable	-
Cables used	Not applicable	-