



Pages 1 to 16

**CONTACTS, ELECTRICAL, CRIMP FOR 3401/077
MICROMINATURE CONNECTORS BASED ON TYPE MDMA**

ESCC Detail Specification No. 3401/078

Issue 2	July 2009
---------	-----------



Document Custodian: European Space Agency - see <https://escies.org>

LEGAL DISCLAIMER AND COPYRIGHT

European Space Agency, Copyright © 2009. All rights reserved.

The European Space Agency disclaims any liability or responsibility, to any person or entity, with respect to any loss or damage caused, or alleged to be caused, directly or indirectly by the use and application of this ESCC publication.

This publication, without the prior permission of the European Space Agency and provided that it is not used for a commercial purpose, may be:

- copied in whole, in any medium, without alteration or modification.
- copied in part, in any medium, provided that the ESCC document identification, comprising the ESCC symbol, document number and document issue, is removed.

DOCUMENTATION CHANGE NOTICE

(Refer to <https://escies.org> for ESCC DCR content)

DCR No.	CHANGE DESCRIPTION
520	Specification upissued to incorporate editorial and technical changes per DCR.

TABLE OF CONTENTS

1.	<u>GENERAL</u>	<u>6</u>
1.1	Scope	6
1.2	Type Variants	6
1.3	Maximum Ratings	6
1.4	Parameter Derating Information (Figure 1)	6
1.5	Physical Dimensions	6
2.	<u>APPLICABLE DOCUMENTS</u>	<u>9</u>
3.	<u>TERMS, DEFINITIONS, ABBREVIATIONS, SYMBOLS AND UNITS</u>	<u>9</u>
4.	<u>REQUIREMENTS</u>	<u>9</u>
4.1	General	9
4.2	Deviations from Generic Specification	9
4.2.1	Deviations from Special In-Process Controls	9
4.2.2	Deviations from Final Production Tests (Chart II)	9
4.2.3	Deviations from Burn-in and Electrical Measurements (Chart III)	9
4.2.4	Deviations from Qualification Tests (Chart IV)	10
4.2.5	Deviations from Lot Acceptance Tests (Chart V)	10
4.3	Mechanical Requirements	10
4.3.1	Dimension Check	10
4.3.2	Weight	10
4.3.3	Contact Capability	10
4.3.4	Contact Retention (in Insert)	10
4.3.5	Mating and Unmating Forces	10
4.3.6	Insert Retention (in Shell)	10
4.3.7	Jackscrew Retention	10
4.3.8	Contact Insertion and Withdrawal Forces	10
4.3.9	Engagement and Separation Forces	10
4.3.10	Oversize Pin Exclusion	10
4.3.11	Probe Damage	11
4.3.12	Solderability	11
4.4	Materials and Finishes	11
4.4.1	Female Contacts	11
4.4.2	Male Contacts	11
4.5	Marking	11
4.5.1	General	11
4.5.2	The ESCC Component Number	11
4.5.3	Traceability Information	11
4.6	Electrical Measurements	12
4.6.1	Electrical Measurements at Room Temperature	12
4.6.2	Electrical Measurements at High and Low Temperatures	12
4.6.3	Circuit for Electrical Measurements (Figure 4)	12
4.7	Burn-in and Electrical Measurements (Tables 4 and 5)	12
4.8	Environmental and Endurance Tests	12
4.8.1	Measurements and Inspections on Completion of Environmental Tests	12
4.8.2	Measurements and Inspections at Intermediate Points during Endurance Tests	12
4.8.3	Measurements and Inspections on Completion of Endurance Tests	12
4.8.4	Conditions for Operating Life Test (Part of Endurance Testing)	12
4.8.5	Electrical Circuits for Operating Life Test	12
4.8.6	Conditions for High Temperature Storage Test (Part of Endurance Testing)	12



APPENDIX 'A' - AGREED DEVIATIONS FOR C & K COMPONENTS

1. GENERAL

1.1 SCOPE

This specification details the ratings, physical and electrical characteristics, test and inspection data for Contacts, Electrical, Crimp, for 3401/077 Microminiature Connectors based on type MDMA.

These contacts shall be packed separately from the connectors and may be procured either with the connectors or separately.

This specification shall be read in conjunction with:

- (a) ESCC Generic Specification No. 3401, Connectors, Electrical, Non-Filtered, Circular and Rectangular.
- (b) ESCC Detail Specification No. 3401/077, Connectors, Electrical, Rectangular, Microminiature, Removable Crimp Contacts, based on Type MDMA.

the requirements of which are supplemented herein.

1.2 TYPE VARIANTS

The contact type variants are scheduled in Table 1(a).

1.3 MAXIMUM RATINGS

The maximum ratings, which shall not be exceeded at any time during use or storage, applicable to the contacts specified herein, are scheduled in Table 1(b).

1.4 PARAMETER DERATING INFORMATION (FIGURE 1)

Not applicable.

1.5 PHYSICAL DIMENSIONS

The physical dimensions of the contacts specified herein are shown in Figure 2.

TABLE 1(a) - TYPE VARIANTS

Characteristics	Variant		Unit
	01	02	
Type	Male	Female	-
Mating End Size	24	24	AWG
Crimp Barrel Size	26	26	AWG
Accept Wire	25, 26, 28	25, 26, 28	AWG
Rated Current for AWG 26 insulated and AWG 25 un-insulated solid wire	2.5	2.5	A
Rated Current for AWG 28 insulated wire	1.5	1.5	A
Maximum Weight	0.03	0.06	g

Characteristics			Variant		Unit
			01	02	
Engagement and Separation - Contact Engagement Force	Maximum Force		1.667	-	N
	Test Pin Diameter	Minimum	0.559	-	mm
		Maximum	0.564	-	mm
Engagement and Separation - Contact Separation Force	Maximum Force		0.137	-	N
	Test Pin Diameter	Minimum	0.582	-	mm
		Maximum	0.587	-	mm
Contact Capability - Pick-Up Weight	Weight		14	-	g
	Test Pin Diameter	Minimum	0.582	-	mm
		Maximum	0.587	-	mm
	Minimum Insertion Depth		1.5	-	mm
Contact Capability - Drop Weight	Weight		170	-	g
	Test Pin Diameter	Minimum	0.559	-	mm
		Maximum	0.564	-	mm
	Minimum Insertion Depth		1.5	-	mm
Contact Retention Force (in Insert)		Minimum	22.25	22.25	N
Contact Insertion and Withdrawal Forces		Maximum	10	10	N

TABLE 1(b) - MAXIMUM RATINGS

No.	Characteristics	Symbol	Maximum Ratings	Unit
1	Rated Current	I_R	See Table 1(a)	A
2	Operating Temperature Range	T_{op}	-55 to +125	°C
3	Storage Temperature Range	T_{stg}	-65 to +125	°C

FIGURE 1 - PARAMETER DERATING INFORMATION

Not applicable.

FIGURE 2 - PHYSICAL DIMENSIONS

Figure 2.1 - Male Contact

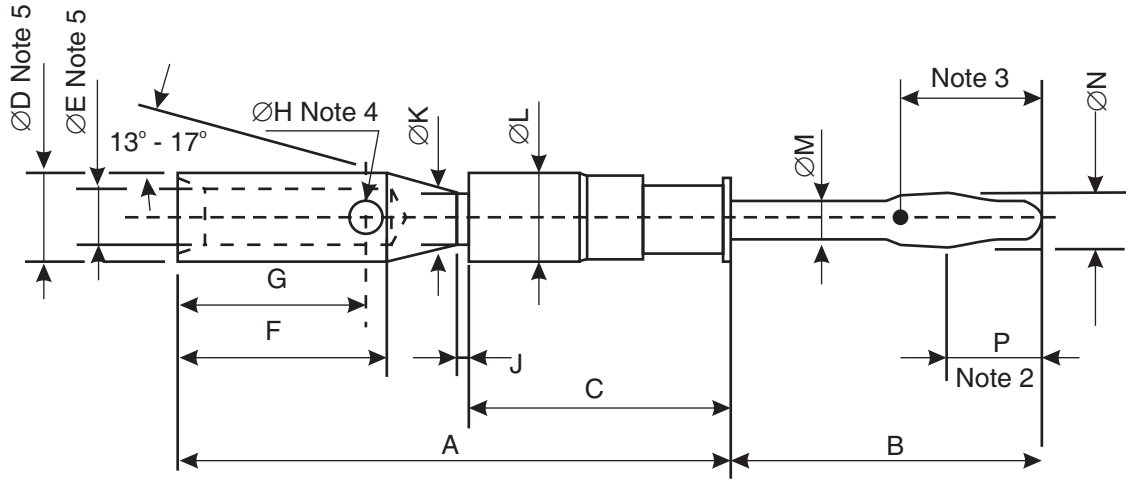

	A	B	C	ØD	ØE	F	G	ØH	J	ØK	ØL	ØM	ØN	P
Min	5.7	3.17	2.7	0.92	0.56	2.1	1.8	-	0.05	0.52	0.92	0.42	0.65	0.9
Max	5.9	3.4	2.8	0.96	0.6	2.4	2.1	0.45	0.15	0.58	0.96	0.45	0.8	1.4

NOTES:

1. All dimensions are in millimetres.
2. Measurement point of ØN.
3. Measurement point for plating thickness: 1.5 ±0.5mm
4. Inspection hole may be H x H square and shall only penetrate one wall of the crimp barrel.
5. ØD and ØE to be concentric within 0.07mm

Figure 2.2 - Female Contact

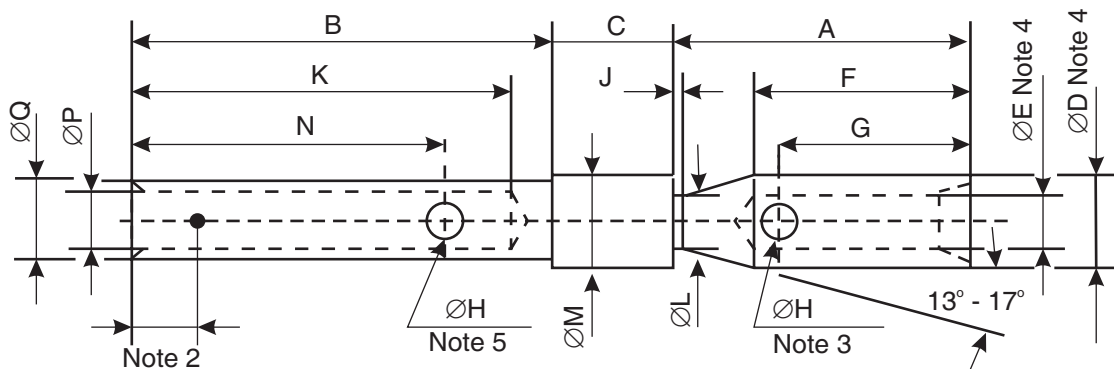

	A	B	C	ØD	ØE	F	G	ØH	J	K	ØL	ØM	N	ØP	ØQ
Min	2.9	4.17	1.1	0.92	0.56	2.1	1.8	-	0.05	3.5	0.52	0.92	3	0.56	0.81
Max	3.1	4.29	1.3	0.96	0.6	2.4	2.1	0.45	0.15	-	0.58	0.98	3.3	0.6	0.85

NOTES:

1. All dimensions are in millimetres.
2. Measurement point for plating thickness: $1.5 \pm 0.5\text{mm}$
3. Inspection hole may be H x H square and shall only penetrate one wall of the crimp barrel.
4. ØD and ØE to be concentric within 0.04mm
5. Optional hole to facilitate plating inside ØP .

2. APPLICABLE DOCUMENTS

The following documents form part of this specification and shall be read in conjunction with it:

- (a) ESCC Generic Specification No. 3401, Connectors, Electrical, Non-Filtered, Circular and Rectangular.
- (b) ESCC Detail Specification No. 3401/077, Connectors, Electrical, Rectangular, Microminiature, Removable Crimp Contacts, based on Type MDMA.
- (c) MIL-DTL-45204, Gold Plating, Electro-deposited.
- (d) MIL-C-14550, Copper Plating, Electro-deposited.

3. TERMS, DEFINITIONS, ABBREVIATIONS, SYMBOLS AND UNITS

For the purpose of this specification, the terms, definitions, abbreviations, symbols and units specified in ESCC Basic Specification No. 21300 shall apply.

4. REQUIREMENTS**4.1 GENERAL**

The complete requirements for procurement of the contacts specified herein are stated in this specification and ESCC Generic Specification No. 3401. Deviations from the Generic Specification, applicable to this Detail Specification only, are listed in Para. 4.2.

Deviations from the applicable Generic Specification and this Detail Specification, formally agreed with specific Manufacturers on the basis that the alternative requirements are equivalent to the ESCC requirements and do not affect the components' reliability, are listed in the appendices attached to this specification.

4.2 DEVIATIONS FROM GENERIC SPECIFICATION**4.2.1 Deviations from Special In-Process Controls**

None.

4.2.2 Deviations from Final Production Tests (Chart II)

- (a) Para. 9.4, Contact Capability: This test shall be performed on the male contacts. For details, see Para. 4.3.3 of this specification.
- (b) Para. 9.5, Magnetism Level: Not applicable.

4.2.3 Deviations from Burn-in and Electrical Measurements (Chart III)

Chart III is not applicable.

4.2.4 Deviations from Qualification Tests (Chart IV)

- (a) Para. 9.29, Oversize Pin Exclusion: Not applicable.
- (b) Para. 9.30, Probe Damage: Not applicable.
- (c) Para. 9.31, Solderability: Not applicable.

4.2.5 Deviations from Lot Acceptance Tests (Chart V)

- (a) Para. 9.29, Oversize Pin Exclusion: Not applicable.
- (b) Para. 9.30, Probe Damage: Not applicable.

4.3 MECHANICAL REQUIREMENTS

4.3.1 Dimension Check

The dimensions of the contacts specified herein shall be verified in accordance with the requirements set out in Para. 9.6 of ESCC Generic Specification No. 3401 and shall conform to those shown in Figure 2 of this specification.

4.3.2 Weight

The maximum weight of the contacts specified herein shall be as specified in Table 1(a).

4.3.3 Contact Capability

For the purpose of this test, the pick-up and drop weights shall be as specified in Table 1(a).

4.3.4 Contact Retention (in Insert)

The contact retention force shall be as specified in Table 1(a).

4.3.5 Mating and Unmating Forces

As specified in ESCC Detail Specification No. 3401/077.

4.3.6 Insert Retention (in Shell)

As specified in ESCC Detail Specification No. 3401/077.

4.3.7 Jackscrew Retention

As specified in ESCC Detail Specification No. 3401/077.

4.3.8 Contact Insertion and Withdrawal Forces

The contact insertion and withdrawal forces shall be as specified in Table 1(a).

4.3.9 Engagement and Separation Forces

The contact engagement and separation forces of the male contacts shall be tested to a depth of 1.5mm with the applicable test gauge fixtures specified in Figure 4 of this specification, and shall not exceed the values of Table 1(a).

4.3.10 Oversize Pin Exclusion

Not applicable.

4.3.11 Probe Damage
Not applicable.

4.3.12 Solderability
Not applicable.

4.4 MATERIALS AND FINISHES

The materials and finishes shall be as specified herein. Where a definite material is not specified, a material which will enable the connectors specified herein to meet the performance requirements of this specification shall be used. Acceptance or approval of any constituent material does not guarantee acceptance of the finished product.

4.4.1 Female Contacts
Copper alloy with an underplate of 1 μ m minimum of copper to MIL-C-14550, gold plated with 1.27 μ m minimum of gold, Type 2, Grade C of MIL-DTL-45204.

4.4.2 Male Contacts
Copper alloy with an underplate of 1 μ m minimum of copper to MIL-C-14550, gold plated with 1.27 μ m minimum of gold, Type 2, Grade C of MIL-DTL-45204.

4.5 MARKING

4.5.1 General

The marking of components delivered to this specification shall be in accordance with the requirements of ESCC Basic Specification No. 21700 and the following paragraphs.

These components being too small to accommodate the marking as specified hereafter, the full marking information shall accompany each lot of components in its primary package. Such marking shall comprise:

- (a) The ESCC qualified components symbol (for ESCC qualified components only).
- (b) The ESCC Component Number.
- (c) Traceability Information.

4.5.2 The ESCC Component Number

The ESCC Component Number shall be constituted and marked as follows:

340107801B

- Detail Specification Number: 3401078
- Type Variant (See Table 1(a)): 01
- Testing Level: B

4.5.3 Traceability Information

Traceability information shall be marked in accordance with ESCC Basic Specification No. 21700.

4.6 ELECTRICAL MEASUREMENTS

4.6.1 Electrical Measurements at Room Temperature

The parameters to be measured in respect of electrical characteristics are scheduled in Table 2. Unless otherwise specified, the measurements shall be performed at $T_{amb} = +22 \pm 3^{\circ}C$.

4.6.2 Electrical Measurements at High and Low Temperatures

Not applicable.

4.6.3 Circuit for Electrical Measurements (Figure 4)

Not applicable.

4.7 BURN-IN AND ELECTRICAL MEASUREMENTS (TABLES 4 AND 5)

Not applicable.

4.8 ENVIRONMENTAL AND ENDURANCE TESTS

4.8.1 Measurements and Inspections on Completion of Environmental Tests

The parameters to be measured and inspections to be performed on completion of environmental testing are scheduled in Table 6. Unless otherwise specified, these measurements shall be performed at $T_{amb} = +22 \pm 3^{\circ}C$.

4.8.2 Measurements and Inspections at Intermediate Points during Endurance Tests

Not applicable.

4.8.3 Measurements and Inspections on Completion of Endurance Tests

The parameters to be measured and inspections to be performed on completion of endurance tests shall be those specified in Table 6. Unless otherwise specified, these measurements shall be performed at $T_{amb} = +22 \pm 3^{\circ}C$.

4.8.4 Conditions for Operating Life Test (Part of Endurance Testing)

Not applicable.

4.8.5 Electrical Circuits for Operating Life Test

Not applicable.

4.8.6 Conditions for High Temperature Storage Test (Part of Endurance Testing)

The requirements for the high temperature storage test are specified in Section 9 of ESCC Generic Specification No. 3401. The conditions for high temperature storage testing shall be the maximum storage temperature specified in Table 1(b) of this specification.

TABLE 2 - ELECTRICAL MEASUREMENTS AT ROOM TEMPERATURE

No.	Characteristics	Symbol	ESCC 3401 Test Method	Test Condition	Limit		Unit
					Min	Max	
1	Contact Resistance (Low Level Current)	R_{cl}	Para. 9.1.1.3	Para. 9.1.1.3	-	6	m Ω

No.	Characteristics	Symbol	ESCC 3401 Test Method	Test Condition	Limit		Unit
					Min	Max	
2	Contact Resistance (Rated Current)	R_{cr}	Para. 9.1.1.3	Para. 9.1.1.3 and Table 1(a)	-	5	mΩ

TABLES 3, 4 AND 5

Not applicable.

FIGURE 3 - GAUGE FIXTURE

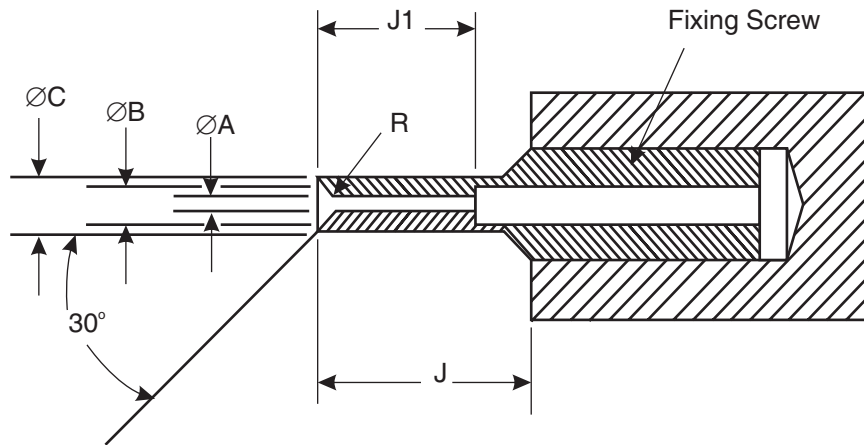

MAXIMUM GAUGE (WEIGHT: 170g)

Symbols	Dimensions mm		Remarks
	Min	Max	
ØA	0.559	0.564	
ØB	0.749	0.775	
ØC	0.813	0.825	
J	4	-	
J1	3.13	3.23	
R	0.381	0.483	Note 1

MINIMUM GAUGE (WEIGHT: 14g)

Symbols	Dimensions mm		Remarks
	Min	Max	
ØA	0.582	0.587	
ØB	0.749	0.775	
ØC	0.813	0.825	
J	4	-	
J1	3.13	3.23	
R	0.381	0.483	Note 1

NOTES:

1. Radius 'R', must be tangential to entry chamfer and ØA.
2. ØA and entry chamfer must be polished to a 3.2µm smooth machined surface (N8 per ISO)

1302:2002).

TABLE 6 - MEASUREMENTS AND INSPECTIONS ON COMPLETION OF ENVIRONMENTAL AND ENDURANCE TESTS

No.	ESCC Generic Spec. No. 3401		Measurements and Inspections		Symbol	Limits		Unit
	Environmental and Endurance Tests Note 1	Test Method and Conditions	Identification	Conditions		Min	Max	
01	Seal Test	Para. 9.9	Not applicable					
02	Wiring	Para. 9.10 & Table 1(a) of this spec.	Low Level Contact Resistance	Table 2, Item 1	R_{cl}	Table 2, Item 1		mΩ
03	Vibration	Para. 9.11	ESCC 3401/077					
04	Shock or Bump	Para. 9.12	ESCC 3401/077					
05	Climatic Sequence	Para. 9.13	ESCC 3401/077					
06	Plating Thickness	Para. 9.14	Thickness	-	-	Paras. 4.4.1 and 4.4.2 of this spec		
07	Joint Strength	Para. 9.15	ESCC 3401 Para. 9.15.3	-	-	ESCC 3401 Para. 9.15		
08	Rapid Change of Temperature	Para. 9.16	ESCC 3401/077					
09	Contact Retention (in Insert)	Para. 9.17 & 4.3.4 of this spec	Contact Displacement	-	-	ESCC 3401 Para. 9.17		
10	Endurance	Para. 9.18	Initial Measurements	Table 2, Item 1	R_{cl}	Table 2, Item 1	Record Values	mΩ
			Low Level Contact Resistance					
11	Permanence of Marking	Para. 9.19	Final Measurements	Table 2, Item 1	ΔR_{cl}	-	3	mΩ
			Low Level Contact Resistance Drift					
12	Mating/Unmating Forces	Para. 9.20	ESCC 3401/077					
13	High Temperature Storage	Para. 9.21	Initial Measurements	Table 2, Item 1	R_{cl}	Table 2, Item 1	Record Values	mΩ
			Low Level Contact Resistance					
13	High Temperature Storage	Para. 9.21	Final Measurements	Table 2, Item 1	ΔR_{cl}	-	3	mΩ
			Low Level Contact Resistance Drift					

No.	ESCC Generic Spec. No. 3401		Measurements and Inspections		Symbol	Limits		Unit
	Environmental and Endurance Tests Note 1	Test Method and Conditions	Identification	Conditions		Min	Max	
			Rated Current Contact Resistance Contact Retention (in Insert)	Table 2, Item 2 Para. 4.3.4 of this spec.	R _{cr} -	Table 2, Item 2 ESCC 3401 Para. 9.17		mΩ N
14	Corrosion	Para. 9.22	Visual Examination	-	-	-	-	
15	Insert Retention (in Shell)	Para. 9.23 & 4.3.6 of this spec	ESCC 3401/077					
16	Jackscrew Retention	Para. 9.24 & 4.3.7 of this spec	ESCC 3401/077					
17	High Temperature Measurements	Para. 9.25	ESCC 3401/077					
18	Overload Test	Para. 9.26	Rated Current Contact Resistance	Table 2, Item 2	R _{cr}	Table 2, Item 2		mΩ
19	Maintenance Ageing	Para. 9.27	Visual Examination Contact Retention (in insert) Contact Insertion & Withdrawal Forces	- Para. 4.3.4 of this spec. Para. 4.3.8 of this spec.	- - -	-	-	N N
20	Engage/Separation Forces	Para. 9.28 & Para. 4.3.9 of this spec.	Force	Para. 4.3.9 of this spec.	F	Para. 4.3.9		N
21	Oversize Pin Exclusion	Para. 9.29 & Para. 4.3.10 of this spec.	Not applicable					
22	Probe Damage	Para. 9.30 & Para. 4.3.11 of this spec.	Not applicable					
23	Solderability	Para. 9.31 & Para. 4.3.12 of this spec.	Not applicable					

NOTES:

1. The tests in this table refer to either Chart IV or V and shall be used as applicable.

APPENDIX 'A' - AGREED DEVIATIONS FOR C & K COMPONENTS

ITEMS AFFECTED	DESCRIPTION OF DEVIATIONS	
Deviations from Qualification Tests (Chart IV) and Lot Acceptance Tests (Chart V)	Para. 9.15, Joint Strength: The contacts shall be crimped to insulated stranded wire AWG26 and AWG28, and to uninsulated solid wire AWG25. Minimum tensile strengths are as follows:	
	Wire Sizes (Male and Female Contacts)	Minimum Tensile Strength (N)
	AWG 26	22
	AWG 28	13
	AWG 25 (Solid, Uninsulated)	22
	The value of failure shall be recorded together with the failure mode ("pull-out", "break in crimp" or "break in wire").	