



Pages 1 to 17

DIODES, SILICON, SWITCHING

BASED ON TYPES 1N5807, 1N5809, 1N5811 AND 1N5811U

ESCC Detail Specification No. 5101/013

Issue 2	September 2009
---------	----------------



Document Custodian: European Space Agency - see <https://escies.org>

LEGAL DISCLAIMER AND COPYRIGHT

European Space Agency, Copyright © 2009. All rights reserved.

The European Space Agency disclaims any liability or responsibility, to any person or entity, with respect to any loss or damage caused, or alleged to be caused, directly or indirectly by the use and application of this ESCC publication.

This publication, without the prior permission of the European Space Agency and provided that it is not used for a commercial purpose, may be:

- copied in whole, in any medium, without alteration or modification.
- copied in part, in any medium, provided that the ESCC document identification, comprising the ESCC symbol, document number and document issue, is removed.

DOCUMENTATION CHANGE NOTICE

(Refer to <https://escies.org> for ESCC DCR content)

DCR No.	CHANGE DESCRIPTION
447, 449, 526	Specification up issued to incorporate editorial and technical changes per DCR.

TABLE OF CONTENTS

1.	<u>GENERAL</u>	5
1.1	Scope	5
1.2	Applicable Documents	5
1.3	Terms, Definitions, Abbreviations, Symbols and Units	5
1.4	The ESCC Component Number and Component Type Variants	5
1.4.1	The ESCC Component Number	5
1.4.2	Component Type Variants	5
1.5	Maximum Ratings	6
1.6	Handling Precautions	7
1.7	Physical Dimensions and Terminal Identification	7
1.7.1	Axial Lead Package	7
1.7.2	Leadless Chip Carrier Package (LCC2B) - 2 Terminal	8
1.7.3	Metal Electrode Face Package (MELF-E) - 2 Terminal	9
1.8	Functional Diagram	9
1.9	Materials and Finishes	9
2.	<u>REQUIREMENTS</u>	10
2.1	General	10
2.1.1	Deviations from the Generic Specification	10
2.1.1.1	Deviations from Special In-Process Controls (Chart F2)	10
2.1.1.2	Deviations from Screening Tests (Chart F3)	10
2.1.1.3	Deviations from Qualification and Periodic Tests (Chart F4)	10
2.2	Marking	10
2.3	Terminal Strength	11
2.4	Electrical Measurements at Room, High and Low Temperatures	11
2.4.1	Room Temperature Electrical Measurements	11
2.4.2	High and Low Temperatures Electrical Measurements	13
2.4.3	Notes to Electrical Measurement Tables	13
2.5	Parameter Drift Values	13
2.6	Intermediate and End-Point Electrical Measurements	14
2.7	High Temperature Reverse Bias Burn-in Conditions	14
2.8	Power Burn-in Conditions	15
2.9	Operating Life Conditions	15
APPENDIX 'A'		17

1. GENERAL

1.1 SCOPE

This specification details the ratings, physical and electrical characteristics and test and inspection data for the component type variants and/or the range of components specified below. It supplements the requirements of, and shall be read in conjunction with, the ESCC Generic Specification listed under Applicable Documents.

1.2 APPLICABLE DOCUMENTS

The following documents form part of this specification and shall be read in conjunction with it:

- (a) ESCC Generic Specification No. 5000
- (b) MIL-STD-750, Test Methods and Procedures for Semiconductor Devices

1.3 TERMS, DEFINITIONS, ABBREVIATIONS, SYMBOLS AND UNITS

For the purpose of this specification, the terms, definitions, abbreviations, symbols and units specified in ESCC Basic Specification No. 21300 shall apply.

1.4 THE ESCC COMPONENT NUMBER AND COMPONENT TYPE VARIANTS

1.4.1 The ESCC Component Number

The ESCC Component Number shall be constituted as follows:

Example: 510101301

- Detail Specification Reference: 5101013
- Component Type Variant Number: 01 (as required)

1.4.2 Component Type Variants

The component type variants applicable to this specification are as follows:

Variant Number	Based on Type	Case	Breakdown Voltage $V_{(BR)}$ (V)	Working Peak Reverse Voltage V_{RWM} (V)	Forward Surge Current I_{FSM} (A)	Terminal Material and/or Finish	Weight max g
01	1N5807	Axial Lead	60	50	125	O1	0.9
02	1N5807	Axial Lead	60	50	125	A3 or A4	0.9
05	1N5809	Axial Lead	110	100	125	O1	0.9
06	1N5809	Axial Lead	110	100	125	A3 or A4	0.9
09	1N5811	Axial Lead	160	150	125	O1	0.9
10	1N5811	Axial Lead	160	150	125	A3 or A4	0.9
11	1N5811U	LCC2B	160	150	100	2	0.18

Variant Number	Based on Type	Case	Breakdown Voltage $V_{(BR)}$ (V)	Working Peak Reverse Voltage V_{RWM} (V)	Forward Surge Current I_{FSM} (A)	Terminal Material and/or Finish	Weight max g
12	1N5811U	LCC2B	160	150	100	4	0.18
13	1N5807US	MELF-E	60	50	125	A3 or A4	0.65
14	1N5809US	MELF-E	110	100	125	A3 or A4	0.65
15	1N5811US	MELF-E	160	150	125	A3 or A4	0.65

The terminal material and/or finish shall be in accordance with the requirements of ESCC Basic Specification No. 23500.

1.5 MAXIMUM RATINGS

The maximum ratings shall not be exceeded at any time during use or storage.

Maximum ratings shall only be exceeded during testing to the extent specified in this specification and when stipulated in Test Methods and Procedures of the ESCC Generic Specification.

Characteristics	Symbols	Maximum Ratings	Unit	Remarks
Forward Surge Current	I_{FSM}	Note 1	A	Notes 2, 3
Working Peak Reverse Voltage	V_{RWM}	Note 1	V	
Average Output Rectified Current	I_O	6	A	Note 4, 5
Operating Temperature Range (Ambient Temperature)	T_{op}	-65 to +175	°C	Note 6
Junction Temperature	T_j	+175	°C	
Storage Temperature Range	T_{stg}	-65 to +175	°C	Note 6
Soldering Temperature	T_{sol}	+245	°C	Note 7
Thermal Resistance, Variants 01, 02, 05, 06, 09, 10 Variants 11 to 15	R_{th}	22 6.5	°C/W	Note 8

NOTES:

- See Component Type Variants for value.
- Sinusoidal pulse of 8.3ms duration for Variants 01, 02, 05, 06, 09, 10, 13, 14, 15 and 10ms for Variants 11, 12.
- At $T_{amb} \leq +25^\circ C$.
- For Variants 01, 02, 05, 06, 09, 10: specified on the lead 9.5mm from the body (T_{lead}).
For Variants 11, 12: specified at the body terminal (T_{case}).
For Variants 13 to 15: specified at the body terminal (T_{lead} at 0mm)
- For Variants 01, 02, 05, 06, 09, 10, 13, 14, 15: At $T_{lead} \geq +75^\circ C$, derate linearly to 0A at +175°C.
For Variants 11, 12: At $T_{case} \geq +136^\circ C$, derate linearly to 0A at +175°C.
- For Variants 02, 06, 10, 12, 13, 14, 15 with hot solder dip or tin-lead plating terminal finish all testing performed at $T_{amb} > +125^\circ C$ shall be carried out in a 100% inert atmosphere.
- For Variants 01, 02, 05, 06, 09, 10: Duration 10s maximum at a distance of not less than 1.5mm from the device body and the same package shall not be resoldered until 3 minutes have elapsed.
For Variants 11 to 15: Duration 5s maximum and the same package shall not be resoldered until 3

minutes have elapsed.

8. For Variants 01, 02, 05, 06, 09, 10: $R_{th(j-l)}$ specified on the lead 9.5mm from the body (T_{lead}).
 For Variants 11, 12: $R_{th(j-c)}$ specified at the body terminal (T_{case}).
 For Variants 11 to 15: $R_{th(j-l)}$ specified at the body terminal (T_{lead} at 0mm).

1.6 **HANDLING PRECAUTIONS**

These devices are susceptible to damage by electrostatic discharge. Therefore, suitable precautions shall be employed for protection during all phases of manufacture, testing, packaging, shipment and any handling.

These components are categorised as Class 3 per ESCC Basic Specification No. 23800 with a Minimum Critical Path Failure Voltage of 15000 Volts.

1.7 **PHYSICAL DIMENSIONS AND TERMINAL IDENTIFICATION**

1.7.1 **Axial Lead Package**

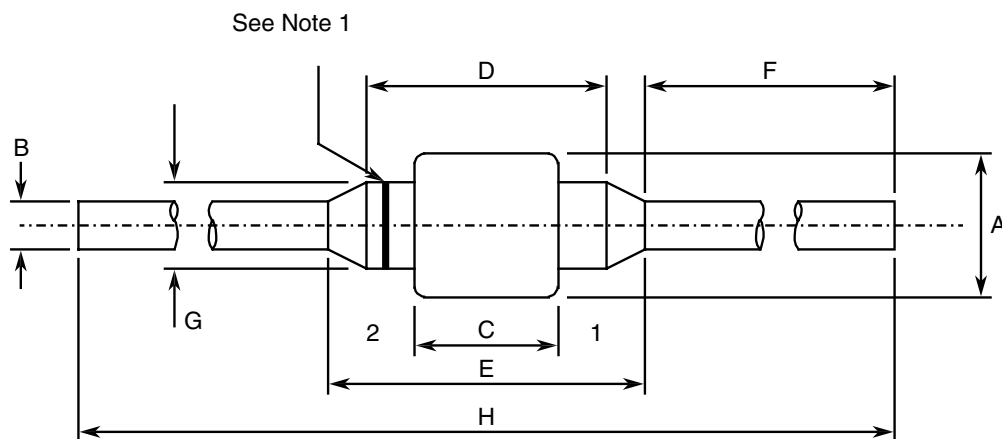

Symbols	Dimensions mm		Notes
	Min	Max	
A	-	3.7	
B	0.99	1.04	
C	-	2.8	
D	-	4.6	
E	-	7.6	
F	24.8	-	
G	-	3	
H	58.4	-	

NOTES:

1. Terminal identification: The cathode end shall be marked with a contrasting coloured band.

1.7.2 Leadless Chip Carrier Package (LCC2B) - 2 Terminal

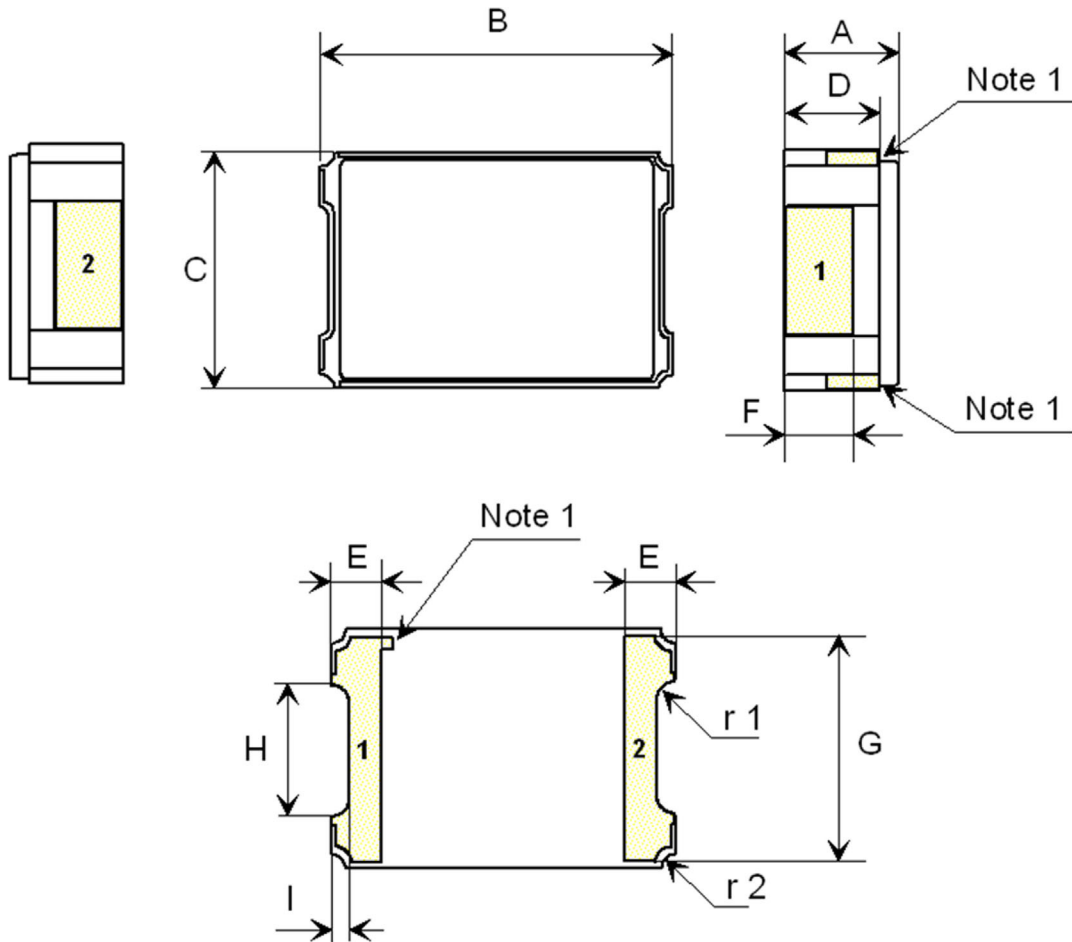

Symbols	Dimensions mm		Notes
	Min	Max	
A	2.04	2.42	2
B	5.27	5.6	
C	3.49	3.76	
D	1.71	2.09	
E	0.48	0.71	

NOTES:

1. Terminal identification: The anode is identified by metallisation in the two castellations and by the index mark on the bottom metallisation.
2. For Variant 12 dimension limits apply prior to solder coating of terminals.

1.7.3 Metal Electrode Face Package (MELF-E) - 2 Terminal

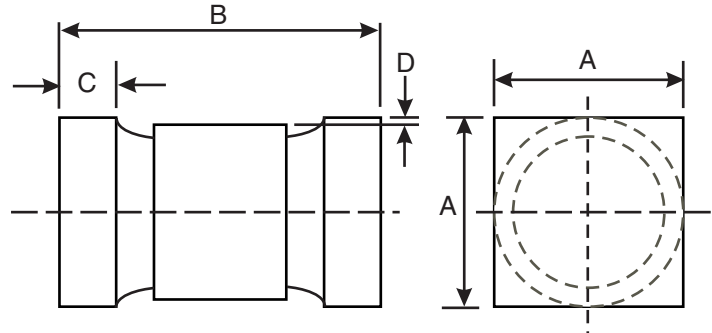

Symbols	Dimensions (mm)		Notes
	Min	Max	
A	3.48	3.76	2
B	5.08	5.72	2
C	0.48	0.71	2
D	0.08	-	3

NOTES:

1. Terminal identification: The cathode end shall be marked with either a contrasting coloured band, three dots spaced equally, or a colour dot on the face of the end tab.
2. Dimension limits apply prior to solder coating of terminals.
3. Minimum clearance of glass body to mounting surface on all orientations.

1.8 FUNCTIONAL DIAGRAM

Terminal 1: Anode
Terminal 2: Cathode

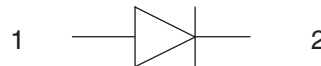

NOTES:

1. For LCC2B, the lid is not connected to any terminal.

1.9 MATERIALS AND FINISHES

Materials and finishes shall be as follows:

- a) Case
For Variants 01, 02, 05, 06, 09, 10, 13, 14, 15 the case shall be hermetically sealed and have a glass body.
For Variants 11, 12 the case shall be hermetically sealed and have an Aluminium Nitride body with a Kovar lid.

- b) Terminal Finish
As specified in Component Type Variants.

2. REQUIREMENTS

2.1 GENERAL

The complete requirements for procurement of the components specified herein are as stated in this specification and the ESCC Generic Specification. Permitted deviations from the Generic Specification, applicable to this specification only, are listed below.

Permitted deviations from the Generic Specification and this Detail Specification, formally agreed with specific Manufacturers on the basis that the alternative requirements are equivalent to the ESCC requirement and do not affect the component's reliability, are listed in the appendices attached to this specification.

2.1.1 Deviations from the Generic Specification

2.1.1.1 *Deviations from Special In-Process Controls (Chart F2)*

- (a) Bond Strength: Not applicable for Variants 01, 02, 05, 06, 09, 10, 13, 14, 15.
- (b) Die Shear: Not applicable for Variants 01, 02, 05, 06, 09, 10, 13, 14, 15.

2.1.1.2 *Deviations from Screening Tests (Chart F3)*

- (a) For Variants 01, 02, 05, 06, 09, 10, 13, 14, 15 only, following Temperature Cycling but prior to initial Parameter Drift Values, a Surge Current test shall be performed on all components as follows:
MIL-STD-750, Test Method 4066, condition A
 - $I_{FSM} = 125A$
 - 5 surges at a rate of 1 per minute and of duration 8.3ms.

After the Surge Current test Room Temperature Electrical Measurements shall be performed as specified herein. Any Failures shall be rejected.

- (b) Particle Impact Noise Detection: Not applicable for Variants 01, 02, 05, 06, 09, 10, 13, 14, 15.
- (c) Seal, Fine Leak: Not applicable for Variants 01, 02, 05, 06, 09, 10, 13, 14, 15.
- (d) Radiographic Inspection: Not applicable for Variants 01, 02, 05, 06, 09, 10, 13, 14, 15.

2.1.1.3 *Deviations from Qualification and Periodic Tests (Chart F4)*

- (a) Bond Strength: Not applicable for Variants 01, 02, 05, 06, 09, 10, 13, 14, 15.
- (b) Die Shear: Not applicable for Variants 01, 02, 05, 06, 09, 10, 13, 14, 15.

2.2 MARKING

The marking shall be in accordance with the requirements of ESCC Basic Specification No. 21700 and as follows.

The information to be marked on the component shall be:

- (a) Terminal Identification.
- (b) The ESCC qualified components symbol (for ESCC qualified components only).
- (c) The ESCC Component Number.
- (d) Traceability information.

2.3 TERMINAL STRENGTH

The test conditions for Terminal Strength, tested as specified in the ESCC Generic Specification, shall be as follows:

- For Variants 01, 02, 05, 06, 09, 10, 13, 14, 15, Test Condition A with applied force 22.2N and duration 15s.
- For Variants 11,12, as specified in the ESCC Generic Specification.

2.4 ELECTRICAL MEASUREMENTS AT ROOM, HIGH AND LOW TEMPERATURES

Electrical measurements shall be performed at room, high and low temperatures. Consolidated notes are given after the tables.

2.4.1 Room Temperature Electrical Measurements

The measurements shall be performed at $T_{amb}=+22 \pm 3^{\circ}C$.

Characteristics	Symbols	MIL-STD-750 Test Method	Test Conditions	Limits		Units
				Min	Max	
Forward Voltage	V_{F1}	4011	Pulse Method $I_F=3A$, Note 1	-	0.865	V
	V_{F2}	4011	Pulse Method $I_F=4A$, Note 1 Variants 01, 02, 05, 06, 09, 10, 13, 14, 15 Variants 11, 12	- -	0.875 0.9	V
	V_{F3}	4011	Pulse Method $I_F=6A$, Note 1 Variants 01, 02, 05, 06, 09, 10, 13, 14, 15 Variants 11,12	- -	0.925 0.955	V
Reverse Current 1	I_{R1}	4016	DC Method $V_R=V_{RWM}$, Note 2 Variants 01, 02, 05, 06, 09, 10, 13, 14, 15 Variants 11, 12	- -	5 2	μA
Reverse Current 2 (Breakdown Voltage)	I_{R2}	4021	Variants 11, 12 only DC Method $V_R=V_{(BR)}$, Note 2	-	10	μA

Characteristics	Symbols	MIL-STD-750 Test Method	Test Conditions	Limits		Units
				Min	Max	
Breakdown Voltage	$V_{(BR)}$	4021	Variants 01, 02, 05, 06, 09, 10, 13, 14, 15 only Pulse Method $I_R=100\mu A$, Note 1	Note 2	-	V
Capacitance	C	4001	$V_R = 10V$ $V_{sig}=50mV$ (p-p)max $f = 1MHz$	-	60	pF
Reverse Recovery Time	t_{rr}	4031	Variants 01, 02, 05, 06, 09, 10, 13, 14, 15 Test Condition B $I_F = I_R = 1A$ $I_{rr}=100mA(pk)$ $di/dt=100A/\mu s$ (min) Note 3	-	30	ns
			Variants 11, 12 Test Condition B $I_F=1A$ $V_R=30V$ $dI_F/dt=-50A/\mu s$	-	35	ns
Forward Recovery Time	t_{fr}	4026	$I_F=500mA$ $V_{fr}=1.1V_F$	-	15	ns
Forward Recovery Voltage	V_{fr}	4026	$I_F=500mA$	-	2.2	V
Thermal Impedance, Junction to Reference Point	$Z_{th(j-x)}$	3101	Variants 01, 02, 05, 06, 09, 10, 13, 14, 15 $I_H = 30A$ $t_H = 10ms$ $I_M = 10mA$ $t_{MD} = 70\mu s$ max Note 4	(Calculate ΔV_F , see Note 5)		$^{\circ}C/W$
Thermal Impedance, Junction to Case	$Z_{th(j-c)}$	3101	Variants 11, 12 $I_H = 1$ to 10A $t_H = 50ms$ $I_M = 50mA$ $t_{MD} = 100\mu s$ Note 4	(Calculate ΔV_F , see Note 5)		$^{\circ}C/W$

2.4.2 High and Low Temperatures Electrical Measurements

Characteristics	Symbols	MIL-STD-750 Test Method	Test Conditions Note 3	Limits		Units
				Min	Max	
Forward Voltage 2	V _{F2}	4011	T _{amb} =+125(+0 -5)°C Pulse Method I _F =4A, Note 1	-	0.8	V
			T _{amb} =-65(+5 -0)°C Pulse Method I _F =4A, Note 1	-	1.075	V
Reverse Current 1	I _{R1}	4016	T _{amb} =+125(+0 -5)°C DC Method V _R = V _{RWM} , Note 2 Variants 01, 02, 05, 06, 09, 10, 13, 14, 15 Variants 11, 12	-	525	μA
				-	30	
Reverse Current 2 (Breakdown Voltage)	I _{R2}	4021	Variants 11, 12 only T _{amb} = -65(+5 -0)°C DC Method V _R =V _(BR) , Note 2	-	10	μA
Breakdown Voltage	V _(BR)	4021	Variants 01, 02, 05, 06, 09, 10, 13, 14, 15 only T _{amb} = -65(+5 -0)°C Pulse Method I _R =100μA, Note 1	Note 2	-	V

2.4.3 Notes to Electrical Measurement Tables

1. For Variants 01, 02, 05, 06, 09, 10, 13, 14, 15 Pulse Width ≤8.3ms, Duty Cycle ≤2%.
For Variants 11, 12 Pulse Width ≤ 680μs, Duty Cycle ≤ 2%.
2. See Component Type Variants for V_{RWM} and V_(BR) values.
3. Read and record measurements shall be performed on a sample of 5 components with 0 failures allowed. Alternatively a 100% inspection may be performed.
4. Performed only during Screening Tests Parameter Drift Values (Initial Measurements), go-no-go.
5. The limits for ΔV_F shall be defined by the Manufacturer on every lot in accordance with MIL-STD-750 Method 3101 and shall guarantee the R_{th} limits specified in Maximum Ratings.

2.5 PARAMETER DRIFT VALUES

Unless otherwise specified, the measurements shall be performed at T_{amb}=+22 ±3°C.

The test methods and test conditions shall be as per the corresponding test defined in Room Temperature Electrical Measurements.

The drift values (Δ) shall not be exceeded for each characteristic specified. The corresponding absolute limit values for each characteristic shall not be exceeded.

Characteristics	Symbols	Limits		Units	
		Drift Value Δ	Absolute		
			Min		Max
Forward Voltage 2 Variants 01, 02, 05, 06, 09, 10, 13, 14, 15 Variants 11, 12	V_{F2}	± 0.05	-	0.875	V
			-	0.9	
Reverse Current 1 Variants 01, 02, 05, 06, 09, 10, 13, 14, 15 Variants 11, 12	I_{R1}	± 0.5 or (1) $\pm 100\%$	-	5	μA
			-	2	

NOTES:

1. Whichever is the greater referred to the initial value.

2.6

INTERMEDIATE AND END-POINT ELECTRICAL MEASUREMENTS

Unless otherwise specified, the measurements shall be performed at $T_{amb} = +22 \pm 3^{\circ}C$.

The test methods and test conditions shall be as per the corresponding test defined in Room Temperature Electrical Measurements .

Characteristics	Symbols	Limits		Units
		Min	Max	
Forward Voltage 1 (Variants 11, 12 only)	V_{F1}	-	0.865	V
Forward Voltage 2 (Variants 01, 02, 05, 06, 09, 10, 13, 14, 15 only)	V_{F2}	-	0.875	V
Forward Voltage 3 (Variants 11, 12 only)	V_{F3}	-	0.955	V
Reverse Current 1 Variants 01, 02, 05, 06, 09, 10, 13, 14, 15 Variants 11, 12	I_{R1}	-	5	μA
		-	2	

2.7

HIGH TEMPERATURE REVERSE BIAS BURN-IN CONDITIONS

Characteristics	Symbols	Limits	Units
Ambient Temperature	T_{amb}	+150 (+0 -5)	$^{\circ}C$
Reverse Voltage	V_R	$0.8 \times V_{RWM}$ (Note 1)	V
Duration	t	≥ 48	hours

NOTES:

1. See Component Type Variants for V_{RWM} value.

2.8 POWER BURN-IN CONDITIONS

For Variants 01, 02, 05, 06, 09, 10, 13, 14, 15

Characteristics	Symbols	Test Conditions	Units
Ambient Temperature	T_{amb}	+55 maximum	°C
Junction Temperature	T_j	+135 minimum	°C
Reverse Voltage	V_R	V_{RWM} (Note 1)	V
Average Output Rectified Current	I_O	3 minimum (Notes 2, 3)	A

For Variants 11, 12

Characteristics	Symbols	Test Conditions	Units
Ambient Temperature	T_{amb}	+22 ± 3	°C
Junction Temperature	T_j	+175 (+0 -5)	°C
Average Output Rectified Current	I_O	Note 3	A

NOTES:

1. See Component Type Variants for V_{RWM} value.
2. Mounting shall be performed without bending or soldering leads. Lead length from body to mounting shall be 3.14mm minimum.
3. The output current may be adjusted, within the given limit range, to attain the specified junction temperature.

2.9 OPERATING LIFE CONDITIONS

For Variants 01, 02, 05, 06, 09, 10, 13, 14, 15

Characteristics	Symbols	Test Conditions	Units
Ambient Temperature	T_{amb}	+55 maximum	°C
Junction Temperature	T_j	+175 minimum	°C
Reverse Voltage	V_R	V_{RWM} (Note 1)	V
Average Output Rectified Current	I_O	3 minimum (Notes 2, 3)	A

NOTES:

1. See Component Type Variants for V_{RWM} value.
2. Mounting shall be performed without bending or soldering leads. Lead length from body to mounting shall be 3.14mm minimum.
3. The output current may be adjusted, within the given limit range, to attain the specified junction temperature.



For Variants 11, 12
The conditions shall be as specified for Power Burn-in.

APPENDIX 'A'

AGREED DEVIATIONS FOR STMICROELECTRONICS (F)

ITEMS AFFECTED	DESCRIPTION OF DEVIATIONS
Deviations from Production Control-Chart F2	Special In-process Control Internal Visual Inspection. Wedge bonds equal to 1.1 wire diameters are acceptable for bonding with a V-Groove tool.
	Special In-process Control Internal Visual Inspection. For CCP packages the criteria specified for voids in the fillet and minimum die mounting material around the visible die perimeter for die mounting defects may be omitted providing that a radiographic inspection to verify the die-attach process is performed on a sample basis in accordance with STMicroelectronics procedure 7050651.
Deviations from Screening Tests - Chart F3	Solderability is not applicable unless specifically stipulated in the Purchase Order.
Room Temperature Electrical Measurements	<p>All AC characteristics (C, t_{rr}, t_{fr}, V_{fr}) may be considered guaranteed but not tested if successful pilot lot testing has been performed in accordance with STMicroelectronics procedure 7188211 on the wafer lot, which includes AC characteristic measurements per the Detail Specification.</p> <p>A summary of the pilot lot testing shall be provided if required by the Purchase Order.</p>
High and Low Temperatures Electrical Measurements	<p>Low temperature characteristic I_{R2} may be considered guaranteed but not tested if successful pilot lot testing has been performed in accordance with STMicroelectronics procedure 7188211 on the wafer lot, which includes low temperature characteristic measurements per the Detail Specification.</p> <p>A summary of the pilot lot testing shall be provided if required by the Purchase Order.</p>