



**CONNECTORS, ELECTRICAL, RECTANGULAR,  
NANOMINIATURE, NON-REMOVABLE CRIMP  
CONTACTS AND UNINSULATED SOLID WIRE  
CONTACTS**

**BASED ON TYPE NANO-D**

**ESCC Detail Specification No. 3401/086**

Issue 1	May 2013
---------	----------



### **LEGAL DISCLAIMER AND COPYRIGHT**

European Space Agency, Copyright © 2013. All rights reserved.

The European Space Agency disclaims any liability or responsibility, to any person or entity, with respect to any loss or damage caused, or alleged to be caused, directly or indirectly by the use and application of this ESCC publication.

This publication, without prior permission of the European Space Agency and provided it is not used for a commercial purpose, may be:

- copied in whole, in any medium, without alteration or modification.
- copied in part, in any medium, provided that the ESCC document identification, comprising the ESCC symbol, document number and document issue, is removed.

**DOCUMENTATION CHANGE NOTICE**

(Refer to <https://escies.org> for ESCC DCR content)

DCR No.	CHANGE DESCRIPTION

**TABLE OF CONTENTS**

1	GENERAL	6
1.1	SCOPE	6
1.2	COMPONENT TYPE VARIANTS AND RANGE OF COMPONENTS	6
1.3	MAXIMUM RATINGS	6
1.4	PARAMETER DERATING INFORMATION	6
1.5	PHYSICAL DIMENSIONS	6
1.6	CONTACT ARRANGEMENTS	6
2	APPLICABLE DOCUMENTS	6
3	TERMS, DEFINITIONS, ABBREVIATIONS, SYMBOLS AND UNITS	7
4	REQUIREMENTS	21
4.1	GENERAL	21
4.2	DEVIATIONS FROM GENERIC SPECIFICATION	21
4.2.1	Deviations from Special In-Process Controls	21
4.2.2	Deviations from Final Production Tests (Chart II)	21
4.2.3	Deviations from Burn-in and Electrical Measurements (Chart III)	21
4.2.4	Deviations from Qualification Tests (Chart IV)	21
4.2.5	Deviations from Lot Acceptance Tests (Chart V)	22
4.3	MECHANICAL REQUIREMENTS	22
4.3.1	Dimension Check	22
4.3.2	Weight	22
4.3.3	Contact Capability (Applicable to Male Contacts Only)	22
4.3.4	Contact Retention (in Insert)	22
4.3.5	Mating and Unmating Forces	23
4.3.6	Insert Retention (in Shell)	23
4.3.7	Jackscrew Retention	23
4.3.8	Contact Insertion and Withdrawal Forces	23
4.3.9	Engagement and Separation Forces	23
4.3.10	Oversize Pin Exclusion	23
4.3.11	Probe Damage	23
4.3.12	Solderability	23
4.4	MATERIALS AND FINISHES	23
4.4.1	Shells, Backshells	23
4.4.2	Inserts	24
4.4.3	Accessories	24
4.4.4	Contacts	24
4.4.4.1	Female Contacts (Applicable to Variant 02 Only)	24

4.4.4.2	Female Contacts (Applicable to Variants 03 and 04)	24
4.4.4.3	Male Contacts (Applicable to Variants 01 and 02)	24
4.4.5	Insulated Wire (Applicable to Variants 01 and 02)	24
4.4.6	Rear Potting	24
4.5	MARKING	24
4.5.1	General	24
4.5.2	The ESCC Component Number	24
4.5.3	Characteristics	25
4.5.3.1	Characteristics Applicable to Variants 01 and 02 (Jumpers)	25
4.5.3.2	Characteristics Applicable to Variant 03	27
4.5.3.3	Characteristics Applicable to Variant 04	28
4.5.4	Traceability Information	28
4.6	ELECTRICAL MEASUREMENTS	29
4.6.1	Electrical Measurements at Room Temperature	29
4.6.2	Electrical Measurements at High and Low Temperatures (Table 3)	29
4.6.3	Circuits for Electrical Measurements (Figure 4)	29
4.7	BURN-IN AND ELECTRICAL MEASUREMENTS (TABLES 4 AND 5)	29
4.8	ENVIRONMENTAL AND ENDURANCE TESTS (CHARTS IV AND V OF ESCC GENERIC SPECIFICATION NO. 3401)	29
4.8.1	Measurements and Inspections on Completion of Environmental Tests	29
4.8.2	Measurements and Inspections at Intermediate Points During Endurance Tests	29
4.8.3	Measurements and Inspections on Completion of Endurance Tests	30
4.8.4	Conditions for Operating Life (Part of Endurance Testing) (Table 5)	30
4.8.5	Electrical Circuit for Operating Life Test (Figure 5)	30
4.8.6	Conditions for High Temperature Storage Test (Part of Endurance Testing)	30
APPENDIX 'A'		34

## 1 GENERAL

### 1.1 SCOPE

This specification details the ratings, physical and electrical characteristics, test and inspection data for Connectors, Electrical, Rectangular, Nanominiature, with Non-removable Crimp-type Contacts and Uninsulated Solid Wire Contacts, Based on Type Nano-D. It shall be read in conjunction with ESCC Generic Specification No. 3401, the requirements of which are supplemented herein, and ESCC Detail Specification No. 3901/012.

### 1.2 COMPONENT TYPE VARIANTS AND RANGE OF COMPONENTS

The different sizes of the basic connector types and the contact types specified herein, which are also covered by this specification, together with their mechanical characteristics, are scheduled in Table 1(a).

### 1.3 MAXIMUM RATINGS

The maximum ratings, which shall not be exceeded at any time during use or storage, applicable to the connectors specified herein, are scheduled in Table 1(b).

### 1.4 PARAMETER DERATING INFORMATION

The derating information applicable to the connectors specified herein is shown in Figure 1.

### 1.5 PHYSICAL DIMENSIONS

The physical dimensions of the connectors specified herein are shown in Figures 2 and 3. Figure 4 shows the connector mounting.

### 1.6 CONTACT ARRANGEMENTS

The available contact arrangements are shown in Figure 3 and Para. 4.5.3. Para. 4.5.3 also shows the compatible wires and cables.

## 2 APPLICABLE DOCUMENTS

The following documents form part of this specification and shall be read in conjunction with it:

- (a) ESCC Generic Specification No. 3401: Connectors, Electrical, Non-filtered, Circular and Rectangular.
- (b) ESCC Detail Specification No. 3901/012: Extruded, Crosslinked Fluoropolymer Insulated Wires and Cables on Silver Plated Copper Conductor, Low Frequency, 600V, -100 to +200°C.
- (c) MIL-DTL-32139: Connectors, Electrical, Rectangular, Nanominiature, Polarised Shell, General Specification for.
- (d) MIL-M-24519: Moulding Plastics, Electrical, Thermoplastic.
- (e) ASTM-B194: Copper-beryllium Alloy Plate, Sheet, Strip, and Rolled Bar.
- (f) ASTM-B488: Gold for Engineering Use, Electrodeposited Coatings of.
- (g) ASTM-B541: Alloy, Electrical Contact, Gold.
- (h) SAE-AMS-QQ-N-290: Nickel Plating (Electrodeposited).
- (i) ECSS-Q-ST-70-26: Crimping of high-reliability electrical connections.

**3 TERMS, DEFINITIONS, ABBREVIATIONS, SYMBOLS AND UNITS**

For the purpose of this specification, the terms, definitions, abbreviations, symbols and units specified in ESCC Basic specification No. 21300 shall apply. In addition the following terms and abbreviations are used:

(a) Terms

- Jumper: Two connectors (either two plugs or 1 plug and 1 receptacle) of the same number of ways (n), wired together with n wires (per ESCC 3901/012) of the same, specified, length. Length of wire  $\geq$  50mm.
- Potting: Epoxy compound, used as an encapsulant.

(b) Abbreviations

- CBR: Condensed Board Right-angle (describes a type of receptacle).
- SMV: Surface Mount Vertical (describes a type of receptacle).

**TABLE 1(a) – COMPONENT TYPE VARIANTS AND RANGE OF COMPONENTS**

Shell Size (Note 1)	Weight Max (g) (Notes 2, 3)				Mating and Unmating Forces (N)	
	Variant 01 PP Jumper (Note 4)	Variant 02 PS Jumper (Note 5)	Variant 03 CBR Type (Note 6)	Variant 04 SMV Type (Note 7)	Mating (Max.)	Unmating (Min.)
09	3.8	3.8	1	0.4	17.55	0.99
15	6.2	6.2	1.1	0.5	29.25	1.65
21	7.4	7.4	1.2	0.6	40.95	2.31
25	8.8	8.8	1.4	0.7	48.75	2.75
37	12.9	12.9	1.8	1.1	72.15	4.07
51	17.3	17.3	2.4	1.7	99.45	5.61

**NOTES:**

1. See Figures 2.1, 2.3 and 2.4.
2. For Variants 01 and 02 the specified weight includes the connectors and all their associated contacts and accessories, and wires of type ESCC 390101201B, all 50mm in length (Variant 01 of ESCC 3901/012 weighs 0.98g/m). The weights specified allow for either jackscrew type (see Figure 2.2 and Para. 4.5.3.1). The maximum weight of the optional backshell is specified in Para. 4.3.2 herein.
3. For Variants 03 and 04 the weight includes the connector and all its associated contacts and accessories.
4. Variant description: Jumper, PP (2 2-row plugs), fitted with male non-removable crimp contacts.
5. Variant description: Jumper, PS (1 2-row plug and 1 2-row receptacle), fitted with male (in plug) and female (in receptacle) non-removable crimp contacts.
6. Variant description: CBR Type 2-row PCB receptacle, fitted with right-angled contacts.
7. Variant description: SMV Type 2-row PCB receptacle, fitted with vertical surface mount contacts.

**TABLE 1(b) – MAXIMUM RATINGS**

No.	Characteristics	Symbols	Maximum Ratings	Units	Remarks
1	Rated Working Voltage	$U_R$	250	Vrms	Note 1
2	Rated Current	$I_R$	1	A	Note 2
3	Operating Temperature Range	$T_{op}$	-55 to +150	°C	$T_{amb}$
4	Storage Temperature Range	$T_{stg}$	-55 to +150	°C	-
5	Mating Torque	$T_{qe}$	0.12	Nm	Note 3
6	Soldering Temperature	$T_{sol}$	+260	°C	PCB Contacts

**NOTES:**

1. At sea level. Requires derating at altitudes above sea level. See Figure 1.
2. Applies to PCB contact tails and wires per ESCC 3901/012, Variants 01 and 51.
3. To avoid the risk of damaging the jackscrews, for electrical testing, the mating torque shall be 0.08Nm. The minimum in-service mating torque is 0.1Nm.

**FIGURE 1 – PARAMETER DERATING INFORMATION**  
RATED WORKING VOLTAGE VERSUS ALTITUDE

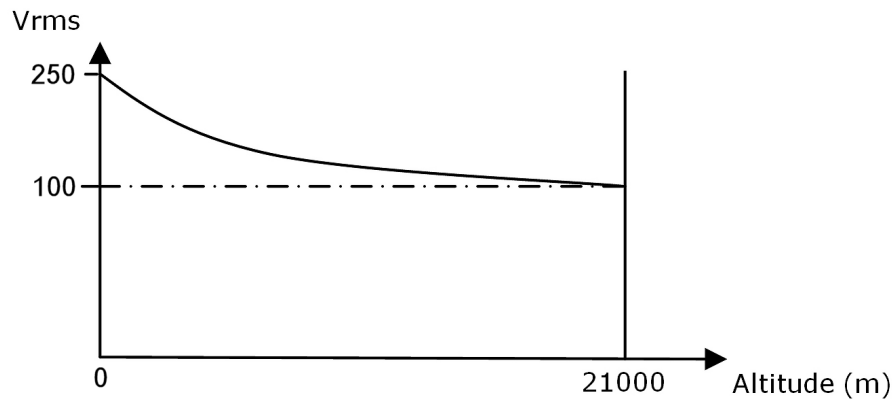
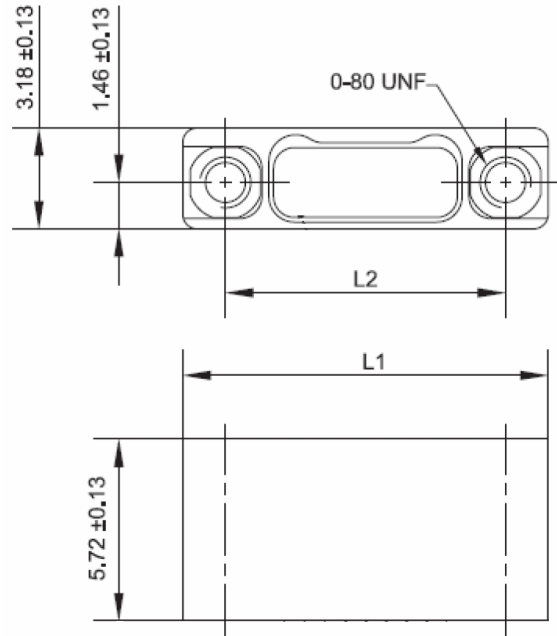



**FIGURE 2 – PHYSICAL DIMENSIONS**

(all dimensions are in millimetres)

**FIGURE 2.1(a) – JUMPER CONNECTOR SHELLS – RECEPTACLE**



Shell Size	Dimension L1		Dimension L2	
	Min	Max	Min	Max
09	9.4	9.66	6.73	6.99
15	11.3	11.56	8.63	8.89
21	13.21	13.47	10.54	10.8
25	14.48	14.74	11.81	12.07
37	18.29	18.55	15.62	15.88
51	22.73	22.99	20.06	20.32

**FIGURE 2.1(b) – JUMPER CONNECTOR SHELLS – PLUG (NOTE 1)**

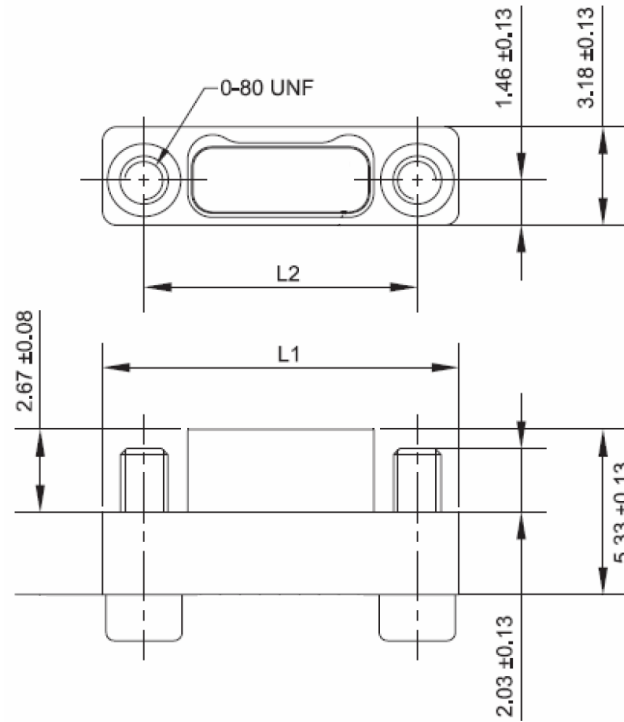

Shell Size	Dimension L1		Dimension L2	
	Min	Max	Min	Max
09	9.4	9.66	6.73	6.99
15	11.3	11.56	8.63	8.89
21	13.21	13.47	10.54	10.8
25	14.48	14.74	11.81	12.07
37	18.29	18.55	15.62	15.88
51	22.73	22.99	20.06	20.32

**NOTES:**

1. Example with non-removable jackscrews is shown. Plugs are also available with retractable jackscrews, see Figure 2.2 and Para. 4.5.3.1.

FIGURE 2.1(c) – JUMPER CONNECTOR SHELLS – PLUG WITH BACKSHELL

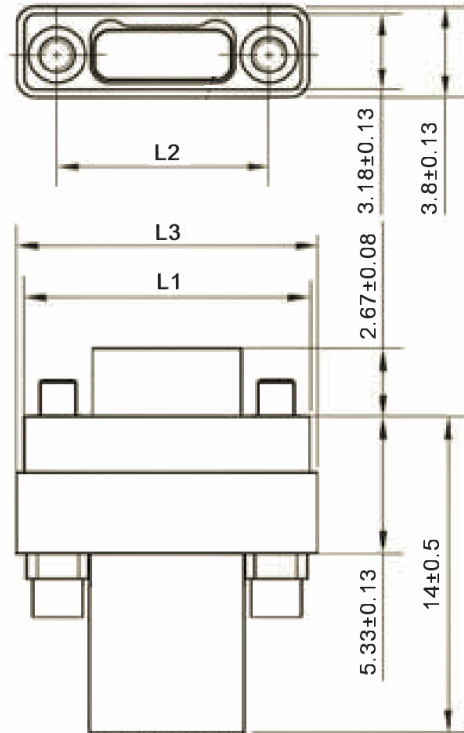

Shell Size	Dimension L1		Dimension L2		Dimension L3	
	Min	Max	Min	Max	Min	Max
09	9.4	9.66	6.73	6.99	10.03	10.29
15	11.3	11.56	8.63	8.89	11.93	12.19
21	13.21	13.47	10.54	10.8	13.84	14.1
25	14.48	14.74	11.81	12.07	15.11	15.37
37	18.29	18.55	15.62	15.88	18.92	19.18
51	22.73	22.99	20.06	20.32	23.36	23.62

**FIGURE 2.2 – JUMPER HARDWARE AND WIRING (VARIANTS 01, 02)**

**Variant 01: PP Jumper**

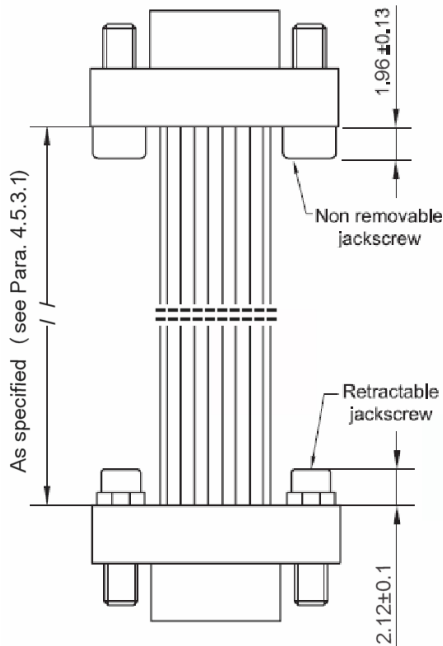

**Variant 02: PS Jumper (Note 1)**

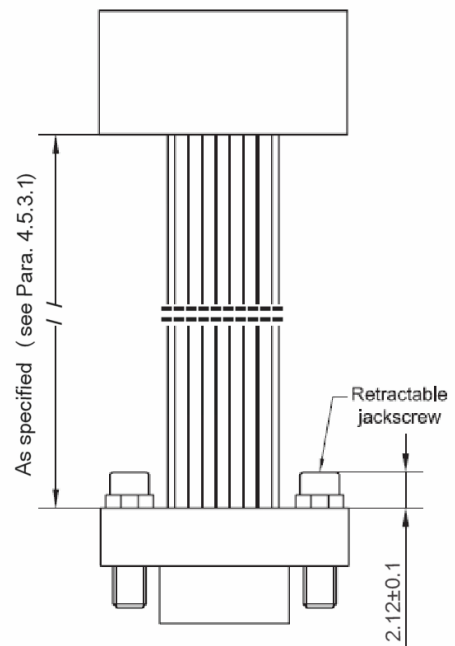

**Variant 01: PP Jumper with Optional Backshell (Note 1)**

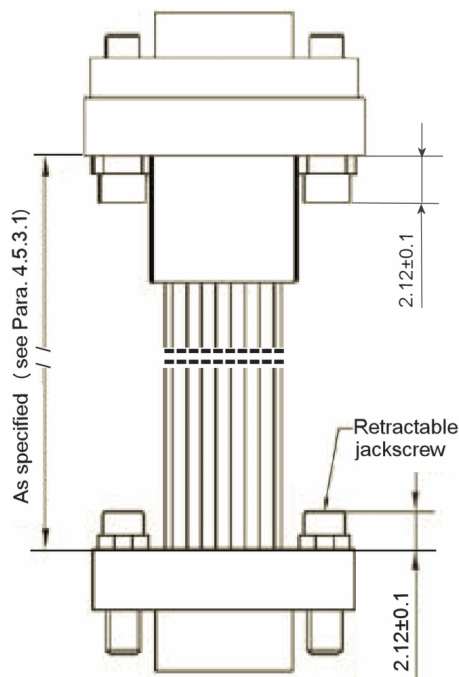

**NOTES:**

1. Although not shown, Variant 01 may be specified with a backshell fitted to each plug and Variant 02 may be specified with a backshell fitted to the plug. See Para. 4.5.3.1.

**FIGURE 2.3 – CBR TYPE RECEPTACLE (VARIANT 03)**

(Shell size 15 is shown for illustrative purposes only)

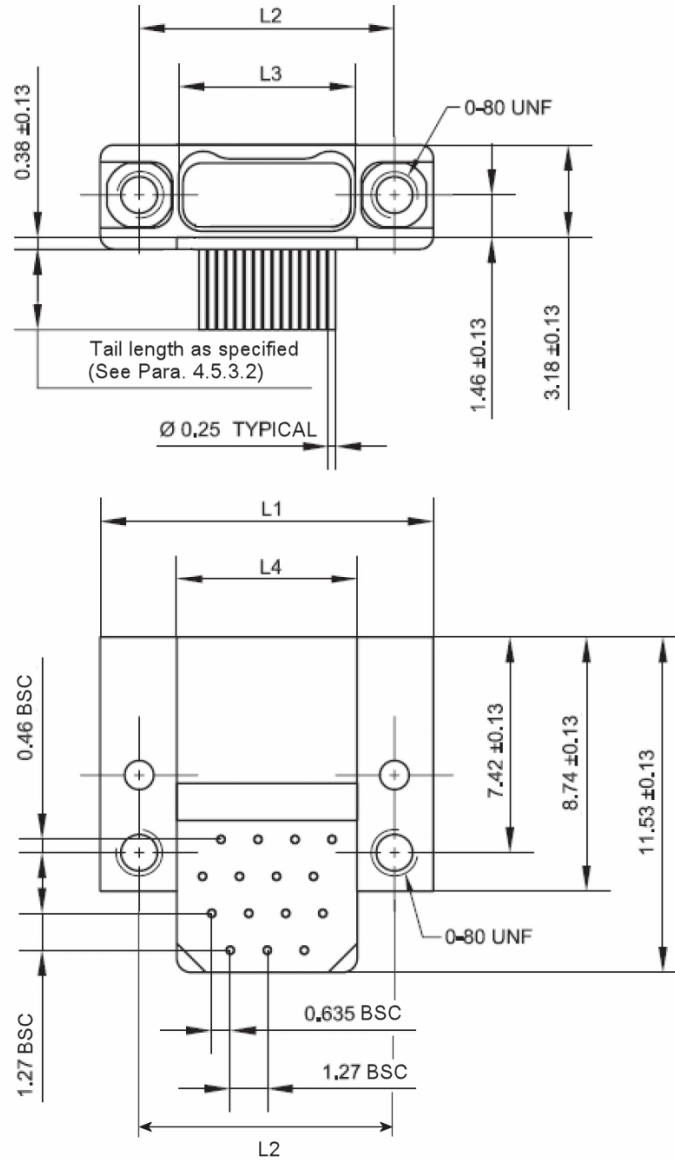

Shell Size	Dimensions							
	L1		L2		L3		L4	
	Min	Max	Min	Max	Min	Max	Min	Max
09	9.4	9.66	6.73	6.99	4.01	4.27	4.19	4.45
15	11.3	11.56	8.63	8.89	5.92	6.18	6.09	6.35
21	13.21	13.47	10.54	10.8	7.82	8.08	8	8.26
25	14.48	14.74	11.81	12.07	9.09	9.35	9.27	9.53
37	18.29	18.55	15.62	15.88	12.9	13.16	13.08	13.34
51	22.73	22.99	20.06	20.32	17.35	17.61	17.52	17.78

**FIGURE 2.4 – SMV TYPE RECEPTACLE (VARIANT 04)**

(Shell size 15 is shown for illustrative purposes only)

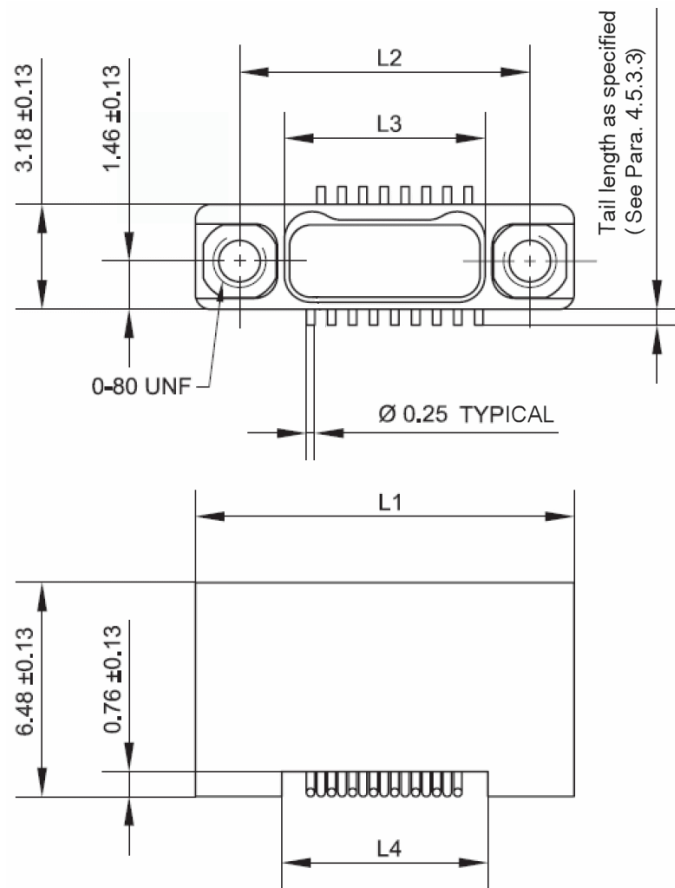

Shell Size	Dimensions							
	L1		L2		L3		L4	
	Min	Max	Min	Max	Min	Max	Min	Max
09	9.4	9.66	6.73	6.99	4.01	4.27	4.19	4.45
15	11.3	11.56	8.63	8.89	5.92	6.18	6.09	6.35
21	13.21	13.47	10.54	10.8	7.82	8.08	8	8.26
25	14.48	14.74	11.81	12.07	9.09	9.35	9.27	9.53
37	18.29	18.55	15.62	15.88	12.9	13.16	13.08	13.34
51	22.73	22.99	20.06	20.32	17.35	17.61	17.52	17.78

**FIGURE 3 – CONTACT ARRANGEMENTS AND SPACING**

**FIGURE 3.1 – MATING FACE OF THE PLUG'S INSERT (USE MIRROR VIEW FOR THE MATING FACE OF THE RECEPTACLE'S INSERT)**

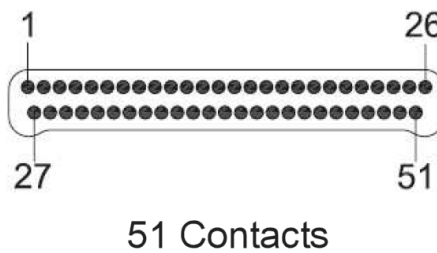
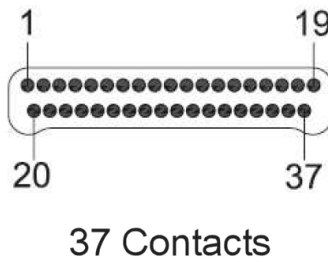
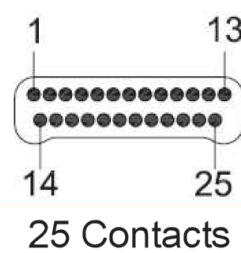
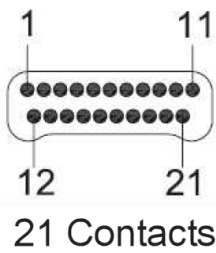
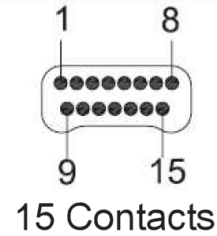
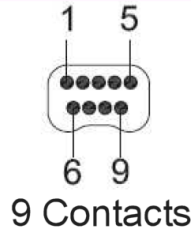

**NOTES:**

1. Only the outside contact cavities on each row are identified in the drawings, the remaining cavities are sequentially numbered.
2. The spacing between contact centres (adjacent contacts on the same row) is 0.635mm typical.
3. The spacing between the row centrelines is 1.016mm typical.

**FIGURE 3.2 – CBR TYPE RECEPTACLE (VARIANT 03)  
PCB TAIL ARRANGEMENTS AND SPACING (VIEWING THE TOP OF THE RECEPTACLE)**

(all dimensions are in millimetres)

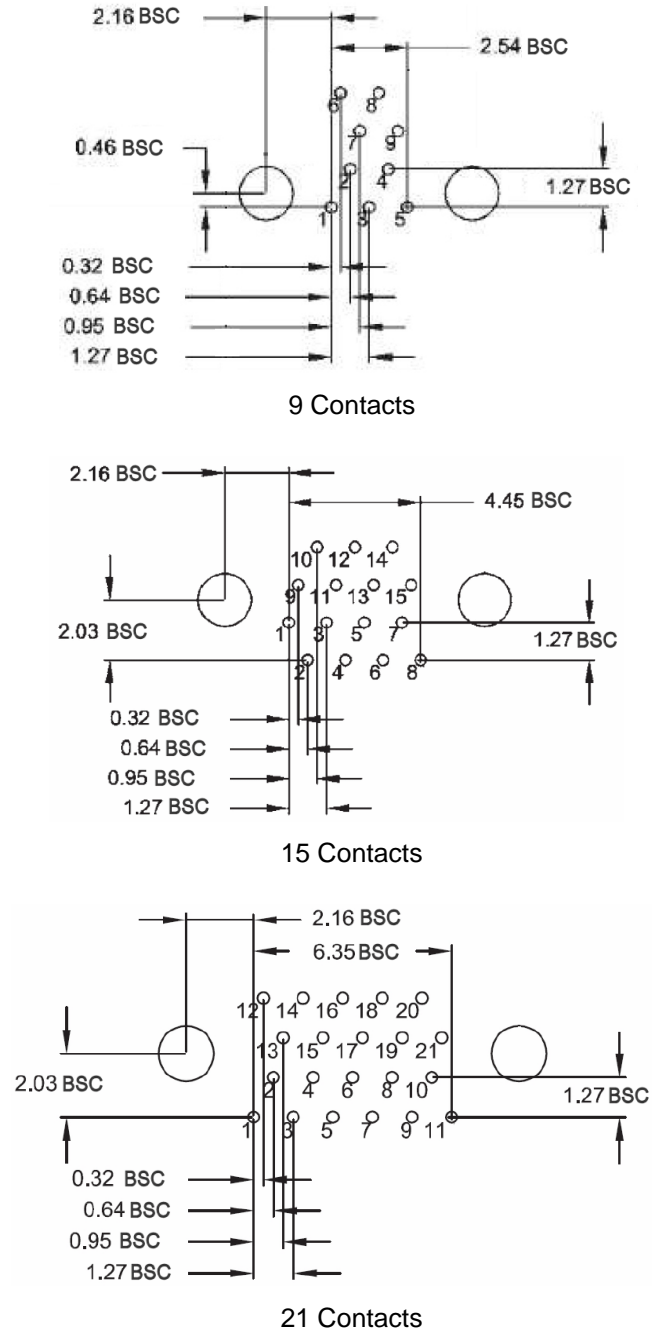



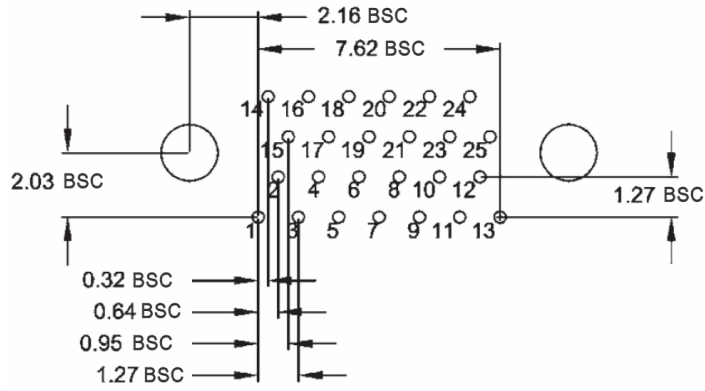

25 Contacts

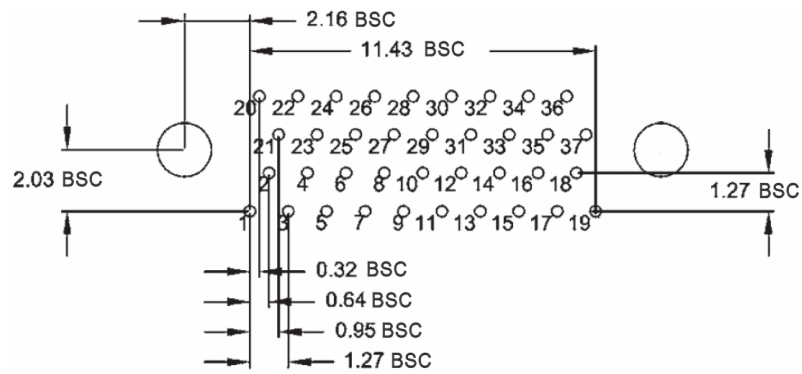

37 Contacts

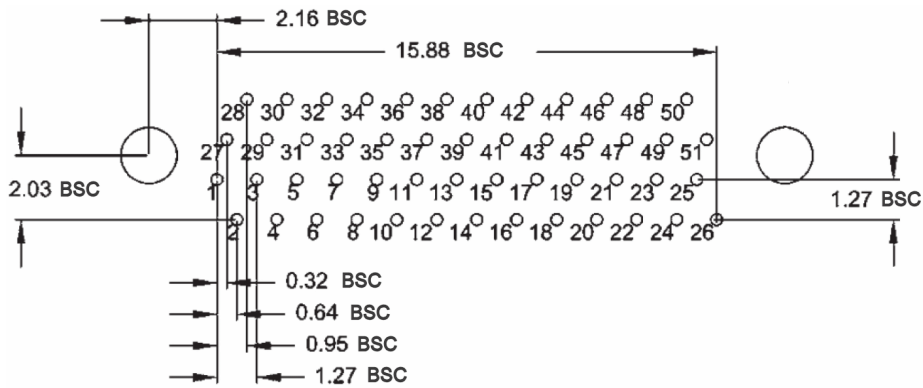

51 Contacts

**FIGURE 3.3 – SMV TYPE RECEPTACLE (VARIANT 04)  
PCB TAIL ARRANGEMENTS AND SPACING (VIEWING THE BOTTOM FACE OF THE RECEPTACLE)**

(all dimensions are in millimetres)

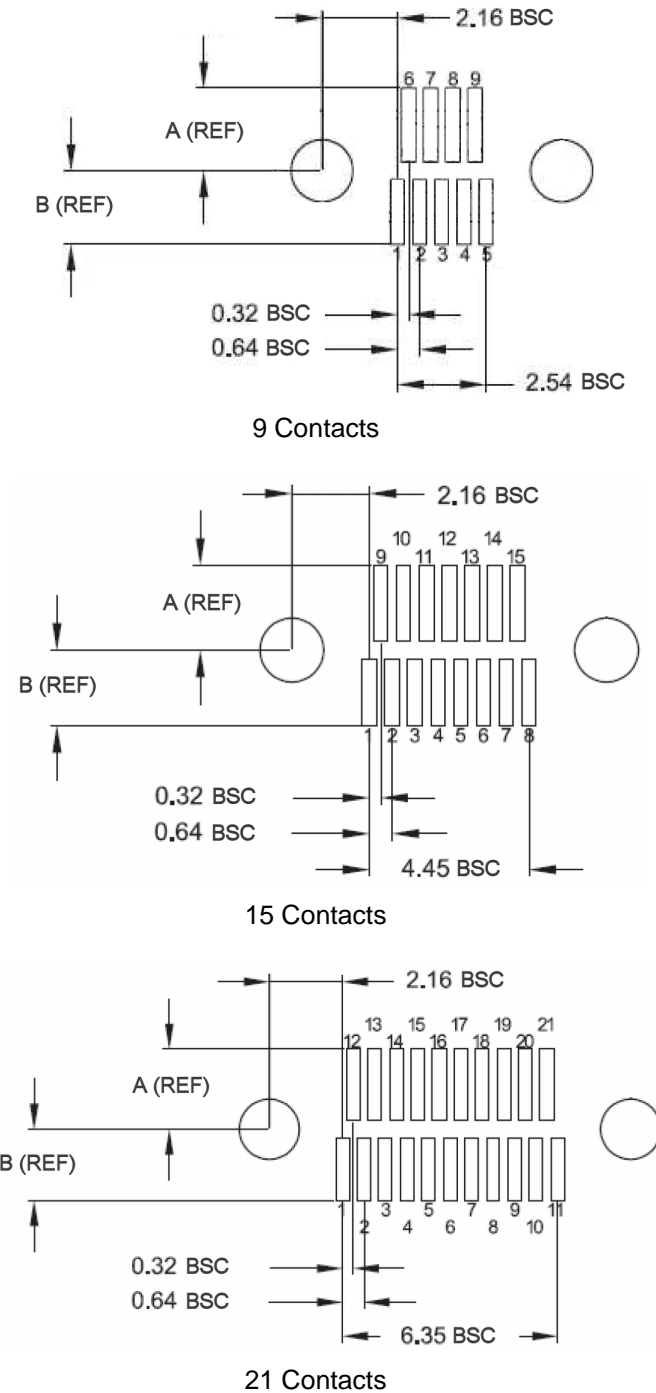

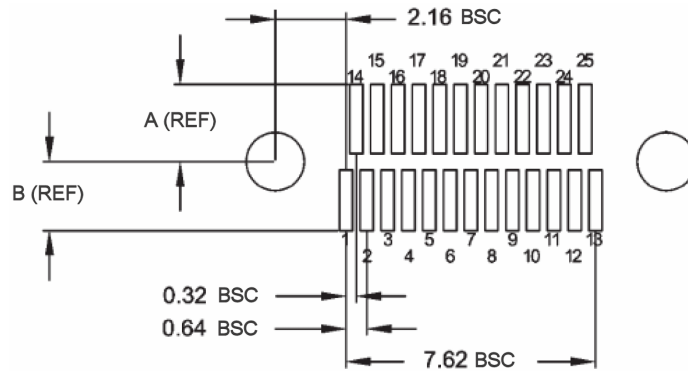

25 Contacts

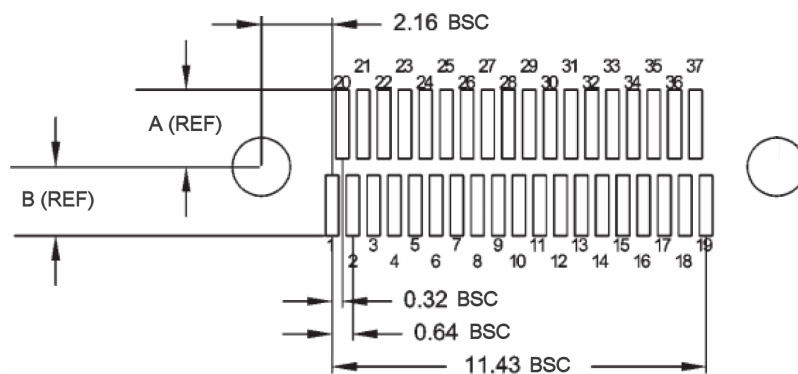

37 Contacts

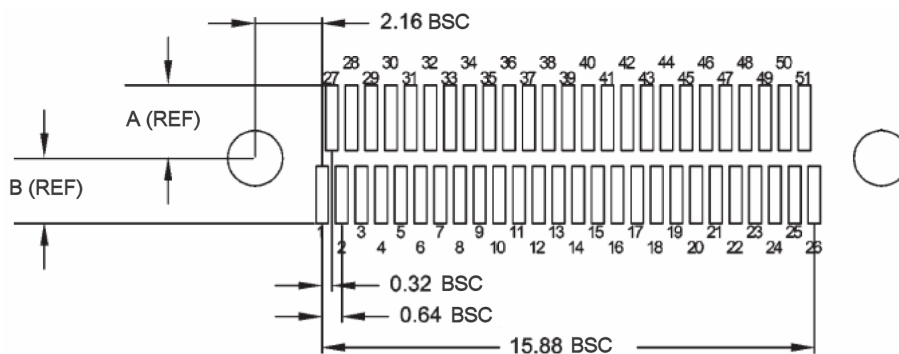

51 Contacts

Symbols	Standard Tail Length (see Para. 4.5.3.3)	Longer Tail Length (see Para. 4.5.3.3)
A	2.36	2.56
B	2.11	2.31

**FIGURE 4 – CONTACT POSITIONS**

**FIGURE 4.1 – MOUNTING CONDITION**

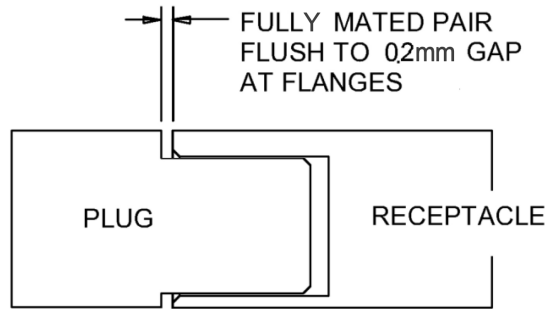

**FIGURE 4.2 – PLUG MALE CONTACT**

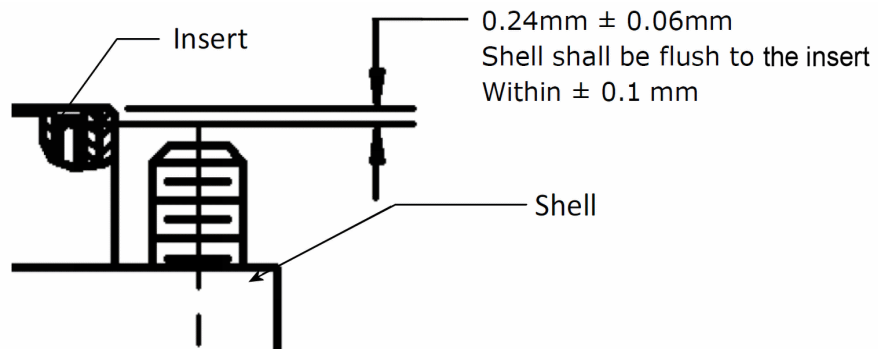

**FIGURE 4.3 – RECEPTACLE FEMALE CONTACT**

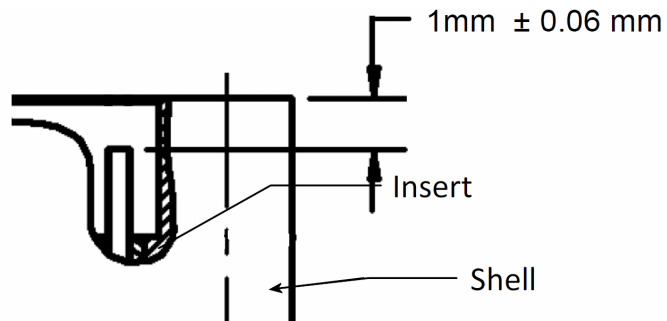

## 4 REQUIREMENTS

### 4.1 GENERAL

The complete requirements for procurement of the components specified herein shall be as stated in this specification and ESCC Generic Specification No. 3401. Deviations from the Generic Specification, applicable to this specification only, are detailed in Para 4.2.

Deviations from the Generic Specification and this Detail Specification, formally agreed with specific Manufacturers on the basis that the alternative requirements are equivalent to the ESCC requirements and do not affect the components' reliability, are listed in the appendices attached to this specification.

### 4.2 DEVIATIONS FROM GENERIC SPECIFICATION

#### 4.2.1 Deviations from Special In-Process Controls

- (a) Para. 5.2.4, Crimping Capability: The test shall be performed on Variants 01 and 02 only in accordance with ECSS-Q-ST-70-26 during assembly. The wire used shall be ESCC 3901/012 Variant 01 and the minimum tensile strength of the wire is 1N.

#### 4.2.2 Deviations from Final Production Tests (Chart II)

- (a) Para. 9.1.1.1, Insulation Resistance: The test voltage shall be 250Vrms.
- (b) Para. 9.1.1.3, Contact Resistance:
- (c) For Variants 03 and 04, the resistance is measured per MIL-DTL-32139 Para. 4.7.9. 152.4 ± 3mm of ESCC 3901/012 Variant 01 wire is used.
- (d) For Variants 01 and 02, the resistance must be deduced from the length of cable as per ESCC 3401 Para. 9.1.1.3, Figure I(a).
- (e) Para. 9.4, Contact Capability: Only applicable to male contacts.
- (f) Para. 9.9, Seal Test: Not applicable.
- (g) Para. 9.8, Installation of Contacts into Insert: Not applicable.
- (h) Para. 9.5, Magnetism Level: Not applicable.
- (i) Additional Radiographic Inspection: Jumpers shall be subjected to the radiographic inspection of each connector (100% test).

#### 4.2.3 Deviations from Burn-in and Electrical Measurements (Chart III)

Chart III is not applicable.

#### 4.2.4 Deviations from Qualification Tests (Chart IV)

- (a) Para. 9.1.1.1, Insulation Resistance: The test voltage shall be 250Vrms.
- (b) Para. 9.1.1.3, Contact Resistance:
- (c) For Variants 03 and 04, the resistance is measured per MIL-DTL-32139 Para. 4.7.9. 152.4 ± 3mm of ESCC 3901/012 Variant 01 wire is used.
- (d) For Variants 01 and 02, the resistance must be deduced from the length of cable as per ESCC 3401 Para. 9.1.1.3, Figure I(a).
- (e) Para. 9.9, Seal Test: Not applicable.
- (f) Para. 9.14, Plating Thickness: Only applicable to female contacts.
- (g) Para. 9.17, Contact Retention (in Insert): Only applicable to female contacts.
- (h) Para. 9.18, Endurance: The number of cycles shall be 200.
- (i) Para. 9.27, Maintenance Aging: Not applicable.

4.2.5 Deviations from Lot Acceptance Tests (Chart V)

- (a) Para. 9.1.1.1, Insulation Resistance: The test voltage shall be 250Vrms.
- (b) Para. 9.1.1.3, Contact Resistance:
- (c) For Variants 03 and 04, the resistance is measured per MIL-DTL-32139 Para. 4.7.9. 152.4 ± 3mm of ESCC 3901/012 Variant 01 wire is used.
- (d) For Variants 01 and 02, the resistance must be deduced from the length of cable as per ESCC 3401 Para. 9.1.1.3, Figure I(a).
- (e) Para. 9.9, Seal Test: Not applicable.
- (f) Para. 9.17, Contact Retention (in Insert): Only applicable to female contacts.
- (g) Para. 9.18, Endurance: The number of cycles shall be 50.
- (h) Para. 9.27, Maintenance Aging: Not applicable.

4.3 MECHANICAL REQUIREMENTS

4.3.1 Dimension Check

The dimensions of the connectors specified herein shall be verified in accordance with the requirements set out in Para. 9.6 of ESCC Generic Specification No. 3401 and shall conform to those shown in Figures 2 and 3 of this specification.

4.3.2 Weight

The maximum weights of the connectors and their associated contacts and accessories specified herein are specified in Table 1(a).

The maximum weight of the optional backshell is shown below.

Shell Size	Maximum weight of one backshell (g) Note 1
09	0.4
15	0.5
21	0.55
25	0.6
37	0.7
51	0.85

**NOTES:**

1. For Variant 01 (PP Jumper), the weight of two backshells may need to be taken into account. See Para. 4.5.3.1.

4.3.3 Contact Capability (Applicable to Male Contacts Only)

For the purpose of this test, the pick-up and drop weights shall be as follows:

Measurements	Pick-Up Weight	Drop Weight
Weight (g)	10	80
Inner Gauge Diameter (mm)	0.337 – 0.342	0.322 – 0.327
Insertion Depth (mm)	≥ 1.15	≥ 1.15

4.3.4 Contact Retention (in Insert)

Contact retention within the insert shall be 2.2N minimum. There shall be no displacement of the contact.

#### 4.3.5 Mating and Unmating Forces

The forces applied for the mating and unmating of the connectors shall conform to the values specified in Table 1(a).

#### 4.3.6 Insert Retention (in Shell)

The connector inserts shall withstand a pressure of 34.4N/cm<sup>2</sup> applied from the mating side to the rear side.

#### 4.3.7 Jackscrew Retention

Jumpers supplied with non-removable jackscrews (see Para. 4.5.3.1) shall be subjected to a jackscrew retention test. The conditions are as follows:

- Test load: ≤ 40N.
- Rate of increase of load: 1N/s.
- Period of application of test load: 10s.

#### 4.3.8 Contact Insertion and Withdrawal Forces

Not applicable.

#### 4.3.9 Engagement and Separation Forces

The engagement and separation forces of the male twist-pin contacts are measured as follows:

- The contacts are engaged and separated 3 times with a minimum diameter (0.317mm ± 0.005mm) test sleeve.
- The engagement forces shall be recorded during the third cycle.
- The separation forces shall then be recorded using a maximum diameter (0.332mm ± 0.005mm) test sleeve.

Engagement force: 1.39N maximum.

Separation force: 0.11N minimum.

#### 4.3.10 Oversize Pin Exclusion

Not applicable.

#### 4.3.11 Probe Damage

Not applicable.

#### 4.3.12 Solderability

Not applicable to Variants 01 and 02.

### 4.4 MATERIALS AND FINISHES

The materials and finishes shall be as specified herein. Where a definite material is not specified, a material which will enable the connectors specified herein to meet the performance requirements of this specification shall be used. Acceptance or approval of any constituent material does not guarantee acceptance of the finished product.

#### 4.4.1 Shells, Backshells

Shells and backshells shall be made of aluminium alloy. The plating shall be 15µm minimum of electroless nickel.

#### 4.4.2 Inserts

Inserts shall be made of glass-fibre-filled liquid crystal polymer in accordance with MIL-M-24519.

#### 4.4.3 Accessories

Accessories (Jackscrews, Jackposts, Retainers) shall be made of passivated stainless steel, type 303.

#### 4.4.4 Contacts

##### 4.4.4.1 *Female Contacts (Applicable to Variant 02 Only)*

The contacts shall be made of either 18K gold alloy in accordance with ASTM-B541 or beryllium copper in accordance with ASTM-B194. The plating shall be gold, electrodeposited, in accordance with ASTM-B488, Type II, Class 1 (1.27 $\mu$ m minimum), Code C, over nickel underplate in accordance with SAE-AMS-QQ-N-290 Class 2 (1.27 $\mu$ m to 3.81 $\mu$ m).

##### 4.4.4.2 *Female Contacts (Applicable to Variants 03 and 04)*

The contacts shall be made of beryllium copper or leaded brass alloy CuZn9Pb2. The female contact end shall be plated with a minimum of 1.27 $\mu$ m gold in accordance with ASTM-B488 Type II, Code C, with nickel underplating in accordance with SAE-AMS-QQ-N-290, Rev. A, Class 1 (1.27 $\mu$ m minimum). The uninsulated solid wire PCB tail shall be plated with tin-lead alloy 63/37 (1 $\mu$ m minimum).

##### 4.4.4.3 *Male Contacts (Applicable to Variants 01 and 02)*

Male contacts shall be twist-pin contacts. The contact bundle shall consist of strands of gold alloy in accordance with ASTM-B541. The contact body shall be made of gold.

#### 4.4.5 Insulated Wire (Applicable to Variants 01 and 02)

The materials and finishes of the insulated wire used (single wire: ESCC 3901/012, Variant 01 and shielded twisted pair: ESCC 3901/012, Variant 51) shall be in accordance with the requirements specified in Para. 4.4 of ESCC Detail Specification No. 3901/012.

#### 4.4.6 Rear Potting

The rear potting shall be made of epoxy resin.

### 4.5 MARKING

#### 4.5.1 General

The marking of all components delivered to this specification shall be in accordance with the requirements of ESCC Basic Specification No. 21700 and the following paragraphs. The primary packaging of each component shall be marked in respect of:

- (a) The ESCC Component Number.
- (b) Characteristics.
- (c) Traceability Information.

#### 4.5.2 The ESCC Component Number

The ESCC Component Number shall be constituted and marked as follows:

340108601B

- Detail Specification Number: 3401086
- Type Variant Number (see Table 1(a)): 01
- Testing Level: B



4.5.3 Characteristics

4.5.3.1 *Characteristics Applicable to Variants 01 and 02 (Jumpers)*

The information shall be constituted and marked as follows (example): 25 PP I W1 9 50 L L

- Shell Size (as applicable): 25
- Jumper Type: PP
- Wiring Method: I
- Wire Type: W1
- Wire Colour: 9
- Length of Wire (in cm): 50
- Hardware for 1<sup>st</sup> Connector: L
- Hardware for 2<sup>nd</sup> Connector: L

4.5.3.1.1 Shell Size

The shell size signifies the number of contacts. Shell sizes 09, 15, 21, 25, 37 and 51 are available.

4.5.3.1.2 Jumper Type

PP is mandatory marking for Variant 01 and PS is mandatory marking for Variant 02.

4.5.3.1.3 Wiring Method

Two wiring methods are available; they are codified and indicated as follows:

Code Letter	Wiring Method
I	Indirect Wiring
D	Direct Wiring

Note that indirectly-wired PP Jumpers and directly-wired PS Jumpers have straight, “flat”, wiring and therefore have no cross-overs. The table below details the wiring configurations for indirectly-wired PP Jumpers:

Shell Size	Connector	Pin Numbers																			
		1	2	3	4	5	6	7	8	9	10	11	12	13	14	15	16	17	18	19	20
9	1st Connector	1	2	3	4	5	6	7	8	9	X	X	X	X	X	X	X	X	X	X	X
	2nd Connector	5	4	3	2	1	9	8	7	6	X	X	X	X	X	X	X	X	X	X	X
15	1st Connector	1	2	3	4	5	6	7	8	9	10	11	12	13	14	15	X	X	X	X	X
	2nd Connector	8	7	6	5	4	3	2	1	15	14	13	12	11	10	9	X	X	X	X	X
21	1st Connector	1	2	3	.	.	9	10	11	12	13	14	.	.	19	20	21	X	X	X	X
	2nd Connector	11	10	9	.	.	3	2	1	21	20	19	.	.	14	13	12	X	X	X	X
25	1st Connector	1	2	3	.	.	11	12	13	14	15	16	.	.	23	24	25	X	X	X	X
	2nd Connector	13	12	11	.	.	3	2	1	25	24	23	.	.	16	15	14	X	X	X	X
37	1st Connector	1	2	3	.	.	17	18	19	20	21	22	.	.	35	36	37	X	X	X	X
	2nd Connector	19	18	17	.	.	3	2	1	37	36	35	.	.	22	21	20	X	X	X	X
51	1st Connector	1	2	3	.	.	24	25	26	27	28	29	.	.	49	50	51	X	X	X	X
	2nd Connector	26	25	24	.	.	3	2	1	51	50	49	.	.	29	28	27	X	X	X	X

4.5.3.1.4 Wire Type

Two wire types are available; they are codified and indicated as follows:

Code	Description of Wire Type
W1	Single wire per ESCC 3901/012, Variant 01
W2	Two shielded twisted pairs per ESCC 3901/012, Variant 51, with the remaining wiring being single wire per ESCC 3901/012, Variant 01

Jumper Wiring For Wire Type Code W2

(shown viewing the mating face of the receptacle)

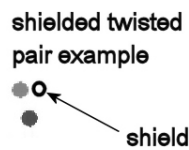
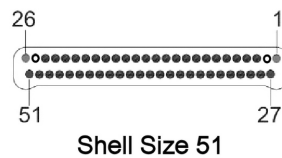
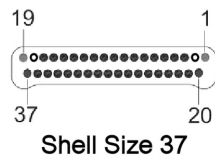
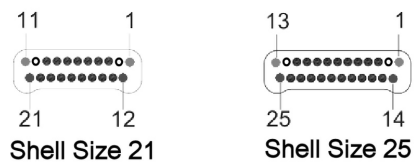
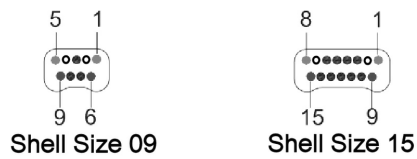

4.5.3.1.5 Wire Colour

All wires each Jumper shall be supplied in one of four colours, specified by means of the following codes:

Code	Colour
9	White
0	Black
1	Brown
2	Red

4.5.3.1.6 Length of Wire

A wire length must be specified, in centimetres, and must be 5cm or longer. The tolerance on the length (L) is as follows:

- $5 \leq L \leq 10$ : -0 / +0.5cm
- $10 < L \leq 100$ : -0 / +3cm
- $L > 100$ : -0 / +5cm

4.5.3.1.7 Hardware for 1<sup>st</sup> Connector

The hardware to be supplied with the 1<sup>st</sup> connector of the Jumper (plug) shall be specified by means of the following codes:

Code Letter	Description of Hardware
L	Non-removable jackscrews, #0-80 UNF, with hex socket head
R	Retractable jackscrews, #0-80 UNF, with hex socket head
V	Retractable jackscrews, #0-80 UNF, with hex socket head plus a backshell (for pre-tensioning)

4.5.3.1.8 Hardware for 2<sup>nd</sup> Connector

The hardware to be supplied with the 2nd connector of the Jumper shall be specified by means of the following codes:

Code Letter	Connector Gender	Description of Hardware
L	Plug	Non-removable jackscrews, #0-80 UNF, with hex socket head
R	Plug	Retractable jackscrews, #0-80 UNF, with hex socket head
V	Plug	Retractable jackscrews, #0-80 UNF, with hex socket head plus a backshell (for pre-tensioning)
P	Receptacle	Threaded inserts (non-removable jackposts), #0-80 UNF

4.5.3.2 *Characteristics Applicable to Variant 03*

The information shall be constituted and marked as follows (example): 25 S CBR P T 1

- Shell Size (as applicable): 25
- Code for Receptacle: S
- Receptacle Type: CBR
- Hardware: P
- Tail Plating: T
- Tail Length: 1

4.5.3.2.1 Shell Size

The shell size signifies the number of contacts. Shell sizes 09, 15, 21, 25, 37 and 51 are available.

4.5.3.2.2 Code for Receptacle

The code letter S indicates that the connector is a receptacle.

4.5.3.2.3 Receptacle Type

The receptacle type is CBR (see Table 1(a), Variant 03).

4.5.3.2.4 Hardware

The code letter P signifies the receptacle has threaded inserts (non-removable jackposts) #0-80 UNF. Note that the receptacle is also supplied with #0-80 UNF screws, 6.35mm ± 0.1mm long, for PCB mounting.

#### 4.5.3.2.5 Tail Plating

The code letter T signifies the PCB tails are plated with tin-lead alloy (Para. 4.4.4.2 refers).

#### 4.5.3.2.6 Tail Length

Four tail lengths are available; they are codified and indicated as follows:

Code	Tail Length and Tolerance
1	2.77mm $\pm$ 0.38mm
2	3.56mm $\pm$ 0.38mm
3	4.37mm $\pm$ 0.38mm
4	2.29mm $\pm$ 0.38mm

#### 4.5.3.3 Characteristics Applicable to Variant 04

The information shall be constituted and marked as follows (example): 25 S SMV P T 1

- Shell Size (as applicable): 25
- Code for Receptacle: S
- Receptacle Type: SMV
- Hardware: P
- Tail Plating: T
- Tail Length (protrusion): 1

##### 4.5.3.3.1 Shell Size

The shell size signifies the number of contacts. Shell sizes 09, 15, 21, 25, 37 and 51 are available.

##### 4.5.3.3.2 Code for Receptacle

The code letter S indicates that the connector is a receptacle.

##### 4.5.3.3.3 Receptacle Type

The receptacle type is SMV (see Table 1(a), Variant 04).

##### 4.5.3.3.4 Hardware

The code letter P signifies the receptacle has threaded inserts (non-removable jackposts) #0-80 UNF. Note that the receptacle is also supplied with #0-80 UNF screws, 6.35mm  $\pm$  0.1mm long, for PCB mounting.

##### 4.5.3.3.5 Tail Plating

The code letter T signifies the PCB tails are plated with tin-lead alloy (Para. 4.4.4.2 refers).

##### 4.5.3.3.6 Tail Length (protrusion)

Two tail lengths (standard tail length and longer tail length) are available; they are codified and indicated as follows:

Code	Tail Length (protrusion)
1	0.645mm typical each side: Standard Tail Length
2	1.016mm typical each side: Longer Tail Length

#### 4.5.4 Traceability Information

Traceability information shall be marked in accordance with the requirements of ESCC Basic Specification No. 21700.

4.6 ELECTRICAL MEASUREMENTS

4.6.1 Electrical Measurements at Room Temperature

The parameters to be measured at room temperature are scheduled in Table 2. Unless otherwise specified, measurements shall be performed at  $T_{amb} = +22\pm 3^{\circ}\text{C}$ . The mating torque for the jackscrews (where fitted) is given in Table 1(b).

4.6.2 Electrical Measurements at High and Low Temperatures (Table 3)

Not applicable.

4.6.3 Circuits for Electrical Measurements (Figure 4)

Not applicable.

4.7 BURN-IN AND ELECTRICAL MEASUREMENTS (TABLES 4 AND 5)

Not applicable.

**TABLE 2 – ELECTRICAL MEASUREMENTS AT ROOM TEMPERATURE**

No.	Characteristics	Symbols	Test Method and Conditions	Limits		Units
				Min	Max	
1	Insulation Resistance	$R_i$	ESCC 3401, Para. 9.1.1.1 and Para. 4.2 of this spec.	1000	-	$M\Omega$
2	Voltage Proof Leakage Current	$I_L$	ESCC 3401, Para. 9.1.1.2 400Vrms	-	5	mA
3	Mated Shell Conductivity (Voltage Drop)	$V_D$	ESCC 3401, Para. 9.1.1.4	-	10	$m\Omega$
4	Contact Resistance (Low Level Current)	$R_{cl}$	ESCC 3401, Para. 9.1.1.3 and Para. 4.2 of this spec.	-	71	$m\Omega$
5	Contact Resistance (Rated Current)	$R_{cr}$	ESCC 3401, Para. 9.1.1.3 and Para. 4.2 of this spec. (Note 1)	-	71	$m\Omega$

**NOTES:**

1. The test current shall be the rated current specified in Table 1(b).

**TABLES 3, 4 AND 5**

Not applicable.

4.8 ENVIRONMENTAL AND ENDURANCE TESTS (CHARTS IV AND V OF ESCC GENERIC SPECIFICATION NO. 3401)

4.8.1 Measurements and Inspections on Completion of Environmental Tests

The parameters to be measured and inspections to be performed on completion of environmental testing are scheduled in Table 6. Unless otherwise specified, the measurements shall be performed at  $T_{amb} = +22\pm 3^{\circ}\text{C}$ .

4.8.2 Measurements and Inspections at Intermediate Points During Endurance Tests

Not applicable.

- 4.8.3 Measurements and Inspections on Completion of Endurance Tests  
The parameters to be measured and inspections to be performed on completion of endurance testing are scheduled in Table 6. Unless otherwise specified, the measurements shall be performed at  $T_{amb} = +22\pm3^{\circ}\text{C}$ .
- 4.8.4 Conditions for Operating Life (Part of Endurance Testing) (Table 5)  
Not applicable.
- 4.8.5 Electrical Circuit for Operating Life Test (Figure 5)  
Not applicable.
- 4.8.6 Conditions for High Temperature Storage Test (Part of Endurance Testing)  
The requirements for the high temperature storage test are specified in Section 9 of ESCC Generic Specification No. 3401. The conditions for high temperature storage testing shall be the maximum storage temperature specified in Table 1(b) of this specification.

**TABLE 6 – MEASUREMENTS AND INSPECTIONS ON COMPLETION OF ENVIRONMENTAL AND ENDURANCE TESTS**

No.	ESCC Generic Spec. No. 3401		Measurements And Inspections		Symbol	Limits		Unit
	Environmental and Endurance Tests Note 1	Test Method and Conditions	Identification	Conditions		Min	Max	
01	Seal Test	Para. 9.9	Not applicable					
02	Wiring	Para. 9.10	Visual Examination	ESCC No. 20500	-	-	-	
			Contact Resistance (Low Level Current)	Table 2, Item 4	$R_{cl}$	Table 2, Item 4		$m\Omega$
			Contact Resistance (Rated Current)	Table 2, Item 5	$R_{cr}$	Table 2, Item 5		$m\Omega$
			Insulation Resistance	Table 2, Item 1	$R_i$	Table 2, Item 1		$M\Omega$
			Voltage Proof Leakage Current	Table 2, Item 2	$I_L$	Table 2, Item 2		$mA$
03	Vibration	Para. 9.11	<b>Initial Measurements</b>	ESCC 3401 Para. 9.11	$T_{qe}$	Record Values		Nm
			Coupling screw(s) Unlocking Torque					
			<b>During Test</b>			-	-	-
			Monitoring					
			<b>Final Measurements</b>	ESCC No. 20500	$\Delta T_{qe}/T_{qe}$	-30	+30	%
Full Engagement								
Coupling screw(s) Unlocking Torque Drift								
			Visual Examination		-	-	-	

No.	ESCC Generic Spec. No. 3401		Measurements And Inspections		Symbol	Limits		Unit
	Environmental and Endurance Tests Note 1	Test Method and Conditions	Identification	Conditions		Min	Max	
04	Shock	Para. 9.12	<b>Initial Measurements</b> Coupling screw(s) Unlocking Torque  <b>During Test</b> Monitoring  <b>Final Measurements</b> Full Engagement Coupling screw(s) Unlocking Torque Drift Visual Examination	Para. 9.11 of ESCC 3401   ESCC No. 20500	T <sub>qe</sub>  -  ΔT <sub>qe</sub> /T <sub>qe</sub>  -	Record Values  -   -  -30   +30  -   -	Nm  -  %  -	
05	Climatic Sequence	Para. 9.13	<b>Initial Measurements</b> Visual Examination Voltage Proof Leakage Current Insulation Resistance  <b>Dry Heat</b> Insulation Resistance  <b>Low Air Pressure</b> Voltage Proof Leakage Current  <b>Damp Heat</b> Insulation Resistance  <b>Final Measurements</b> Visual Examination Voltage Proof Leakage Current Insulation Resistance	ESCC No. 20500 Table 2, Item 2  Table 2, Item 1  Table 2, Item 1  Table 2, Item 2, except test voltage = 100Vrms  Table 2, Item 1  ESCC No. 20500 Table 2, Item 2  Table 2, Item 1	- I <sub>L</sub>  R <sub>i</sub>  R <sub>i</sub>  I <sub>L</sub>  R <sub>i</sub>  - I <sub>L</sub>  R <sub>i</sub>	-   - Table 2, Item 2  Table 2, Item 1  10   -  Table 2, Item 2  100   -  -   - Table 2, Item 2  Table 2, Item 1	- mA  MΩ  MΩ  mA  MΩ  - mA  MΩ	
06	Plating Thickness	Para. 9.14 & Para. 4.2 of this Spec.	Thickness	-	-	Para. 4.4.4 of this Spec.	μm	
07	Joint Strength	Para. 9.15	Tensile Strength of Crimped Joints	Para. 9.15.3 of ESCC 3401	-	6   -	N	
08	Rapid Change of Temperature	Para. 9.16	<b>During Test</b> Monitoring  <b>Final Measurements</b> Visual Examination Insulation Resistance Voltage Proof Leakage Current	No discontinuities  - Table 2, Item 1 Table 2, Item 2	-  - R <sub>i</sub> I <sub>L</sub>	-   -  -   - Table 2, Item 1 Table 2, Item 2	-  - MΩ mA	
09	Contact Retention (in Insert)	Para. 9.17 & Para. 4.2 of this Spec.	Contact Displacement	-	-	Para. 4.3.4 of this Spec.	N	

No.	ESCC Generic Spec. No. 3401		Measurements And Inspections		Symbol	Limits		Unit
	Environmental and Endurance Tests Note 1	Test Method and Conditions	Identification	Conditions		Min	Max	
10	Endurance	Para. 9.18 & Para. 4.2 of this Spec.	<b>Initial Measurements</b> Visual Examination Contact Resistance (Low Level Current) Mating and Unmating Forces  <b>Final Measurements</b> Mating and Unmating Forces Contact Resistance Drift (Low Level Current) Contact Resistance (Rated Current) Insulation Resistance Voltage Proof Leakage Current	ESCC No. 20500 Table 2, Item 4  Para. 9.20 of ESCC 3401  Para. 9.20 of ESCC 3401  Table 2, Item 4  Table 2, Item 5  Table 2, Item 1 Table 2, Item 2	- $R_{cl}$  - $F$  $\Delta R_{cl}$  $R_{cr}$  $R_i$ $I_L$	-   - Table 2, Item 4  Para. 4.3.5 of this Spec.  Para. 4.3.5 of this Spec.  -5   +5 Table 2, Item 5  Table 2, Item 1 Table 2, Item 2	- $m\Omega$  N  N  $m\Omega$  $m\Omega$  $M\Omega$ $mA$	
11	Permanence of Marking	Para. 9.19	Marking Permanence	Para. 9.19 of ESCC 3401	-	-	-	
12	Mating and Unmating Forces	Para. 9.20	Mating and Unmating Forces	Para. 9.20 of ESCC 3401	F	Para. 4.3.5 of this Spec.	N	
13	High Temperature Storage	Para. 9.21	<b>Initial Measurements</b> Visual Examination Contact Resistance (Low Level Current) Mated Shell Conductivity  <b>Final Measurements</b> Visual Examination Mating and Unmating Forces Contact Resistance Drift (Low Level Current) Contact Resistance (Rated Current) Voltage Proof Leakage Current Insulation Resistance Contact Retention (in Insert)	ESCC No. 20500 Table 2, Item 4  Table 2, Item 3  ESCC No. 20500 Para. 9.20 of ESCC 3401  Table 2, Item 4  Table 2, Item 5  Table 2, Item 2  Table 2, Item 1 Para. 9.17 of ESCC 3401 and Para. 4.2 of this Spec.	- $R_{cl}$  $V_D$  - $F$  $\Delta R_{cl}$  $R_{cr}$  $I_L$  $R_i$ -	-   - Table 2, Item 4  Table 2, Item 3  -   - Para. 4.3.5 of this Spec.  -5   +5 Table 2, Item 5  Table 2, Item 2  Table 2, Item 1 Para. 4.3.4 of this Spec.	- $m\Omega$  $m\Omega$  - N  $m\Omega$  $m\Omega$  $mA$  $M\Omega$ N	



No.	ESCC Generic Spec. No. 3401		Measurements And Inspections		Symbol	Limits		Unit
	Environmental and Endurance Tests Note 1	Test Method and Conditions	Identification	Conditions		Min	Max	
14	Corrosion	Para. 9.22	<b>Initial Measurements</b> Visual Examination Contact Resistance (Low Level Current)	ESCC No. 20500 Table 2, Item 4	- $R_{cl}$	- Table 2, Item 4	- -	- mΩ
			<b>Final Measurements</b> Visual Examination Contact Resistance Drift (Low Level Current)	ESCC No. 20500 Table 2, Item 4	- $\Delta R_{cl}$	- -5	- +5	- mΩ
15	Insert Retention (in Shell)	Para. 9.23 and Para. 4.3.6 of this Spec.	Displacement of the insert	-	-	Para. 4.3.6 of this Spec.		N/cm <sup>2</sup>
16	Jackscrew Retention	Para. 9.24 and Para. 4.3.7 of this Spec.	Retention of Captivated Jackscrews	Para. 9.24 of ESCC 3401	-	Para. 4.3.7 of this Spec.		g
17	High Temperature Measurements	Para. 9.25	Insulation Resistance	Table 2, Item 1	$R_i$	1	-	MΩ
18	Overload Test	Para. 9.26	Internal Temperature Contact Resistance (Rated Current) Insulation Resistance Voltage Proof Leakage Current	- Table 2, Item 5  Table 2, Item 1 Table 2, Item 2	T $R_{cr}$  $R_i$ $I_L$	- Table 2, Item 5  Table 2, Item 1 Table 2, Item 2	+150   	°C mΩ  MΩ mA
19	Maintenance Aging	Para. 9.27 and Para. 4.2 of this Spec.	Not applicable					
20	Engagement and Separation Forces	Para. 9.28 and Para. 4.3.9 of this Spec.	Force	-	F	Para. 4.3.9 of this Spec.		N
21	Oversize Pin Exclusion	Para. 9.29 and Para. 4.3.10 of this Spec.	Not applicable					
22	Probe Damage	Para. 9.30 and Para. 4.3.11 of this Spec.	Not applicable					
23	Solderability	Para. 9.31 and Para. 4.3.12 of this Spec.	Where applicable	Para. 9.31 of ESCC 3401	-	ESCC 3401 Para. 9.31		-

**NOTES:**

1. The tests in this Table refer to either Chart IV or V and shall be used as applicable.

**APPENDIX 'A'**  
**AGREED DEVIATIONS FOR AXON' CABLE SAS (F)**

ITEMS AFFECTED	DESCRIPTION OF DEVIATIONS
Para. 4.3.12	Solderability is not applicable for CBR and SMV Types (Variants 03 and 04).