



Pages 1 to 21

**CONNECTORS, ELECTRICAL, RECTANGULAR,  
MICROMINIATURE, REMOVABLE GAUGE 26 CRIMP  
CONTACTS**

**BASED ON TYPE 8MCG**

**ESCC Detail Specification No. 3401/082**

Issue 3	August 2011
---------	-------------



Document Custodian: European Space Agency - see <https://escies.org>

**LEGAL DISCLAIMER AND COPYRIGHT**

European Space Agency, Copyright © 2011. All rights reserved.

The European Space Agency disclaims any liability or responsibility, to any person or entity, with respect to any loss or damage caused, or alleged to be caused, directly or indirectly by the use and application of this ESCC publication.

This publication, without the prior permission of the European Space Agency and provided that it is not used for a commercial purpose, may be:

- copied in whole, in any medium, without alteration or modification.
- copied in part, in any medium, provided that the ESCC document identification, comprising the ESCC symbol, document number and document issue, is removed.

**DOCUMENTATION CHANGE NOTICE**

(Refer to <https://escies.org> for ESCC DCR content)

DCR No.	CHANGE DESCRIPTION
659	Specification upissued to incorporate editorial and technical changes per DCRs.

**TABLE OF CONTENTS**

<b>1.</b>	<b><u>GENERAL</u></b>	<b>6</b>
1.1	Scope	6
1.2	Component Type Variants and Range of Components	6
1.3	Maximum Ratings	6
1.4	Parameter Derating Information	6
1.5	Physical Dimensions	6
<b>2.</b>	<b><u>APPLICABLE DOCUMENTS</u></b>	<b>6</b>
<b>3.</b>	<b><u>TERMS, DEFINITIONS, ABBREVIATIONS, SYMBOLS AND UNITS</u></b>	<b>6</b>
<b>4.</b>	<b><u>REQUIREMENTS</u></b>	<b>14</b>
4.1	General	14
4.2	Deviations from Generic Specification	14
4.2.1	Deviations from Special In-Process Controls	14
4.2.2	Deviations from Final Production Tests (Chart II)	14
4.2.3	Deviations from Burn-in and Electrical Measurements (Chart III)	14
4.2.4	Deviations from Qualification Tests (Chart IV)	14
4.2.5	Deviations from Lot Acceptance Tests (Chart V)	14
4.3	Mechanical Requirements	14
4.3.1	Dimension Check	14
4.3.2	Weight	14
4.3.3	Contact Capability	15
4.3.4	Contact Retention (in Insert)	15
4.3.5	Mating and Unmating Forces	15
4.3.6	Insert Retention (in Shell)	15
4.3.7	Jackscrew Retention	15
4.3.8	Contact Insertion and Withdrawal Forces	15
4.3.9	Engagement and Separation Forces	15
4.3.10	Oversize Pin Exclusion	15
4.3.11	Probe Damage	15
4.3.12	Solderability	15
4.4	Materials and Finishes	15
4.4.1	Shells	15
4.4.2	Inserts	16
4.4.3	Contacts	16
4.4.4	Accessories	16
4.4.5	Magnetism Level	16
4.5	Marking	16
4.5.1	General	16
4.5.2	Contact Position	16
4.5.3	The ESCC Component Number	16
4.5.4	Characteristics	16
4.5.4.1	Shell Size and Contact Arrangement	17
4.5.4.2	Type of Contact	17
4.5.4.3	Magnetism Level	17
4.5.4.4	Contact Information	17
4.5.5	Traceability Information	17
4.6	Electrical Measurements	17
4.6.1	Electrical Measurements at Room Temperature	17
4.6.2	Electrical Measurements at High and Low Temperatures (Table 3)	18
4.6.3	Circuits for Electrical Measurements (Figure 4)	18
4.7	Burn-in and Electrical Measurements (Tables 4 and 5)	18

4.8	Environmental and Endurance Tests (Charts IV and V of ESCC Generic Specification No. 3401)	18
4.8.1	Measurements and Inspections on Completion of Environmental Tests	18
4.8.2	Measurements and Inspections at Intermediate Points During Endurance Tests	18
4.8.3	Measurements and Inspections on Completion of Endurance Tests	18
4.8.4	Conditions for Operating Life Test (Part of Endurance Testing) (Table 5)	18
4.8.5	Electrical Circuit for Operating Life Test (Figure 5)	18
4.8.6	Conditions for High Temperature Storage Test (Part of Endurance Testing)	18

## 1. **GENERAL**

### 1.1 **SCOPE**

This specification details the ratings, physical and electrical characteristics, test and inspection data for Connectors, Electrical, Rectangular, Microminiature, Removable Gauge 26 Crimp Contacts, based on Type 8MCG. It shall be read in conjunction with:

- ESCC Generic Specification No. 3401, Connectors, Electrical, Non-Filtered, Circular and Rectangular.
- ESCC Detail Specification No. 3401/083, Contacts, Electrical, Crimp, Gauge 26, for 3401/082 Connectors.
- ESCC Detail Specification No. 3401/084, Accessories for Rectangular Connectors, Microminiature, 3401/081 and 3401/082.

the requirements of which are supplemented herein.

### 1.2 **COMPONENT TYPE VARIANTS AND RANGE OF COMPONENTS**

The different sizes of the connectors specified herein, together with their mechanical characteristics, are scheduled in Table 1(a).

### 1.3 **MAXIMUM RATINGS**

The maximum ratings, which shall not be exceeded at any time during use or storage, applicable to the connectors specified herein, are scheduled in Table 1(b).

### 1.4 **PARAMETER DERATING INFORMATION**

The derating information applicable to the connectors specified herein is shown in Figure 1.

### 1.5 **PHYSICAL DIMENSIONS**

The physical dimensions of the connectors specified herein, and the available contact arrangements, are shown in Figure 2.

## 2. **APPLICABLE DOCUMENTS**

The following documents form part of this specification and shall be read in conjunction with it:

- (a) ESCC Generic Specification No. 3401, Connectors, Electrical, Non-Filtered, Circular and Rectangular.
- (b) ESCC Detail Specification No. 3401/083, Contacts, Electrical, Crimp, Gauge 26, for 3401/082 Connectors.
- (c) ESCC Detail Specification No. 3401/084, Accessories for Rectangular Connectors, Microminiature, 3401/081 and 3401/082.

## 3. **TERMS, DEFINITIONS, ABBREVIATIONS, SYMBOLS AND UNITS**

For the purpose of this specification, the terms, definitions, abbreviations, symbols and units specified in ESCC Basic Specification No. 21300 shall apply.

**TABLE 1(a) - COMPONENT TYPE VARIANTS AND RANGE OF COMPONENTS SHELL SIZES**

Shell Size (Note 1)	Weight Max (g) (Note 2)				Mating Force (N) Max	Unmating Force (N)	
	Variant 01 (Note 3)		Variant 02 (Note 3)			Min	Max
	Male	Female	Male	Female			
A	1.05	1	1.35	1.45	11.9	0.95	11.9
B	1.35	1.25	1.75	1.8	18.7	1.5	18.7
C	1.6	1.45	2.15	2.2	22.1	1.8	22.1
D	1.8	1.65	2.35	2.4	28.9	2.35	28.9
E	2.1	1.88	2.7	2.69	35.7	2.9	35.7
F	2.35	2.1	2.95	2.9	42.5	3.5	42.5
G	2.5	2.2	3.15	3.05	56.1	4.6	56.1
H	3.44	2.95	4.2	4.1	86.7	7.1	86.7
J	6.1	4.75	7.3	6.45	178.8	14.5	178.8

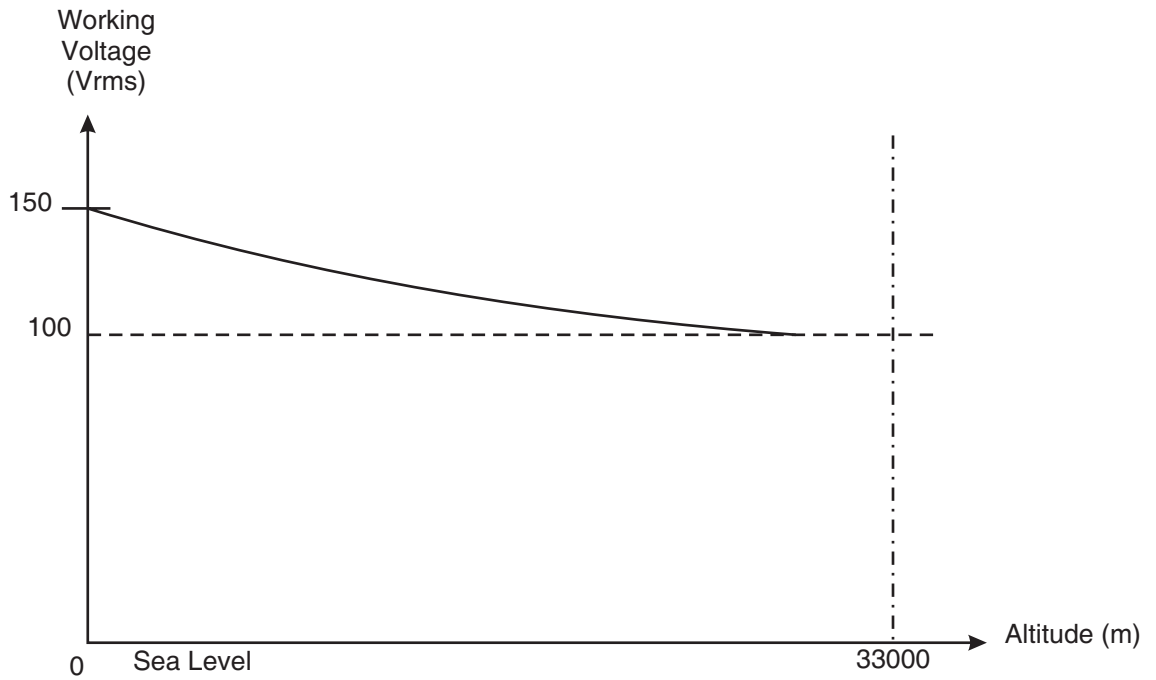
**NOTES:**

1. See Figure 2(a).
2. Without contacts but see Para. 4.5.4.4. See ESCC Detail Specification No. 3401/083 for contact weights.
3. Refer to Para. 4.4.1 for definition of the Type Variants.

**TABLE 1(b) - MAXIMUM RATINGS**

No.	Characteristics	Symbols	Maximum Ratings		Units
			Min	Max	
1	Working Voltage Sea Level	$U_R$	-	150	Vrms
2	Operating Temperature Range	$T_{op}$	-55	+125	°C
3	Storage Temperature Range	$T_{stg}$	-65	+125	°C

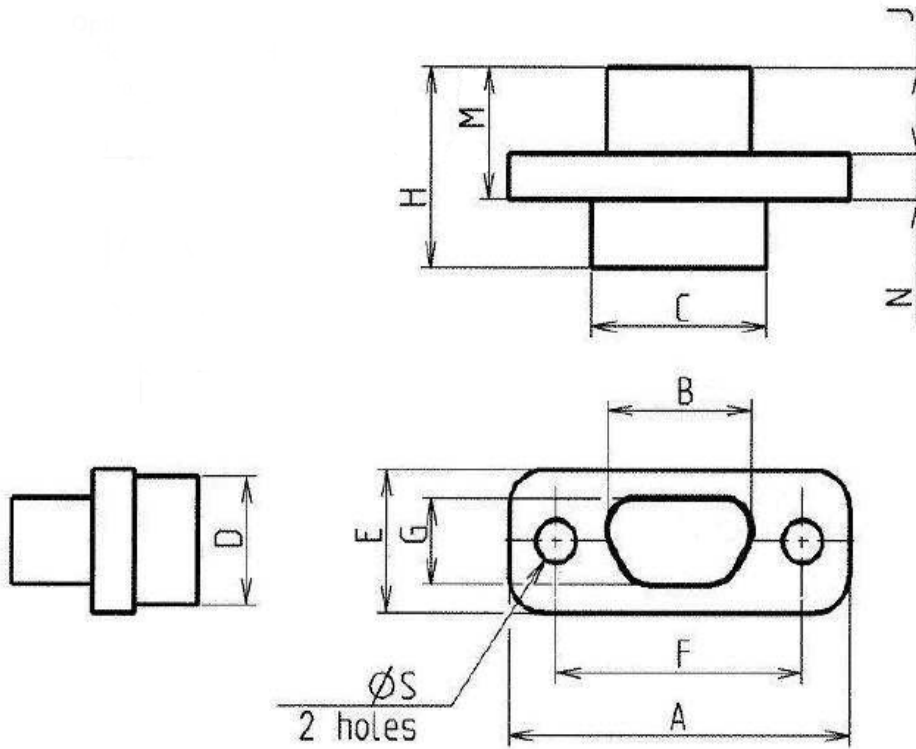
**FIGURE 1 - PARAMETER DERATING INFORMATION**



Working Voltage versus Altitude

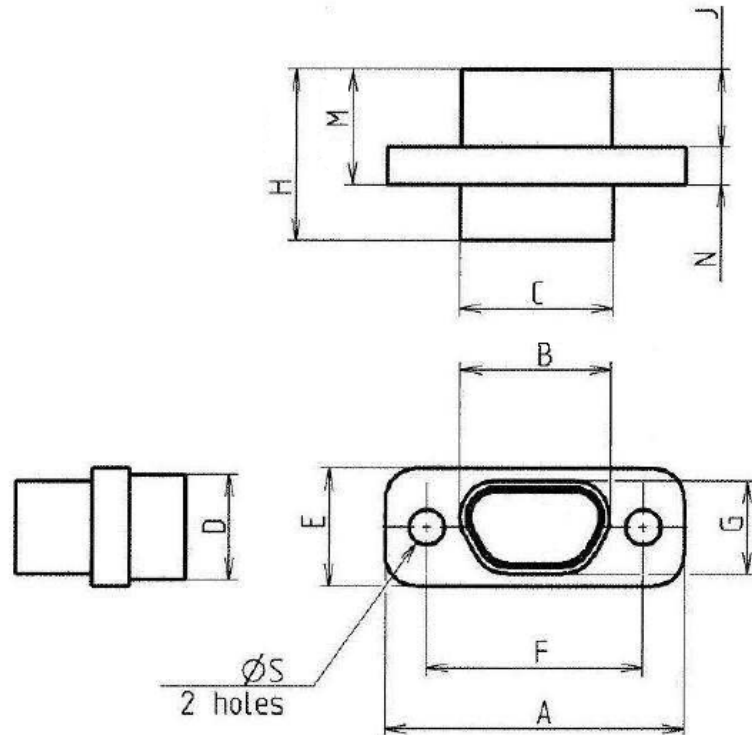


**FIGURE 2 - PHYSICAL DIMENSIONS**  
**FIGURE 2(a) - CONNECTOR SHELLS**  
**PLUG MALE CONTACTS**



Shell Size	A Max	B Max	C Max	D Max	E Max	F		G Max	H Max	J Max	M Max	N		ØS (Note 2)	
						Min	Max					Min	Max	Min	Max
A	19.94	8.48	10.16	6.86	7.82	14.22	14.48	4.69	10.82	4.72	7.21	2.23	2.49	2.23	2.39
B	23.75	12.29	13.97	6.86	7.82	18.03	18.29	4.69	10.82	4.72	7.21	2.23	2.49	2.23	2.39
C	27.56	16.1	17.78	6.86	7.82	21.84	22.1	4.69	10.82	4.72	7.21	2.23	2.49	2.23	2.39
D	30.1	18.64	20.32	6.86	7.82	24.38	24.64	4.69	10.82	4.72	7.21	2.23	2.49	2.23	2.39
E	33.91	22.45	24.13	6.86	7.82	28.19	28.45	4.69	10.82	4.72	7.21	2.23	2.49	2.23	2.39
F	37.72	26.26	27.94	6.86	7.82	32	32.26	4.69	10.82	4.72	7.21	2.23	2.49	2.23	2.39
G	36.45	24.99	26.67	7.87	8.92	30.73	30.99	5.78	10.82	4.72	7.21	2.23	2.49	2.23	2.39
H	48.55	36.85	38.65	7.87	8.92	43.23	43.49	5.78	10.82	4.72	7.21	2.23	2.49	2.23	2.39
J	62.75	45.1	47.65	11.25	12.5	54.72	54.98	9.25	10.82	4.72	7.21	2.23	2.49	3.68	3.83

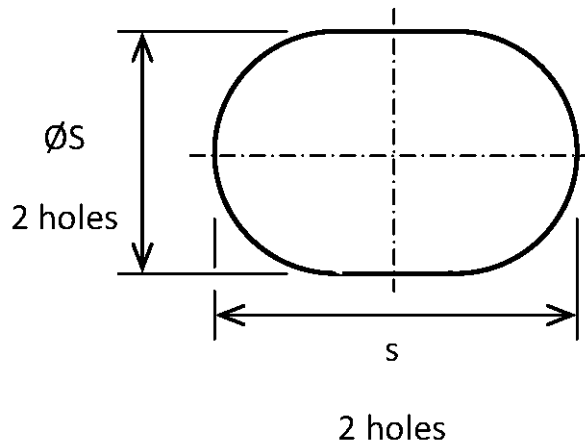
**RECEPTACLE FEMALE CONTACTS**



Shell Size	A Max	B Max	C Max	D Max	E Max	E		G Max	H Max	J Max	M Max	N		ØS (Note 2)	
						Min	Max					Min	Max	Min	Max
A	19.94	10.16	10.16	6.86	7.82	14.22	14.48	6.38	10.82	4.72	7.21	2.23	2.49	2.23	2.39
B	23.75	13.97	13.97	6.86	7.82	18.03	18.29	6.38	10.82	4.72	7.21	2.23	2.49	2.23	2.39
C	27.56	17.78	17.78	6.86	7.82	21.84	22.1	6.38	10.82	4.72	7.21	2.23	2.49	2.23	2.39
D	30.1	20.32	20.32	6.86	7.82	24.38	24.64	6.38	10.82	4.72	7.21	2.23	2.49	2.23	2.39
E	33.91	24.13	24.13	6.86	7.82	28.19	28.45	6.38	10.82	4.72	7.21	2.23	2.49	2.23	2.39
F	37.72	27.94	27.94	6.86	7.82	32	32.26	6.38	10.82	4.72	7.21	2.23	2.49	2.23	2.39
G	36.45	26.67	26.67	7.87	8.92	30.73	30.99	7.47	10.82	4.72	7.21	2.23	2.49	2.23	2.39
H	48.55	38.65	38.65	7.87	8.92	43.23	43.49	7.47	10.82	4.72	7.21	2.23	2.49	2.23	2.39
J	62.75	46.8	47.65	11.25	12.5	54.72	54.98	10.94	10.82	4.72	7.21	2.23	2.49	3.68	3.83

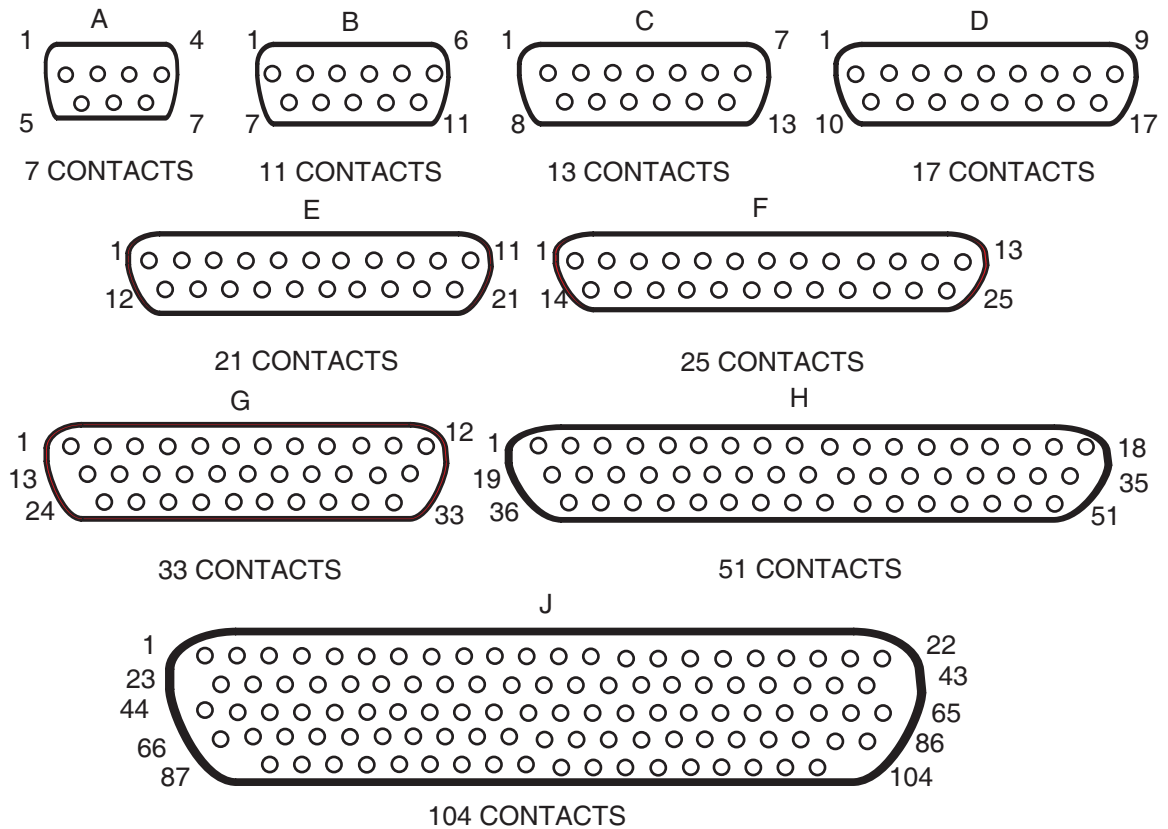
**NOTES:**

1. All dimensions are in millimetres.
2. For shell size H only, the mounting holes may be as shown below. Such holes shall be centred as per the circular holes shown above.



- Dimension s shall be 2.76mm minimum and 2.99mm maximum.
3. Only the underlined dimensions shall be checked during procurement.

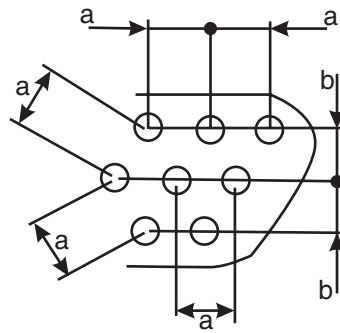
**FIGURE 2(b) - CONTACT ARRANGEMENTS**  
**FRONT VIEW MALE INSERT-USE MIRROR VIEW FOR FEMALE INSERT**



**NOTES:**

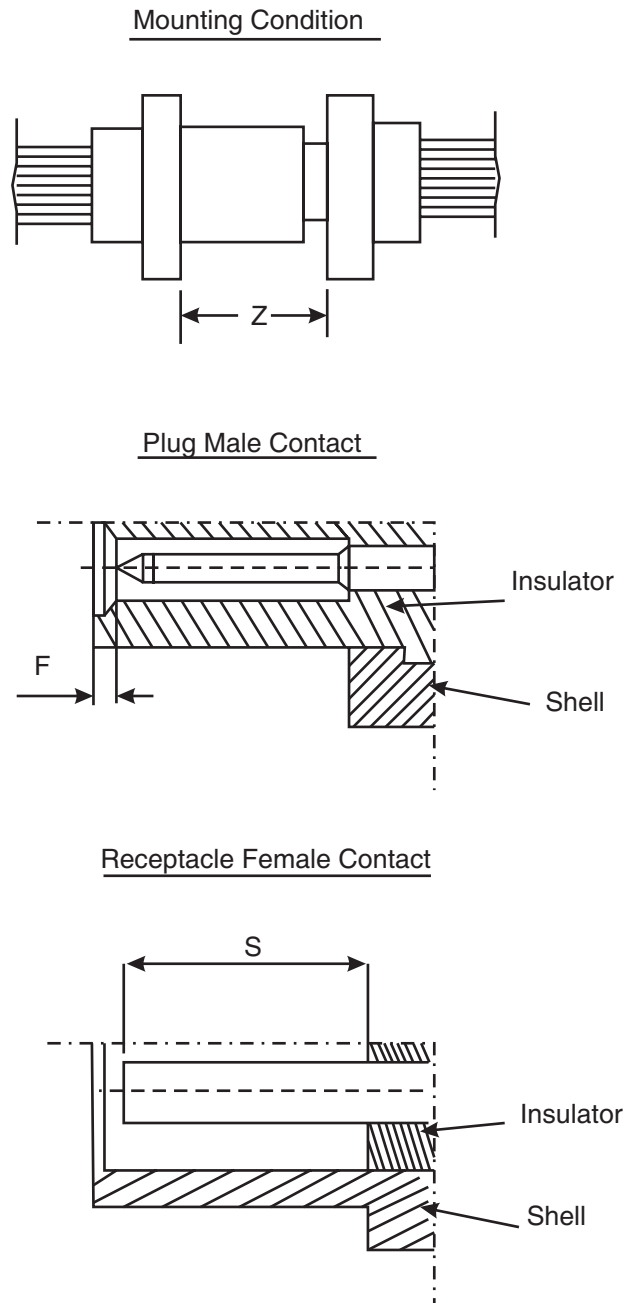
1. Only the outside contact cavities on each row are identified in the drawing, the remainder follow sequentially. Contact numbers are shown outside the insert for readability.

2.



a = Distance between contact centres: 2mm typical.  
b = Distance between rows: 1.732mm typical.

**FIGURE 2(c) - MATING DIMENSIONS AND CONTACT POSITION**



F		S		Z
Min	Max	Min	Max	Max
0.22	0.72	4.15	4.65	5.21

**NOTES:**

1. All dimensions are in millimetres.

#### 4. REQUIREMENTS

##### 4.1 GENERAL

The complete requirements for procurement of the components specified herein are stated in this specification and ESCC Generic Specification No. 3401. Deviations from the Generic Specification, applicable to this specification only, are detailed in Para. 4.2.

Deviations from the Generic Specification and this Detail Specification, formally agreed with specific Manufacturers on the basis that the alternative requirements are equivalent to the ESCC requirements and do not affect the components' reliability, are listed in the appendices attached to this specification.

##### 4.2 DEVIATIONS FROM GENERIC SPECIFICATION

###### 4.2.1 Deviations from Special In-Process Controls

None.

###### 4.2.2 Deviations from Final Production Tests (Chart II)

- (a) Para. 9.1.1.4, Mated Shell Conductivity: Not applicable.
- (b) Para. 9.9, Seal Test: Not applicable.

###### 4.2.3 Deviations from Burn-in and Electrical Measurements (Chart III)

Chart III is not applicable.

###### 4.2.4 Deviations from Qualification Tests (Chart IV)

- (a) Para. 9.1.1.4, Mated Shell Conductivity: Not applicable.
- (b) Para. 9.9, Seal Test: Not applicable.
- (c) Para. 9.24, Jackscrew Retention: Not applicable.
- (d) Para. 9.31, Solderability: Not applicable.

###### 4.2.5 Deviations from Lot Acceptance Tests (Chart V)

- (a) Para. 9.1.1.4, Mated Shell Conductivity: Not applicable.
- (b) Para. 9.9, Seal Test: Not applicable.
- (c) Para. 9.24, Jackscrew Retention: Not applicable.
- (d) Para. 9.31, Solderability: Not applicable.

##### 4.3 MECHANICAL REQUIREMENTS

###### 4.3.1 Dimension Check

The dimensions of the connectors specified herein shall be verified in accordance with requirements set out in Para. 9.6 of ESCC Generic Specification No. 3401 and shall conform to those shown in Figure 2 of this specification.

###### 4.3.2 Weight

The maximum weight of the connectors specified herein, without contacts, shall be as specified in Table 1(a).

- 4.3.3 Contact Capability  
As specified in ESCC Detail Specification No. 3401/083.
- 4.3.4 Contact Retention (in Insert)  
As specified in ESCC Detail Specification No. 3401/083.
- 4.3.5 Mating and Unmating Forces  
The forces applied for the mating and unmating of the connectors shall conform to the values specified in Table 1(a).
- 4.3.6 Insert Retention (in Shell)  
Connector inserts shall withstand a pressure of  $34.4\text{N/cm}^2$  without being dislodged from the shell.
- 4.3.7 Jackscrew Retention  
Not applicable.
- 4.3.8 Contact Insertion and Withdrawal Forces  
As specified in ESCC Detail Specification No. 3401/083.
- 4.3.9 Engagement and Separation Forces  
As specified in ESCC Detail Specification No. 3401/083.
- 4.3.10 Oversize Pin Exclusion  
As specified in ESCC Detail Specification No. 3401/083.
- 4.3.11 Probe Damage  
As specified in ESCC Detail Specification No. 3401/083.
- 4.3.12 Solderability  
Not applicable.
- 4.4 MATERIALS AND FINISHES  
The materials and finishes shall be as specified herein. Where a definite material is not specified, a material which will enable the connectors specified herein to meet the performance requirements of this specification shall be used. Acceptance or approval of any constituent material does not guarantee acceptance of the finished product.
- 4.4.1 Shells  
Variant 01  
  
Shells shall be made of glass-fibre reinforced thermoplastic. The plating shall be a minimum thickness of  $1.27\mu\text{m}$  gold over  $5\mu\text{m}$  minimum of electroless nickel or copper.  
  
Variant 02  
  
Shells shall be made of aluminium alloy. The plating shall be a minimum thickness of  $1.27\mu\text{m}$  gold over  $20\mu\text{m}$  minimum of electroless nickel.

#### 4.4.2 Inserts

Inserts shall be made of thermoplastic material.

#### 4.4.3 Contacts

As specified in ESCC Detail Specification No. 3401/083.

#### 4.4.4 Accessories

As specified in ESCC Detail Specification No. 3401/084.

#### 4.4.5 Magnetism Level

The allowable value of magnetism shall not exceed that specified for the relevant level (see Para. 4.5.4.3). Only magnetism levels NMC and NMD are verified.

### 4.5 MARKING

#### 4.5.1 General

The marking of all components delivered to this specification shall be in accordance with the requirements of ESCC Basic Specification No. 21700 and the following paragraphs. Each component shall be marked in respect of:

- (a) Contact Position.
- (b) The ESCC Component Number.
- (c) Characteristics.
- (d) Traceability Information.

#### 4.5.2 Contact Position

The contact positions shall be marked on the insert in accordance with Figure 2(b).

#### 4.5.3 The ESCC Component Number

Each component shall bear the ESCC Component Number which shall be constituted and marked as follows:

340108201B

- Detail Specification Number: 3401082
- Type Variant (see Table 1(a)): 01
- Testing Level: B

#### 4.5.4 Characteristics

The characteristics to be marked in the following order of precedence are:-

- (a) Shell Size.
- (b) Contact Arrangement.
- (c) Type of Contact.
- (d) Magnetism Level (only applicable to Variant 01).
- (e) Contact Information.

The information shall be constituted and marked as follows:-



Example: B11S-NMB-FO

- Shell Size: B
- Contact Arrangement: 11
- Type of Contact: S
- Magnetism Level (200 gamma): NMB
- Contact Information: FO

4.5.4.1 *Shell Size and Contact Arrangement*

Shell size shall be as designated in Table 1(a) and Figure 2(a). The shell size code also defines the contact arrangement. The layouts of the available contact arrangements are shown in Figure 2(b).

4.5.4.2 *Type of Contact*

Contact types shall be indicated by the following code letters.

Code Letter	Contact Type
P	Male
S	Female

4.5.4.3 *Magnetism Level*

The following codes shall be used for magnetism level. Magnetism level is not applicable to Variant 02 and therefore the magnetism level code shall be omitted.

Code	Definition
NMB	Magnetism Level: ≤200 gamma
NMC	Magnetism Level: ≤20 gamma
NMD	Magnetism Level: ≤2 gamma

4.5.4.4 *Contact Information*

-FO = Connector ordered without contacts. This information shall not be marked on the connector; it is only included on the packaging and all relevant data documentation.

Contacts must be from the same Manufacturer as the connector in which they are fitted and this shall be verified prior to assembly.

4.5.5 Traceability Information

Traceability information shall be marked in accordance with the requirements of ESCC Basic Specification No. 21700.

4.6 ELECTRICAL MEASUREMENTS

4.6.1 Electrical Measurements at Room Temperature

The parameters to be measured at room temperature are scheduled in Table 2. Unless otherwise

specified, measurements shall be performed at  $T_{amb}=+22\pm3^{\circ}C$ .

4.6.2 Electrical Measurements at High and Low Temperatures (Table 3)

Not applicable.

4.6.3 Circuits for Electrical Measurements (Figure 4)

Not applicable.

4.7 BURN-IN AND ELECTRICAL MEASUREMENTS (TABLES 4 AND 5)

Not applicable.

**TABLE 2 - ELECTRICAL MEASUREMENTS AT ROOM TEMPERATURE**

No.	Characteristic	Symbol	ESCC 3401 Test Method	Test Condition	Limits		Unit
					Min	Max	
1	Insulation Resistance	$R_i$	Para. 9.1.1.1	Para. 9.1.1.1	5000	-	$M\Omega$
2	Voltage Proof Leakage Current	$I_L$	Para. 9.1.1.2	600Vrms	-	2	mA

4.8 ENVIRONMENTAL AND ENDURANCE TESTS (CHARTS IV AND V OF ESCC GENERIC SPECIFICATION NO. 3401)

4.8.1 Measurements and Inspections on Completion of Environmental Tests

The parameters to be measured and inspections to be performed on completion of environmental testing are scheduled in Table 6. Unless otherwise specified, the measurements shall be performed at  $T_{amb}=+22\pm3^{\circ}C$ .

4.8.2 Measurements and Inspections at Intermediate Points During Endurance Tests

Not applicable.

4.8.3 Measurements and Inspections on Completion of Endurance Tests

The parameters to be measured and inspections to be performed on completion of endurance testing are scheduled in Table 6. Unless otherwise specified, the measurements shall be performed at  $T_{amb}=+22\pm3^{\circ}C$ .

4.8.4 Conditions for Operating Life Test (Part of Endurance Testing) (Table 5)

Not applicable.

4.8.5 Electrical Circuit for Operating Life Test (Figure 5)

Not applicable.

4.8.6 Conditions for High Temperature Storage Test (Part of Endurance Testing)

The requirements for the high temperature storage test are specified in Section 9 of ESCC Generic Specification No. 3401. The conditions for high temperature storage testing shall be the maximum storage temperature specified in Table 1(b) of this specification.

**Table 6 - MEASUREMENTS AND INSPECTIONS ON COMPLETION OF ENVIRONMENTAL AND ENDURANCE TESTING**

No.	ESCC Generic Spec. No. 3401		Measurements and Inspections		Symbol	Limits		Unit
	Environmental and Endurance Tests (Note 1)	Test Method and Conditions	Identification	Conditions		Min	Max	
01	Wiring	Para. 9.10	ESCC 3401/083	-	-	-	-	
02	Vibration	Para. 9.11	<b>Initial Measurements</b> Coupling screw(s) Unlocking Torque	-	Tq	Record Values		Nm
			<b>Final Measurements</b> Full Engagement					
			Coupling screw(s) Unlocking Torque Drift	-	$\Delta Tq/Tq$	-25	+25	%
			Visual Examination	-	-	-	-	-
03	Shock or Bump	Para. 9.12	Full Engagement Visual Examination	-	-	-	-	
04	Climatic Sequence	Para. 9.13	<b>Dry Heat</b> Insulation Resistance	Table 2, Item 1	R <sub>i</sub>	10	-	MΩ
			<b>Low Air Pressure</b> Voltage Proof Leakage Current	Figure 1	I <sub>L</sub>	Table 2, Item 2		mA
			<b>Damp Heat</b> Insulation Resistance	Immediately after test Table 2, Item 1	R <sub>i</sub>	1	-	MΩ
			<b>Final Measurements</b> External Visual Inspection	After 1-24hrs Recovery ESCC 3401 Para. 9.7	-	ESCC 3401 Para. 9.7		
			Insulation Resistance	Table 2, Item 1	R <sub>i</sub>	Table 2, Item 1		MΩ
			Voltage Proof Leakage Current	Table 2, Item 2	I <sub>L</sub>	Table 2, Item 2		mA
05	Plating Thickness	Para. 9.14	Thickness	-	-	Para. 4.4.1 of this spec.		
06	Rapid Change of Temperature	Para. 9.16	Visual Examination	-	-	-	-	
			Insulation Resistance	Table 2, Item 1	R <sub>i</sub>	Table 2, Item 1		MΩ
			Voltage Proof Leakage Current	Table 2, Item 2	I <sub>L</sub>	Table 2, Item 2		mA
07	Contact Retention (in Insert)	Para. 9.17 & Para. 4.3.4 of this spec.	Contact Displacement	-	-	ESCC 3401 Para. 9.17		
08	Endurance	Para. 9.18.	<b>Initial Measurements</b> Mating/Unmating Forces	-	F	Para. 4.3.5 of this spec.		N
			Low Level Contact Resistance	ESCC 3401/083	R <sub>cd</sub>	ESCC 3401/083 Record Values		mΩ
			<b>Final Measurements</b> Visual Examination	-	-	-	-	
			Mating/Unmating Forces	-	F	Para. 4.3.5 of this spec.		N

No.	ESCC Generic Spec. No. 3401		Measurements and Inspections		Symbol	Limits		Unit	
	Environmental and Endurance Tests (Note 1)	Test Method and Conditions	Identification	Conditions		Min	Max		
			Low Level Contact Resistance Drift	ESCC 3401/083	$\Delta R_{cl}$	ESCC 3401/083		m $\Omega$	
			Insulation Resistance	Table 2, Item 1	$R_i$	Table 2, Item 1		M $\Omega$	
			Voltage Proof Leakage Current	Table 2, Item 2	$I_L$	Table 2, Item 2		mA	
09	Permanence of Marking	Para. 9.19	As applicable	-	-	-	-		
10	Mating/Unmating Forces	Para. 9.20	Force	-	F	Para. 4.5.3 of this spec.		N	
11	High Temperature Storage	Para. 9.21	<b>Initial Measurements</b>						
			Low Level Contact Resistance	ESCC 3401/083	$R_{cl}$	ESCC 3401/083 Record Values		m $\Omega$	
			<b>Final Measurements</b>						
			Visual Examination	-	-	-	-		
			Mating/Unmating Forces	-	F	Para. 4.3.5 of this spec.		N	
			Low Level Contact Resistance Drift	ESCC 3401/083	$\Delta R_{cl}$	ESCC 3401/083		m $\Omega$	
			Rated Current Contact Resistance	ESCC 3401/083	$R_{cr}$	ESCC 3401/083		m $\Omega$	
			Insulation Resistance	Table 2, Item 1	$R_i$	Table 2, Item 1		M $\Omega$	
Voltage Proof Leakage Current	Table 2, Item 2	$I_L$	Table 2, Item 2		mA				
			Contact Retention (in Insert)	Para. 4.3.4 of this spec	-	ESCC 3401 Para. 9.17		N	
12	Corrosion	Para. 9.22	Visual Examination	-	-	-	-		
13	Insert Retention (in Shell)	Para. 9.23 & Para. 4.3.6 of this spec.	Visual Examination	-	-	Para. 4.3.6 of this spec.			
14	High Temperature Measurements	Para. 9.25	Insulation Resistance	Table 2, Item 1 (Note 2)	$R_i$	10	-	M $\Omega$	
15	Overload Test	Para. 9.26	Internal Temperature	-	T	-	+100	$^{\circ}$ C	
			Rated Current Contact Resistance	ESCC 3401/083	$R_{cr}$	ESCC 3401/083		m $\Omega$	
			Insulation Resistance	Table 2, Item 1	$R_i$	Table 2, Item 1		M $\Omega$	
			Voltage Proof Leakage Current	Table 2, Item 2	$I_L$	Table 2, Item 2		mA	
16	Maintenance Aging	Para. 9.27	Visual Examination	-	-	-	-		
			Contact Retention	Para. 4.3.4 of this spec	-	ESCC 3401 Para. 9.17		N	
			Contact Insertion & Withdrawal Forces	Para. 4.3.4 of this spec	-	Para. 4.3.8 of this spec		N	
17	Engage/Separation Forces	Para. 9.28 and Para. 4.3.9 of this spec.	Force	-	F	Para. 4.3.9 of this spec		N	

No.	ESCC Generic Spec. No. 3401		Measurements and Inspections		Symbol	Limits		Unit
	Environmental and Endurance Tests (Note 1)	Test Method and Conditions	Identification	Conditions		Min	Max	
18	Oversize Pin Exclusion	Para. 9.29 and Para. 4.3.10 of this spec.	-	-	-	Para. 4.3.10 of this spec		
19	Probe Damage	Para. 9.30 and Para. 4.3.11 of this spec.	Contact Separation Force	-	F	Para. 4.3.11 of this spec		N

**NOTES:**

1. The tests in this table refer to either Chart IV or V and shall be used as applicable.
2.  $T_{amb}=+125^{\circ}C$ .