



Pages 1 to 25

**CONNECTORS, ELECTRICAL, TRIAXIAL, BAYONET
COUPLING, MIL-STD-1553B DATABUS WITH NON-
REMOVABLE CRIMP CONTACTS**

BASED ON TYPE ACB1 SERIES

ESCC Detail Specification No. 3401/079

Issue 2	February 2012
---------	---------------



Document Custodian: European Space Agency - see <https://escies.org>

LEGAL DISCLAIMER AND COPYRIGHT

European Space Agency, Copyright © 2012. All rights reserved.

The European Space Agency disclaims any liability or responsibility, to any person or entity, with respect to any loss or damage caused, or alleged to be caused, directly or indirectly by the use and application of this ESCC publication.

This publication, without the prior permission of the European Space Agency and provided that it is not used for a commercial purpose, may be:

- copied in whole, in any medium, without alteration or modification.
- copied in part, in any medium, provided that the ESCC document identification, comprising the ESCC symbol, document number and document issue, is removed.

DOCUMENTATION CHANGE NOTICE

(Refer to <https://escies.org> for ESCC DCR content)

DCR No.	CHANGE DESCRIPTION
690	Specification updated to incorporate editorial and technical changes per DCR.

TABLE OF CONTENTS

<u>1.</u>	<u>GENERAL</u>	<u>6</u>
1.1	Scope	6
1.2	Type Variants	6
1.3	Maximum Ratings	6
1.4	Parameter Derating Information	6
1.5	Physical Dimensions	6
<u>2.</u>	<u>APPLICABLE DOCUMENTS</u>	<u>16</u>
<u>3.</u>	<u>TERMS, DEFINITIONS, ABBREVIATIONS, SYMBOLS AND UNITS</u>	<u>16</u>
<u>4.</u>	<u>REQUIREMENTS</u>	<u>16</u>
4.1	General	16
4.2	Deviations from Generic Specification	16
4.2.1	Deviations from Special In-process Controls	16
4.2.2	Deviations from Final Production Tests (Chart IIb)	16
4.2.3	Deviations from Burn-in and Electrical Measurements (Chart III)	16
4.2.4	Deviations from Qualification Tests (Chart IV)	16
4.2.5	Deviations from Lot Acceptance Tests (Chart V)	17
4.3	Mechanical Requirements	17
4.3.1	Dimension Check	17
4.3.2	Weight	17
4.3.3	Contact Capability	17
4.3.4	Contact Retention (In Insert)	17
4.3.5	Mating and Unmating Forces	18
4.3.6	Insert Retention (In Shell)	18
4.3.7	Jackscrew Retention	18
4.3.8	Contact Insertion and Withdrawal Forces	18
4.3.9	Engagement and Separation Forces	18
4.3.10	Oversize Pin Exclusion	18
4.3.11	Probe Damage	19
4.3.12	Solderability	19
4.3.13	Joint Strength (Ferrule and Shell to AWG24 Cable Braid)	19
4.3.14	Joint Strength (Contacts to AWG24 Cable Inner Wires)	19
4.4	Materials and Finishes	19
4.4.1	Connector Shell	19
4.4.2	Ferrule	19
4.4.3	Contacts	19
4.4.4	Insulator	19
4.4.5	Cable for Variants 17 and 18	19
4.4.6	Heat Shrinkable Strain Relief Sleeve	20
4.4.7	Magnetism Level	20
4.5	Marking	20
4.5.1	General	20
4.5.2	The ESCC Component Number	20
4.5.3	Characteristics	20
4.5.4	Traceability Information	20
4.6	Electrical Measurements	20
4.6.1	Electrical Measurements at Room Temperature	20
4.6.2	Electrical Measurements at High and Low Temperatures	20
4.6.3	Circuits for Electrical Measurements	20
4.7	Burn-in and Electrical Measurements	21
4.8	Environmental and Endurance Tests	21



4.8.1	Measurements and Inspections on Completion of Environmental Tests	21
4.8.2	Measurements and Inspections at Intermediate Points During Endurance Tests	21
4.8.3	Measurements and Inspections on Completion of Endurance Tests	21
4.8.4	Conditions for Operating Life (Part of Endurance Testing)	21
4.8.5	Electrical Circuit for Operating Life	21
4.8.6	Conditions for High Temperature Storage Test (Part of Endurance Testing)	21

1. GENERAL

1.1 SCOPE

This specification details the ratings, physical and electrical characteristics, test and inspection data for Connectors, Electrical, Triaxial, Bayonet Coupling, MIL-STD-1553B Databus with Non-removable Crimp Contacts, based on type ACB1 Series.

The specification shall be read in conjunction with:

- ESCC Generic Specification No. 3401, Connectors, Electrical, Non-Filtered Circular and Rectangular.

the requirements of which are supplemented herein.

1.2 TYPE VARIANTS

Variants of the basic connector covered by this specification are given in Table 1(a).

1.3 MAXIMUM RATINGS

The maximum ratings, which shall not be exceeded at any time during use or storage, applicable to the connectors specified herein, are as scheduled in Table 1(b).

1.4 PARAMETER DERATING INFORMATION

Not applicable.

1.5 PHYSICAL DIMENSIONS

The physical dimensions of the connectors specified herein are shown in Figure 2.

TABLE 1(a) - TYPE VARIANTS

Variant	Component Type Note 3	Contact Type	Accepted AWG24 Cable Outer Diameter (mm) Note 1	Weight Max. (g)
01	Plug 3 Lugs, Straight	Pin	≤ 3.4	14
02	Plug 3 Lugs, Straight	Pin	>3.4, ≤ 3.8	14
03	Plug 3 Lugs, Right Angle	Pin	≤ 3.4	16.5
04	Plug 3 Lugs, Right Angle	Pin	>3.4, ≤ 3.8	16.5
05	Plug 4 Lugs, Straight	Pin	≤ 3.4	14
06	Plug 4 Lugs, Straight	Pin	>3.4, ≤ 3.8	14
07	Plug 4 Lugs, Right Angle	Pin	≤ 3.4	16.5
08	Plug 4 Lugs, Right Angle	Pin	>3.4, ≤ 3.8	16.5
09	Bulkhead Jack 3 Lugs, Straight	Socket	≤ 3.4	9

Variant	Component Type Note 3	Contact Type	Accepted AWG24 Cable Outer Diameter (mm) Note 1	Weight Max. (g)
10	Bulkhead Jack 3 Lugs, Straight	Socket	>3.4, ≤ 3.8	9
11	Bulkhead Jack 3 Lugs, Right Angle	Socket	≤ 3.4	11.5
12	Bulkhead Jack 3 Lugs, Right Angle	Socket	>3.4, ≤ 3.8	11.5
13	Bulkhead Jack 4 Lugs, Straight	Socket	≤ 3.4	9
14	Bulkhead Jack 4 Lugs, Straight	Socket	>3.4, ≤ 3.8	9
15	Bulkhead Jack 4 Lugs, Right Angle	Socket	≤ 3.4	11.5
16	Bulkhead Jack 4 Lugs, Right Angle	Socket	>3.4, ≤ 3.8	11.5
17	Bulkhead Jack 3 Lugs, Pigtail	Socket	Not applicable	12 Note 2
18	Bulkhead Jack 4 Lugs, Pigtail	Socket	Not applicable	12 Note 2

NOTES:

- All cables are 77Ω MIL-STD-1553B Data Bus twisted shielded pairs.
- Supplied with one nut and plain washer assembled with 30cm of AWG24 twisted pair cable per ESCC 3901/013 Variant 08 or equivalent. The colour of the wires are not user definable and they are not colour coded to denote connection.
- With the exception of Variants 17 and 18 all connectors are supplied in kits comprising:
 - one connector shell.
 - one insulator.
 - one contact (pin or socket).
 - one ferrule.
 - one heat shrinkable strain relief sleeve (Right Angle Variants only).
 - one nut and plain washer (Bulkhead Variants only).

TABLE 1(b) - MAXIMUM RATINGS

No.	Characteristics	Symbol	Maximum Rating	Unit	Notes
1	Working Voltage	U_R	200	Vrms	
2	Rated Current (contact)	I_{CR}	1	A	
3	Operating Temperature Range	T_{op}	-55 to +150	°C	T_{amb}
4	Storage Temperature Range	T_{stg}	-55 to +150	°C	
5	Mounting Nut Locking Torque Range	τ_m	1.9 to 2.1	Nm	Variants 09 through 18

FIGURE 2 - PHYSICAL DIMENSIONS

Consolidated Notes are at the end of Figure 2.

FIGURE 2(a) - Plug, Straight (Variants 01, 02, 05 and 06)

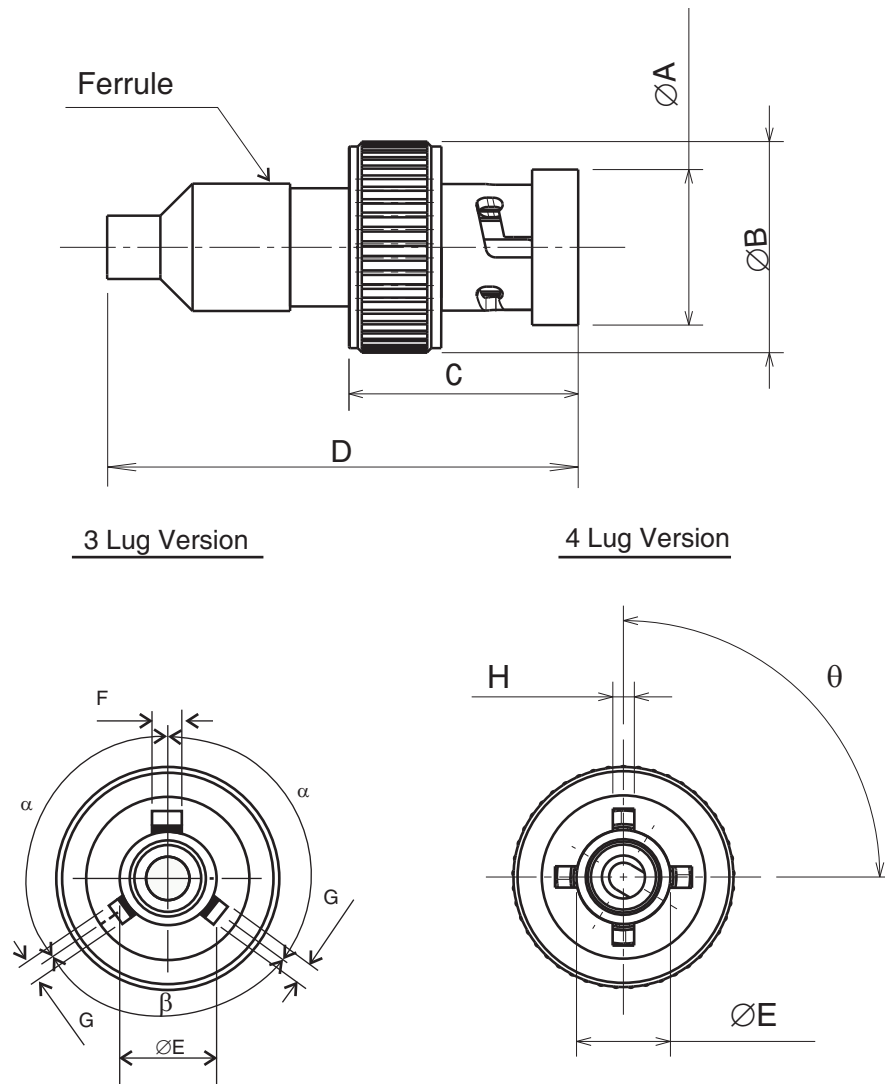

Symbols	Dimensions mm		Notes
	Min	Max	
ØA	-	10.9	
ØB	-	14.65	
C	-	16.6	
D	-	35	
ØE	6.2	6.3	
F	1.95	2.05	1
G	1.37	1.47	2
H	1.37	1.47	3
α	123°	127°	2
β	108°	112°	1

Symbols	Dimensions mm		Notes
	Min	Max	
θ	88°	92°	3

Figure 2(b) - Plug, Right Angle (Variants 03, 04, 07 and 08)

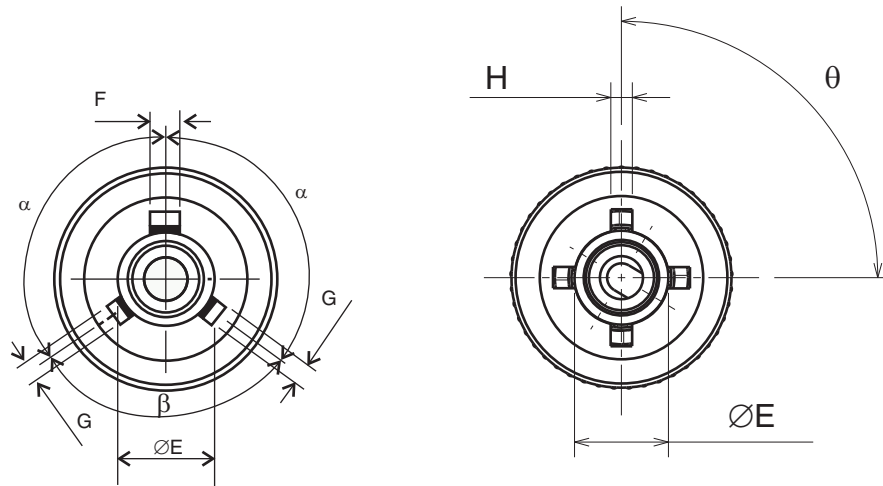
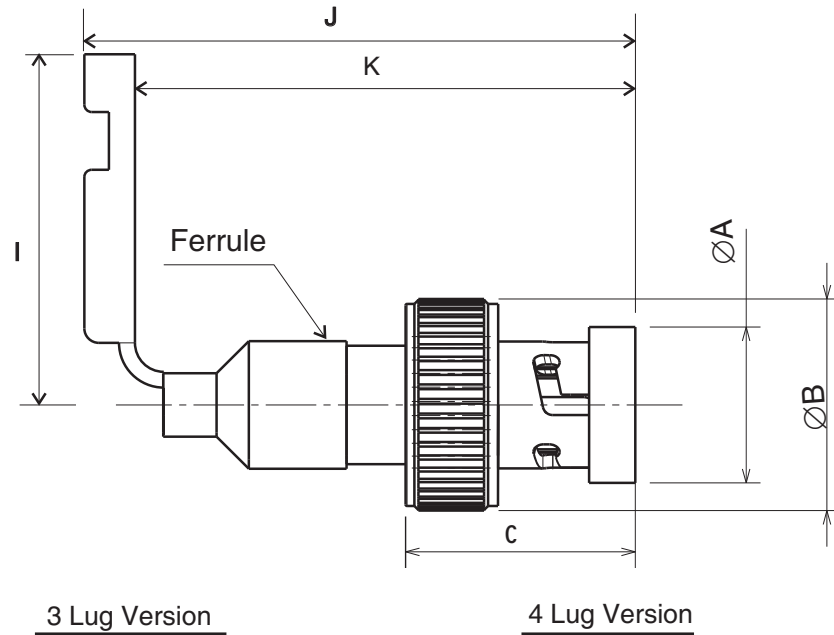

Symbols	Dimensions mm		Notes
	Min	Max	
$\text{Ø}A$	-	10.9	
$\text{Ø}B$	-	14.65	
C	-	16.6	
$\text{Ø}E$	6.2	6.3	
F	1.95	2.05	1

Symbols	Dimensions mm		Notes
	Min	Max	
G	1.37	1.47	2
H	1.37	1.47	3
I	-	28	
J	-	40	
K	32	-	
α	123°	127°	2
β	108°	112°	1
θ	88°	92°	3

Figure 2(c) - Bulkhead Jack, Straight (Variants 09, 10, 13 and 14)

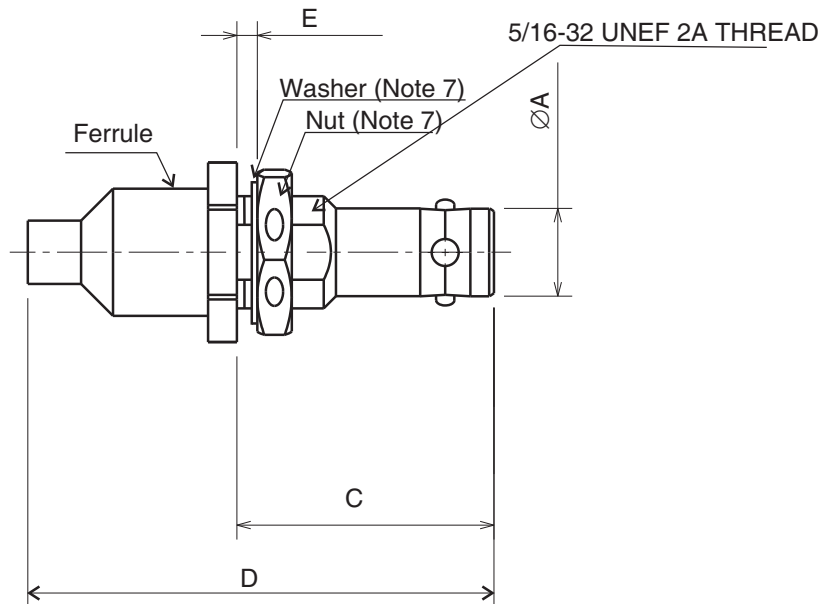

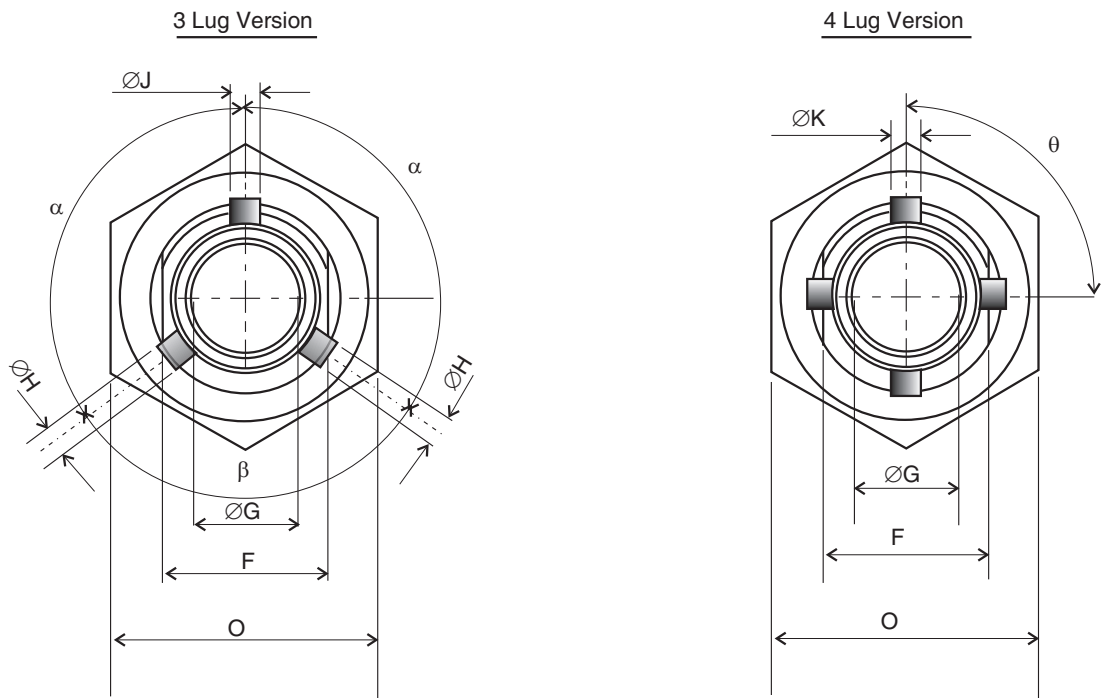

Symbols	Dimensions mm		Notes
	Min	Max	
ØA	6.08	6.12	
C	17.8	18	
D	-	35	
E	1	3.5	4
F	6.75	6.8	
ØG	2.85	2.9	
ØH	1.22	1.32	2
ØJ	1.83	1.93	1
ØK	1.22	1.32	3
O	10.9	11	
α	123°	127°	2
β	108°	112°	1
θ	88°	92°	3

Figure 2(d) - Bulkhead Jack, Right Angle (Variants 11, 12, 15 and 16)

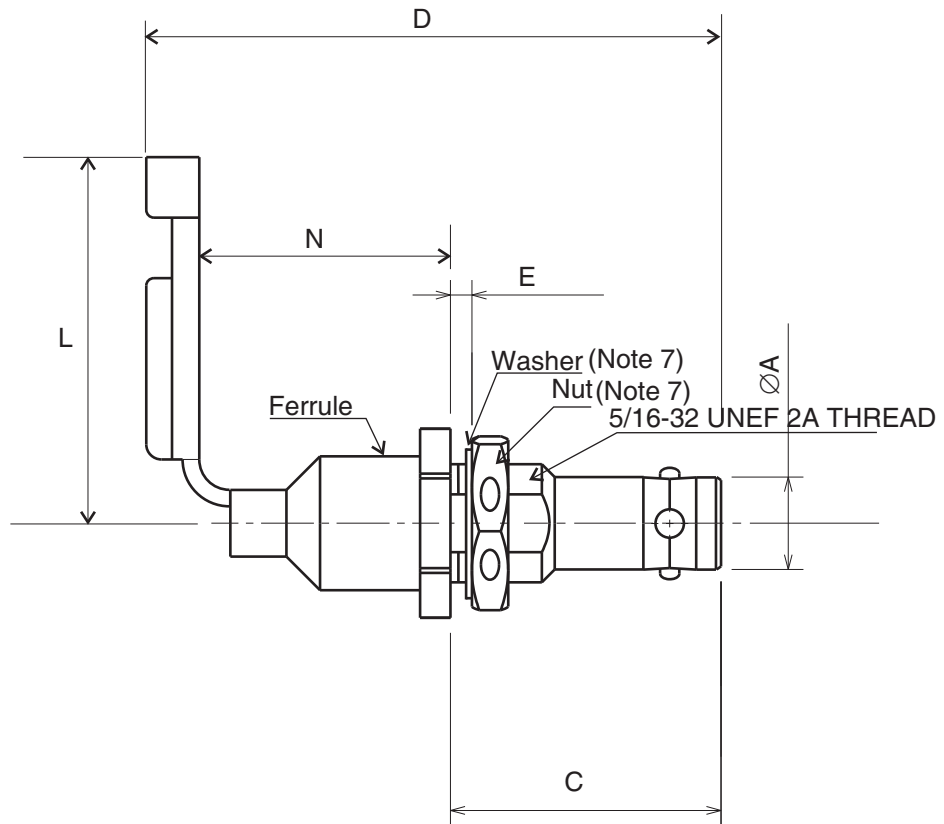

3 Lug Version

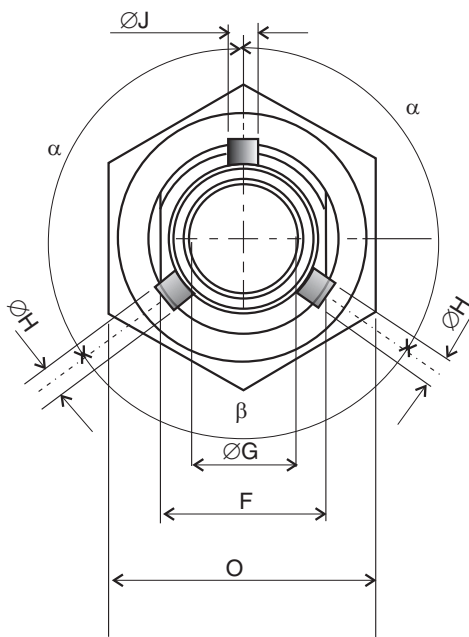

4 Lug Version

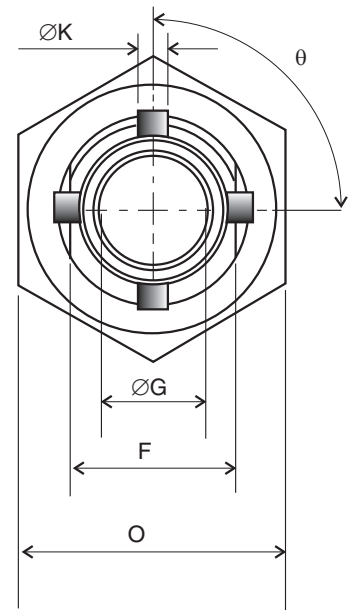

Symbols	Dimensions mm		Notes
	Min	Max	
ØA	6.08	6.12	
C	17.8	18	
D	-	40	
E	1	3.5	4
F	6.75	6.8	
ØG	2.85	2.9	
ØH	1.22	1.32	2
ØJ	1.83	1.93	1
ØK	1.22	1.32	3
L	-	28	
N	13.7	-	
O	10.9	11	
α	123°	127°	2
β	108°	112°	1
θ	88°	92°	3

Figure 2(e) - Bulkhead Jack, Pigtail (Variants 17 and 18)

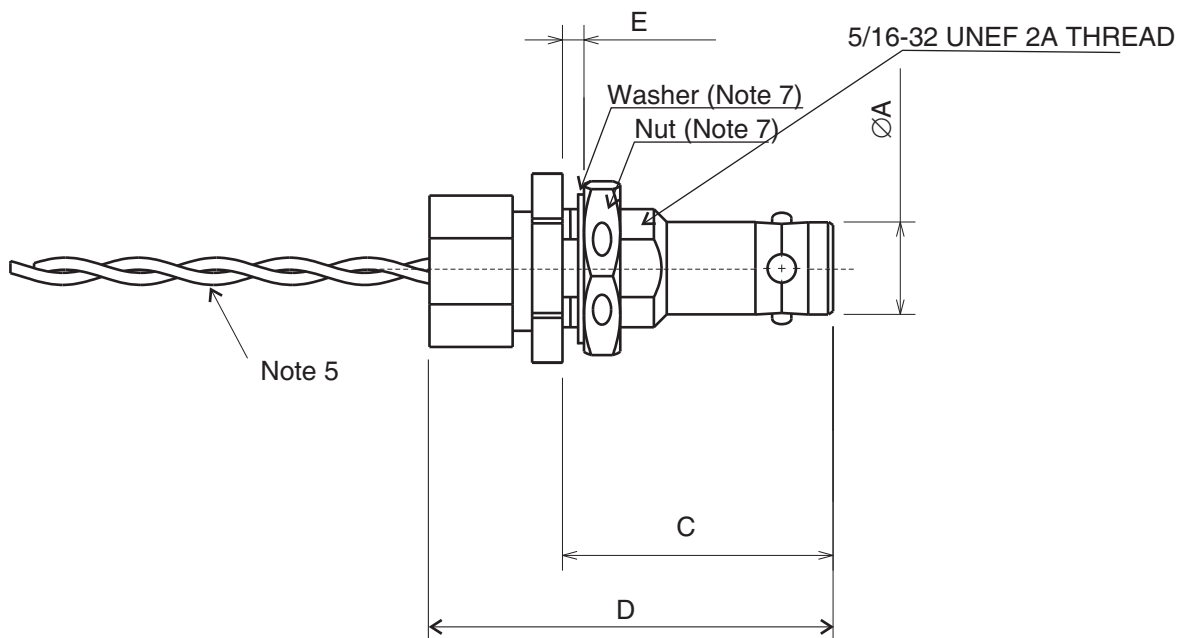

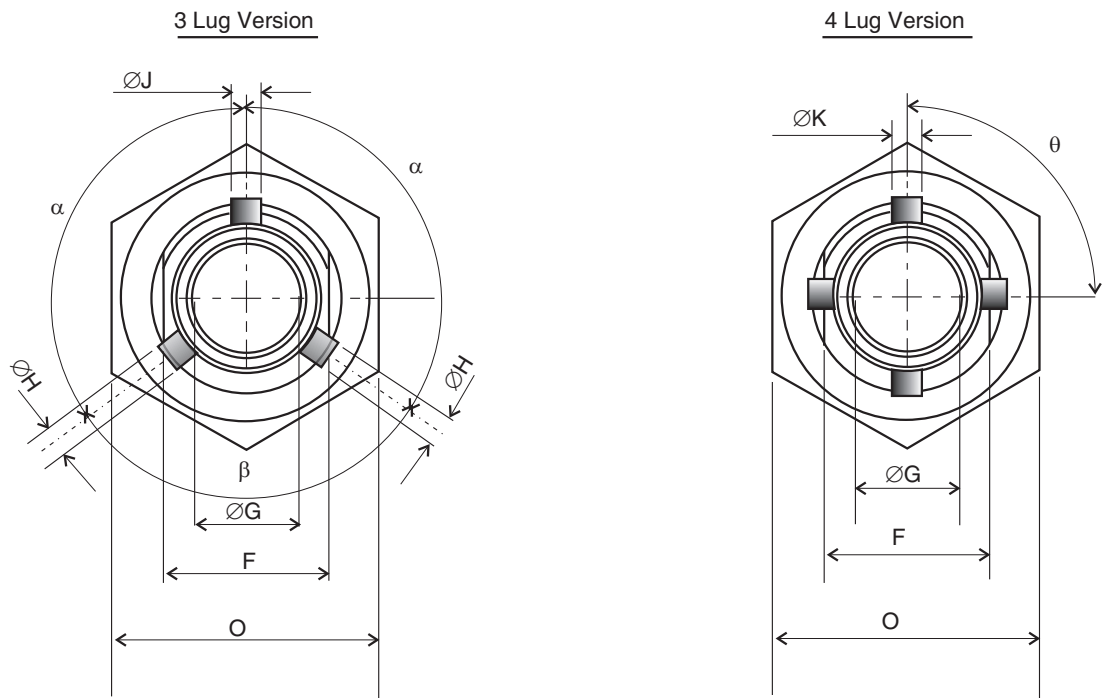

Symbols	Dimensions mm		Notes
	Min	Max	
ØA	6.08	6.12	
ØB	0.05	0.25	
C	17.8	18	
D	-	27	
E	1	3.5	4
F	6.75	6.8	
ØG	2.85	2.9	
ØH	1.22	1.32	2
ØJ	1.83	1.93	1
ØK	1.22	1.32	3
O	10.9	11	
α	123°	127°	2
β	108°	112°	1
θ	88°	92°	3

Figure 2(f) - Inner Contacts

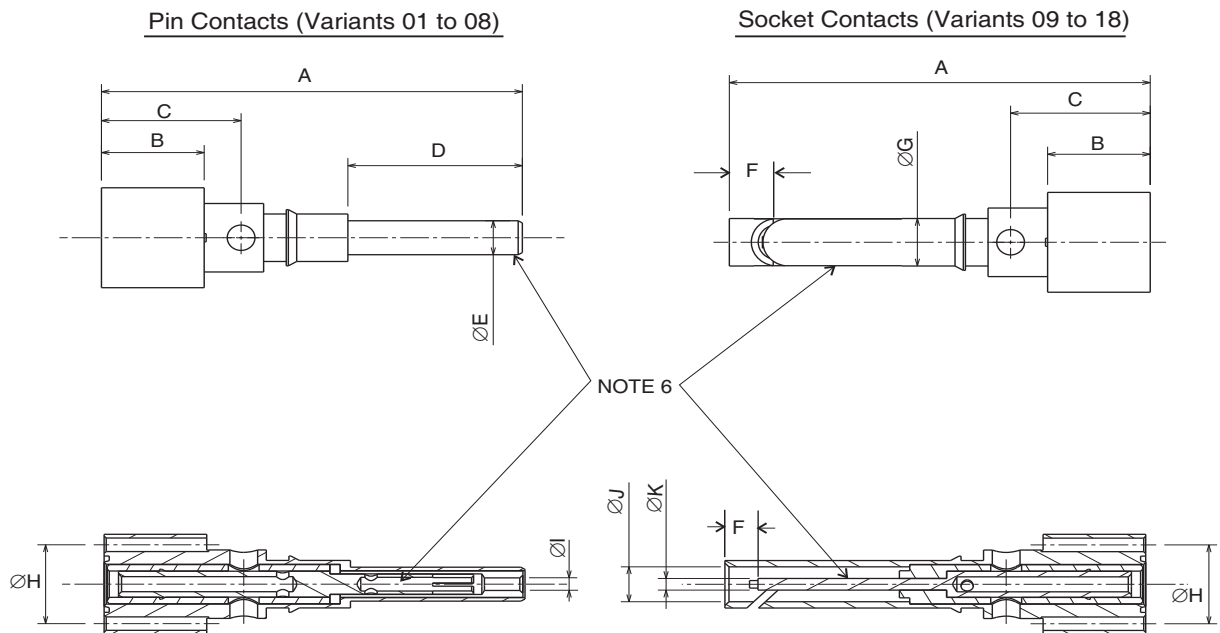

Symbols	Dimensions mm		Notes
	Min	Max	
A	20.45	20.55	
B	4.9	5.1	
C	6.67	6.93	
D	8.4	8.6	
ØE	1.8	1.82	
F	1.2	1.4	
ØG	2.5	2.6	
ØH	4.15	4.25	
ØI	0.64	0.7	
ØJ	1.89	1.91	
ØK	0.61	0.63	

Consolidated Notes for Figure 2

1. 1 place.
2. 2 places.
3. 4 places.
4. Range of acceptable panel thickness.
5. See Note 2 of Type Variants.
6. Measurement points for Gold Plating Thickness testing.
7. Nut and plain washer in accordance with 5/16-32 UNEF 2A. The nut shall have three holes of diameter 1.2 ± 0.1 mm for use with AWG24 locking wire.

2. **APPLICABLE DOCUMENTS**

The following documents form part of this specification and shall be read in conjunction with it:

- (a) ESCC Generic Specification No. 3401 for Connectors, Electrical, Non-Filtered, Circular and Rectangular.
- (b) MIL-STD-1553B, Aircraft Internal Time Division Command/Response Multiplex Data Bus.
- (c) ASTM-B-733, Metal, Autocatalytic Electroless Nickel-Phosphorus Coatings on.
- (d) MIL-G-45204, Gold plating, electro deposited.
- (e) ECSS-Q-ST-70-26, Crimping of high-reliability electrical connections.

3. **TERMS, DEFINITIONS, ABBREVIATIONS, SYMBOLS AND UNITS**

For the purpose of this specification, the terms, definitions, abbreviations, symbols and units specified in ESCC Basic Specification No. 21300 shall apply.

4. **REQUIREMENTS**

4.1 **GENERAL**

The complete requirements for procurement of the connectors specified herein are stated in this specification and ESCC Generic Specification No. 3401. Deviations from the Generic Specification, applicable to this specification only, are detailed in Para. 4.2.

Deviations from the applicable Generic Specification and this Detail Specification, formally agreed with specific Manufacturers on the basis that the alternative requirements are equivalent to the ESCC requirements and do not affect the components' reliability, are listed in the appendices attached to this specification.

4.2 **DEVIATIONS FROM GENERIC SPECIFICATION**

4.2.1 **Deviations from Special In-process Controls**

- (a) Para. 5.2.4, Crimping Capability: shall be performed on a sample of 5% of the production lot or a minimum of 3 samples, limited to 10 contacts. The requirements of ECSS-Q-ST-70-26 shall be applied. Voltage Drop shall be tested as specified in Table 2 herein.

4.2.2 **Deviations from Final Production Tests (Chart IIb)**

- (a) Para. 9.2, Mating Verification: shall be performed on the connector body without contacts.
- (b) Para. 9.5, Magnetism Level: Not applicable.
- (c) Para. 9.8, Installation of Contacts into Inserts: Not applicable.
- (d) Para. 9.1.4, Electrical Measurements at Room Temperature: shall be performed on 5% of the production lot or a minimum of 3 samples, which shall be assembled for test purposes.

4.2.3 **Deviations from Burn-in and Electrical Measurements (Chart III)**

Not applicable.

4.2.4 Deviations from Qualification Tests (Chart IV)

- (a) Para. 9.9, Seal Test: Not applicable.
- (b) Para. 9.10, Wiring: Voltage Drop shall be tested as specified in Table 2, and Rated Current Contact Resistance shall also be performed.
- (c) Para. 9.15, Joint Strength: Shall be performed as specified in Paragraphs 4.3.13 and 4.3.14 of this specification.
- (d) Para. 9.19, Permanence of Marking: Not applicable as connectors are unmarked.
- (e) Para. 9.21, Rated Current Contact Resistance: Shall also be performed
- (f) Para. 9.23, Insert Retention: Not applicable.
- (g) Para. 9.24, Jackscrew Retention: Not applicable.
- (h) Para. 9.26, Overload Test: Not applicable.
- (i) Para 9.27, Maintenance Aging: Not applicable.
- (j) Para 9.29, Oversize Pin Exclusion: Not applicable.
- (k) Para 9.30, Probe Damage: Not applicable.
- (l) Para 9.31, Solderability: Not applicable.

4.2.5 Deviations from Lot Acceptance Tests (Chart V)

- (a) Para. 9.9, Seal Test: Not applicable.
- (b) Para. 9.14, Plating Thickness: Not applicable.
- (c) Para. 9.15, Joint Strength: Shall be performed as specified in Paragraphs 4.3.13 and 4.3.14 of this specification.
- (d) Para. 9.19, Permanence of Marking: Not applicable
- (e) Para. 9.27, Maintenance Aging: Not applicable
- (f) Para. 9.29, Oversize Pin Exclusion: Not applicable.
- (g) Para. 9.30, Probe Damage: Not applicable.

4.3 MECHANICAL REQUIREMENTS

4.3.1 Dimension Check

The dimensions of the connectors specified herein shall be verified in accordance with the requirements set out in Para. 9.6 of ESCC Generic Specification No. 3401 and they shall conform to those shown in Figure 2 of this specification.

4.3.2 Weight

The maximum weight of the connectors specified herein shall be as specified in Table 1(a).

4.3.3 Contact Capability

The pick-up and drop weights shall be:

Variant	Test applicability	Test gauge		Pick-up Weight (g)	Drop Weight (g)
		Ø Min (mm)	Ø Max (mm)		
01 to 08	Central Contact	0.629	0.632	-	50
		0.584	0.587	5	-

Variant	Test applicability	Test gauge		Pick-up Weight (g)	Drop Weight (g)
		Ø Min (mm)	Ø Max (mm)		
09 to 18	Intermediate Contact	1.877	1.879	-	1400
		1.829	1.831	140	-

4.3.4 Contact Retention (In Insert)

The contact retention force of the intermediate and central contacts within the insert shall be:

Variant	Test applicability	Test Force (N)	Displacement (mm)
01 to 08	Intermediate contact	45	0.8 max.
09 to 18	Central contact	10	0.8 max.

4.3.5 Mating and Unmating Forces

These tests shall be performed by applying a constant axial force and measuring the coupling torque.

The forces applied for mating and unmating of the connectors shall be:

Mating		Unmating	
Applied Axial Force (N)	Maximum coupling torque τ_c (Nm)	Applied Axial Force (N)	Maximum coupling torque τ_c (Nm)
50	0.5	50	0.5

4.3.6 Insert Retention (In Shell)

Not applicable.

4.3.7 Jackscrew Retention

Not applicable.

4.3.8 Contact Insertion and Withdrawal Forces

Not applicable.

4.3.9 Engagement and Separation Forces

The engagement and separation forces shall be tested on the assembled samples during Final Production Tests on the socket inner contact and the pin intermediate contact, with the applicable test pin, and the following limits applied:

Contact type	Test gauge			Max engagement force (N)	Min separation force (N)
	Type	Ø Min (mm)	Ø Max (mm)		
Socket Inner contact	Max gauge	0.629	0.632	2.24	-
	Min gauge	0.584	0.587	-	0.11
Pin Intermediate contact	Max gauge	1.877	1.879	14	-
	Min gauge	1.829	1.831	-	0.41

4.3.10 Oversize Pin Exclusion

Not applicable.

4.3.11 Probe Damage

Not applicable.

4.3.12 Solderability

Not applicable.

4.3.13 Joint Strength (Ferrule and Shell to AWG24 Cable Braid)

The connector ferrule and shell shall be crimped to compatible AWG24 MIL-STD-1553B single or double braid data bus cables for test purposes. The contacts shall not be wired. The minimum tensile joint strength measured between the connector and cable braid shall be 100N. Both single braid and double braid twisted shielded pair cables shall be tested with the connector.

4.3.14 Joint Strength (Contacts to AWG24 Cable Inner Wires)

Two AWG24 stranded wires shall be crimped, one to the central contact and one to the intermediate contact. The joints shall be pulled with the following limits applied:

Variant	Contact type	Wire type	Tensile strength minimum value
01 to 08	Pin	AWG 24, high strength copper alloy	60 N
09 to 18	Socket	AWG 24, high strength copper alloy	60 N

4.4 MATERIALS AND FINISHES

The materials and finishes shall be as specified herein. Where a definite material is not specified, a material which will enable the connectors specified herein to meet the performance requirements of this specification shall be used. Acceptance or approval of any constituent material does not guarantee acceptance of the finished product.

4.4.1 Connector Shell

The connector shell shall be made of brass (53% copper, 40% zinc and 3% lead). The plating shall be 5±1µm of nickel per ASTM-B-733.

4.4.2 Ferrule

The ferrule shall be made of copper alloy (99% copper and 1% tellurium). The plating shall be $5\pm 1\mu\text{m}$ of nickel per ASTM-B-733.

4.4.3 Contacts

The contacts shall be made of copper alloy (98% copper and 2% beryllium) with $0.2\mu\text{m}$ of nickel underplating and gold plating of $1.27\mu\text{m}$ minimum per MIL-G-45204, Type II, Grade C, Class 1.

4.4.4 Insulator

The insulator parts shall be made of PTFE.

4.4.5 Cable for Variants 17 and 18

The cable used for Variants 17 and 18 shall be PTFE insulated high strength copper with a minimum of $2\mu\text{m}$ of silver plating per ESCC 3901/013 Variant 08 or equivalent.

4.4.6 Heat Shrinkable Strain Relief Sleeve

The heat shrinkable strain relief shall be made of Viton.

4.4.7 Magnetism Level

Not applicable.

4.5 MARKING

4.5.1 General

The marking of components delivered to this specification shall be in accordance with the requirements of ESCC Basic Specification No. 21700 and the following paragraphs.

The information to be marked and the order of precedence, shall be as follows:

- (a) The ESCC Component Number.
- (b) Traceability Information

4.5.2 The ESCC Component Number

The ESCC Component Number shall be constituted and marked as follows:

340107901B

- Detail Specification Reference: 340079
- Type Variant (See Table 1(a)): 01
- Testing Level: B

4.5.3 Characteristics

Not applicable.

4.5.4 Traceability Information

Each component shall be marked in respect of traceability information in accordance with the requirements of ESCC Basic Specification No. 21700.

4.6 ELECTRICAL MEASUREMENTS

4.6.1 Electrical Measurements at Room Temperature

The parameters to be measured in respect of electrical characteristics are scheduled in Table 2. Unless otherwise specified, measurements shall be performed at $T_{amb}=+22\pm 3^{\circ}\text{C}$.

4.6.2 Electrical Measurements at High and Low Temperatures

Not applicable.

4.6.3 Circuits for Electrical Measurements

Not applicable.

4.7 BURN-IN AND ELECTRICAL MEASUREMENTS

Not applicable.

4.8 ENVIRONMENTAL AND ENDURANCE TESTS

4.8.1 Measurements and Inspections on Completion of Environmental Tests

The parameters to be measured and inspections to be performed on completion of environmental tests are scheduled in Table 6. Unless otherwise stated, the measurements shall be performed at $T_{amb}=+22\pm 3^{\circ}\text{C}$.

4.8.2 Measurements and Inspections at Intermediate Points During Endurance Tests

Not applicable.

4.8.3 Measurements and Inspections on Completion of Endurance Tests

The parameters to be measured and inspections to be performed on completion of endurance tests are scheduled in Table 6. Unless otherwise stated, the measurements shall be performed at $T_{amb}=+22\pm 3^{\circ}\text{C}$.

4.8.4 Conditions for Operating Life (Part of Endurance Testing)

Not applicable.

4.8.5 Electrical Circuit for Operating Life

Not applicable.

4.8.6 Conditions for High Temperature Storage Test (Part of Endurance Testing)

The requirements for the high temperature storage test are specified in Section 9 of ESCC Generic specification No. 3401. The conditions for high temperature storage testing shall be the maximum storage temperature specified in Table 1(b) of this specification.

TABLE 2 - ELECTRICAL MEASUREMENTS AT ROOM TEMPERATURE

No.	Characteristics	Symbol	ESCC 3401 Test Method	Test Conditions	Limits		Unit
					Min	Max	
1	Insulation Resistance	R _i	Para 9.1.1.1	Para. 9.1.1.1 DC Test Note 1	5000	-	MΩ
2	Voltage Proof Leakage Current	I _L	Para 9.1.1.2	900Vrms AC Test Note 1	-	1	mA
3	Low Level Contact Resistance	R _{cl}	Para 9.1.1.3	Para 9.1.1.3 Centre and Intermediate Contacts only	-	8	mΩ
4	Rated Current Contact Resistance	R _{cr}	Para 9.1.1.3	Para 9.1.1.3 Outer Contacts only I=1A	-	20	mΩ
5	Voltage Drop	V _d	-	ECSS-Q-ST-70-26 Para 5.4.2 I=1A	-	2	mV

NOTES:

- 100% tested between the inner contacts during Final Production Tests.

TABLES 3, 4 AND 5

Not applicable.

TABLE 6 - MEASUREMENTS AND INSPECTIONS ON COMPLETION OF ENVIRONMENTAL AND ENDURANCE TESTING

No.	ESCC Generic Spec. No. 3401		Measurements and Inspections		Symbol	Limits		Unit	
	Environmental and Endurance Tests (1)	Test Methods and Conditions	Identification	Conditions		Min	Max		
01	Wiring	Para. 9.10 and Table 1(a) of this spec.	Visual Examination Low Level Contact Resistance Rated Current Contact Resistance Voltage Drop	- Table 2 Item 3 Table 2 Item 4 Table 2 Item 5	- R _{cl} R _{cr} V _d	- Table 2 Item 3 Table 2 Item 4 Table 2 Item 5	-	-	
02	Vibration	Para. 9.11	Initial Measurements (1) Mounting Nut Locking Torque (2) Coupling Torque Final Measurements (1) Mounting Nut Unlocking Torque Drift	Variants 09 through 18 only Variants 09 through 18 only	τ _m τ _c Δτ _m	Table 1(b) Item 5 Record Values Para. 4.3.5 of this spec. Record Values	-25	-	%

No.	ESCC Generic Spec. No. 3401		Measurements and Inspections		Symbol	Limits		Unit
	Environmental and Endurance Tests (1)	Test Methods and Conditions	Identification	Conditions		Min	Max	
			(2) Coupling Torque Drift Visual Examination	-	$\Delta\tau_c$ -	-25 -	+25 -	% -
03	Shock or Bump	Para. 9.12	Initial Measurements (1) Mounting Nut Locking Torque (2) Coupling Torque Final Measurements (1) Mounting Nut Unlocking Torque Drift (2) Coupling Torque Drift Visual Examination	Variants 09 through 18 only Variants 09 through 18 only -	τ_m τ_c $\Delta\tau_m$ $\Delta\tau_c$ -	Table 1(b) Item 5 Record Values Para. 4.3.5 of this spec. Record Values -25 - -25 +25 - -		% %
04	Climatic Sequence	Para. 9.13	Dry Heat Insulation Resistance Low Air Pressure Voltage Proof Leakage Current Damp Heat Insulation Resistance Final Measurements External Visual Inspection Insulation Resistance Voltage Proof Leakage Current	Table 2 Item 1 at high temperature Table 2 Item 2 900Vrms Immediately after test Table 2 Item 1 After 1-24 hrs Recovery ESCC 3401 Para. 9.7 Table 2 Item 1 Table 2 Item 2 900Vrms	Ri I _L Ri - Ri I _L	1000 Table 2 Item 2 100 ESCC 3401 Para. 9.7 Table 2 Item 1 Table 2 Item 2	MΩ MΩ	
05	Seal Test	Para. 9.9	-	-	-	Not applicable		
06	Plating Thickness	Para. 9.14	Thickness	-	-	-	-	
07	Joint Strength Outer Shield Contacts	Para. 9.15 Para. 4.3.13 of this spec. Para. 4.3.14 of this spec.	ESCC 3401 Para. 9.15.5	-	- - -	- -	- -	 Para. 4.3.13 of this spec. Para. 4.3.14 of this spec.
08	Rapid Change of Temperature	Para. 9.16	Visual Examination Insulation Resistance Voltage Proof Leakage Current	- Table 2 Item 1 Table 2 Item 2 900Vrms	- Ri I _L	- -	- -	 Table 2 Item 1 Table 2 Item 2
09	Contact Retention (in insert)	Para. 9.17 & Para. 4.3.4 of this spec.	Contact Displacement	-	D	Para. 4.3.4 of this spec.		
10	Endurance	Para. 9.18	Initial Measurements					

No.	ESCC Generic Spec. No. 3401		Measurements and Inspections		Symbol	Limits		Unit
	Environmental and Endurance Tests (1)	Test Methods and Conditions	Identification	Conditions		Min	Max	
		Para. 9.1.1.4	Mating/Unmating Forces	-	F	Para. 4.3.5 of this spec.		
			Low Level Contact Resistance	Table 2 Item 3	R _{cl}	Table 2 Item 3 Record Values		
		Para. 9.1.1.4	Mated Shell Conductivity	Variants 09 through 18 only	-	-	20	mΩ
			Final Measurements					
			Visual Examination	-	-	-	-	
			Mating/Unmating Forces	After 2 hours minimum recovery	F	Para. 4.3.5 of this spec.		
			Low Level Contact Resistance Drift	Table 2 Item 3	ΔR _{cl}	-	+5	mΩ
		Para. 9.1.1.4	Mated Shell Conductivity Drift	Variants 09 through 18 only	Δ	-	+5	mΩ
			Insulation Resistance	Table 2 Item 1	R _i	Table 2 Item 1		
			Voltage Proof Leakage Current	Table 2 Item 2 900Vrms	I _L	Table 2 Item 2		
11	Permanence of Marking	Para. 9.19	-	-	-	Not applicable		
12	Mating/Unmating Forces	Para. 9.20	Force	-	F	Para. 4.3.5 of this spec.		
13	High Temperature Storage	Para. 9.21	Initial Measurements					
			Low Level Contact Resistance	Table 2 Item 3	R _{cl}	Table 2 Item 3 Record Values		
			Rated Current Contact Resistance	Table 2 Item 4	R _{cr}	Table 2 Item 4 Record Values		
		Para. 9.1.1.4	Mated Shell Conductivity	Variants 09 through 18 only	-	-	20	mΩ
			Final Measurements					
			Visual Examination	-	-	-	-	
			Mating/Unmating Forces	-	F	Para. 4.3.5 of this spec.		
			Low Level Contact Resistance Drift	Table 2 Item 3	ΔR _{cl}	-	+5	mΩ
			Rated Current Contact Resistance Drift	Table 2 Item 4	ΔR _{cr}	-	+5	mΩ
			Insulation Resistance	Table 2 Item 1	R _i	Table 2 Item 1		
			Voltage Proof Leakage Current	Table 2 Item 2 900V _{rms}	I _L	Table 2 Item 2		
			Contact Retention (in insert)	Para. 4.3.4 of this spec.	-	Para. 4.3.4 of this spec.		
		Para. 9.1.1.4	Mated Shell Conductivity Drift	Variants 09 through 18 only	Δ	-	+5	mΩ
14	Corrosion	Para. 9.22	Visual Examination	-	-	-	-	

No.	ESCC Generic Spec. No. 3401		Measurements and Inspections		Symbol	Limits		Unit
	Environmental and Endurance Tests (1)	Test Methods and Conditions	Identification	Conditions		Min	Max	
15	Insert Retention (in shell)	Para. 9.23 & Para. 4.3.6 of this spec.	-	-	-	Not applicable		
16	Jackscrew Retention	Para. 9.24 & Para. 4.3.7 of this spec.	-	-	-	Not applicable		
17	High Temperature Measurements	Para. 9.25	Insulation Resistance	Table 2 Item 1 at maximum operating temperature	Ri	1000	-	MΩ
18	Overload Test	Para. 9.26	-	-	-	Not applicable		
19	Maintenance Aging	Para. 9.27	-	-	-	Not applicable		
20	Engagement and Separation Forces	Para. 9.28 & Para. 4.3.9 of this spec.	Forces	Para. 4.3.9 of this spec.	-	Para. 4.3.9 of this spec.		
21	Oversize Pin Exclusion	Para. 9.29 & Para. 4.3.10 of this spec.	-	-	-	Not applicable		
22	Probe Damage	Para. 9.30 & Para. 4.3.11 of this spec.	-	-	-	Not applicable		
23	Solderability	Para. 9.31 & Para. 4.3.12 of this spec.	-	-	-	Not applicable		

NOTES:

1. The tests in this Table refer to either Chart IV or V and shall be used as applicable.