



**RESISTORS, HEATER, FLEXIBLE, SINGLE AND
DOUBLE LAYER**

BASED ON TYPE FHK

ESCC Detail Specification No. 4009/003

Issue 1	January 2013
---------	--------------



LEGAL DISCLAIMER AND COPYRIGHT

European Space Agency, Copyright © 2013, All rights reserved.

The European Space Agency disclaims any liability or responsibility, to any person or entity, with respect to any loss or damage caused, or alleged to be caused, directly by the use and application of this ESCC publication.

This publication, without prior permission of the European Space Agency and provided it is not used for a commercial purpose, may be:

- copied in whole, in any medium, without alteration or modification.
- copied in part, in any medium, provided that the ESCC document identification, comprising the ESCC symbol, document number and document issue, is removed.



DOCUMENTATION CHANGE NOTICE

(Refer to <https://escies.org> for ESCC DCR content)

DCR No.	CHANGE DESCRIPTION

TABLE OF CONTENTS

1	GENERAL	5
1.1	SCOPE	5
1.2	APPLICABLE DOCUMENTS	5
1.3	TERMS, DEFINITIONS, ABBREVIATIONS, SYMBOLS AND UNITS	5
1.4	THE ESCC COMPONENT NUMBER AND COMPONENT TYPE VARIANTS	5
1.4.1	The ESCC Component Number	5
1.4.2	Component Type Variants and Range of Components	6
1.4.3	Manufacturer Specific Heater Identification	7
1.5	MAXIMUM RATINGS	8
1.6	PHYSICAL DIMENSIONS AND HEATER OUTLINE	9
1.7	MATERIALS AND FINISHES	10
1.7.1	Heater Resistive Element	10
1.7.2	Protective Coating	10
1.7.3	Terminal Leads	10
1.7.4	Optional Materials	10
2	REQUIREMENTS	10
2.1	GENERAL	10
2.1.1	Deviations from the Generic Specification	11
2.2	MARKING	11
2.3	ROBUSTNESS OF TERMINATIONS	11
2.4	ELECTRICAL MEASUREMENTS AT ROOM, HIGH AND LOW TEMPERATURES	11
2.4.1	Room Temperature Electrical Measurements	12
2.4.2	High and Low Temperatures Electrical Measurements	12
2.5	INTERMEDIATE AND END-POINT ELECTRICAL MEASUREMENTS	13
2.6	BURN-IN CONDITIONS	14
2.7	OPERATING LIFE CONDITIONS	14

1 GENERAL

1.1 SCOPE

This specification details the ratings, physical and electrical characteristics, and test and inspection data for the component type variants and/or the range of components specified below. It supplements the requirements of, and shall be read in conjunction with, the ESCC Generic Specification listed under Applicable Documents.

1.2 APPLICABLE DOCUMENTS

The following documents form part of this specification and shall be read in conjunction with it:

- (a) ESCC Generic Specification No. 4009.
- (b) ASTM-D5213: Standard Specification for Polymeric Resin Film for Electrical Insulation and Dielectric Applications.
- (c) IPC4203/1: Adhesive Coated Dielectric Films for Use as Cover Sheets for Flexible Printed Circuitry and Flexible Adhesive Bonding Films.

1.3 TERMS, DEFINITIONS, ABBREVIATIONS, SYMBOLS AND UNITS

For the purpose of this specification, the terms, definitions, abbreviations, symbols and units specified in ESCC Basic Specification No. 21300 shall apply.

1.4 THE ESCC COMPONENT NUMBER AND COMPONENT TYPE VARIANTS

1.4.1 The ESCC Component Number

The ESCC Component Number shall be constituted as follows:

Example: 400900301XYZ1234

- Detail Specification Reference: 4009003
- Component Type Variant Number: 01 (as required)
- Manufacturer Specific Heater Identification: XYZ1234 (as applicable) where:
 - A: First letter of the applicable Manufacturer's name
 - XYZ1234: A unique reference allocated by the Manufacturer to a specific heater design.

1.4.2 Component Type Variants and Range of Components

The component type variants and range of components applicable to this specification are as follows:

Variant Number	Insulation Type (Note 1)	Physical Configuration & Electrical Characteristics	Rated Power Density (W/cm ²) (Note 3)	Maximum Operating / Storage Temperature (°C) (Note 3)	Weight Max (g)
01	Polyimide Film/Acrylic Adhesive	See Note 2	0.38	+150	See Note 4
02	Polyimide Film/FEP	See Note 2	0.54	+200	See Note 4
03	Polyimide Film/FEP plus Acrylic Adhesive Patch	See Note 2	0.38	+150	See Note 4

NOTES:

1. See Materials and Finishes.
2. Available options including the specification of the physical configuration and the electrical characteristics for a specific heater design are as follows:

Physical Configuration		Available Options	
Heating Area S (cm ²)		0.26 to 1000 (see Physical Dimensions and Heater Outline)	
Number of Heater Resistive Elements and Heater Layers		1 Element, Single Layer	
		2 or more Elements, Single Layer	
		2 Elements, Double Layer (1 element in each layer)	
Terminal Leads		1 Element, Double Layer (1 element in each layer, connected to form a single element)	
		Configuration	
		Straight Pair Leads	
		Unjacketed Twisted Pair Leads	
		Jacketed Twisted Pair Leads	
		Shielded Twisted Pair Leads	
Wire Gauge (AWG)		20, 22, 24, 26, 28, 30	
Length		≥ 150mm (see Physical Dimensions and Heater Outline)	
Heater Backing		Not Applied	
		Applied (See Materials and Finishes)	
Pressure Sensitive Adhesive (with Release Liner)		Not Applied	
		Applied (See Materials and Finishes)	

Electrical Characteristics	Available Options
Resistance Range (Ω)	1 to 5000
Resistance Tolerance (± %)	1 to 10
Resistance Density (Ω/cm ²)	0.1 to 70

Other Characteristics	Available Options
Non-Magnetic Heater Resistive Element	Not Applied
	Applied (See Materials and Finishes)

3. See Maximum Ratings
4. The maximum weight of the heaters, excluding the weight of the terminal leads, shall be:
 - 50 mg/cm² for single layer heaters
 - 75 mg/cm² for double layer heaters
 - Add 30 mg/cm² for heater backing
 - Add 10 mg/cm² for pressure sensitive adhesive

The weight of the terminal leads shall be as specified in the applicable wire ESCC Detail Specification.

1.4.3 Manufacturer Specific Heater Identification

A Heater Design Drawing shall be produced by the Manufacturer after negotiation with the Orderer, and shall be held under configuration control by the Manufacturer who will allocate a unique Manufacturer Specific Heater Identification when a request for a heater is received.

Each Heater Design Drawing shall detail the selected options applicable to the heater design, as specified in Component Type Variants and Range of Components, and include the following information as a minimum:

- (a) The heater outline and dimensions as required by Physical Dimensions and Heater Outline herein. This shall include details for the heater layer(s) and heater resistive element(s), as well as specify the terminal leads' configuration and identification, plus the angle of exit of each terminal lead with respect to the heater body.
- (b) The ESCC Component Number for the heater, including the Manufacturer Specific Heater Identification.
- (c) The terminal leads' ESCC Detail Specification and ESCC Component Number.
- (d) The heater electrical information as follows:
 - Resistance value R_n and tolerance by circuit at $T_{amb} = +22 \pm 3^\circ\text{C}$.
 - Maximum rated power in still air at $T_{amb} = +25^\circ\text{C}$.
- (e) Track width and spacing with tolerances.
- (f) Heater backing details (if fitted)
- (g) Pressure sensitive adhesive details (if fitted).
- (h) If a non-magnetic heater resistive element is specified or not (the heater resistive element material)

1.5 MAXIMUM RATINGS

The maximum ratings shall not be exceeded at any time during use or storage.

Maximum ratings shall only be exceeded during testing to the extent specified in this specification and when stipulated in Test Methods and Procedures of the ESCC Generic Specification.

Characteristics	Symbols	Maximum Ratings	Units	Remarks
Rated Power Density Variants 01, 03 Variant 02	P_n	0.38 0.54	W/cm ²	Notes 1, 2, 3, 5 Notes 1, 2, 4, 5
Rated Voltage	U_R	$\sqrt{(P_n \cdot R_n \cdot S)}$	V	Notes 2, 6
Operating Temperature Range Variants 01, 03 Variant 02	T_{op}	-65 to +150 -65 to +200	°C	T_{amb} Note 3 Note 4
Storage Temperature Range Variants 01, 03 Variant 02	T_{stg}	-65 to +150 -65 to +200	°C	

NOTES:

1. With heater suspended in still air at $T_{amb} \leq +25^\circ\text{C}$
2. Actual rated power shall be specified in the applicable Heater Design Drawing. It shall be determined from the Heating Area (S) in cm².
3. Derate to 0W/cm² at 0.00304W/cm²/°C for $+25^\circ\text{C} < T_{amb} \leq +150^\circ\text{C}$.
4. Derate to 0W/cm² at 0.00308W/cm²/°C for $+25^\circ\text{C} < T_{amb} \leq +200^\circ\text{C}$.
5. The following design rule shall be applied:
 - Area of Heater Resistive Element / Heating Area (S) = 50 ±10%
6. R_n is the nominal resistance.

1.6 PHYSICAL DIMENSIONS AND HEATER OUTLINE

The general physical dimensions and heater layout shall be as follows. The physical dimensions and heater layout applicable to a specific heater will be specified in the Heater Design Drawing held by the Manufacturer.

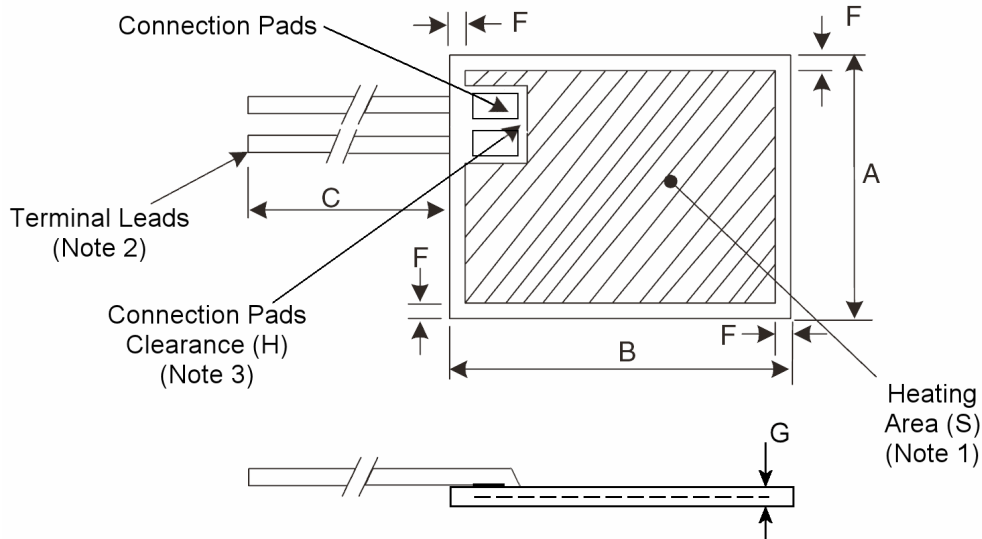

Symbols	Dimensions mm		Tolerance	Remarks
	Min	Max		
A	6.4	250	±0.5mm	Notes 1, 4
B	6.4	400	±0.5mm	Notes 1, 4
C	150	-	±10%	Notes 2, 4
F	0.76	-	-	Notes 5, 6
G	-	0.2	-	Notes 7, 9
	-	0.3	-	Notes 8, 9
H	0.3	-	-	Note 3

NOTES:

1. The Heating Area, S, is defined as the total area of the heater excluding the peripheral margin and the terminal leads connection pads area. The acceptable limits of S are specified in Component Type Variants and Range of Components.
2. The terminal leads' configuration, wire gauge and lead length options are specified in Component Type Variants and Range of Components
3. The minimum clearance between the connection pads, and between the connection pads and any part of the heater resistive element.
4. The tolerance shall apply to the actual required dimension.
5. Peripheral margin dimension between the outer edge of the heater and the heater resistive element or the connection pads.
6. Perforated holes in the peripheral margin are allowed provided that the distance between the edge of the hole and the heater resistive element or connection pad is equal to or greater than dimension F.
7. For single layer heaters. Maximum limit does not apply over the terminal lead connection pad area.
8. For double layer heaters. Maximum limit does not apply over the terminal lead connection pad area.
9. Add 0.1mm for heater backing, if fitted. Add 0.06mm for pressure sensitive adhesive (excluding the release liner), if fitted.

1.7 MATERIALS AND FINISHES

1.7.1 Heater Resistive Element

The heater resistive element shall be made of nickel/chromium/iron alloy.

When the heater is specified as non-magnetic, the heater resistive element shall be made of nickel/chromium alloy.

1.7.2 Protective Coating

Heater resistive elements and the terminal lead connection pad area shall be completely covered with insulation. The insulation type, as is specified in Component Type Variants and Range of Components, shall be as follows:

- Variant 01: Polyimide Film/Acrylic Adhesive: in accordance with IPC4203/1.
- Variant 02: Polyimide Film/FEP: in accordance with ASTM-D5213.
- Variant 03: Polyimide Film/FEP plus Acrylic Adhesive Patch: Heater resistive elements shall be completely covered with Polyimide Film/FEP accordance with ASTM-D5213. The terminal lead connection pad area shall be completely covered with a patch of polyimide film/acrylic adhesive in accordance with IPC4203/1.

1.7.3 Terminal Leads

Terminal leads shall be made of multi-strand silver-plated copper in accordance with ESCC Generic Specification No. 3901. The applicable Heater Design Drawing shall specify the wire ESCC Detail Specification and the wire ESCC Component Number. The wire gauge shall be as specified in Component Type Variants and Range of Components herein. Terminal leads shall be electrically welded to the heater resistive element.

1.7.4 Optional Materials

- (a) Heater Backing (if fitted): Al foil, 76.2 μ m thickness.
- (b) Pressure Sensitive Adhesive (if fitted): as specified in the PID. Pressure sensitive adhesive shall be considered as an accessory to the heater. The use of pressure sensitive adhesive may reduce the operating and storage temperature range of the heater. Pressure sensitive adhesive will have a limited shelf life.

2 REQUIREMENTS

2.1 GENERAL

The complete requirements for procurement of the components specified herein are as stated in this specification and the ESCC Generic Specification. Permitted deviations from the Generic Specification, applicable to this specification only, are listed below.

Permitted deviations from the Generic Specification and this Detail Specification, formally agreed with specific Manufacturers on the basis that the alternative requirements are equivalent to the ESCC requirement and do not affect the component's reliability, are listed in the appendices attached to this specification.

2.1.1 Deviations from the Generic Specification

2.1.1.1 *Deviations from Screening Tests - Chart F3*

(a) For heaters where the Heater Design Drawing requires the application of pressure sensitive adhesive, the following additional steps shall be performed during Screening Tests:

- An additional 100% External Visual Inspection shall be performed after successful completion of High and Low Temperatures Electrical Measurements.
- After successful completion of the additional External Visual Inspection the pressure sensitive adhesive shall be applied to the heater.

NOTE:

For heaters which already have heater backing applied, the additional External Visual Inspection shall not be performed.

2.2 MARKING

The marking shall be in accordance with the requirements of ESCC Basic Specification No. 21700 and as follows.

The information to be marked on the component shall be:

- (a) The ESCC qualified components symbol (for ESCC qualified components only).
- (b) The ESCC Component Number.
- (c) Traceability information.

2.3 ROBUSTNESS OF TERMINATIONS

The test conditions for Robustness of Terminations shall be as specified in the ESCC Generic Specification and as follows and apply to a single lead at a time:

Test Condition	Wire Gauge (AWG)					
	20	22	24	26	28	30
Pull Strength (N)	45	36	22	13	9	4.5
Duration (s) minimum	5	5	5	5	5	5

2.4 ELECTRICAL MEASUREMENTS AT ROOM, HIGH AND LOW TEMPERATURES

Electrical measurements shall be performed at room, high and low temperatures.

2.4.1 Room Temperature Electrical Measurements

The measurements shall be performed at $T_{amb} = +22 \pm 3^{\circ}C$.

Characteristics	Symbols	Test Method and Conditions	Tolerance (\pm %)	Limits		Units
				Min	Max	
Resistance	R_A	ESCC No. 4009	1 to 10 (1)	$R_n - T\%$	$R_n + T\%$	Ω
Insulation Resistance	R_I	ESCC No. 4009	All	1000	-	$M\Omega$
Voltage Proof Leakage Current	I_L	ESCC No. 4009 Test Voltage = 500Vrms	All	-	1 or (2) 5	mA $\mu A/cm^2$

NOTES:

1. Where T is the applicable tolerance.
2. Whichever is greater based on the Heating Area (S).

2.4.2 High and Low Temperatures Electrical Measurements

Characteristics	Symbols	Test Method and Conditions (Note 1)	Limits		Units
			Min	Max	
Resistance Change between $+22 \pm 3^{\circ}C$ and $-65 (+3 -0)^{\circ}C$	$\Delta R_A/R_A(L)$	ESCC No. 4009	0	-1.57	%
Resistance Change between $+22 \pm 3^{\circ}C$ and $+150 (+0 -3)^{\circ}C$	$\Delta R_A/R_A(H)$	ESCC No. 4009 Variants 01, 03 only	0	+2.29	%
Resistance Change between $+22 \pm 3^{\circ}C$ and $+200 (+0 -3)^{\circ}C$	$\Delta R_A/R_A(H)$	ESCC No. 4009 Variant 02 only	0	+3.17	%

NOTES:

1. The measurements shall be performed during Screening Tests on a sample of 3 components. In the event of any failure a 100% inspection shall be performed.

2.5 INTERMEDIATE AND END-POINT ELECTRICAL MEASUREMENTS

Unless otherwise specified, the measurements shall be performed at $T_{amb} = +22 \pm 3^{\circ}\text{C}$.

The test methods and test conditions shall be as per the corresponding test defined in Room Temperature Electrical Measurements.

Test Reference per ESCC No. 4009	Characteristics	Symbols	Limits		Units	
			Min	Max		
Robustness of Terminations Initial Measurements	Resistance	R_A	Note 1			
	Final Measurements	R_A	Note 1			
	Change in Resistance	$\Delta R_A/R_A$	-1	+1	%	
Climatic Sequence Initial Measurements	Resistance	R_A	Note 1			
	Final Measurements	R_A	Note 1			
	Change in Resistance	$\Delta R_A/R_A$	-1	+1	%	
	Insulation Resistance	R_i	Note 1			
	Voltage Proof Leakage Current	I_L	Note 1			
Operating Life Initial Measurements (0 hours)	Resistance	R_A	Note 1			
	Intermediate Measurements (1000 hours)	Resistance	R_A	Note 1		
		Change in Resistance	$\Delta R_A/R_A$	-1.4	+1.4	%
	Final Measurements (2000 hours)	Resistance	R_A	Note 1		
		Change in Resistance (related to 0 hours)	$\Delta R_A/R_A$	-2	+2	%
		Insulation Resistance	R_i	Note 1		
	Voltage Proof Leakage Current	I_L	Note 1			

NOTES:

1. As specified in Room Temperature Electrical Measurements.

2.6 BURN-IN CONDITIONS

Characteristics	Symbols	Test Conditions	Units
Heater Temperature Variants 01, 03 Variant 02	T_{HTR}	+150 (Note 1) +200 (Note 1)	°C
Power Density Variants 01, 03 Variant 02	P_n	0.38 (Note 1) 0.54 (Note 1)	W/cm ²

NOTES:

1. Voltage shall be applied until either the specified heater temperature or the power density is reached.

2.7 OPERATING LIFE CONDITIONS

The conditions shall be as specified for Burn-in.