



**CONNECTORS, ELECTRICAL, CIRCULAR,  
BAYONET COUPLING, REMOVABLE CRIMP  
CONTACTS**

**BASED ON MIL-C-38999 SERIES II**

**ESCC Detail Specification No. 3401/044**

Issue 2	February 2013
---------	---------------



**LEGAL DISCLAIMER AND COPYRIGHT**

European Space Agency, Copyright © 2013, All rights reserved.

The European Space Agency disclaims any liability or responsibility, to any person or entity, with respect to any loss or damage caused, or alleged to be caused, directly by the use and application of this ESCC publication.

This publication, without prior permission of the European Space Agency and provided it is not used for a commercial purpose, may be:

- copied in whole, in any medium, without alteration or modification.
- copied in part, in any medium, provided that the ESCC document identification, comprising the ESCC symbol, document number and document issue, is removed.

**DOCUMENTATION CHANGE NOTICE**

(Refer to <https://escies.org> for ESCC DCR content)

DCR No.	CHANGE DESCRIPTION
750	Specification updated to incorporate editorial changes per DCR.

**TABLE OF CONTENTS**

1	GENERAL	6
1.1	SCOPE	6
1.2	RANGE OF COMPONENTS	6
1.3	MAXIMUM RATINGS	6
1.4	PARAMETER DERATING INFORMATION	6
1.5	PHYSICAL DIMENSIONS	6
2	APPLICABLE DOCUMENTS	6
3	TERMS, DEFINITIONS, ABBREVIATIONS, SYMBOLS AND UNITS	15
4	REQUIREMENTS	15
4.1	GENERAL	15
4.2	DEVIATIONS FROM GENERIC SPECIFICATION	15
4.2.1	Deviations from Special In-process Controls	15
4.2.2	Deviations from Final Production Tests (Chart II)	15
4.2.3	Deviations from Burn-in and Electrical Measurements (Chart III)	15
4.2.4	Deviations from Qualification Tests (Chart IV)	15
4.2.5	Deviations from Lot Acceptance Tests (Chart V)	15
4.3	MECHANICAL REQUIREMENTS	16
4.3.1	Dimension Check	16
4.3.2	Weight	16
4.3.3	Contact Capability	16
4.3.4	Contact Retention (In Insert)	16
4.3.5	Mating and Unmating Forces	16
4.3.6	Insert Retention (In Shell)	16
4.3.7	Jackscrew Retention	16
4.3.8	Contact Insertion and Withdrawal Forces	16
4.3.9	Engagement and Separation Forces	16
4.3.10	Oversize Pin Exclusion	16
4.3.11	Probe Damage	16
4.3.12	Solderability	16
4.4	MATERIALS AND FINISHES	16
4.4.1	Shell, Coupling Ring and Nuts	17
4.4.2	Inserts	17
4.4.3	Contacts	17
4.4.4	Contact Retaining Clip	17
4.4.5	Guiding and Locking Devices	17

4.4.6	Magnetism Level	17
4.5	MARKING	17
4.5.1	General	17
4.5.2	Contact Identification	17
4.5.3	The ESCC Component Number	17
4.5.4	Characteristics	17
4.5.5	Traceability Information	19
4.5.6	Marking of Small Components	19
4.6	ELECTRICAL MEASUREMENTS	19
4.6.1	Electrical Measurements at Room Temperature	19
4.6.2	Electrical Measurements at High and Low Temperatures (Table 3)	19
4.6.3	Circuit for Electrical Measurements (Figure 4)	19
4.7	BURN-IN AND ELECTRICAL MEASUREMENTS (TABLES 4 AND 5)	19
4.8	ENVIRONMENTAL AND ENDURANCE TESTS	20
4.8.1	Measurements and Inspections on Completion of Environmental Tests	20
4.8.2	Measurements and Inspections at Intermediate Points during Endurance Tests	20
4.8.3	Measurements and Inspections on Completion of Endurance Tests	20
4.8.4	Conditions for Operating Life Test (Part of Endurance Testing)	20
4.8.5	Electrical Circuits for Operating Life Test	20
4.8.6	Conditions for High Temperature Storage Test (Part of Endurance Testing)	20

## **1**      **GENERAL**

### **1.1**      **SCOPE**

This specification details the ratings, physical and electrical characteristics, test and inspection data for Connectors, Electrical, Circular, Bayonet Coupling, Removable Crimp Contacts, Based on MIL-C-38999 Series II. It shall be read in conjunction with:

- ESCC Generic Specification No. 3401, Connectors, Electrical, Non-Filtered, Circular and Rectangular
- ESCC Detail Specification No. 3401/045, Contacts, Electrical, Crimp, for 3401/044 Connectors
- ESCC Detail Specification No. 3401/062, Accessories for Circular Connectors 3401/044, 3401/052 and 3401/056

the requirements of which are supplemented herein.

### **1.2**      **RANGE OF COMPONENTS**

The different sizes of connectors specified herein, which are also covered by this specification, together with their mechanical characteristics, are given in Table 1(a).

### **1.3**      **MAXIMUM RATINGS**

The maximum ratings, which shall not be exceeded at any time during use or storage, applicable to the connectors specified herein, are scheduled in Table 1(b).

### **1.4**      **PARAMETER DERATING INFORMATION**

The applicable derating information for the connectors specified herein is shown in Figure 1.

### **1.5**      **PHYSICAL DIMENSIONS**

The physical dimensions of the connectors specified herein are shown in Figure 2.

## **2**      **APPLICABLE DOCUMENTS**

The following documents form part of this specification and shall be read in conjunction with it:

- (a) ESCC Generic Specification No. 3401, Connectors, Electrical, Non-Filtered, Circular and Rectangular.
- (b) ESCC Detail Specification No. 3401/045, Contacts, Electrical, Crimp, for 3401/044 Connectors.
- (c) ESCC Detail Specification No. 3401/062, Accessories for Circular Connectors 3401/044, 3401/052 and 3401/056.
- (d) MIL-STD-1560, Insert Arrangements for MIL-C-38999 and MIL-C-27599 Electrical Circular Connectors.
- (e) MIL-STD-1344, Test Methods for Electrical Connectors.

**TABLE 1(a) – RANGE OF COMPONENTS**

Shell Style	Shell Size	Max. Weight (g) (1)		Mating Torque Max. (Nm)	Unmating Torque		Tightening Torque for Mounting Nut Shell 07 Max. (Nm)
		Shell Type			Max. (Nm)	Min. (Nm)	
		03	07				
Receptacle	08	6	12	-	-	-	9
Receptacle	10	8	16	-	-	-	11
Receptacle	12	12	21	-	-	-	14
Receptacle	14	14.5	25.5	-	-	-	16
Receptacle	16	17.5	31	-	-	-	18
Receptacle	18	22	35.5	-	-	-	20
Receptacle	20	27	42.5	-	-	-	22
Receptacle	22	32	49	-	-	-	24
Receptacle	24	37	56.6	-	-	-	27
		Shell Type 06					
Plug	08	9		0.9	0.9	0.2	-
Plug	10	11		1.4	1.4	0.2	-
Plug	12	16		1.8	1.8	0.2	-
Plug	14	20		2.3	2.3	0.3	-
Plug	16	24		2.7	2.7	0.3	-
Plug	18	29		3.2	3.2	0.3	-
Plug	20	34		3.6	3.6	0.6	-
Plug	22	39		4.1	4.1	0.6	-
Plug	24	46		4.6	4.6	0.6	-

**NOTES:**

- Without contacts. See ESCC Detail Specification No. 3401/045 for contact weights.

**TABLE 1(b) – MAXIMUM RATINGS**

No.	Characteristics	Symbol	Maximum Rating	Unit
1	Working Voltage (Sea Level) (1) Service rating M Service rating I Service rating II	$U_R$	325 450 575	Vrms
2	Operating Temperature Range	$T_{op}$	-65 to +200	°C
3	Storage Temperature Range	$T_{stg}$	-65 to +200	°C
4	Tightening Torque for Mounting Nut Shell 07	$T_q$	See Table 1(a)	-

**NOTES:**

- See Para. 4.5.4.3.

**FIGURE 1 – PARAMETER DERATING INFORMATION**

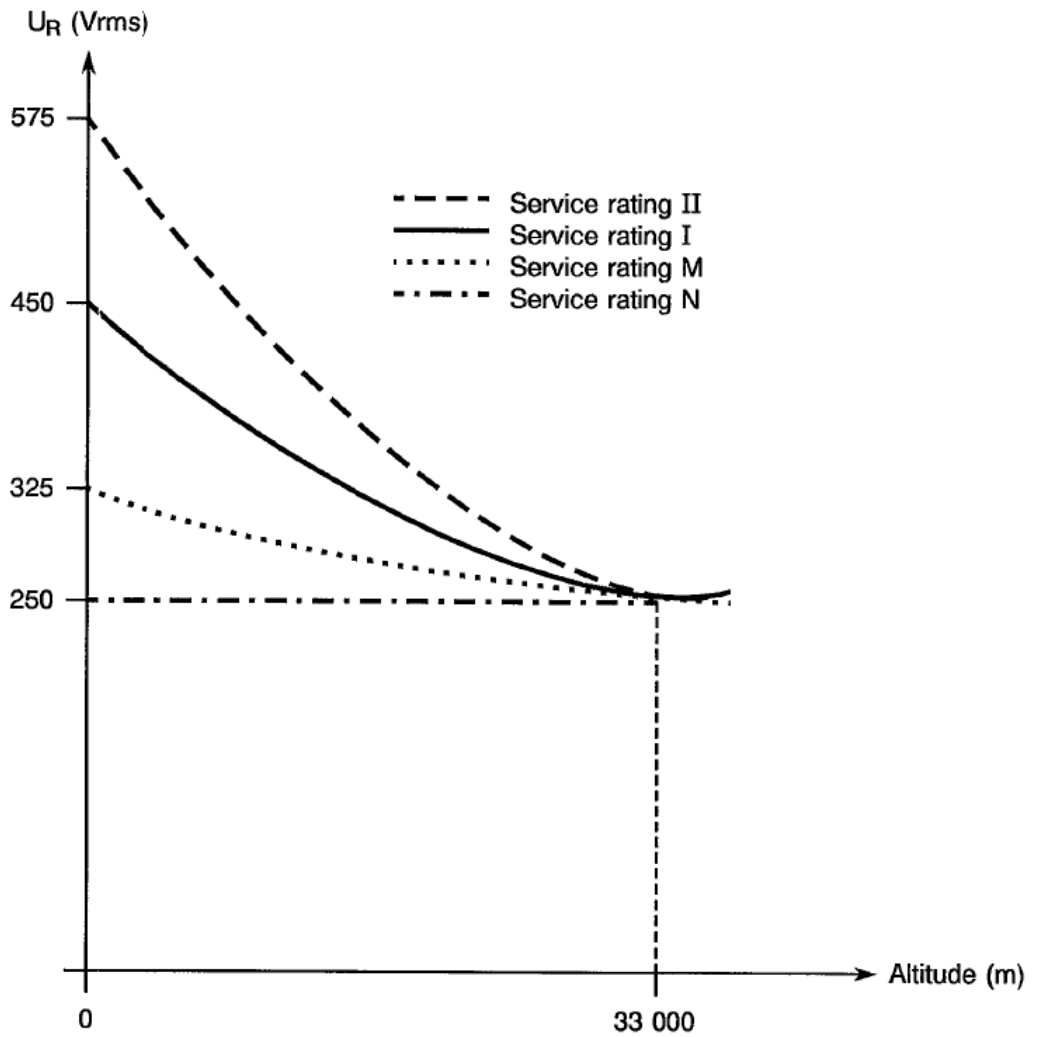

Working Voltage versus Altitude



**FIGURE 2 – PHYSICAL DIMENSIONS**

**FIGURE 2(a) – RECEPTACLES AND PLUGS**

**SHELL TYPE 03: SQUARE FLANGE RECEPTACLE BACK MOUNTING**

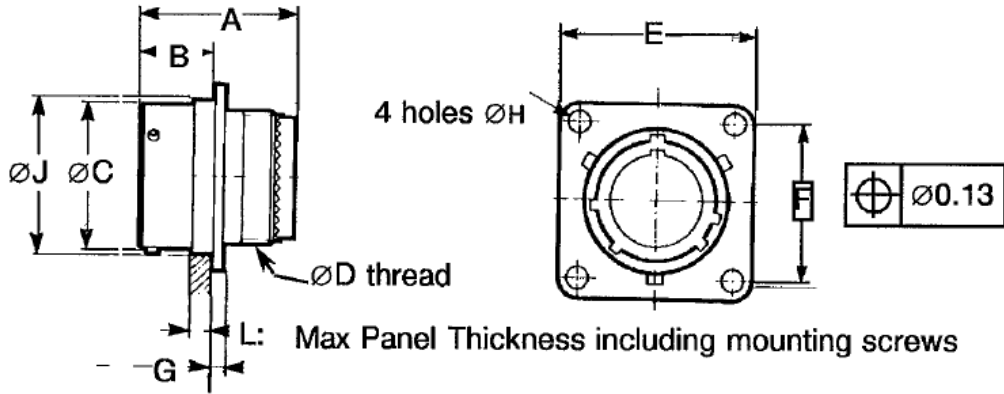

Shell Size	08	10	12	14	16	18	20	22	24
A Max.	25.37	25.37	25.37	25.37	25.37	25.37	25.37	25.37	27.1
B Max.	11.35	11.35	11.35	11.35	11.35	11.35	11.35	11.35	11.35
$\varnothing C$ Max.	12.04	15.02	19.08	22.25	25.43	28.61	31.78	34.95	38.13
$\varnothing D$ UNEF-2A	.4375-28	.5625-24	.6875-24	.8125-20	.9375-20	1.0625-18	1.1875-18	1.3125-18	1.4375-18
E Max.	21.03	24.23	26.59	28.98	31.34	33.73	36.91	40.08	43.26
F	15.09	18.26	20.62	23.01	24.61	26.97	29.36	31.75	34.93
G Max.	1.75	1.75	1.75	1.75	1.75	1.75	1.75	1.75	1.75
$\varnothing H$ Max.	3.3	3.3	3.3	3.3	3.3	3.3	3.3	3.3	3.99
$\varnothing J$ Max.	13.89	17.07	21.44	24.61	27.79	30.96	34.14	37.31	40.49
L Max.	3.71	3.71	3.71	3.71	3.71	3.71	4.27	4.27	4.27

**NOTES:**

1. All dimensions are in millimetres, except thread  $\varnothing D$  in inches.

**SHELL TYPE 06: PLUG**

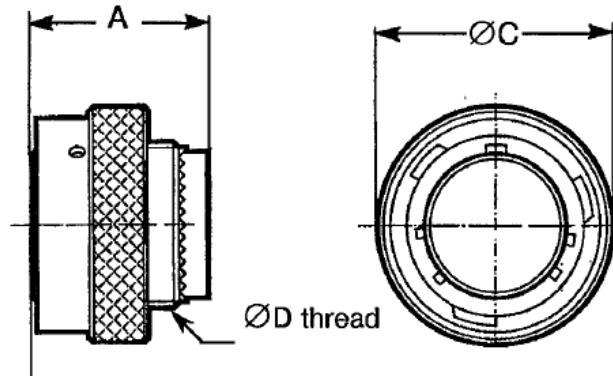

Shell Size	08	10	12	14	16	18	20	22	24
A Max.	23.27	23.27	23.27	23.27	23.27	23.27	23.27	23.27	25
ØC Max.	19.05	21.82	26.19	29.36	32.54	35.71	38.89	41.68	44.86
ØD UNEF-2A	.4375-28	.5625-24	.6875-24	.8125-20	.9375-20	1.0625-18	1.1875-18	1.3125-18	1.4375-18

**NOTES:**

1. All dimensions are in millimetres, except thread ØD in inches.

**SHELL TYPE 07: SINGLE HOLE MOUNTING RECEPTACLE**

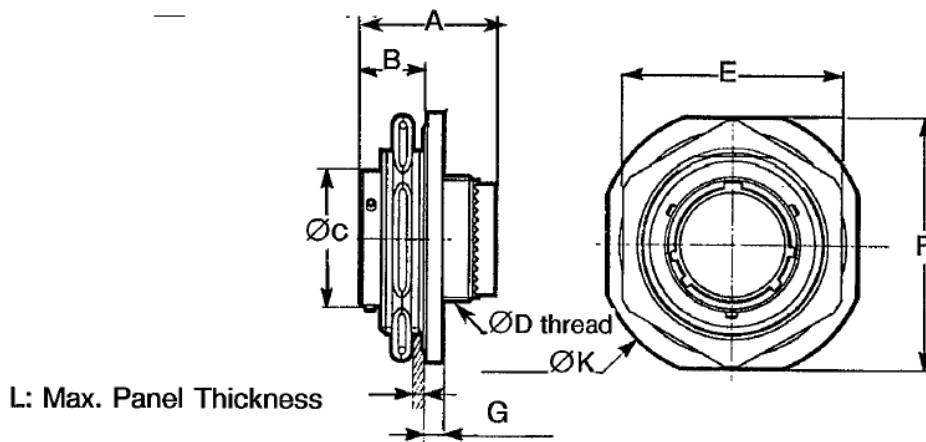

Shell Size	08	10	12	14	16	18	20	22	24
A Max.	26.48	26.48	26.48	26.48	26.48	26.48	26.32	26.32	27.67
B Max.	11.26	11.26	11.26	11.26	11.26	11.26	11.92	11.92	11.92
ØC Max.	12.04	15.02	19.08	22.25	25.43	28.61	31.78	34.95	38.13
ØD UNEF-2A	.4375-28	.5625-24	.6875-24	.8125-20	.9375-20	1.0625-18	1.1875-18	1.3125-18	1.4375-18
E Max.	27.4	30.61	33.75	36.96	40.1	43.31	46.45	51.23	54.41
F Max.	32.16	35.34	38.51	41.69	45.65	48.42	51.62	54.77	57.94
G Max.	2.67	2.67	2.67	2.67	2.67	2.67	2.67	2.67	2.67
ØK Max.	35.34	38.51	41.69	44.86	49.64	51.62	54.79	57.94	61.12
L Max.	2.9	2.9	2.9	2.9	2.9	2.9	2.9	2.9	2.9

**NOTES:**

1. All dimensions are in millimetres, except thread ØD in inches.

FIGURE 2(b) – HIGH DENSITY CONTACT ARRANGEMENTS – FRONT VIEW MALE INSERT

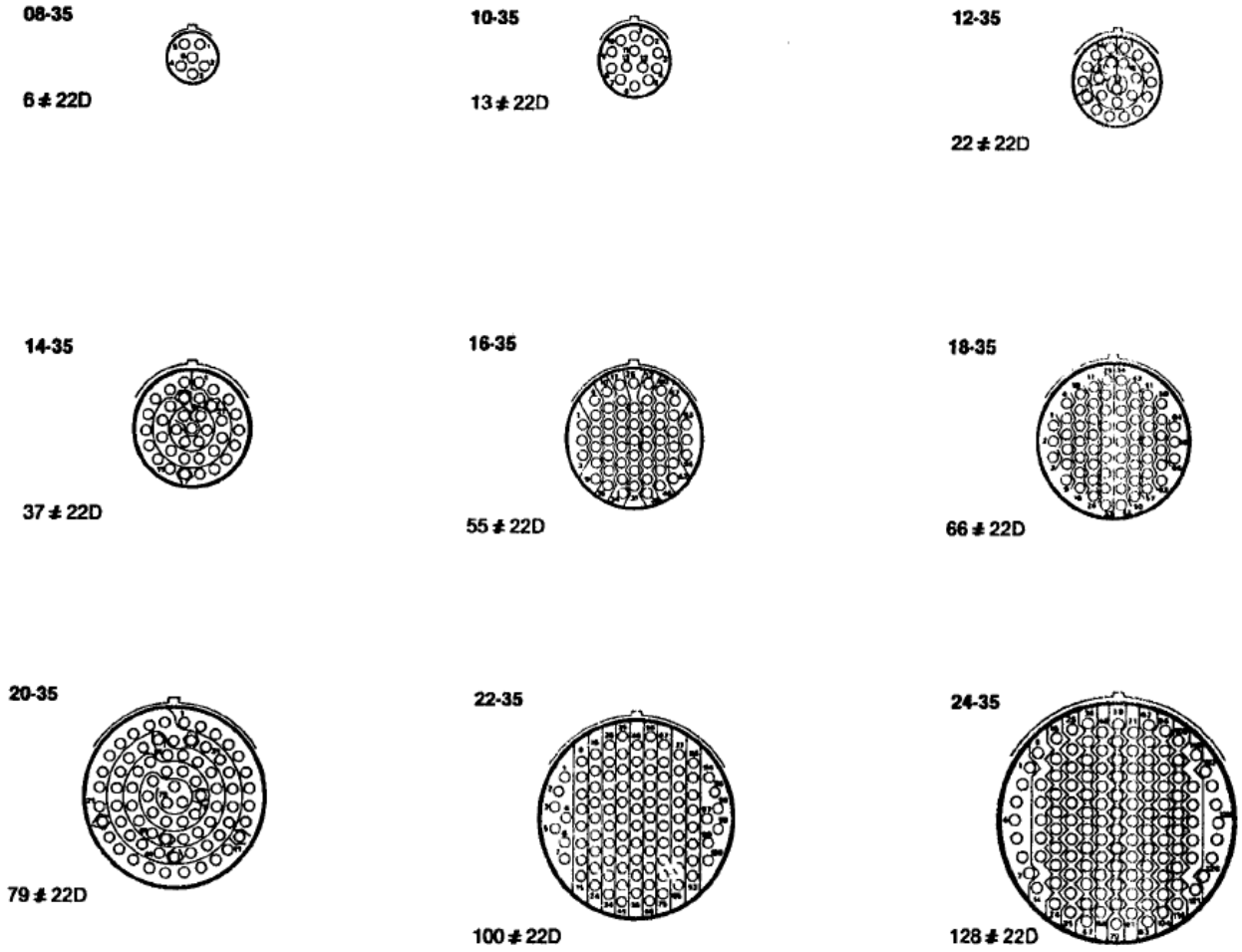

**NOTES:**

1. Contact locations and identifications are in conformity with MIL-STD-1560.
2. Both sides of the inserts shall be marked.

FIGURE 2(b) – STANDARD CONTACT ARRANGEMENTS – FRONT VIEW MALE INSERT

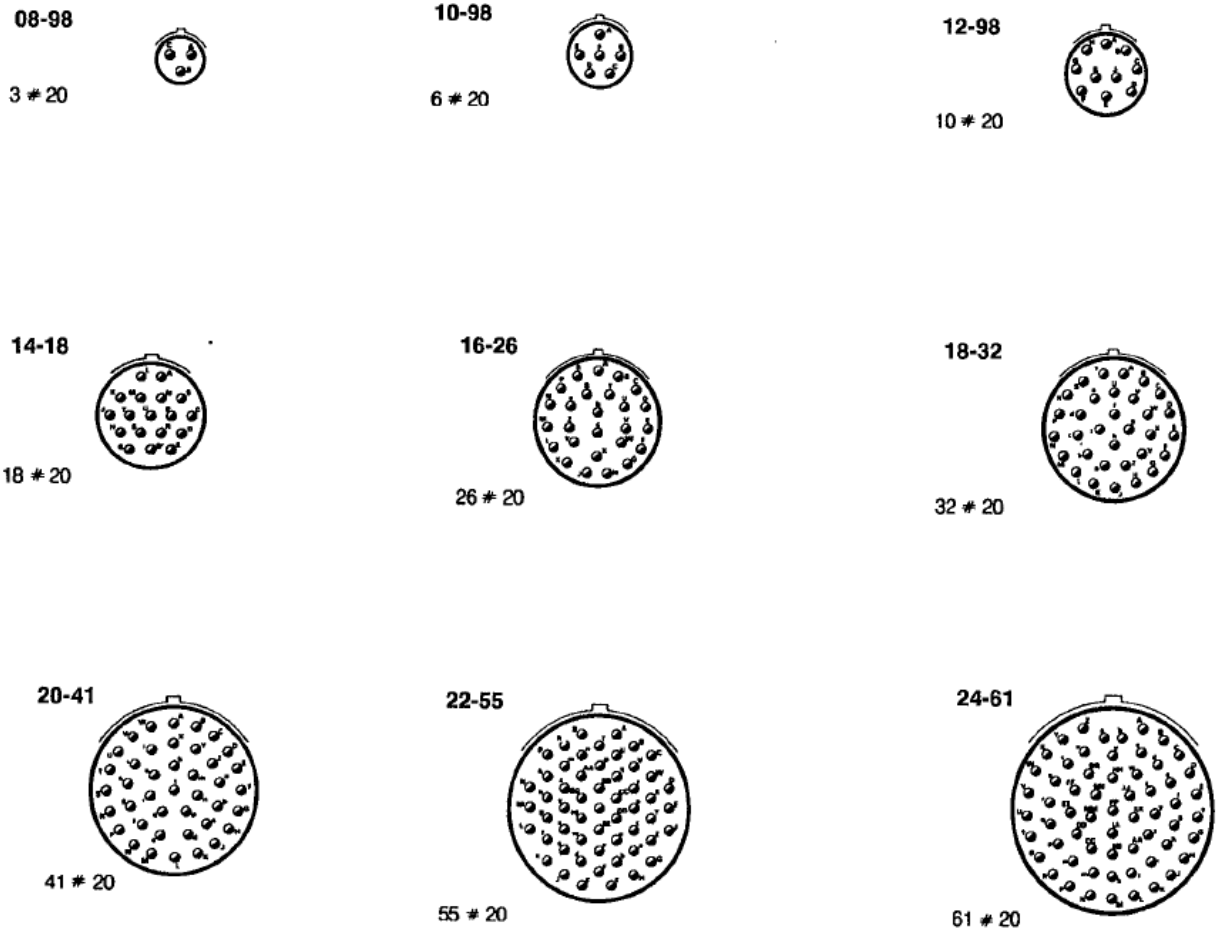

**NOTES:**

1. Contact locations and identifications are in conformity with MIL-STD-1560.
2. Both sides of the inserts shall be marked.

**FIGURE 2(b) – SPECIAL CONTACT ARRANGEMENTS – FRONT VIEW MALE INSERT**

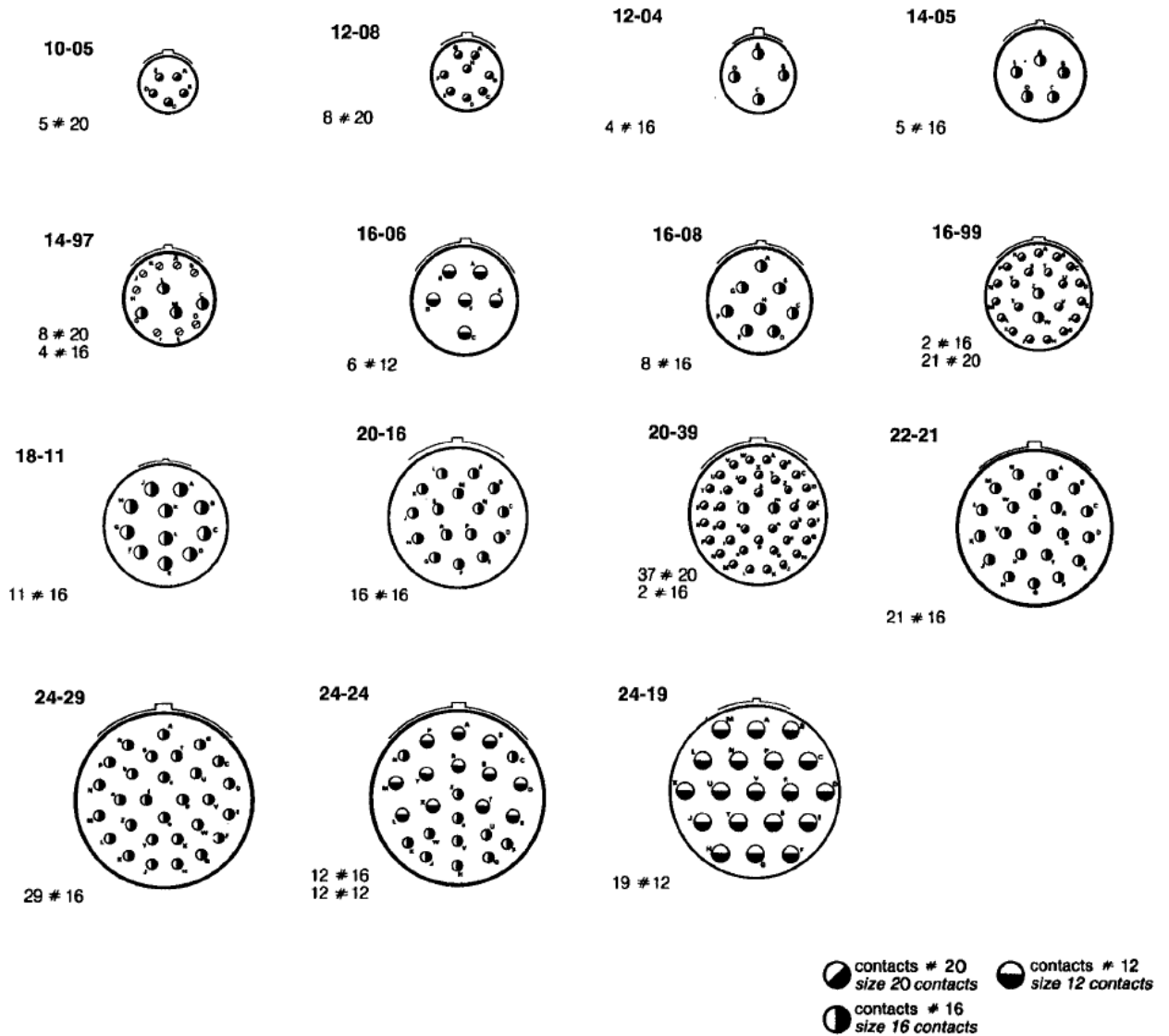

**NOTES:**

1. Contact locations and identifications are in conformity with MIL-STD-1560.
2. Both sides of the inserts shall be marked.

FIGURE 2(c) – CLOCKING POSITIONS

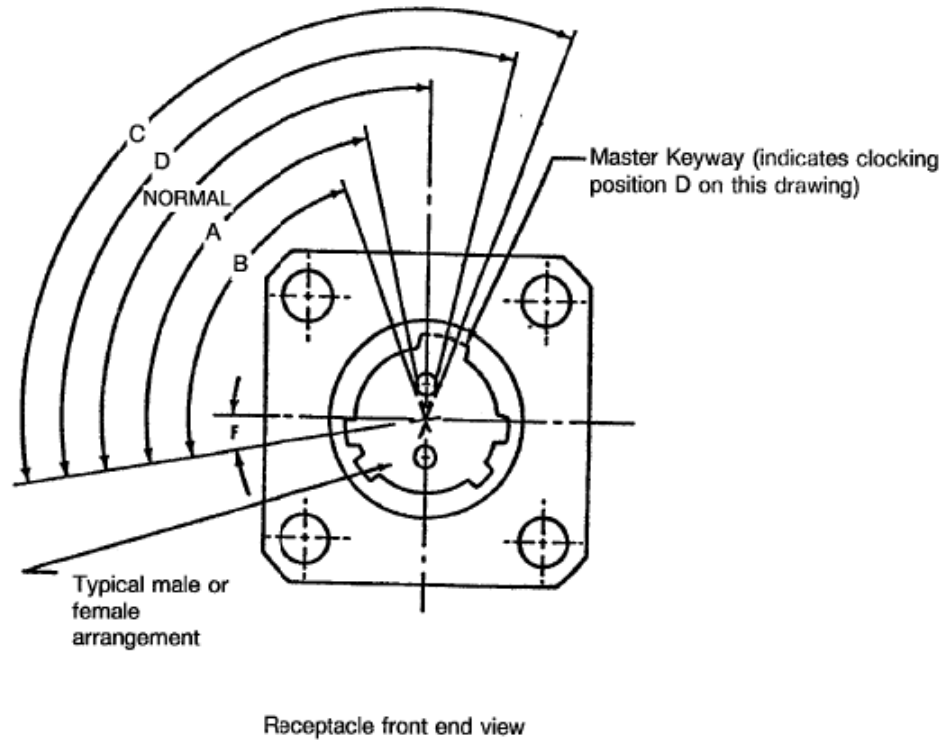

Receptacle front end view

**NOTES:**

1. The clocking position is determined by the master keyway position, the insert being always in the same position. The secondary keyway positions remain fixed.

Shell Size	F (Ref.)	Normal Position	Clocking Positions (°)			
			A	B	C	D
08	10°	100°	82	-	-	118
10	10°	100°	86	72	128	114
12	10°	100°	80	68	132	120
14	10°	100°	79	66	134	121
16	10°	100°	82	70	130	118
18	10°	100°	82	70	130	118
20	10°	100°	82	70	130	118
22	10°	100°	85	74	126	115
24	10°	100°	85	74	126	115

### 3 TERMS, DEFINITIONS, ABBREVIATIONS, SYMBOLS AND UNITS

For the purpose of this specification, the terms, definitions, abbreviations, symbols and units specified in ESCC Basic Specification No. 21300 shall apply.

### 4 REQUIREMENTS

#### 4.1 GENERAL

The complete requirements for procurement of the connectors specified herein are stated in this specification and ESCC Generic Specification No. 3401. Deviations from the Generic Specification, applicable to this specification only, are listed in Para. 4.2.

Deviations from the applicable Generic Specification and this Detail Specification, formally agreed with specific Manufacturers on the basis that the alternative requirements are equivalent to the ESCC requirements and do not affect the components' reliability, are listed in the appendices attached to this specification.

#### 4.2 DEVIATIONS FROM GENERIC SPECIFICATION

##### 4.2.1 Deviations from Special In-process Controls

None.

##### 4.2.2 Deviations from Final Production Tests (Chart II)

- (a) Para. 9.5, Magnetism Level: Not applicable. Instead, a magnetic permeability test shall be performed in accordance with Method 3006 of MIL-STD-1344. The magnetic permeability of assembled connectors (with contacts and accessories as applicable) shall not exceed  $2 \times \mu_0$ . The test shall be performed on 1 sample per shell size.

##### 4.2.3 Deviations from Burn-in and Electrical Measurements (Chart III)

Chart III is not applicable.

##### 4.2.4 Deviations from Qualification Tests (Chart IV)

- (a) Para. 9.11.2, Sinusoidal Vibration Testing:
- 10-55Hz at 8.25mm double amplitude displacement.
  - 56-2000Hz at 50g.
  - 1 cycle (10-2000-10 Hz) per axis at a sweep rate of 1 octave per minute.
- (b) Para. 9.11.3, Random Vibration Testing:
- 20-100Hz at + 6dB per octave.
  - 100-2000Hz, constant at  $1g^2/Hz$ .
  - 3 axes.
  - 7 minutes per axis.
- (c) Para. 9.12.1, Shock: 75g, 11 milliseconds, half sine wave.
- (d) Para. 9.24, Jackscrew Retention: Not applicable.
- (e) Para. 9.31, Solderability: Not applicable.

##### 4.2.5 Deviations from Lot Acceptance Tests (Chart V)

- (a) Para. 9.31, Solderability: Not applicable.

#### 4.3 MECHANICAL REQUIREMENTS

##### 4.3.1 Dimension Check

The dimensions of the connectors specified herein shall be verified in accordance with the requirements set out in Para. 9.6 of ESCC Generic Specification No. 3401 and shall conform to those shown in Figure 2 of this specification.

##### 4.3.2 Weight

The maximum weight of the connectors specified herein, without contacts, shall be as specified in Table 1(a).

##### 4.3.3 Contact Capability

As specified in ESCC Detail Specification No. 3401/045.

##### 4.3.4 Contact Retention (In Insert)

As specified in ESCC Detail Specification No. 3401/045.

##### 4.3.5 Mating and Unmating Forces

The forces applied for mating and unmating of the connectors shall conform to the values specified in Table 1(a).

##### 4.3.6 Insert Retention (In Shell)

Connector inserts shall withstand a pressure of 53.7N/cm<sup>2</sup> without being dislodged from the shell.

##### 4.3.7 Jackscrew Retention

Not applicable.

##### 4.3.8 Contact Insertion and Withdrawal Forces

As specified in ESCC Detail Specification No. 3401/045.

##### 4.3.9 Engagement and Separation Forces

As specified in ESCC Detail Specification No. 3401/045.

##### 4.3.10 Oversize Pin Exclusion

As specified in ESCC Detail Specification No. 3401/045.

##### 4.3.11 Probe Damage

As specified in ESCC Detail Specification No. 3401/045.

##### 4.3.12 Solderability

Not applicable.

#### 4.4 MATERIALS AND FINISHES

The materials and finishes shall be as specified herein. Where a definite material is not specified, a material which will enable the connectors specified herein to meet the performance requirements of this specification shall be used. Acceptance or approval of any constituent material does not guarantee acceptance of the finished product.



#### 4.4.1 Shell, Coupling Ring and Nuts

The shell, coupling ring and nuts shall be made of aluminium alloy, dull low reflective electroless nickel plated, except plug with grounding option sizes 8, 10 and 12 for which the shell is gold plated (1.27µm min. over Ni underplate).

#### 4.4.2 Inserts

Bonded sandwich: Silicone/thermosetting or thermoplastic insert/silicone.

#### 4.4.3 Contacts

As specified in ESCC Detail Specification No. 3401/045.

#### 4.4.4 Contact Retaining Clip

The retaining clip shall be made of beryllium copper.

#### 4.4.5 Guiding and Locking Devices

Not applicable.

#### 4.4.6 Magnetism Level

Not applicable.

### 4.5 MARKING

#### 4.5.1 General

The marking of all components delivered to this specification shall be in accordance with the requirements of ESCC Basic Specification No. 21700 and the following paragraphs. Each component shall be marked in respect of:

- (a) Contact Identification.
- (b) The ESCC Component Number.
- (c) Characteristics.
- (d) Traceability information.

#### 4.5.2 Contact Identification

Contact identification shall be marked in accordance with Figure 2(b).

#### 4.5.3 The ESCC Component Number

The ESCC Component Number shall be constituted and marked as follows:

Example: 340104401B

- Detail Specification Number: 3401044
- Type Variant (Note 1): 01
- Testing Level: B

#### **NOTES:**

1. Marking of the type variant number is mandatory. No further reference to Type Variant is made in this specification.

#### 4.5.4 Characteristics

The characteristics to be marked in the following order of precedence are:

- (a) Shell Type.
- (b) Grounding.

- (c) Contact arrangement.
- (d) Type of contact.
- (e) Clocking position.
- (f) Contact information.

The information shall be constituted and marked as follows (example): 03 - 18-32 P A - L

- Shell Type: 03
- Grounding: -
- Contact arrangement: 18-32
- Type of contact: P
- Clocking position: A
- Contact information: L

**4.5.4.1 Shell Type**

The shell type shall be indicated by the numbers specified hereafter:

Code Number	Shell Type
03	Square flange receptacle back mounting
06	Plug
07	Single hole mounting receptacle

**4.5.4.2 Grounding**

Grounding shall be indicated by the letter 'G'. When grounding is not required, the letter 'G' shall be omitted and replaced by a dash (-). Grounding is only applicable to plugs.

**4.5.4.3 Contact Arrangements**

The number of contacts shall be as shown in Figure 2(b) and contact arrangements shall be indicated by the codes specified hereafter.

Code	Service Rating	Code	Service Rating
08-35	M	16-08	II
08-98	I	16-99	I
10-35	M	18-35	M
10-98	I	18-32	I
10-05	I	18-11	II
12-35	M	20-35	M
12-98	I	20-41	I
12-08	I	20-16	II
12-04	I	20-39	I
14-35	M	22-35	M
14-18	I	22-55	I
14-05	II	22-21	II
14-97	I	24-35	M
16-35	M	24-61	I
16-26	I	24-29	I
16-06	I	24-24	I

**4.5.4.4 Type of Contact**

The contact type shall be indicated by the following code letters.

Code Letter	Contact Type
P	Male
S	Female

#### 4.5.4.5 *Clocking Position*

Clocking positions are as shown in Figure 2(c) and shall be designated by the following code letters: A, B, C and D. Code letter N indicates the standard clocking position.

#### 4.5.4.6 *Contact Information*

L = connector ordered without contacts (without an L = connector delivered with contacts).

This information shall be marked on the packaging and is not marked on the connector.

Contacts shall be obtained from the same Manufacturer as supplied the connector in which they are to be mounted and this shall be verified before assembly.

#### 4.5.5 Traceability Information

Traceability information shall be marked in accordance with the requirements of ESCC Basic Specification No. 21700.

#### 4.5.6 Marking of Small Components

Where it is considered that a component is too small to accommodate the marking as specified above, as much as space permits shall be marked. The order of precedence shall be as specified in Para. 4.5.1. The marking information in full shall accompany each component in its primary package.

### 4.6 ELECTRICAL MEASUREMENTS

#### 4.6.1 Electrical Measurements at Room Temperature

The parameters to be measured in respect of electrical characteristics are scheduled in Table 2. Unless otherwise specified, these measurements shall be performed at  $T_{amb} = +22 \pm 3$  °C.

#### 4.6.2 Electrical Measurements at High and Low Temperatures (Table 3)

Not applicable.

#### 4.6.3 Circuit for Electrical Measurements (Figure 4)

Not applicable.

#### 4.7 BURN-IN AND ELECTRICAL MEASUREMENTS (TABLES 4 AND 5)

Not applicable.

**TABLE 2 – ELECTRICAL MEASUREMENTS AT ROOM TEMPERATURE**

No.	Characteristics	Symbol	Spec. and/or Test Method	Test Condition	Limits		Unit
					Min.	Max.	
1	Insulation Resistance	Ri	ESCC No. 3401 Para. 9.1.1.1	Para. 9.1.1.1	10000	-	MΩ
2	Voltage Proof Leakage Current Service Rating II Service Rating I Service Rating M	I <sub>L</sub>	ESCC No. 3401 Para. 9.1.1.2	2300Vrms 1800Vrms 1300Vrms		2	mA
3	Mated Shell Conductivity (1) (Voltage Drop)	Vd	ESCC No. 3401 Para. 9.1.1.4	Para. 9.1.1.4	-	1	mV

**NOTES:**

1. Applicable to mated connectors with grounding option.

**TABLES 3, 4 AND 5**

Not applicable.

4.8 ENVIRONMENTAL AND ENDURANCE TESTS

4.8.1 Measurements and Inspections on Completion of Environmental Tests

The parameters to be measured and inspections to be performed on completion of environmental testing shall be those specified in Table 6. Unless otherwise specified, these measurements shall be performed at T<sub>amb</sub> = +22±3 °C.

4.8.2 Measurements and Inspections at Intermediate Points during Endurance Tests

Not applicable.

4.8.3 Measurements and Inspections on Completion of Endurance Tests

The parameters to be measured and inspections to be performed on completion of endurance tests shall be those specified in Table 6. Unless otherwise specified, these measurements shall be performed at T<sub>amb</sub> = +22±3 °C.

4.8.4 Conditions for Operating Life Test (Part of Endurance Testing)

Not applicable.

4.8.5 Electrical Circuits for Operating Life Test

Not applicable.

4.8.6 Conditions for High Temperature Storage Test (Part of Endurance Testing)

The requirements for the high temperature storage test are specified in Section 9 of ESCC Generic Specification No. 3401. The conditions for high temperature storage testing shall be the maximum storage temperature specified in Table 1(b) of this specification.

**TABLE 6 – MEASUREMENTS AND INSPECTIONS ON COMPLETION OF ENVIRONMENTAL AND ENDURANCE TESTS**

No.	ESCC Generic No. 3401		Measurements and Inspections		Symbol	Limits		Unit
	Environmental and Endurance Tests (1)	Test Method and Conditions	Identification	Conditions		Min.	Max.	
01	Wiring	Para. 9.10	ESCC 3401/045			-	-	
02	Vibration	Para. 9.11 & Para. 4.2.4 of this spec.	<b>Initial Measurements</b> Coupling Screw(s) Unlocking Torque  <b>Final Measurements</b> Full Engagement Coupling Screw(s) Unlocking Torque Drift Visual Examination	-  - - - -	-  $\Delta$ - -	-  Not applicable  Not applicable  -   -	-  - -	%
03	Shock or Bump	Para. 9.12 & Para. 4.2.4 of this spec.	Full Engagement Visual Examination	- -	- -	- -	- -	
04	Climatic Sequence	Para. 9.13	<b>Dry Heat</b> Insulation Resistance  <b>Low Air Pressure</b> Voltage Proof Leakage Curr.  <b>Damp Heat</b> Insulation Resistance  <b>Final Measurements</b> External Visual Inspection  Insulation Resistance Voltage Proof Leakage Curr.	Table 2 Item 1  250Vrms  <b>Immediately after test</b> Table 2 Item 1  <b>After 1-24 hrs Recovery</b> ESCC 3401 Para. 9.7  Table 2 Item 1 Table 2 Item 2	Ri  I <sub>L</sub>  Ri  -  Ri I <sub>L</sub>	1000   -  Table 2 Item 2  100   -  ESCC 3401 Para. 9.7  Table 2 Item 1 Table 2 Item 2	M $\Omega$        M $\Omega$	
05	Seal Test	Para. 9.9	ESCC 3401 Para. 9.9			Not applicable		
06	Plating Thickness	Para. 9.14	Thickness			ESCC 3401/045		
07	Joint Strength	Para. 9.15	ESCC 3401 Para. 9.15			ESCC 3401 Para. 9.15		
08	Rapid Change of Temperature	Para. 9.16	Visual Examination Insulation Resistance Voltage Proof Leakage Curr.	- Table 2 Item 1 Table 2 Item 2	- Ri I <sub>L</sub>	-   - Table 2 Item 1 Table 2 Item 2	- - -	
09	Contact Retention (In Insert)	Para. 9.17 & Para. 4.3.4 of spec.	Contact Displacement	-	-	ESCC 3401 Para. 9.17		

No.	ESCC Generic No. 3401		Measurements and Inspections		Symbol	Limits		Unit
	Environmental and Endurance Tests (1)	Test Method and Conditions	Identification	Conditions		Min.	Max.	
10	Endurance	Para. 9.18	<b>Initial Measurements</b> Mating/Unmating Forces  Low Level Contact Resist. Mated Shell Conductivity  <b>Final Measurements</b> Visual Examination Mating/Unmating Forces  Low Level Contact Resistance Drift Mated Shell Conductivity Insulation Resistance Voltage Proof Leakage Curr.	-  ESCC 3401/045 Table 2 Item 3  - -  ESCC 3401/045  Table 2 Item 3 Table 2 Item 1 Table 2 Item 2	F  Rcl Vd  - F  ΔRcl  Vd Ri I <sub>L</sub>	Para. 4.3.5 of this spec. Record Values Table 2 Item 3  -   - Para. 4.3.5 of this spec. ESCC 3401/045  Table 2 Item 3 Table 2 Item 1 Table 2 Item 2		
11	Permanence of Marking	Para. 9.19	As applicable		-	-	-	
12	Mating/Unmating Forces	Para. 9.20	Force		F	Para. 4.3.5 of this spec.		
13	High Temperature Storage	Para. 9.21	<b>Initial Measurements</b> Low Level Contact Resist. Mated Shell Conductivity  <b>Final Measurements</b> Visual Examination Mating/Unmating Forces  Low Level Contact Resistance Drift Rated Current Contact Resistance Mated Shell Conductivity Insulation Resistance Voltage Proof Leakage Curr. Contact Retention (In Insert)	ESCC 3401/045 Table 2 Item 3  - -  ESCC 3401/045  ESCC 3401/045  Table 2 Item 3 Table 2 Item 1 Table 2 Item 2 Para. 4.3.4 of this spec.	Rcl Vd  - F  ΔRcl  Rcr  Vd Ri I <sub>L</sub> -	Record Values Table 2 Item 3  -   - Para. 4.3.5 of this spec. ESCC 3401/045  ESCC 3401/045  Table 2 Item 3 Table 2 Item 1 Table 2 Item 2 ESCC 3401 Para. 9.17		
14	Corrosion	Para. 9.22	Visual Examination	-	-	-	-	
15	Insert Retention (In Shell)	Para. 9.23 & Para. 4.3.6 of this spec.	Visual Examination	-	-	Para. 4.3.6 of this spec.		
16	Jackscrew Retention	Para. 9.24 & Para. 4.3.7 of this spec.	Visual Examination	-	-	Not applicable		
17	High Temperature Measurements	Para. 9.25	Insulation Resistance	Table 2 Item 1	Ri	500	-	MΩ
18	Overload Test	Para. 9.26	Internal Temperature Rated Current Contact Resistance Mated Shell Conductivity	ESCC 3401/045  Table 2 Item 3	T Rcr Vd	-   +100 ESCC 3401/045  Table 2 Item 3	°C	

No.	ESCC Generic No. 3401		Measurements and Inspections		Symbol	Limits		Unit
	Environmental and Endurance Tests (1)	Test Method and Conditions	Identification	Conditions		Min.	Max.	
			Insulation Resistance Voltage Proof Leakage Curr.	Table 2 Item 1 Table 2 Item 2	R <sub>i</sub> I <sub>L</sub>	Table 2 Item 1 Table 2 Item 2		
19	Maintenance Aging	Para. 9.27	Visual Examination Contact Retention Contact Insertion & Withdrawal Forces	- Para. 4.3.4 of this spec. Para. 4.3.8 of this spec.	-	-	-	ESCC 3401 Para. 9.17 Para. 4.3.8 of this spec.
20	Engage/Separation Forces	Para. 9.28 & Para. 4.3.9 of this spec.	Force		F	Para. 4.3.9 of this spec.		
21	Oversize Pin Exclusion	Para. 9.29 & Para. 4.3.10 of this spec.				ESCC 3401 Para. 9.29		
22	Probe Damage	Para. 9.30 & Para. 4.3.11 of this spec.	Contact Separation Force	Para. 4.3.9 of this spec.	F	Para. 4.3.9 of this spec.		
23	Solderability	Para. 9.31 & Para. 4.3.12 of this spec.				Para. 4.3.12 of this spec.		

**NOTES:**

1. The tests in this Table refer to either Chart IV or V and shall be used as applicable.