



**FLUOROPOLYMER INSULATED WIRES AND  
CABLES,**

**LOW FREQUENCY, 600V, -200 TO +200°C**

**BASED ON TYPE CSWL**

**ESCC Detail Specification No. 3901/024**

Issue 4	May 2013
---------	----------



**LEGAL DISCLAIMER AND COPYRIGHT**

European Space Agency, Copyright © 2013. All rights reserved.

The European Space Agency disclaims any liability or responsibility, to any person or entity, with respect to any loss or damage caused, or alleged to be caused, directly or indirectly by the use and application of this ESCC publication.

This publication, without prior permission of the European Space Agency and provided it is not used for a commercial purpose, may be:

- copied in whole, in any medium, without alteration or modification.
- copied in part, in any medium, provided that the ESCC document identification, comprising the ESCC symbol, document number and document issue, is removed.

**DOCUMENTATION CHANGE NOTICE**

(Refer to <https://escies.org> for ESCC DCR content)

DCR No.	CHANGE DESCRIPTION
750, 767	Specification upissued to incorporate editorial changes per DCR.

**TABLE OF CONTENTS**

1	GENERAL	6
1.1	SCOPE	6
1.2	TYPE VARIANTS	6
1.3	MAXIMUM RATINGS	6
1.4	PARAMETER DERATING INFORMATION	6
1.5	PHYSICAL CHARACTERISTICS	6
1.6	FUNCTIONAL DIAGRAM	6
2	APPLICABLE DOCUMENTS	6
3	TERMS, DEFINITIONS, ABBREVIATIONS, SYMBOLS AND UNITS	12
4	REQUIREMENTS	12
4.1	GENERAL	12
4.2	DEVIATIONS FROM GENERIC SPECIFICATION	12
4.2.1	Deviations from Special In-process Controls	12
4.2.2	Deviations from Final Production Tests (Chart II)	12
4.2.3	Deviations from Burn-in and Electrical Measurements (Chart III)	12
4.2.4	Deviations from Qualification Tests (Chart IV)	12
4.2.5	Deviations from Lot Acceptance Tests (Chart V)	12
4.3	MECHANICAL REQUIREMENTS	13
4.3.1	Dimension Check	13
4.3.2	Weight	13
4.4	MATERIALS AND FINISHES	14
4.4.1	Conductor	14
4.4.2	Insulation	14
4.4.3	Shield	14
4.4.4	Jacket	15
4.4.5	Construction of Multicore Cables	15
4.4.6	Colour Coding	15
4.5	MARKING	16
4.5.1	General	16
4.5.2	The ESCC Component Number	16
4.5.3	Characteristics	16
4.5.4	Traceability Information	16
4.5.5	Additional Marking	16
4.6	ELECTRICAL MEASUREMENTS	16
4.6.1	Electrical Measurements at Room Temperature	16

4.6.2	Electrical Measurements at High and Low Temperatures	16
4.6.3	Circuits for Electrical Measurements	16
4.7	BURN-IN TESTS	17
4.8	ENVIRONMENTAL AND ENDURANCE TESTS	17
4.8.1	Mechanical Properties of Conductor	17
4.8.2	Accelerated Ageing	17
4.8.3	Wrap Test at Ambient Temperature	17
4.8.4	Voltage Test	18
4.8.5	Shrinkage	18
4.8.6	Blocking	18
4.8.7	Cold Bend Test	19
4.8.8	Cut-through Resistance	19
4.8.9	Notch Resistance	19
4.8.10	Resistance to Fluids	19
4.8.11	Surface Resistance	19
4.8.12	Abrasion Resistance	19
4.8.13	Soldering	19
4.8.14	Solderability	19
4.8.15	Radiation Resistance	19
4.8.16	Overload Resistance	19
4.8.17	Long-term Ageing Test	20
4.8.18	Anthony and Brown Test	20
APPENDIX A		21
APPENDIX B		21

## 1 GENERAL

### 1.1 SCOPE

This specification details the ratings, physical and electrical characteristics, test and inspection data for Fluoropolymer Insulated Wires and Cables, Low Frequency, 600V, -200 to +200 °C, Based on Type CSWL.

It shall be read in conjunction with ESCC Generic Specification No. 3901, the requirements of which are supplemented herein.

### 1.2 TYPE VARIANTS

Variants of the basic types of wires and cables specified herein, which are also covered by this specification, are listed in Table 1(a).

### 1.3 MAXIMUM RATINGS

The maximum ratings, applicable to the finished wires and cables specified herein, which shall not be exceeded at any time during use or storage in controlled space environment, are scheduled in Table 1(b).

### 1.4 PARAMETER DERATING INFORMATION

The derating information applicable to the finished wires and cables specified herein is as follows:

- The maximum current for each wire used in a bundle shall be:

$$I_{Bmax} = I_{max} \times \frac{29 - n}{28} \quad (\text{for } 1 < n < 15)$$
$$I_{Bmax} = \frac{I_{max}}{2} \quad (\text{for } n > 15)$$

where n = number of wires in the bundle.

- The temperature derating information is shown in Figure 1 with maximum current  $I_{max}$  for a single wire.
- The derating factors contained herein indicate maximum stress values and do not preclude further derating.

### 1.5 PHYSICAL CHARACTERISTICS

The physical characteristics of the finished wires and cables specified herein are shown in Figure 2.

### 1.6 FUNCTIONAL DIAGRAM

Not applicable.

## 2 APPLICABLE DOCUMENTS

The following documents form part of this specification and shall be read in conjunction with it:

- ESCC Generic Specification No. 3901, Wires and Cables, Electrical, 600V, Low Frequency.
- ISO 2635, Conductors for General Purpose Aircraft Electrical Cables and Aerospace Applications - Dimensions and Characteristics. The issue which is in effect at the time of order placement shall apply.



**TABLE 1(a) – TYPE VARIANTS**

Variant No.	Shielded		No. of Cores	Wire Size ISO/AWG (Note 1)	Stranding No. of Strands x Diameter (mm)	Conductor Characteristics			Shield Strand Ø (mm)	Core Max Ø (mm)	Finished Wire Or Cable Characteristics	
	Yes	No				Max Ø (mm)	Nom Section (mm <sup>2</sup> )	Max Ohmic Resistance (Ω/km)			Max Ø (mm)	Max Weight (kg/km)
01	-	x	1	-/30	7x0.102	0.32	0.057	375	-	-	0.75	1.3
02	-	x	1	-/28	7x0.127	0.39	0.09	253	-	-	0.85	1.7
03	-	x	1	001/26	19x0.1	0.47	0.15	157	-	-	1	2.2
04	-	x	1	002/24	19x0.12	0.58	0.25	111	-	-	1.15	3.1
05	-	x	1	004/22	19x0.15	0.76	0.4	58	-	-	1.3	4.4
06	-	x	1	006/20	19x0.2	0.99	0.6	32	-	-	1.55	7.4
07	-	x	1	012/16	19x0.3	1.49	1.2	14	-	-	2.2	17
08	-	x	1	030/12	37x0.32	2.18	3	7	-	-	3	33
09	-	x	2	-/30	7x0.102	0.32	0.057	383	-	0.75	1.5	2.7
10	-	x	2	-/28	7x0.127	0.39	0.09	258	-	0.85	1.7	3.5
11	-	x	2	001/26	19x0.1	0.47	0.15	170	-	1	2	4.6
12	-	x	2	002/24	19x0.12	0.58	0.25	120	-	1.15	2.3	6.5
13	-	x	2	004/22	19x0.15	0.76	0.4	63	-	1.3	2.6	9.2
14	-	x	2	006/20	19x0.2	0.99	0.6	35	-	1.55	3.1	15.5
15	-	x	2	012/16	19x0.3	1.49	1.2	15	-	2.2	4.4	35.7
16	-	x	2	030/12	37x0.32	2.18	3	7.5	-	3	6	69.3
17	-	x	3	-/30	7x0.102	0.32	0.057	384	-	0.75	1.6	4.1
18	-	x	3	-/28	7x0.127	0.39	0.09	259	-	0.85	1.8	5.3
19	-	x	3	001/26	19x0.1	0.47	0.15	171	-	1	2.2	6.9
20	-	x	3	002/24	19x0.12	0.58	0.25	121	-	1.15	2.5	9.8
21	-	x	3	004/22	19x0.15	0.76	0.4	64	-	1.3	2.8	13.9
22	-	x	3	006/20	19x0.2	0.99	0.6	37	-	1.55	3.3	23.3
23	-	x	3	012/16	19x0.3	1.49	1.2	15	-	2.2	4.7	53.6



Variant No.	Shielded		No. of Cores	Wire Size ISO/AWG (Note 1)	Stranding No. of Strands x Diameter (mm)	Conductor Characteristics			Shield Strand Ø (mm)	Core Max Ø (mm)	Finished Wire Or Cable Characteristics	
	Yes	No				Max Ø (mm)	Nom Section (mm <sup>2</sup> )	Max Ohmic Resistance (Ω/km)			Max Ø (mm)	Max Weight (kg/km)
24	-	x	3	030/12	37x0.32	2.18	3	7.5	-	3	6.5	104
25	-	x	4	-/30	7x0.102	0.32	0.057	385	-	0.75	1.8	5.4
26	-	x	4	-/28	7x0.127	0.39	0.09	260	-	0.85	2	7.1
27	-	x	4	001/26	19x0.1	0.47	0.15	171	-	1	2.4	9.2
28	-	x	4	002/24	19x0.12	0.58	0.25	122	-	1.15	2.8	13
29	-	x	4	004/22	19x0.15	0.76	0.4	64	-	1.3	3.1	18.5
30	-	x	4	006/20	19x0.2	0.99	0.6	37	-	1.55	3.7	31.1
31	-	x	4	012/16	19x0.3	1.49	1.2	16	-	2.2	5.3	71.4
32	-	x	4	030/12	37x0.32	2.18	3	7.9	-	3	7.2	138.6
33	x	-	1	-/30	7x0.102	0.32	0.057	383	0.079	0.75	1.35	4.3
34	x	-	1	-/28	7x0.127	0.39	0.09	258	0.079	0.85	1.45	5
35	x	-	1	001/26	19x0.1	0.47	0.15	170	0.079	1	1.6	6
36	x	-	1	002/24	19x0.12	0.58	0.25	120	0.079	1.15	1.75	7.3
37	x	-	1	004/22	19x0.15	0.76	0.4	63	0.079	1.3	1.9	9.1
38	x	-	1	006/20	19x0.2	0.99	0.6	35	0.079	1.55	2.15	12.8
39	x	-	1	012/16	19x0.3	1.49	1.2	15	0.079	2.2	2.8	24
40	x	-	1	030/12	37x0.32	2.18	3	7.5	0.079	3	3.6	42.8
41	x	-	2	-/30	7x0.102	0.32	0.057	383	0.079	0.75	2.1	7.3
42	x	-	2	-/28	7x0.127	0.39	0.09	258	0.079	0.85	2.3	8.5
43	x	-	2	001/26	19x0.1	0.47	0.15	170	0.079	1	2.6	10
44	x	-	2	002/24	19x0.12	0.58	0.25	120	0.079	1.15	2.9	12.5
45	x	-	2	004/22	19x0.15	0.76	0.4	63	0.079	1.3	3.2	16
46	x	-	2	006/20	19x0.2	0.99	0.6	35	0.079	1.55	3.7	24.2
47	x	-	2	012/16	19x0.3	1.49	1.2	15	0.079	2.2	5	44.5
48	x	-	2	030/12	37x0.32	2.18	3	7.5	0.079	3	6.6	81





Variant No.	Shielded		No. of Cores	Wire Size ISO/AWG (Note 1)	Stranding No. of Strands x Diameter (mm)	Conductor Characteristics			Shield Strand Ø (mm)	Core Max Ø (mm)	Finished Wire Or Cable Characteristics	
	Yes	No				Max Ø (mm)	Nom Section (mm <sup>2</sup> )	Max Ohmic Resistance (Ω/km)			Max Ø (mm)	Max Weight (kg/km)
49	x	-	3	-/30	7x0.102	0.32	0.057	385	0.079	0.75	2.2	9
50	x	-	3	-/28	7x0.127	0.39	0.09	259	0.079	0.85	2.4	10.6
51	x	-	3	001/26	19x0.1	0.47	0.15	171	0.079	1	2.8	12.7
52	x	-	3	002/24	19x0.12	0.58	0.25	121	0.079	1.15	3.1	15.9
53	x	-	3	004/22	19x0.15	0.76	0.4	64	0.079	1.3	3.4	24.3
54	x	-	3	006/20	19x0.2	0.99	0.6	37	0.079	1.55	3.9	33
55	x	-	3	012/16	19x0.3	1.49	1.2	15	0.079	2.2	5.3	62.2
56	x	-	3	030/12	37x0.32	2.18	3	7.5	0.079	3	7	115.5
57	x	-	4	-/30	7x0.102	0.32	0.057	386	0.079	0.75	2.4	10.9
58	x	-	4	-/28	7x0.127	0.39	0.09	260	0.079	0.85	2.6	13
59	x	-	4	001/26	19x0.1	0.47	0.15	171	0.079	1	3	15.7
60	x	-	4	002/24	19x0.12	0.58	0.25	122	0.079	1.15	3.4	20.2
61	x	-	4	004/22	19x0.15	0.76	0.4	64	0.079	1.3	3.7	26.4
62	x	-	4	006/20	19x0.2	0.99	0.6	37	0.079	1.55	4.3	42
63	x	-	4	012/16	19x0.3	1.49	1.2	16	0.079	2.2	5.9	80.7
64	x	-	4	030/12	37x0.32	2.18	3	7.9	0.079	3	7.8	151.5

**NOTES:**

1. Where given, in accordance with ISO 2635. AWG sizes are for reference only when ISO sizes are shown.

**TABLE 1(b) – MAXIMUM RATINGS**

No.	Characteristics	Symbol	Maximum Rating	Unit	Remarks
1	Voltage	$V_p$	600	$V_{rms}$	
2	Maximum Current (Note 1)	$I_{max}$	1.3 1.5 2.5 3.5 5 7.5 13 23	A	For AWG: 30 28 26 24 22 20 16 12
3	Operating Temperature Range	$T_{amb}$	-200 to +200	°C	
4	Storage Temperature Range	$T_{stg}$	-200 to +200	°C	

**NOTES:**

- The above specified current will generate a temperature rise of approximately 50°C above ambient temperature in a vacuum environment. Precautions shall be taken to prevent the total temperature of the wire (ambient plus rise) exceeding the continuous operating temperature of the wire.

**FIGURE 1 – PARAMETER DERATING INFORMATION**

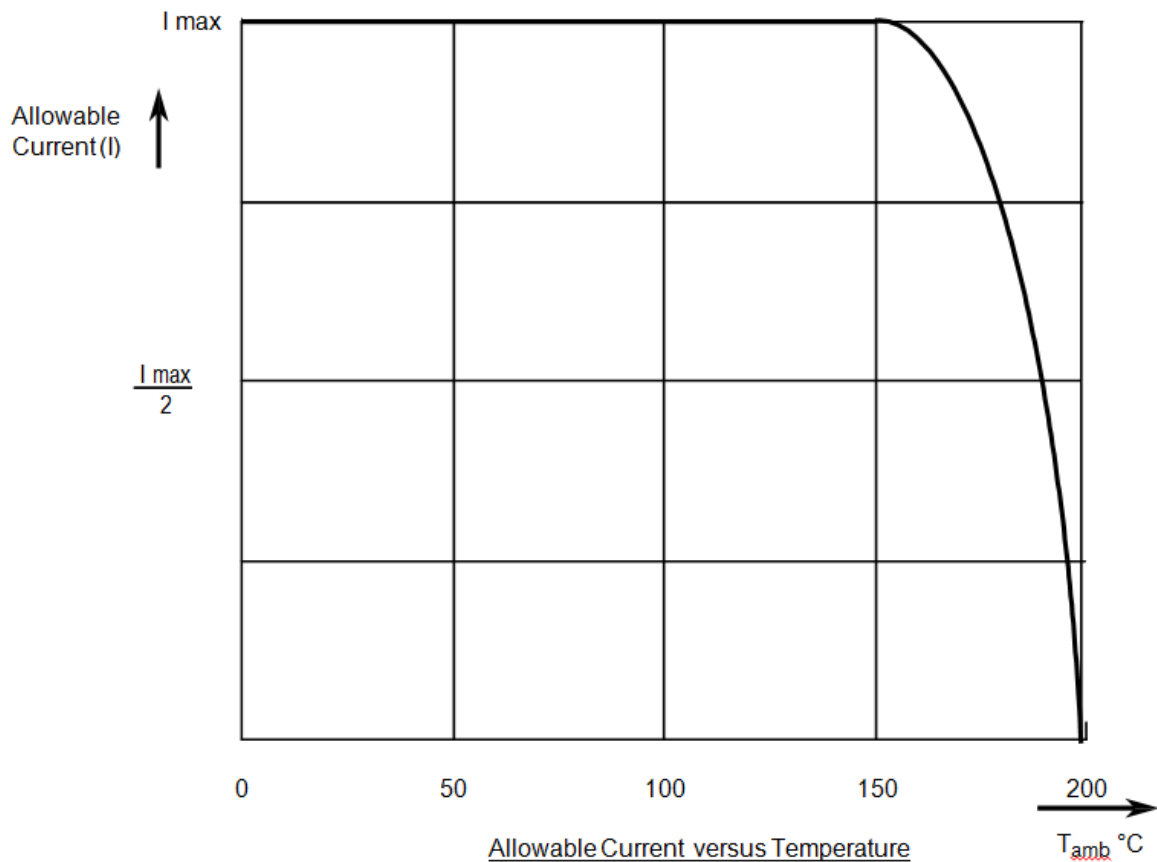

**FIGURE 2 – PHYSICAL CHARACTERISTICS**

Dimensions are given in Table 1(a)

**FIGURE 2(a) – FINISHED WIRES**

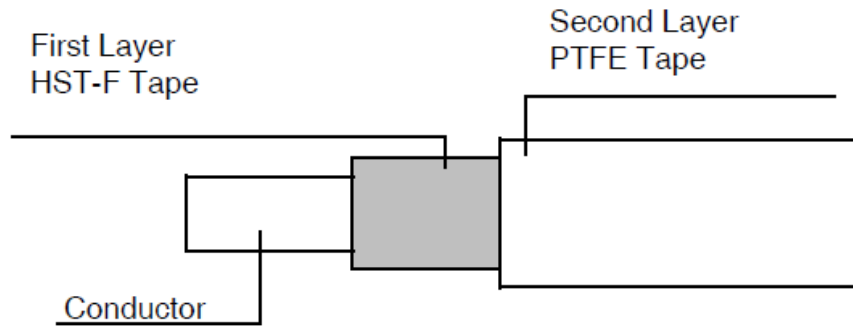

**FIGURE 2(b) – MULTICORE CABLE**

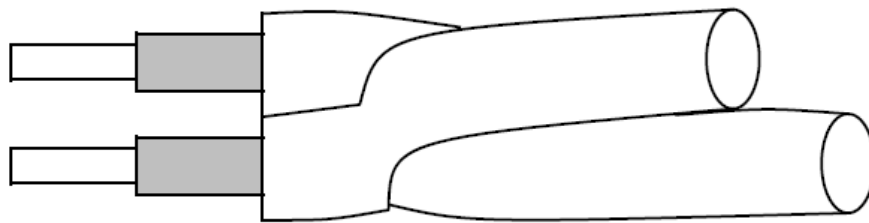

**NOTES:**

1. Finished wire according to Figure 2(a).

**FIGURE 2(c) – SHIELDED AND JACKETED CABLES**

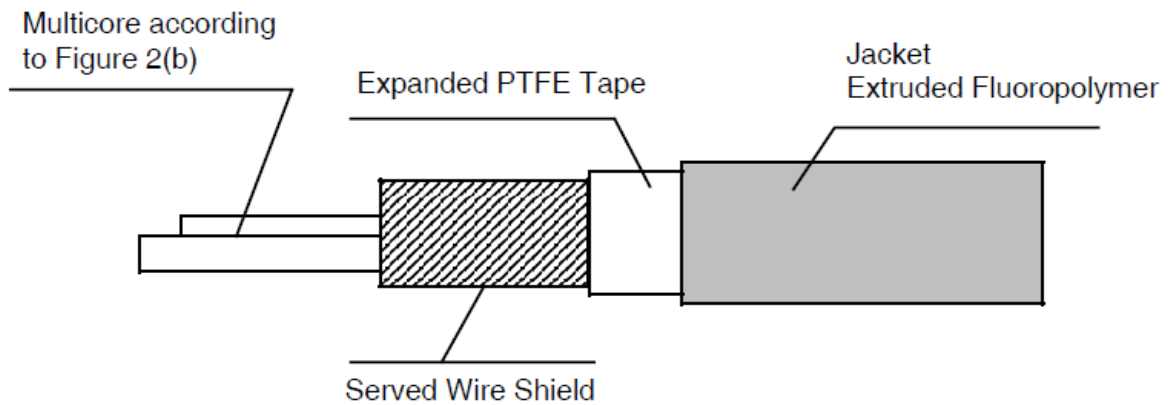

### 3 **TERMS, DEFINITIONS, ABBREVIATIONS, SYMBOLS AND UNITS**

For the purpose of this specification, the terms, definitions, abbreviations, symbols and units specified in ESCC Basic Specification No. 21300 and ESCC Generic Specification No. 3901 shall apply.

### 4 **REQUIREMENTS**

#### 4.1 **GENERAL**

The complete requirements for procurement of the finished wires and cables specified herein are stated in this specification and ESCC Generic Specification No. 3901. Deviations from the Generic Specification, applicable to this specification only, are listed in Para. 4.2.

Deviations from the applicable Generic Specification and this Detail Specification, formally agreed with specific Manufacturers on the basis that the alternative requirements are equivalent to the ESCC requirements and do not affect the components' reliability, are listed in the Appendices attached to this specification.

#### 4.2 **DEVIATIONS FROM GENERIC SPECIFICATION**

##### 4.2.1 **Deviations from Special In-process Controls**

None.

##### 4.2.2 **Deviations from Final Production Tests (Chart II)**

None.

##### 4.2.3 **Deviations from Burn-in and Electrical Measurements (Chart III)**

Not applicable.

##### 4.2.4 **Deviations from Qualification Tests (Chart IV)**

None.

##### 4.2.5 **Deviations from Lot Acceptance Tests (Chart V)**

None.

4.3 MECHANICAL REQUIREMENTS

4.3.1 Dimension Check

The dimensions of the finished wires and cables specified herein shall be checked. They shall conform to those shown in Table 1(a), Figure 2 and Para 4.4 of this specification (see below for the list of parameters to be checked).

**LIST OF PARAMETERS TO BE CHECKED**

Parameter	Table 1(a)	Figure 2	Para. 4.4
<b><u>COMPOSITION</u></b>			
Number of conductors	X		
Gauge	X		
Shielding	X		
Jacket		X	
<b><u>CONDUCTOR</u></b>			
Nature			X
Outer diameter	X		
Number of strands	X		
Strand diameter	X		
Length of lay			X
Silver thickness			X
<b><u>INSULATION</u></b>			
Composition		X	X
Outer diameter	X		
<b><u>SHIELDING</u></b>			
Number of strands	X		
Type of shielding			X
Strand diameter	X		
Nature		X	X
Silver thickness			X
Shielding lay			X
Shield coverage			X
<b><u>JACKET</u></b>			
Composition		X	X
Protective tape wraps		X	X
Outer diameter	X		

4.3.2 Weight

The maximum weight of the finished wires and cables specified herein shall be as specified in Table 1(a).

#### 4.4 MATERIALS AND FINISHES

The materials and finishes shall be as specified herein. Where a definite material is not specified, a material which will enable the wires and cables specified herein to meet the performance requirements of this specification shall be used. Acceptance or approval of any constituent material does not guarantee acceptance of the finished product.

##### 4.4.1 Conductor

###### 4.4.1.1 *Material Characteristics*

All strands used in the manufacture of the conductors shall be silver-coated, soft or annealed, oxygen-free high conductivity copper for ISO 004, 006, 012 and 030 and silver-coated high strength copper alloy for ISO 001, 002 and AWG 28 and 30.

The silver thickness shall be 2 microns minimum.

For all copper conductors, any strand shall show a 10% minimum elongation.

For high-strength copper alloy conductors, the tensile characteristics shall be not less than 6% in elongation and 35kg per square mm in tensile strength.

For determination of the conductor resistance at +20°C, as mentioned in Para 9.5 of ESCC Generic Specification No. 3901, the  $\alpha$  coefficient for copper alloy is 0.0035.

###### 4.4.1.2 *Stranding*

The conductors shall be constructed of concentrically laid strands to produce a smooth and uniform conductor of circular cross-section and free from any high strands or other surface irregularities.

The length of lay of the external layer shall not be less than 8, nor more than 16, times the maximum conductor diameter specified in Table 1(a).

##### 4.4.2 Insulation

###### 4.4.2.1 *Material*

Any insulating material shall be virgin high strength toughened fluoropolymer PTFE tape (HST-F) and PTFE with only those additives that are necessary for processing and pigmentation.

###### 4.4.2.2 *Construction*

The insulation shall have a uniform cross-section throughout the length of the wire and the conductor shall be evenly centred in the insulation.

The insulation shall consist of one wrapped lay of high strength toughened fluoropolymer PTFE tape (HST-F) and one lay of PTFE tape (min. 51% overlap, wall thickness 0.15 mm nom.) as specified in Figure 2(a).

##### 4.4.3 Shield

###### 4.4.3.1 *Material Characteristics*

Shield strands shall meet the requirements for silver-coated annealed copper outlined in Para. 4.4.1.1 of this specification.

4.4.3.2 *Construction*

The shield shall be closely and helically wound around the single insulated wire or twisted bundle of insulated wires (core) and provide not less than 90% coverage as calculated by the following formula:

$$K = \frac{n \times d_w \sqrt{(\pi D)^2 + P^2}}{P \pi D} \times 100(\%)$$

- K = Coverage (%)
- n = Number of serving wires.
- d<sub>w</sub> = Shield strand diameter (mm).
- D = Diameter of core (mm).
- P = Serving Pitch (mm).

4.4.4 Jacket

All shielded cables shall be provided with jackets of wrapped expanded, microporous polyterafluoroethylene tapes and an extruded fluoropolymer (wall thickness 0.2 mm nominal) as specified in Figure 2(c).

4.4.5 Construction of Multicore Cables

Multicore cables shall be constructed by twisting the required number and size of finished wires to form a uniform cable without high strands, bends or other irregularities. Finished wires of only one size shall be used for one cable. The cabling shall be with a left-hand lay and the lay length shall not be less than 12 times and not be more than 16 times the outside diameter of the unshielded unjacketed cable. The construction of shielded and jacketed cables is shown in Figure 2(c).

4.4.6 Colour Coding

4.4.6.1 *Finished Wire Colour Coding*

The colour of the finished wires shall be the red except when colouring is specifically required in the contract.

Colours:

- Black, brown, red, orange, yellow, green, blue, violet, grey, white.

4.4.6.2 *Multicore Cable Colour Coding*

If the contract does not define any specific colour-coding, all individual cores in multicore cables shall be coloured according to the following scheme.

No. of Cores In Cable	Colour of Respective Cores			
2	red	blue		
3	red	blue	yellow	
4	red	blue	yellow	green

4.4.6.3 *Jacket Colour*

The colour of jackets shall be white.

## 4.5 MARKING

### 4.5.1 General

The marking of all spools of finished wires and cables delivered to this specification shall be in accordance with the requirements of ESCC Basic Specification No. 21700. Each spool shall be marked in respect of:

- (a) The ESCC Component Number.
- (b) Characteristics.
- (c) Traceability Information.
- (d) Additional Marking.

### 4.5.2 The ESCC Component Number

Each spool shall bear the ESCC Component Number which shall be constituted and marked as follows:

Example: 390102401B

- Detail Specification Number: 3901024
- Type Variant (see Table 1(a)): 01
- Testing Level (B is mandatory): B

### 4.5.3 Characteristics

The characteristics shall show the length(s) of finished wire or cable wound on each spool and shall be marked as follows:

Example: 100m

- Length in metres (see Note): 100
- Symbol for metres: m

#### **NOTES:**

1. Whenever the length is less than 100 metres, insert a zero in the first block (example: 075m). If more than one length of finished wire or cable is wound on a spool, the characteristics of each length shall be marked as above.

### 4.5.4 Traceability Information

Each spool shall be marked in respect of traceability information in accordance with the requirements of ESCC Basic Specification No. 21700.

### 4.5.5 Additional Marking

Each spool shall bear the Manufacturer's Quality Control Inspector's stamp.

## 4.6 ELECTRICAL MEASUREMENTS

### 4.6.1 Electrical Measurements at Room Temperature

The parameters to be measured at room temperature are scheduled in Table 2. The measurements shall be performed at  $T_{amb} = +22 \pm 3$  °C.

### 4.6.2 Electrical Measurements at High and Low Temperatures

Not applicable.

### 4.6.3 Circuits for Electrical Measurements

Not applicable.



**4.7 BURN-IN TESTS**

Not applicable.

**4.8 ENVIRONMENTAL AND ENDURANCE TESTS****4.8.1 Mechanical Properties of Conductor**

As detailed in Para. 4.4.1.1 of this specification.

**4.8.2 Accelerated Ageing**

Ageing Temperature: +230±5 °C.

**4.8.3 Wrap Test at Ambient Temperature**

The mandrel diameters and applied loads for wrap testing of finished wires are given in Table A.  
The mandrel diameters and applied loads for shielded and jacketed cables are given in Table B.

**TABLE A – MANDREL DIAMETERS AND LOADS FOR FINISHED WIRES**

Wire Size ISO/AWG	Mandrel Diameter (mm)	Applied Weight (kg)
-/30	5	0.15
-/28	6	0.25
001/26	6	0.25
002/24	6	0.25
004/22	6	0.4
006/20	6	0.4
012/16	10	0.5
030/12	20	1

**TABLE B – MANDREL DIAMETERS AND LOADS FOR SHIELDED AND JACKETED CABLES**

Cable Size ISO/AWG	Number of Cores	Mandrel Diameter (mm)	Applied Weight (kg)
-/30	1	8	0.15
-/28	1	8	0.25
001/26	1	10	0.25
002/24	1	12	0.25
004/22	1	15	0.5
006/20	1	15	0.5
012/16	1	20	1
030/12	1	20	1
-/30	2	10	0.25
-/28	2	10	0.5
001/26	2	15	0.5
002/24	2	15	0.5
004/22	2	20	0.8
006/20	2	20	0.8
012/16	2	25	1
030/12	2	30	1
-/30	3	12	0.25
-/28	3	12	0.5
001/26	3	15	0.75
002/24	3	15	0.75
004/22	3	20	1.2
006/20	3	20	1.2
012/16	3	30	1.5
030/12	3	40	1.5
-/30	4	15	0.5
-/28	4	15	0.8
001/26	4	15	1
002/24	4	20	1
004/22	4	20	1.5
006/20	4	25	1.5
012/16	4	30	1.5
030/12	4	40	1.5

4.8.4 Voltage Test

No particular conditions are applicable.

4.8.5 Shrinkage

The shrinkage temperature shall be +200±5 °C.

4.8.6 Blocking

The blocking temperature shall be +230±5 °C.

4.8.7 Cold Bend Test

The mandrel diameters and loads shall be as specified in Table C.

**TABLE C – MANDREL DIAMETERS AND LOADS FOR FINISHED WIRES OR CORES**

Wire Size ISO/AWG	Mandrel Diameter (mm)	Applied Weight (kg)
-/30	5	0.15
-/28	6	0.25
001/26	6	0.25
002/24	6	0.25
004/22	6	0.4
006/20	6	0.4
012/16	10	0.5
030/12	20	1

4.8.8 Cut-through Resistance

The mean load measured during 9 tests shall not be less than the relevant value specified below:

Wire Size	ISO	-	-	001	002	004	006	012	030
	AWG	30	28	26	24	22	20	16	12
Cut-through Load (kg)		3	3.5	3.5	3.5	6	7	8	8

4.8.9 Notch Resistance

The depth of notch shall be 0.04mm.

4.8.10 Resistance to Fluids

No particular conditions are applicable.

4.8.11 Surface Resistance

No particular conditions are applicable.

4.8.12 Abrasion Resistance

The weight to be applied to the needle is specified below:

Wire Size	ISO	-	-	001	002	004	006	012	030
	AWG	30	28	26	24	22	20	16	12
Scrape Abrasion (load in grammes)		380	450	480	550	600	600	700	850

4.8.13 Soldering

No particular conditions are applicable.

4.8.14 Solderability

No particular conditions are applicable.

4.8.15 Radiation Resistance

No particular conditions are applicable.

4.8.16 Overload Resistance

No particular conditions are applicable.

**4.8.17 Long-term Ageing Test**

The long-term ageing temperature shall be +200°C.

**4.8.18 Anthony and Brown Test**

No particular conditions are applicable.

**TABLE 2 – ELECTRICAL MEASUREMENTS AT ROOM TEMPERATURE**

No.	Characteristics	Specification and Test Method	Test Condition	Limits	Unit
1	Conductor Resistance	ESCC No. 3901, Section 9	Para. 9.5	Table 1(a)	Ω/km
2	Spark Test	ESCC No. 3901, Section 9	Para. 9.6	Insulation: 3 Jacket: 1.5	kV
3	Voltage Test	ESCC No. 3901, Section 9	Para. 9.7	Para. 9.7	kV
4	Insulation Resistance	ESCC No. 3901, Section 9	Para. 9.8	Insulation: 750 Jacket: 30	MΩ.km
5	Surface Resistance	ESCC No. 3901, Section 9	Para. 9.22	125	MΩ.mm

**APPENDIX A**

Appendix A is no longer applicable.

**APPENDIX B****AGREED DEVIATIONS FOR AXON' CABLE SAS (F)**

Items Affected	Description of Deviations
Figure 2	Expanded PTFE tape shall be CELLOFLON®
Para. 4.4.4	Expanded PTFE tape shall be CELLOFLON®

**NOTES:**

1. CELLOFLON is a Registered Trade Mark of AXON' CABLE SAS.