



**CAPACITORS, LEADLESS SURFACE MOUNTED,
TANTALUM, SOLID ELECTROLYTE,
LOW EQUIVALENT SERIES RESISTANCE**

BASED ON TYPE TES

ESCC Detail Specification No. 3012/004

Issue 2	November 2013
---------	---------------



LEGAL DISCLAIMER AND COPYRIGHT

European Space Agency, Copyright © 2013. All rights reserved.

The European Space Agency disclaims any liability or responsibility, to any person or entity, with respect to any loss or damage caused, or alleged to be caused, directly or indirectly by the use and application of this ESCC publication.

This publication, without the prior permission of the European Space Agency and provided that it is not used for a commercial purpose, may be:

- copied in whole, in any medium, without alteration or modification.
- copied in part, in any medium, provided that the ESCC document identification, comprising the ESCC symbol, document number and document issue, is removed.

DOCUMENTATION CHANGE NOTICE

(Refer to <https://escies.org> for ESCC DCR content)

DCR No.	CHANGE DESCRIPTION
810	Specification upissued to incorporate changes per DCR. The specification has been converted into MSWord. Changes in presentation are possible.

TABLE OF CONTENTS

1	GENERAL	6
1.1	SCOPE	6
1.2	COMPONENT TYPE VARIANTS AND RANGE OF COMPONENTS	6
1.3	MAXIMUM RATINGS	6
1.4	PARAMETER DERATING INFORMATION	6
1.5	PHYSICAL DIMENSIONS	6
1.6	FUNCTIONAL DIAGRAM	6
2	APPLICABLE DOCUMENTS	6
3	TERMS, DEFINITIONS, ABBREVIATIONS, SYMBOLS AND UNITS	6
4	REQUIREMENTS	12
4.1	GENERAL	12
4.2	DEVIATIONS FROM GENERIC SPECIFICATION	12
4.2.1	Deviations from Special In-Process Controls	12
4.2.2	Deviations from Final Production Tests (Chart II)	12
4.2.3	Deviations from Burn-in and Electrical Measurements (Chart III)	12
4.2.4	Deviations from Qualification Tests (Chart IV)	12
4.2.5	Deviations from Lot Acceptance Tests (Chart V)	12
4.3	MECHANICAL REQUIREMENTS	12
4.3.1	Dimension Check	12
4.3.2	Weight	12
4.4	MATERIALS AND FINISHES	12
4.4.1	Terminal Material and Finish	12
4.5	MARKING	13
4.5.1	General	13
4.5.2	The ESCC Component Number	13
4.5.3	Electrical Characteristics and Ratings	13
4.5.3.1	Polarity	13
4.5.3.2	Capacitance Value	14
4.5.3.3	Tolerance	14
4.5.3.4	Rated Voltage	14
4.5.3.5	Equivalent Series Resistance	14
4.5.4	Traceability Information	14
4.6	ELECTRICAL MEASUREMENTS	15
4.6.1	Electrical Measurements at Room Temperature	15
4.6.2	Electrical Measurements at High and Low Temperatures	15
4.6.3	Circuits for Electrical Measurements (Figure 4)	15

4.7	BURN-IN TESTS	15
4.7.1	Parameter Drift Values	15
4.7.2	Conditions for Burn-in	15
4.7.3	Electrical Circuit for Burn-in (Figure 5)	15
4.8	ENVIRONMENTAL AND ENDURANCE TESTS (CHARTS IV AND V OF ESCC GENERIC SPECIFICATION NO. 3012)	17
4.8.1	Measurements and Inspections on Completion of Environmental Tests	17
4.8.2	Measurements and Inspections at Intermediate Points During Endurance Tests	17
4.8.3	Measurements and Inspections on Completion of Endurance Tests	17
4.8.4	Conditions for Operating Life (Part of Endurance Testing)	17
4.8.5	Electrical Circuit for Operating Life Tests (Figure 5)	17
	APPENDIX 'A'	21

1 GENERAL

1.1 SCOPE

This specification details the ratings, physical and electrical characteristics, test and inspection data for Capacitors, Leadless Surface Mounted, Tantalum, Solid Electrolyte, Low Equivalent Series Resistance, based on Type TES. It shall be read in conjunction with ESCC Generic Specification No. 3012, the requirements of which are supplemented herein.

1.2 COMPONENT TYPE VARIANTS AND RANGE OF COMPONENTS

The variants and the range of components covered by this specification are given in Table 1(a).

1.3 MAXIMUM RATINGS

The maximum ratings, which shall not be exceeded at any time during use or storage, applicable to the components specified herein, are as scheduled in Table 1(b).

1.4 PARAMETER DERATING INFORMATION

The parameter derating information applicable to the capacitors specified herein is shown in Figure 1.

1.5 PHYSICAL DIMENSIONS

The physical dimensions of the capacitors specified herein are shown in Figure 2.

1.6 FUNCTIONAL DIAGRAM

The functional diagram for the capacitors specified herein is shown in Figure 3.

2 APPLICABLE DOCUMENTS

The following documents form part of this specification and shall be read in conjunction with it:

- (a) ESCC Generic Specification No. 3012 for Capacitors, Leadless Surface Mounted, Tantalum, Solid Electrolyte, Enclosed Anode Connection

3 TERMS, DEFINITIONS, ABBREVIATIONS, SYMBOLS AND UNITS

For the purpose of this specification, the terms, definitions, abbreviations, symbols and units specified in ESCC Basic specification No. 21300 shall apply.

TABLE 1(a) - TYPE VARIANTS AND RANGE OF COMPONENTS

Variant Number	Case Code (Style) (Note 1)	Capacitance Range C_n (μ F) (Notes 2, 3)	Rated Voltage U_R (V) (Note 2)	Maximum Equivalent Series Resistance ESR (m Ω) (Note 2)	Terminal Material and Finish	Weight Max (g)
01	A (1206)	1 to 22	6.3 to 25	900 to 3000	G16	0.1
02	B (1210)	1 to 47	6.3 to 50	500 to 2000	G16	0.2
03	C (2312)	3.3 to 150	6.3 to 50	300 to 1000	G16	0.3
04	D (2917)	4.7 to 330	6.3 to 50	35 to 200	P17	0.5
05	E (2917)	33 to 470	6.3 to 35	30 to 65	P17	0.7

NOTES:

- See Figure 2.
- The following rated Capacitance (C_n), maximum Rated Voltage (U_R) and maximum Equivalent Series Resistance values (ESR) are available related to the Case Code (letters indicate Case Code; numbers indicate maximum ESR in m Ω):

Capacitance C_n (μ F)	Rated Voltage U_R							
	6.3V	10V	12V	16V	20V	25V	35V	50V
1						A 3000		B 2000
3.3					A 2500		B 1000	C 1000
4.7				A 2000		B 1000	C 600	D 200
10		A 1800			B 1000	C 600	D 120	
22	A 900			B 600	C 400		D 100	
33		B 650			C 300	D 65	E 65	
47	B 500			C 350	D 55	E 65		
100		C 200		D 55	E 45			
150	C 300	D 45		E 40				
220		D 35	E 35					
330	D 35	E 35						
470	E 30							

- The following Capacitance Tolerances are available:
 $\pm 10\%$ (K)
 $\pm 20\%$ (M)

TABLE 1(b) - MAXIMUM RATINGS

No.	Characteristics	Symbols	Maximum Ratings		Units	Remarks
1	Rated Voltage	U_R	See Table 1(a)		V	Note 1
2	Surge Voltage	U_S	-	$1.3 \times U_R$	V	$T_{amb} \leq +85^\circ\text{C}$
3	Category Voltage	U_C	-	$0.66 \times U_R$	V	
4	Ripple Current	I_{ripple}	-	See Note 2	mA	f = 100kHz, Note 3
5	Operating Temperature Range	T_{op}	-55 to +125		$^\circ\text{C}$	T_{amb}
6	Rated Temperature	T_R	-	+85	$^\circ\text{C}$	
7	Upper Category Temperature	T_C	-	+125	$^\circ\text{C}$	
8	Storage Temperature Range	T_{stg}	-55 to +125		$^\circ\text{C}$	
9	Soldering Temperature	T_{sol}	-	+260	$^\circ\text{C}$	Note 2

NOTES:

- At $T_{amb} \leq +85^\circ\text{C}$. For derating at $T_{amb} > +85^\circ\text{C}$, see Figure 1(a).
- Maximum I_{ripple} , which depends on C_n and U_R , shall be a follows:

Capacitance C_n (μF)	Rated Voltage U_R (V)	Maximum Ripple Current I_{ripple} (mA)
22	6.3	290
47	6.3	410
150	6.3	610
330	6.3	2700
470	6.3	3000
10	10	200
33	10	360
100	10	740
150	10	2400
220	10	2700
330	50	2800
220	12	2800
4.7	16	190
22	16	380
47	16	560
100	16	2200
150	16	2600
3.3	20	170

Capacitance C_n (μF)	Rated Voltage U_R (V)	Maximum Ripple Current I_{ripple} (mA)
10	20	290
22	20	520
33	20	610
47	20	2200
100	20	2500
1	25	160
4.7	25	290
10	25	430
33	25	2000
47	25	2000
3.3	35	290
4.7	35	430
10	35	1500
22	35	1600
33	35	2000
1	50	200
3.3	50	330
4.7	50	1100

3. At $T_{\text{amb}} \leq +25^\circ\text{C}$. For derating at $T_{\text{amb}} > +25^\circ\text{C}$, see Figure 1(b).
4. Duration 5 seconds maximum for wave soldering and 10 seconds maximum for reflow soldering.

FIGURE 1 - PARAMETER DERATING INFORMATION

FIGURE 1(a) - RATED VOLTAGE VERSUS AMBIENT TEMPERATURE

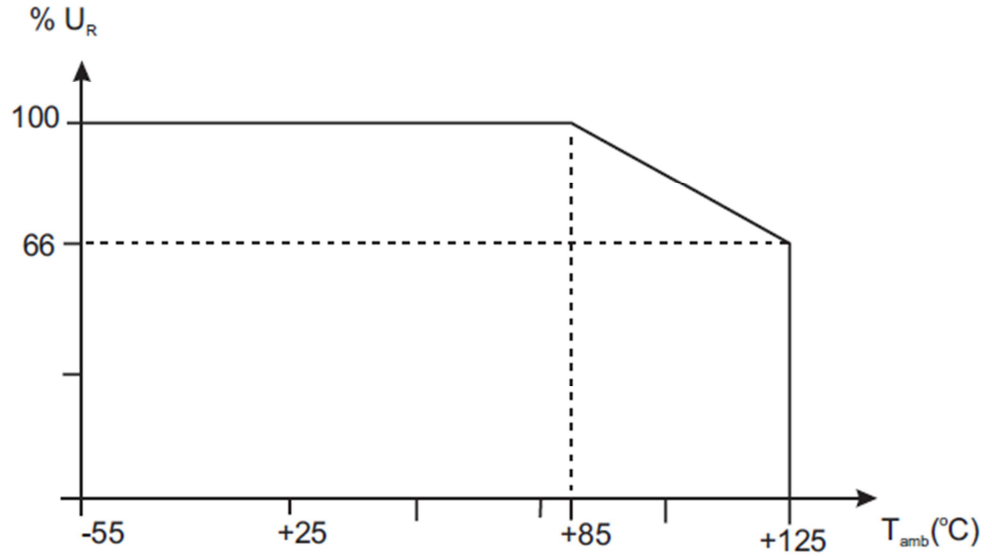

FIGURE 1(b) - MAXIMUM RIPPLE CURRENT VERSUS AMBIENT TEMPERATURE

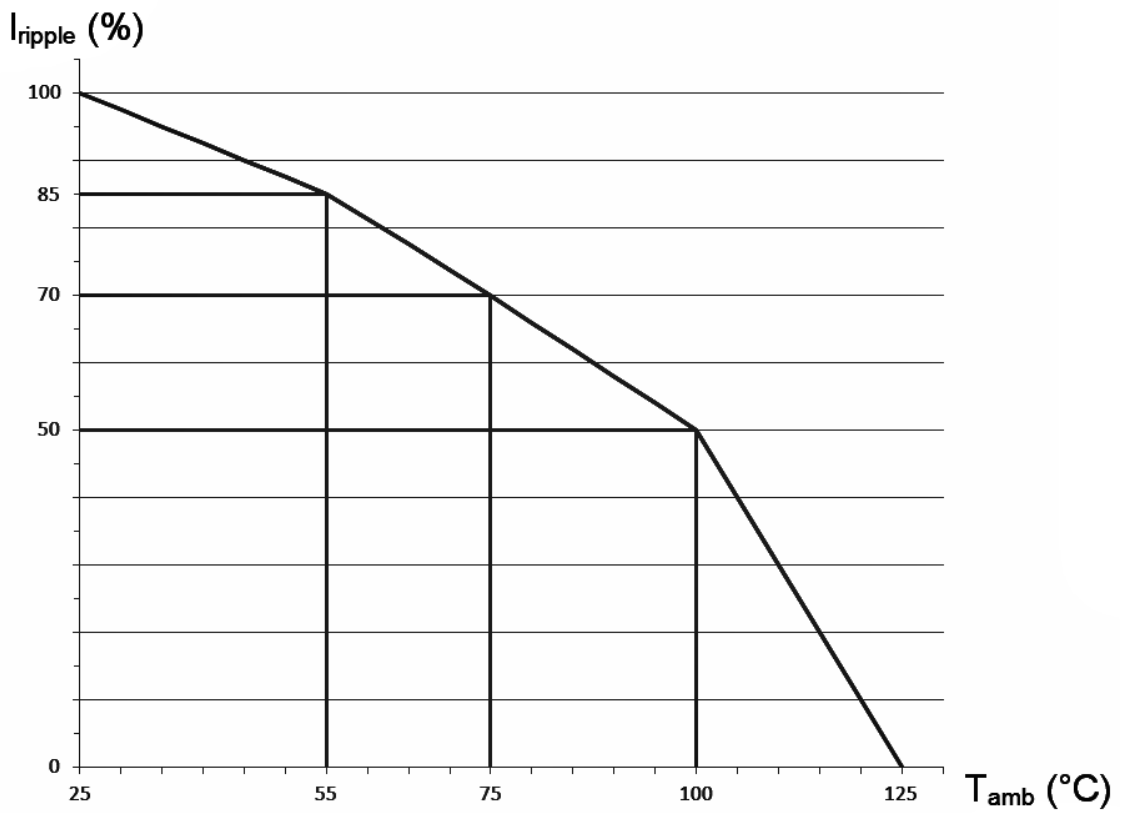
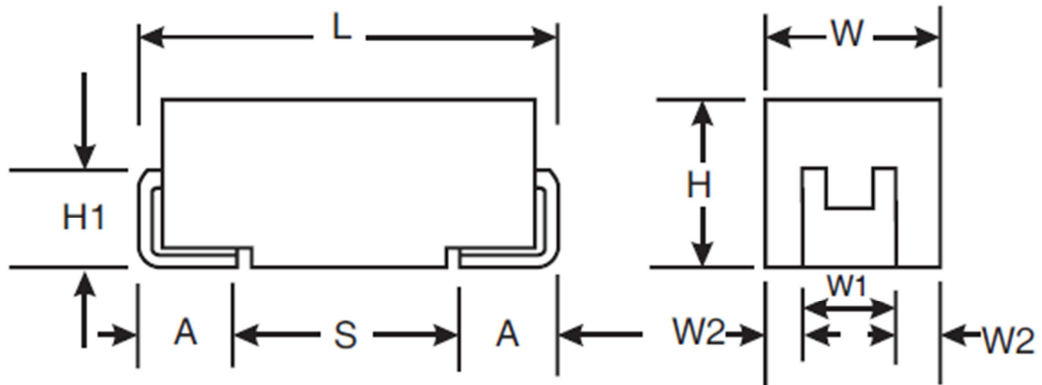
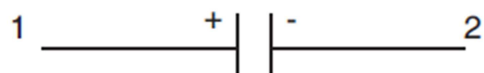

FIGURE 2 - PHYSICAL DIMENSIONS



Variant Number	Case Code	Dimensions (mm)												
		L		W		H	W1		A		S	H1	W2	
		Min	Max	Min	Max	Max	Min	Max	Min	Max	Min	Min	Min	Max
01	A	3	3.4	1.5	1.8	1.8	1	1.4	0.6	1.1	1.1	0.7	0.05	0.4
02	B	3.3	3.7	2.7	3	2.1	2	2.4	0.6	1.1	1.4	0.7	0.15	0.5
03	C	5.8	6.2	3.1	3.4	2.8	2	2.4	1.1	1.6	2.9	0.7	0.35	0.7
04	D	7.1	7.5	4.2	4.5	3.1	2.2	2.6	1.1	1.6	4.4	0.7	0.8	1.15
05	E	7.1	7.5	4.2	4.5	4.3	2.2	2.6	1.1	1.6	4.4	0.7	0.8	1.15

FIGURE 3 - FUNCTIONAL DIAGRAM



Terminal 1: Anode

Terminal 2: Cathode

4 REQUIREMENTS

4.1 GENERAL

The complete requirements for procurement of the components specified herein are stated in this specification and ESCC Generic Specification No. 3012. Deviations from the Generic Specification, applicable to this specification only, are detailed in Para. 4.2.

Deviations from the Generic Specification and this Detail Specification, formally agreed with specific Manufacturers on the basis that the alternative requirements are equivalent to the ESCC requirements and do not affect the components' reliability, are listed in the appendices attached to this specification.

4.2 DEVIATIONS FROM GENERIC SPECIFICATION

4.2.1 Deviations from Special In-Process Controls

None.

4.2.2 Deviations from Final Production Tests (Chart II)

None.

4.2.3 Deviations from Burn-in and Electrical Measurements (Chart III)

None

4.2.4 Deviations from Qualification Tests (Chart IV)

(a) Para. 9.19, Solderability: The solderable area is the termination pad and up to 1/3 the height of the tab.

4.2.5 Deviations from Lot Acceptance Tests (Chart V)

(a) Para. 9.19, Solderability: The solderable area is the termination pad and up to 1/3 the height of the tab.

4.3 MECHANICAL REQUIREMENTS

4.3.1 Dimension Check

The dimensions of the components specified herein shall be verified in accordance with the requirements set out in Para. 9.6 of ESCC Generic Specification No. 3012 and they shall conform to those shown in Figure 2 of this specification.

4.3.2 Weight

The maximum weight of the components specified herein shall be as given in Table 1(a).

4.4 MATERIALS AND FINISHES

The materials and finishes shall be as specified herein. Where a definite material is not specified, a material which will enable the capacitors specified herein to meet the performance requirements of this specification shall be used. Acceptance or approval of any constituent material does not guarantee acceptance of the finished product.

4.4.1 Terminal Material and Finish

The terminal material and finish shall be as specified in Table 1(a) in accordance with the requirements of ESCC Basic Specification No. 23500.

4.5 MARKING

4.5.1 General

The marking of all components delivered to this specification shall be in accordance with the requirements of ESCC Basic Specification No. 21700 and the following paragraphs. When the component is too small to accommodate all of the marking specified, as much as space permits shall be marked and the marking information, in full, shall accompany each component in its primary package.

The information to be marked and the order of precedence, shall be as follows:

- (a) The ESCC Component Number.
- (b) Electrical Characteristics and Ratings.
- (c) Traceability Information.

4.5.2 The ESCC Component Number

The ESCC Component Number shall be constituted and marked as follows:

301200401B

- Detail Specification Number: 3012004
- Type Variant (see Table 1(a)): 01
- Testing Level (B or C, as applicable): B

4.5.3 Electrical Characteristics and Ratings

The electrical characteristics and ratings to be marked in the following order of precedence are:

- (a) Polarity.
- (b) Capacitance Value.
- (c) Tolerance.
- (d) Rated Voltage.
- (e) Equivalent Series Resistance.

The information shall be constituted and marked as follows:

Example: 106KE0600

- Capacitance Value (10 μ F): 106
- Tolerance (\pm 10%): K
- Rated Voltage (25V): E
- Equivalent Series Resistance (600m Ω): 0600

4.5.3.1 *Polarity*

The anode terminal shall be indicated by a polarity stripe marked on the top surface of the component.

4.5.3.2 Capacitance Value

The capacitance value shall be indicated by the following codes. The unit quantity for marking shall be picofarad.

Capacitance C_n (pF)	Code
$XX10^5$	XX5
$XX10^6$	XX6
$XX10^7$	XX7

4.5.3.3 Tolerance

The tolerance on capacitance value shall be indicated by the following code letters.

Tolerance (%)	Code Letter
± 10	K
± 20	M

4.5.3.4 Rated Voltage

The rated voltage shall be indicated by the following code letters.

Rated Voltage U_R (V)	Code Letter
6.3	J
10	A
12	B
16	C
20	D
25	E
35	V
50	T

4.5.3.5 Equivalent Series Resistance

The Equivalent Series Resistance maximum value shall be indicated by the following codes. The unit quantity for marking shall be milliohm.

Equivalent Series Resistance ESR (m Ω)	Code
XX	00XX
XXX	0XXX
XXXX	XXXX

4.5.4 Traceability Information

Traceability information shall be marked in accordance with the requirements of ESCC Basic Specification No. 21700.

4.6 ELECTRICAL MEASUREMENTS

4.6.1 Electrical Measurements at Room Temperature

The parameters to be measured at room temperature are scheduled in Table 2. Unless otherwise specified the measurements shall be performed at $T_{amb} = +22 \pm 3^{\circ}\text{C}$.

4.6.2 Electrical Measurements at High and Low Temperatures

The parameters to be measured at high and low temperatures are scheduled in Table 3.

4.6.3 Circuits for Electrical Measurements (Figure 4)

Not applicable.

4.7 BURN-IN TESTS

4.7.1 Parameter Drift Values

The parameter drift values applicable to Burn-in are as specified in Table 4 of this specification. Unless otherwise stated, measurements shall be performed at $T_{amb} = +22 \pm 3^{\circ}\text{C}$.

The parameter drift values (Δ) applicable to the parameters scheduled shall not be exceeded. In addition to these drift value requirements for a given parameter, the appropriate limit values specified in Table 2 shall not be exceeded.

4.7.2 Conditions for Burn-in

The requirements for Burn-in are specified in Section 7 of ESCC Generic Specification No. 3012. The conditions for Burn-in shall be as specified in Table 5 of this specification.

4.7.3 Electrical Circuit for Burn-in (Figure 5)

Not applicable

TABLE 2 – ELECTRICAL MEASUREMENTS AT ROOM TEMPERATURE

No.	Characteristics	Symbols	ESCC 3012 Test Method	Rated Voltage	Tolerance	Limits		Unit
						Min	Max	
1	Capacitance	C	Para. 9.4.1.1	All	$\pm 10\%$ $\pm 20\%$	$0.9C_n$ $0.8C_n$	$1.1C_n$ $1.2C_n$	μF
2	DC Leakage Current	I_L	Para. 9.4.1.2	All	All	-	$0.01C_n \times U_R$ or (Note 1) 1	μA
3	Dissipation Factor	DF	Para. 9.4.1.3	$U_R < 10\text{V}$ $U_R \geq 10\text{V}$	All	-	10 6	%
4	Equivalent Series Resistance	ESR	Para. 9.4.1.4	All	All	-	Note 2	$\text{m}\Omega$

NOTES:

1. Whichever is greater.
2. See Table 1(a) Note 2.

TABLE 3 - ELECTRICAL MEASUREMENTS AT HIGH AND LOW TEMPERATURES

No.	Characteristics	Symbols	ESCC 3012 Test Method	Test Conditions (Note 1)	Limits		Unit
					Min	Max	
1	Capacitance Change	$\Delta C/C$	Para. 9.4.1.1	$T_{amb} = -55 (+3 -0) ^\circ C$	-10	0	% (Note 2)
				$T_{amb} = +85 \pm 3^\circ C$	0	+10	
				$T_{amb} = +125 (+0 -3) ^\circ C$	0	+12	
2	DC Leakage Current	I_L	Para. 9.4.1.2	$T_{amb} = +85 \pm 3^\circ C$ $V = U_R \pm 2\%$	-	$0.1C_n \times U_R$ or (Note 3) 1	μA
				$T_{amb} = +125 (+0 -3) ^\circ C$ $V = U_C \pm 2\%$	-	$0.125C_n \times U_R$ or (Note 3) 1	
3	Dissipation Factor	DF	Para. 9.4.1.3	$T_{amb} = -55 (+3 -0) ^\circ C$	-	+50	% (Note 2)
				$T_{amb} = +85 \pm 3^\circ C$	-	+50	
				$T_{amb} = +125 (+0 -3) ^\circ C$	-	+100	
4	Equivalent Series Resistance	ESR	Para. 9.4.1.4	$T_{amb} = -55 (+3 -0) ^\circ C$	-	+150	% (Note 2)
				$T_{amb} = +85 \pm 3^\circ C$	-	+50	
				$T_{amb} = +125 (+0 -3) ^\circ C$	-	+50	

NOTES:

1. Inspection level II single sampling, AQL 2.5% for each capacitance value. Each capacitance value shall be considered as constituting a complete lot.
2. Related to the value measured in Table 2.
3. Whichever is greater.

FIGURE 4 - CIRCUITS FOR ELECTRICAL MEASUREMENTS

Not applicable.

TABLE 4 - PARAMETER DRIFT VALUES

No.	Characteristics	Symbol	Spec. and/or Test Method	Test Conditions	Change Limits (Δ)	Unit
1	Capacitance Change	$\Delta C/C$	As per Table 2	As per Table 2	± 5	%
2	DC Leakage Current Change	ΔI_L	As per Table 2	As per Table 2	2 x Initial Value (Note 1) or (Note 2) 0.25 x Table 2 Item 2 + 0.05	μA

NOTES:

1. Leakage currents $< 0.1\mu A$ shall be considered as a $0.1\mu A$ value.
2. Whichever is smaller.

TABLE 5(a) – CONDITIONS FOR BURN-IN

No.	Characteristics	Symbol	Condition	Unit
1	Ambient Temperature	T_{amb}	+85 (+0 -3)	°C
2	Test Voltage	V_T	U_R	V

TABLE 5(b) – CONDITIONS FOR OPERATING LIFE

No.	Characteristics	Symbol	Condition	Unit
1	Ambient Temperature 1	T_{amb1}	+85 (+0 -3)	°C
2	Test Voltage 1	V_{T1}	U_R	V
3	Ambient Temperature 2	T_{amb2}	+125 (+0 -3)	°C
4	Test Voltage 2	V_{T2}	U_C	V

4.8 ENVIRONMENTAL AND ENDURANCE TESTS (CHARTS IV AND V OF ESCC GENERIC SPECIFICATION No. 3012)

4.8.1 Measurements and Inspections on Completion of Environmental Tests

The parameters to be measured and inspections to be performed on completion of environmental tests are scheduled in Table 6. Unless otherwise stated, the measurements shall be performed at $T_{amb} = +22 \pm 3^\circ\text{C}$.

4.8.2 Measurements and Inspections at Intermediate Points During Endurance Tests

The parameters to be measured and inspections to be performed at intermediate points during endurance tests are scheduled in Table 6. Unless otherwise stated, the measurements shall be performed at $T_{amb} = +22 \pm 3^\circ\text{C}$.

4.8.3 Measurements and Inspections on Completion of Endurance Tests

The parameters to be measured and inspections to be performed on completion of endurance tests are scheduled in Table 6. Unless otherwise stated, the measurements shall be performed at $T_{amb} = +22 \pm 3^\circ\text{C}$.

4.8.4 Conditions for Operating Life (Part of Endurance Testing)

The requirements for Operating Life testing are specified in Section 9 of ESCC Generic Specification No. 3012. The conditions for Operating Life testing shall be as specified in Table 5(b) of this specification.

4.8.5 Electrical Circuit for Operating Life Tests (Figure 5)

Not applicable.

TABLE 6 - MEASUREMENTS AND INSPECTIONS ON COMPLETION OF ENVIRONMENTAL TESTS AND AT INTERMEDIATE POINTS AND ON COMPLETION OF ENDURANCE TESTING

No.	ESCC Generic Spec. No. 3012		Measurements and Inspections		Symbols	Limits		Units						
	Environmental and Endurance Tests (Note 1)	Test Methods and Conditions	Identification	Conditions		Min	Max							
01	Mounting	Para. 9.9	Final Examination	Good tinning	-	-	-							
			Terminals											
			Final Measurements											
			Capacitance						Table 2 Item 1	C	-10	+5	%	
			DC Leakage Current						Table 2 Item 2	I _L	-	Table 2	μA	
Dissipation Factor	Table 2 Item 3	DF	-	Table 2	%									
			Equivalent Series Resistance	Table 2 Item 4	ESR	-	1.25 x Table 2	mΩ						
02	Rapid Change of Temperature	Para. 9.3.2	Initial Measurements	Value recorded during Mounting	C	-	-	Table 2	μF					
			Capacitance											
			Final Measurements							Recovery period of 4 hours min.				
			Visual Examination							No corrosion, no damage or obliteration of marking	-	-	-	
			Capacitance Change							Table 2 Item 1	ΔC/C	-5	+5	%
			DC Leakage Current							Table 2 Item 2	I _L	-	Table 2	μA
			Dissipation Factor							Table 2 Item 3	DF	-	Table 2	%
			Equivalent Series Resistance	Table 2 Item 4	ESR	-	1.25 x Table 2	mΩ						
03	External Visual Inspection	Para. 9.5	Final Inspection	ESCC No. 20500	-	-	-							
			External Visual Inspection											
04	Adhesion	Para. 9.10	Initial Measurements	Value recorded during Mounting	C	-	-	Table 2	μF					
			Capacitance											
			Final Measurements							No damage or loosing from the substrate				
Visual Examination	-	-	-											
			Capacitance Change	Table 2 Item 1	ΔC/C	-5	+5	%						

No.	ESCC Generic Spec. No. 3012		Measurements and Inspections		Symbols	Limits		Units
	Environmental and Endurance Tests (Note 1)	Test Methods and Conditions	Identification	Conditions		Min	Max	
05	Vibration	Para. 9.11	Measurements during test	During Last Cycle	-	-	-	
			Final Examination Visual Examination	No intermittent Contact >0.5ms, arcing or open or shorts No damage	-	-	-	
06	Shock or Bump	Para. 9.12	Final Examination Visual Examination	No damage	-	-	-	
07	Climatic Sequence	Para. 9.13	Initial Measurements Capacitance	Value recorded during Mounting	C	Table 2		μF
			Intermediate Measurements DC Leakage Current	During Dry Heat Table 3 Item 2 (Note 2)	I _L	-	Table 3	μA
			Final Measurements External Visual Inspection	After recovery of 1 to 24 tours ESCC No. 20500	-	-	-	
			Capacitance Change	Table 2 Item 1	ΔC/C	-5	+5	%
			DC Leakage Current	Table 2 Item 2	I _L	-	Table 2	μA
			Dissipation Factor	Table 2 Item 3	DF	-	1.25 x Table 2	%
			Equivalent Series Resistance	Table 2 Item 4	ESR	-	1.25 x Table 2	mΩ
08	High and Low Temperature Stability	Para. 9.14	Measurements during test Electrical Measurements	Tables 2 & 3		Tables 2 & 3		
09	Surge Voltage	Para. 9.15	Final Measurements Capacitance Change	Table 2 Item 1	C	Table 2		μF
			DC Leakage Current	Table 2 Item 2	I _L	-	Table 2	μA
			Dissipation Factor	Table 2 Item 3	DF	-	Table 2	%
			Equivalent Series Resistance	Table 2 Item 4	ESR	-	Table 2	mΩ

No.	ESCC Generic Spec. No. 3012		Measurements and Inspections		Symbols	Limits		Units
	Environmental and Endurance Tests (Note 1)	Test Methods and Conditions	Identification	Conditions		Min	Max	
10	Damp Heat Steady State	Para. 9.16	Initial Measurements					
			Capacitance	Value recorded during Mounting	C	Table 2		μF
			Final Measurements	After recovery of 1 to 2 hours				
			Visual Examination	No damage	-	-	-	
			Capacitance Change	Table 2 Item 1	ΔC/C	-10	+10	%
			DC Leakage Current	Table 2 Item 2	I _L	-	1.5 x Table 2	μA
			Dissipation Factor	Table 2 Item 3	DF	-	1.2 x Table 2	%
Equivalent Series Resistance	Table 2 Item 4	ESR	-	1.25 x Table 2	mΩ			
11	Operating Life	Para. 9.17	Initial Measurements					
			Capacitance	Value recorded during Mounting	C	Table 2		μF
			Intermediate Measurements	At 250 and 1000 hrs				
			DC Leakage Current	Table 3 Item 2 (Note 2)	I _L	-	1.25 x Table 3	μA
			Final Measurements	At 1000 and 2000 hrs and after recovery or 1 to 2 hours				
			Capacitance Change	Table 2 Item 1	ΔC/C	-10	+10	%
			DC Leakage Current	Table 2 Item 2	I _L	-	1.25 x Table 2	μA
Dissipation Factor	Table 2 Item 3	DF	-	Table 2	%			
Equivalent Series Resistance	Table 2 Item 4	ESR	-	1.25 x Table 2	mΩ			
Visual Examination	No damage	-	-	-				
12	Permanence of Marking	Para. 9.18	Final Examination					
			Visual Examination	ESCC No. 24800	-	-	-	
13	Solderability	Para. 9.19, 4.2.4 and 4.2.5 of this spec	Final Examination					
			Visual Examination	ESCC No. 3012 Para. 9.13.3 and no damage	-	-	-	

NOTES:

1. The tests in this Table refer to either Chart IV or V and shall be used as applicable.
2. While still at the high temperature.

APPENDIX 'A'**AGREED DEVIATIONS FOR AVX CZECH REPUBLIC s.r.o (CZ)**

Items Affected	Description of Deviations
Deviations from Final Production Tests (Chart II)	Para. 9.1, Internal Visual Inspection: Shall not be performed. Para. 9.5, External Visual Inspection: Visible base material is permitted on the edges of terminations (there is no plating on edges).
Deviations from Burn-in and Electrical Measurements (Chart III)	Para. 9.5, External Visual Inspection: Visible base material is permitted on the edges of terminations (there is no plating on edges).
Deviations from Qualification Tests (Chart IV)	Para. 9.5, External Visual Inspection: Visible base material is permitted on the edges of terminations (there is no plating on edges).
Deviations from Lot Acceptance Tests (Chart V)	Para. 9.5, External Visual Inspection: Visible base material is permitted on the edges of terminations (there is no plating on edges).