



Page 1 of 16

**RESISTORS, HEATERS, FLEXIBLE,
SINGLE AND DOUBLE LAYER**

ESCC Detail Specification No. 4009/002

Issue 7	January 2014
---------	--------------



Document Custodian: European Space Agency – see <https://escies.org>

LEGAL DISCLAIMER AND COPYRIGHT

European Space Agency, Copyright © 2014. All rights reserved.

The European Space Agency disclaims any liability or responsibility, to any person or entity, with respect to any loss or damage caused, or alleged to be caused, directly or indirectly by the use and application of this ESCC publication.

This publication, without the prior permission of the European Space Agency and provided that it is not used for a commercial purpose, may be:

- copied in whole, in any medium, without alteration or modification.
- copied in part, in any medium, provided that the ESCC document identification, comprising the ESCC symbol, document number and document issue, is removed.

DOCUMENTATION CHANGE NOTICE

(Refer to <https://escies.org> for ESCC DCR content)

DCR No.	CHANGE DESCRIPTION
828	Specification upissued to incorporate changes per DCR. Specification converted to MSWord. Changes in presentation are possible.

TABLE OF CONTENTS

1	GENERAL	5
1.1	SCOPE	5
1.2	APPLICABLE DOCUMENTS	5
1.3	TERMS, DEFINITIONS, ABBREVIATIONS, SYMBOLS AND UNITS	5
1.4	THE ESCC COMPONENT NUMBER AND COMPONENT TYPE VARIANTS	5
1.4.1	The ESCC Component Number	5
1.4.2	Component Type Variants and Range of Components	5
1.4.3	Manufacturer Specific Heater Identification	8
1.5	MAXIMUM RATINGS	9
1.6	PHYSICAL DIMENSIONS AND HEATER OUTLINE	9
1.6.1	Heater Thickness	11
1.7	MATERIALS AND FINISHES	11
1.7.1	Heater Resistive Element	11
1.7.2	Strip Heater Bridging Tabs	11
1.7.3	Protective Coating	11
1.7.4	Terminal Leads	11
2	REQUIREMENTS	11
2.1	GENERAL	11
2.1.1	Deviations from the Generic Specification	12
2.1.1.1	Deviations from Screening Tests - Chart F3	12
2.2	MARKING	12
2.3	ROBUSTNESS OF TERMINATIONS	12
2.4	ELECTRICAL MEASUREMENTS AT ROOM, HIGH AND LOW TEMPERATURES	13
2.4.1	Room Temperature Electrical Measurements	13
2.4.2	High and Low Temperatures Electrical Measurements	13
2.5	INTERMEDIATE AND END-POINT ELECTRICAL MEASUREMENTS	14
2.6	BURN-IN CONDITIONS	15
2.7	OPERATING LIFE CONDITIONS	15
	APPENDIX A	16

1 GENERAL

1.1 SCOPE

This specification details the ratings, physical and electrical characteristics and test and inspection data for the component type variants and/or the range of components specified below. It supplements the requirements of, and shall be read in conjunction with, the ESCC Generic Specification listed under Applicable Documents.

1.2 APPLICABLE DOCUMENTS

The following documents form part of this specification and shall be read in conjunction with it:

- (a) ESCC Generic Specification No. 4009.
- (b) MIL-P-46112: Military Specification for Polyimide Plastic Sheet and Strip.
- (c) ASTM-D5213: Standard Specification for Polymeric Resin Film for Electrical Insulation and Dielectric Applications.

1.3 TERMS, DEFINITIONS, ABBREVIATIONS, SYMBOLS AND UNITS

For the purpose of this specification, the terms, definitions, abbreviations, symbols and units specified in ESCC Basic Specification No. 21300 shall apply.

1.4 THE ESCC COMPONENT NUMBER AND COMPONENT TYPE VARIANTS

1.4.1 The ESCC Component Number

The ESCC Component Number shall be constituted as follows:

Example: 400900201A1234

- Detail Specification Reference: 4009002
- Component Type Variant Number: 01 (as required)
- Manufacturer Specific Heater Identification: A1234 (as applicable) where:
 - A: First letter of the applicable Manufacturer's name
 - 1234: A unique 4 digit number, sequentially allocated by the applicable Manufacturer to a specific heater design.

1.4.2 Component Type Variants and Range of Components

The component type variants and range of components applicable to this specification are as follows:

Variant	Heater Type and Construction (Note 1)	Terminal Leads		Resistance Range Rn (Ω)	Resistance Tolerance (± %)	Heating Area S (cm ²) (Note 1)	Resistance Density (Ω/cm ²)	Temperature Coefficient (10 ⁻⁶ /°C)	Weight Max (g)
		Wire Gauge (AWG)	Configuration (Note 2)						
01	Individual or Strip, Single Layer	20	Straight	1 to 5000	2, 3, 5, 10	Note 3	≤ 200	175	Note 4
02	Individual or Strip, Single Layer	22	Straight	1 to 5000	2, 3, 5, 10	Note 3	≤ 200	175	Note 4
03	Individual or Strip, Single Layer	24	Straight	1 to 5000	2, 3, 5, 10	Note 3	≤ 200	175	Note 4

Variant	Heater Type and Construction (Note 1)	Terminal Leads		Resistance Range Rn (Ω)	Resistance Tolerance (± %)	Heating Area S (cm ²) (Note 1)	Resistance Density (Ω/cm ²)	Temperature Coefficient (10 ⁻⁶ /°C)	Weight Max (g)
		Wire Gauge (AWG)	Configuration (Note 2)						
04	Individual or Strip, Single Layer	26	Straight	1 to 5000	2, 3, 5, 10	Note 3	≤ 200	175	Note 4
05	Individual or Strip, Single Layer	28	Straight	1 to 5000	2, 3, 5, 10	Note 3	≤ 200	175	Note 4
06	Individual or Strip, Single Layer	30	Straight	1 to 5000	2, 3, 5, 10	Note 3	≤ 200	175	Note 4
07	Individual or Strip, Single Layer	20	UTP	1 to 5000	2, 3, 5, 10	Note 3	≤ 200	175	Note 4
08	Individual or Strip, Single Layer	22	UTP	1 to 5000	2, 3, 5, 10	Note 3	≤ 200	175	Note 4
09	Individual or Strip, Single Layer	24	UTP	1 to 5000	2, 3, 5, 10	Note 3	≤ 200	175	Note 4
10	Individual or Strip, Single Layer	26	UTP	1 to 5000	2, 3, 5, 10	Note 3	≤ 200	175	Note 4
11	Individual or Strip, Single Layer	28	UTP	1 to 5000	2, 3, 5, 10	Note 3	≤ 200	175	Note 4
12	Individual or Strip, Single Layer	30	UTP	1 to 5000	2, 3, 5, 10	Note 3	≤ 200	175	Note 4
13	Individual or Strip, Single Layer	20	JTP	1 to 5000	2, 3, 5, 10	Note 3	≤ 200	175	Note 4
14	Individual or Strip, Single Layer	22	JTP	1 to 5000	2, 3, 5, 10	Note 3	≤ 200	175	Note 4
15	Individual or Strip, Single Layer	24	JTP	1 to 5000	2, 3, 5, 10	Note 3	≤ 200	175	Note 4
16	Individual or Strip, Single Layer	26	JTP	1 to 5000	2, 3, 5, 10	Note 3	≤ 200	175	Note 4
17	Individual or Strip, Single Layer	28	JTP	1 to 5000	2, 3, 5, 10	Note 3	≤ 200	175	Note 4
18	Individual or Strip, Single Layer	30	JTP	1 to 5000	2, 3, 5, 10	Note 3	≤ 200	175	Note 4
19	Individual or Strip, Single Layer	20	STP	1 to 5000	2, 3, 5, 10	Note 3	≤ 200	175	Note 4
20	Individual or Strip, Single Layer	22	STP	1 to 5000	2, 3, 5, 10	Note 3	≤ 200	175	Note 4
21	Individual or Strip, Single Layer	24	STP	1 to 5000	2, 3, 5, 10	Note 3	≤ 200	175	Note 4
22	Individual or Strip, Single Layer	26	STP	1 to 5000	2, 3, 5, 10	Note 3	≤ 200	175	Note 4
23	Individual or Strip, Single Layer	28	STP	1 to 5000	2, 3, 5, 10	Note 3	≤ 200	175	Note 4
24	Individual or Strip, Single Layer	30	STP	1 to 5000	2, 3, 5, 10	Note 3	≤ 200	175	Note 4

Variant	Heater Type and Construction (Note 1)	Terminal Leads		Resistance Range Rn (Ω)	Resistance Tolerance (± %)	Heating Area S (cm ²) (Note 1)	Resistance Density (Ω/cm ²)	Temperature Coefficient (10 ⁻⁶ /°C)	Weight Max (g)
		Wire Gauge (AWG)	Configuration (Note 2)						
25	Individual, Double Layer	20	Straight	1 to 5000	2, 3, 5, 10	Note 3	≤ 200	175	Note 4
26	Individual, Double Layer	22	Straight	1 to 5000	2, 3, 5, 10	Note 3	≤ 200	175	Note 4
27	Individual, Double Layer	24	Straight	1 to 5000	2, 3, 5, 10	Note 3	≤ 200	175	Note 4
28	Individual, Double Layer	26	Straight	1 to 5000	2, 3, 5, 10	Note 3	≤ 200	175	Note 4
29	Individual, Double Layer	28	Straight	1 to 5000	2, 3, 5, 10	Note 3	≤ 200	175	Note 4
30	Individual, Double Layer	30	Straight	1 to 5000	2, 3, 5, 10	Note 3	≤ 200	175	Note 4
31	Individual, Double Layer	20	UTP	1 to 5000	2, 3, 5, 10	Note 3	≤ 200	175	Note 4
32	Individual, Double Layer	22	UTP	1 to 5000	2, 3, 5, 10	Note 3	≤ 200	175	Note 4
33	Individual, Double Layer	24	UTP	1 to 5000	2, 3, 5, 10	Note 3	≤ 200	175	Note 4
34	Individual, Double Layer	26	UTP	1 to 5000	2, 3, 5, 10	Note 3	≤ 200	175	Note 4
35	Individual, Double Layer	28	UTP	1 to 5000	2, 3, 5, 10	Note 3	≤ 200	175	Note 4
36	Individual, Double Layer	30	UTP	1 to 5000	2, 3, 5, 10	Note 3	≤ 200	175	Note 4
37	Individual, Double Layer	20	JTP	1 to 5000	2, 3, 5, 10	Note 3	≤ 200	175	Note 4
38	Individual, Double Layer	22	JTP	1 to 5000	2, 3, 5, 10	Note 3	≤ 200	175	Note 4
39	Individual, Double Layer	24	JTP	1 to 5000	2, 3, 5, 10	Note 3	≤ 200	175	Note 4
40	Individual, Double Layer	26	JTP	1 to 5000	2, 3, 5, 10	Note 3	≤ 200	175	Note 4
41	Individual, Double Layer	28	JTP	1 to 5000	2, 3, 5, 10	Note 3	≤ 200	175	Note 4
42	Individual, Double Layer	30	JTP	1 to 5000	2, 3, 5, 10	Note 3	≤ 200	175	Note 4
43	Individual, Double Layer	20	STP	1 to 5000	2, 3, 5, 10	Note 3	≤ 200	175	Note 4
44	Individual, Double Layer	22	STP	1 to 5000	2, 3, 5, 10	Note 3	≤ 200	175	Note 4
45	Individual, Double Layer	24	STP	1 to 5000	2, 3, 5, 10	Note 3	≤ 200	175	Note 4

Variant	Heater Type and Construction (Note 1)	Terminal Leads		Resistance Range Rn (Ω)	Resistance Tolerance (± %)	Heating Area S (cm ²) (Note 1)	Resistance Density (Ω/cm ²)	Temperature Coefficient (10 ⁻⁶ /°C)	Weight Max (g)
		Wire Gauge (AWG)	Configuration (Note 2)						
46	Individual, Double Layer	26	STP	1 to 5000	2, 3, 5, 10	Note 3	≤ 200	175	Note 4
47	Individual, Double Layer	28	STP	1 to 5000	2, 3, 5, 10	Note 3	≤ 200	175	Note 4
48	Individual, Double Layer	30	STP	1 to 5000	2, 3, 5, 10	Note 3	≤ 200	175	Note 4

NOTES

1. See Physical Dimensions and Heater Outline.
2. UTP = Unjacketed Twisted Pair; JTP = Jacketed Twisted Pair; STP = Shielded Twisted Pair.
3. The Heating Area, S, shall be:
 - Individual, single layer heaters: 1.6 to 1300cm²
 - Strip, single layer heaters: 3.2 to 312cm²
 - Individual, double layer heaters: 1.6 to 1300cm²
4. The total maximum weight of the heaters, excluding the weight of the terminal leads, shall be:
 - Individual or Strip, single layer heaters: 50mg/cm²
 - Individual, double layer heaters: 75mg/cm²
 The weight of the terminal leads shall be as specified in the applicable wire ESCC Detail Specification.

1.4.3 Manufacturer Specific Heater Identification

A Heater Design Drawing shall be produced by the Manufacturer after negotiation with the Orderer and shall be held under configuration control by the Manufacturer who will allocate a unique Manufacturer Specific Heater Identification sequentially when a request for a heater is received.

Each Heater Design Drawing shall include the following information:

- (a) The heater outline and dimensions as required by Physical Dimensions and Heater Outline herein. This shall include details of the heater type and construction, and the terminal leads configurations including the angle of exit of each terminal lead with respect to the heater body.
- (b) The ESCC Component Number for the heater, including the Manufacturer Specific Heater Identification.
- (c) The terminal leads' ESCC Detail Specification and Component Number.
- (d) The heater electrical information as follows:
 - Resistance value Rn and tolerance by circuit at T_{amb} = +22 ±3°C.
 - Maximum rated power in still air at T_{amb} = +25°C.
- (e) Track width and spacing with tolerances.
- (f) Cover material (if fitted).
- (g) Pressure sensitive tape (if fitted).
- (h) Dimensions of pre-form, if required.

1.5 MAXIMUM RATINGS

The maximum ratings shall not be exceeded at any time during use or storage.

Maximum ratings shall only be exceeded during testing to the extent specified in this specification and when stipulated in Test Methods and Procedures of the ESCC Generic Specification.

Characteristics	Symbols	Maximum Ratings	Units	Remarks
Rated Power Density	P _n	0.54	W/cm ²	Notes 1, 2, 3, 4
Operating Temperature Range	T _{op}	-65 to +200	°C	T _{amb} Note 3
Storage Temperature Range	T _{stg}	-65 to +200	°C	-
Rated Voltage	U _R	$\sqrt{P_n \cdot R_n \cdot S}$	V	Notes 2, 3, 5

NOTES:

- With heater suspended in still air at T_{amb} = +25°C.
- Actual rated power shall be specified in the applicable Heater Design Drawing. It shall be determined from the Heating Area (S) in cm².
- Rated Power Density shall be derated against temperature and Heating Area as follows:
 - P_n = 0.54W/cm² for T_{amb} ≤ +25°C. Derate to 0W/cm² at 0.00308W/cm²/°C for +25°C < T_{amb} ≤ +200°C.
 - P_n = 0.54W/cm² for 1.6cm² ≤ Heating Area (S) ≤ 300cm². Derate to 0.3W/cm² at 0.00024W/cm²/cm² for 300cm² < Heating Area (S) ≤ 1300cm².
- The following design rule shall be applied:

Area of Heater Resistive Element ÷ Heating Area (S) = 50 ±10%
- R_n is the nominal resistance.

1.6 PHYSICAL DIMENSIONS AND HEATER OUTLINE

The general physical dimensions and heater layout shall be as follows. The heater type, construction, physical dimensions and heater layout applicable to a specific heater will be specified in the Heater Design Drawing held by the Manufacturer.

INDIVIDUAL HEATER

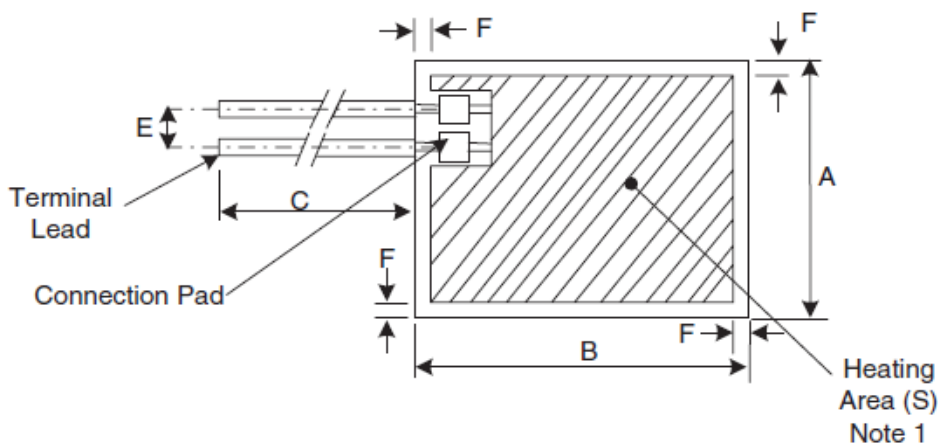

STRIP HEATER (NOTE 2)

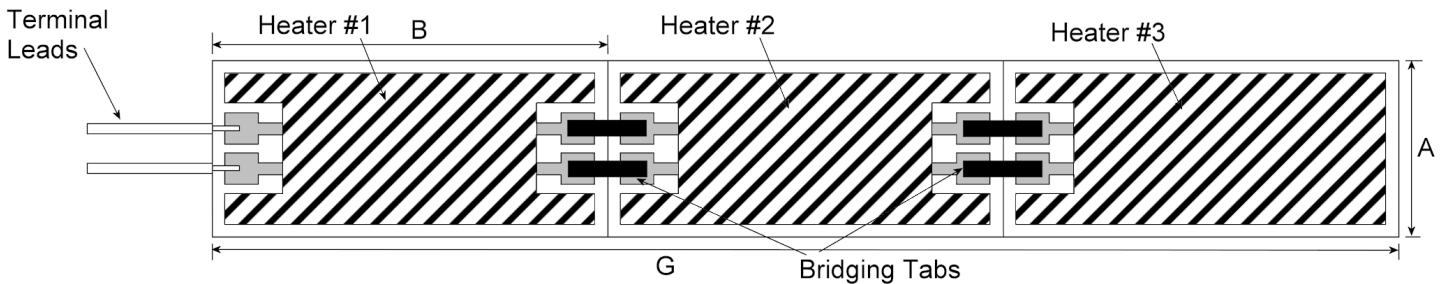

Symbol	Dimensions mm		Tolerance ± mm	Heater Type	Remarks
	Min	Max			
A	6	590	0.5	Individual	
	6	15	0.5	Strip	Note 3
B	8	600	0.5	Individual	
	300	590	0.5	Strip	Note 4
C	300	-	Note 5	Individual & Strip	
E	2	-	Note 6	Individual & Strip	Note 7
F	0.4	-	-	Individual & Strip	Notes 8, 9
G	610	2500	0.5	Strip	Note 10
S	Note 1		-	Individual & Strip	Note 1

NOTES

1. The Heating Area, S, is defined as the total area of the heater excluding the peripheral margin, and the terminal lead and/or bridging tab connection areas. For Strip heaters, the Heating Area is the total for all the individual heaters connected together. The acceptable limits of S are specified in Component Type Variants and Range of Components.
2. A Strip heater is made up of 2 to 5 individual, single layer heaters connected together in series by means of bridging tabs welded to each individual heater's connection pads.
3. Strip heater width. All individual heaters in the Strip heater shall have the same width.
4. The length of each individual heater in the Strip heater.
5. The tolerance shall be ±10% on the required dimension.
6. The tolerance shall be ±0.5mm on the required dimension.
7. Terminal lead spacing shall be measured at the terminal lead connection area. Terminal leads may exit the terminal lead connection area at any angle. The terminal leads may be located on any side of the heater. There may be more than 2 terminal leads (for multiple resistive element and double layer heaters).
8. Peripheral margin dimension.
9. Perforated holes in the peripheral margin are allowed provided that the distance between the edge of the hole and the heater resistive element or connection pad is equal to, or greater than, dimension F.
10. The total length of the Strip heater.

1.6.1 Heater Thickness

The maximum thicknesses for single layer and double layer heaters are as follows:

- 0.2mm maximum for Individual or Strip, single layer heaters.
- 0.3mm maximum for Individual, double layer heaters.

These maximum limits do not apply over the terminal lead and/or bridging tab connection areas.

1.7 MATERIALS AND FINISHES

1.7.1 Heater Resistive Element

The heater resistive element shall be made of flexible nickel/chromium/iron alloy (76/16/8 Inconel).

1.7.2 Strip Heater Bridging Tabs

Bridging Tabs used to connect individual heaters to form a Strip heater shall be made of flexible nickel/chromium/iron alloy (76/16/8 Inconel). They shall be electrically welded to the heater resistive elements.

1.7.3 Protective Coating

Heater resistive elements, terminal leads connections and, for Strip heaters, bridging tabs connections shall be completely coated with Polyimide Polymer/FEP in accordance with MIL-P-46112 (as superseded by ASTM-D5213).

1.7.4 Terminal Leads

Terminal leads shall be made of multi-strand silver-plated copper in accordance with ESCC Generic Specification No. 3901. The applicable Heater Design Drawing shall specify the wire ESCC Detail Specification and the wire ESCC Component Number. The wire gauge shall be as specified in Component Type Variants and Range of Components herein. Terminal leads shall be electrically welded to the heater resistive element.

2 REQUIREMENTS

2.1 GENERAL

The complete requirements for procurement of the components specified herein are as stated in this specification and the ESCC Generic Specification. Permitted deviations from the Generic Specification, applicable to this specification only, are listed below.

Permitted deviations from the Generic Specification and this Detail Specification, formally agreed with specific Manufacturers on the basis that the alternative requirements are equivalent to the ESCC requirement and do not affect the component's reliability, are listed in the appendices attached to this specification.

2.1.1 Deviations from the Generic Specification

2.1.1.1 *Deviations from Screening Tests - Chart F3*

- (a) For heaters where the Heater Design Drawing requires the application of cover material or pressure sensitive tape the following additional steps shall be performed during Screening Tests:
- (i) An additional 100% External Visual Inspection shall be performed after successful completion of High and Low Temperatures Electrical Measurements.
 - (ii) After successful completion of the additional External Visual Inspection the cover material and/or pressure sensitive tape shall be applied.
For heaters which already have a backing foil applied the additional External Visual Inspection shall not be performed.
- (b) For heaters where the Heater Design Drawing requires pre-forming this shall be performed on successful completion of Screening Tests. The pre-forming operation shall be performed at a temperature not exceeding the maximum storage temperature. An additional External Visual Inspection shall be performed after the pre-forming operation to check for any damage.

2.2 MARKING

The marking shall be in accordance with the requirements of ESCC Basic Specification No. 21700 and as follows.

The information to be marked on the component shall be:

- (a) The ESCC qualified components symbol (for ESCC qualified components only).
- (b) The ESCC Component Number.
- (c) Traceability information.

2.3 ROBUSTNESS OF TERMINATIONS

The test conditions for robustness of terminations, tested as specified in the ESCC Generic Specification, shall be as follows and apply to a single terminal lead at a time.

Wire Gauge (AWG)	20	22	24	26	28	30
Pull Strength (N)	45	36	22	13	9	4.5
Duration (s) minimum	5	5	5	5	5	5

2.4 ELECTRICAL MEASUREMENTS AT ROOM, HIGH AND LOW TEMPERATURES

The measurements shall be performed at room, high and low temperatures.

2.4.1 Room Temperature Electrical Measurements

The measurements shall be performed at $T_{amb} = +22 \pm 3^{\circ}C$.

Characteristics	Symbols	Test Method and Conditions	Limits		Units
			Min	Max	
Resistance	R_A	ESCC No. 4009 ±2% Tolerance ±3% Tolerance ±5% Tolerance ±10% Tolerance	0.98 Rn 0.97 Rn 0.95 Rn 0.9 Rn	1.02 Rn 1.03 Rn 1.05 Rn 1.1 Rn	Ω
Insulation Resistance	R_I	ESCC No. 4009	1000	-	M Ω
Voltage Proof Leakage Current	I_L	ESCC No. 4009 Test Voltage = 500Vrms	-	2 or (1) 4	mA $\mu A/cm^2$

NOTES

1. Whichever is greater based on the Heating Area.

2.4.2 High and Low Temperatures Electrical Measurements

Characteristics	Symbols	Test Method and Conditions (Note 1)	Limits		Units
			Min	Max	
Resistance change between -65 (+3 -0) $^{\circ}C$ and +22 $\pm 3^{\circ}C$	$\Delta R_A/R_A(L)$	ESCC No. 4009	0	-1.57	%
Resistance change between +200 (+0 -3) $^{\circ}C$ and +22 $\pm 3^{\circ}C$	$\Delta R_A/R_A(H)$	ESCC No. 4009	0	+3.17	%

NOTES

1. Measurements shall be performed during Screening Tests on a sample of 3 components. In the event of any failure a 100% inspection shall be performed.

2.5 INTERMEDIATE AND END-POINT ELECTRICAL MEASUREMENTS

Unless otherwise specified, the measurements shall be performed at $T_{amb} = +22 \pm 3^{\circ}C$.

The test methods and test conditions shall be as per the corresponding test defined in Room Temperature Electrical Measurements.

The drift values (Δ) shall not be exceeded for each characteristic where specified. The corresponding absolute limit values for each characteristic shall not be exceeded.

Test Reference per ESCC No. 4009	Characteristics	Symbols	Limits		Units	
			Min.	Max.		
Robustness of Terminations	Initial Measurements	Resistance R_A	$\pm 2\%$ Tolerance	0.98 Rn	1.02 Rn	Ω
			$\pm 3\%$ Tolerance	0.97 Rn	1.03 Rn	
			$\pm 5\%$ Tolerance	0.95 Rn	1.05 Rn	
			$\pm 10\%$ Tolerance	0.9 Rn	1.1 Rn	
	Final Measurements	Resistance R_A	$\pm 2\%$ Tolerance	0.98 Rn	1.02 Rn	Ω
			$\pm 3\%$ Tolerance	0.97 Rn	1.03 Rn	
			$\pm 5\%$ Tolerance	0.95 Rn	1.05 Rn	
			$\pm 10\%$ Tolerance	0.9 Rn	1.1 Rn	
			Change in Resistance $\Delta R_A/R_A$	-	± 1	
Climatic Sequence	Initial Measurements	Resistance R_A	$\pm 2\%$ Tolerance	0.98 Rn	1.02 Rn	Ω
			$\pm 3\%$ Tolerance	0.97 Rn	1.03 Rn	
			$\pm 5\%$ Tolerance	0.95 Rn	1.05 Rn	
			$\pm 10\%$ Tolerance	0.9 Rn	1.1 Rn	
	Final Measurements	Resistance R_A	$\pm 2\%$ Tolerance	0.98 Rn	1.02 Rn	Ω
			$\pm 3\%$ Tolerance	0.97 Rn	1.03 Rn	
			$\pm 5\%$ Tolerance	0.95 Rn	1.05 Rn	
			$\pm 10\%$ Tolerance	0.9 Rn	1.1 Rn	
			Change in Resistance $\Delta R_A/R_A$	-	± 2	
Insulation Resistance R_I	1000	-	M Ω			
Voltage Proof Leakage Current (Test Voltage: 500Vrms) I_L	-	2 or (1) 4	mA $\mu A/cm^2$			

Test Reference per ESCC No. 4009	Characteristics	Symbols	Limits		Units			
			Min.	Max.				
Operating Life	Initial Measurements (0 hours)	Resistance R_A	$\pm 2\%$ Tolerance	0.98 Rn	1.02 Rn	Ω		
			$\pm 3\%$ Tolerance	0.97 Rn	1.03 Rn			
			$\pm 5\%$ Tolerance	0.95 Rn	1.05 Rn			
			$\pm 10\%$ Tolerance	0.9 Rn	1.1 Rn			
	Intermediate Measurements (1000 hours)	Resistance R_A	$\pm 2\%$ Tolerance	0.98 Rn	1.02 Rn	Ω		
			$\pm 3\%$ Tolerance	0.97 Rn	1.03 Rn			
			$\pm 5\%$ Tolerance	0.95 Rn	1.05 Rn			
			$\pm 10\%$ Tolerance	0.9 Rn	1.1 Rn			
	Final Measurements (2000 hours)	Change in Resistance $\Delta R_A/R_A$		-	± 1.4	%		
			Resistance R_A	$\pm 2\%$ Tolerance	0.98 Rn		1.02 Rn	Ω
			$\pm 3\%$ Tolerance	0.97 Rn	1.03 Rn			
			$\pm 5\%$ Tolerance	0.95 Rn	1.05 Rn			
$\pm 10\%$ Tolerance	0.9 Rn	1.1 Rn						
Final Measurements (2000 hours)	Change in Resistance (related to 0 hours) $\Delta R_A/R_A$		-	± 2	%			
		Insulation Resistance R_I		1000		-	M Ω	
		Voltage Proof Leakage Current I_L		-		2		mA
		(Test Voltage: 500Vrms)				or (1) 4		

NOTES

1. Whichever is greater based on the Heating Area.

2.6

BURN-IN CONDITIONS

Characteristics	Symbols	Test Conditions	Units
Heater Temperature	T_{HTR}	+200 (Note 1)	$^{\circ}C$
Power Density	P_n	0.54 (Note 1)	W/cm ²

NOTES

1. Voltage shall be applied until either the specified heater temperature or the power density is reached.

2.7

OPERATING LIFE CONDITIONS

The conditions shall be as specified for Burn-in.

APPENDIX A
AGREED DEVIATIONS FOR RICA (I)

ITEMS AFFECTED	DESCRIPTION OF DEVIATIONS
Deviations from the Generic Specification	Qualification and Periodic Tests - Chart F4: The specified period for the Endurance Subgroup shall be 24 months.
Deviations from Screening Tests - Chart F3	Heaters with cover material applied: Where cover material has been applied during the heater lamination process, the deviations specified in Para. 2.1.1.1(a) of this specification are not applicable.
	Serialisation: A 100% serialisation, performed prior to Screening Tests with subsequent Electrical Measurements at Room, High and Low Temperatures performed read and record, is optional at the Manufacturer's discretion.
	Para. 8.2, Rapid Change of Temperature: Mounting: Heaters may be mounted using any suitable method. Data Points: Electrical measurements during and after testing are optional at the Manufacturer's discretion.
	Para. 8.3, Overload: Data Points: Electrical measurements after testing are optional at the Manufacturer's discretion.