



**INTERNAL VISUAL INSPECTION
OF CAPACITORS**

ESCC Basic Specification No. 2043000

Issue 3	February 2014
---------	---------------



LEGAL DISCLAIMER AND COPYRIGHT

European Space Agency, Copyright © 2014. All rights reserved.

The European Space Agency disclaims any liability or responsibility, to any person or entity, with respect to any loss or damage caused, or alleged to be caused, directly or indirectly by the use and application of this ESCC publication.

This publication, without the prior permission of the European Space Agency and provided that it is not used for a commercial purpose, may be:

- copied in whole, in any medium, without alteration or modification.
- copied in part, in any medium, provided that the ESCC document identification, comprising the ESCC symbol, document number and document issue, is removed.

DOCUMENTATION CHANGE NOTICE

(Refer to <https://escies.org> for ESCC DCR content)

DCR No.	CHANGE DESCRIPTION
838	Specification upissued to incorporate editorial changes per DCR.

TABLE OF CONTENTS

1	SCOPE	6
2	GENERAL REQUIREMENTS	6
2.1	APPLICABILITY	6
2.2	PROCEDURE	6
2.3	MAGNIFICATION	6
2.4	MOUNTING FIXTURES	6
3	DETAILED REQUIREMENTS	6
3.1	GENERAL	6
3.2	TANTALUM CAPACITORS (SOLID/WET/CHIP)	7
3.2.1	Tantalum Pellet (See Figure 1 Para. 4.1)	7
3.2.2	Termination (See Figure 2 Para. 4.2)	7
3.3	PLASTIC-DIELECTRIC CAPACITORS	7
3.3.1	Termination Clearance (See Figure 3 Para. 4.3)	7
3.3.2	Terminal Leads	7
3.3.3	Insulation (See Figure 4 Para. 4.4)	7
3.3.4	Winding	7
3.4	MICA-DIELECTRIC CAPACITORS	7
3.4.1	Lead Conditions	7
3.4.2	Lead Welding	7
3.4.3	Contact Area between Mica Plates (See Figure 5 Para. 4.5)	8
3.4.4	Mica Plates	8
3.5	FILTER/FEED-THROUGH CAPACITORS (CERAMIC-DIELECTRIC)	8
3.5.1	Discoidal Capacitors (See Figure 6 Para. 4.6)	8
3.5.2	Tubular Capacitors (See Figure 7 Para. 4.7)	8
3.5.3	Ferrite Sleeve (Inductive Element)	8
3.5.4	Coils (Inductive Element)	8
3.5.5	Metal-plated Parts	8
3.5.6	Sub-assembly or Pre-encapsulation Inspection	8
3.6	CERAMIC-DIELECTRIC NON-FEED-THROUGH CAPACITORS	9
3.6.1	Ceramic Surface Defects (See Figures 8 and 9 Paras. 4.8 and 4.9)	9
3.6.2	End Metallisation Defects (See Figures 10 and 11 Paras. 4.10 and 4.11)	9
3.6.3	Terminal Lead Defects (See Figures 12 to 16 Paras. 4.12 to 4.16)	9
4	FIGURES	10
4.1	FIGURE 1: TANTALUM PELLETT	10
4.2	FIGURE 2: TERMINATION	10

4.3	FIGURE 3: TERMINATION CLEARANCE	11
4.4	FIGURE 4: INSULATION TAPE	11
4.5	FIGURE 5: MICA-DIELECTRIC CAPACITORS	12
4.6	FIGURE 6: DISCOIDAL CAPACITORS	12
4.7	FIGURE 7: TUBULAR CAPACITORS	13
4.8	FIGURE 8: ELECTRODE PLATES VISIBLE	13
4.9	FIGURE 9: HOLES, CHIPS AND CRACKS	13
4.10	FIGURE 10: END METALLISATION DEFECTS	14
4.11	FIGURE 11: END METALLISATION DEFECTS	14
4.12	FIGURE 12: GAPS BETWEEN LEAD AND CERAMIC SLUG	14
4.13	FIGURE 13: GAPS BETWEEN LEAD NAIL AND CERAMIC SLUG	15
4.14	FIGURE 14: SOLDER SPIKE	15
4.15	FIGURE 15: SOLDER SPIKE AND SHORT TERMINAL LENGTH	15
4.16	FIGURE 16: CRACKS OR NOTCHES IN THE BENDING AREA	16

1 **SCOPE**

This specification, to be read in conjunction with ESCC Basic Specification No. [20400](#), Internal Visual Inspection, contains additional specific requirements for Capacitors.

They shall apply to each component inspected.

2 **GENERAL REQUIREMENTS**

2.1 **APPLICABILITY**

The following criteria may not be varied or modified after commencing any inspection stage. Any ambiguity or proposed minor deviation shall be referred to the ESCC Executive for resolution and approval.

2.2 **PROCEDURE**

All components shall be submitted to examination immediately prior to sealing or encapsulation, or immediately after decapping, in an area where the standard of cleanliness is not less than that of the assembly area.

All items shall be examined in such a manner that a minimum of handling and movement of the component is involved. During handling of components, lint free gloves/finger cots shall be used.

2.3 **MAGNIFICATION**

All items shall be examined with a binocular or stereoscopic microscope under a magnification of x1 to x10.

2.4 **MOUNTING FIXTURES**

Suitable fixtures may be used to assist in the inspection process. They must not themselves cause damage to the device.

3 **DETAILED REQUIREMENTS**

3.1 **GENERAL**

A component shall be rejected if it exhibits one or more of the defects listed in any of the following paragraphs of this specification. Where applicable, drawings are included to provide additional explanatory material, but these shall be considered as examples only.

The lot inspected shall be homogeneous. A component shall therefore also be rejected if it exhibits a significant deviation, within the limits of this specification, from the rest of the lot. However, such components shall not be counted as a failure in any other lot definition.

3.2 TANTALUM CAPACITORS (SOLID/WET/CHIP)

3.2.1 Tantalum Pellet (See Figure 1 Para. 4.1)

- (a) No silver coat. (Solid electrolyte capacitors).
- (b) Silver coat over top of pellet shoulder or less than H/2. (Solid electrolyte capacitors).
- (c) Non-uniform colour of dielectric, which proves uneven thickness of that layer. (Wet electrolyte capacitors).

3.2.2 Termination (See Figure 2 Para. 4.2)

- (a) Inadequate weld of tantalum wire to terminal. There must be evidence of good mechanical bonding between the terminal and the tantalum lead. The decrease or increase in diameter due to the weld must not exceed D/4.
- (b) Bent tantalum wire on pellet - maximum deviation 5°.
- (c) The anode terminal shall be positioned and joined to the tantalum pellet such that there is evidence of good mechanical bonding and the dimensions of the unit will permit correct alignment of element in its mould/case.

3.3 PLASTIC-DIELECTRIC CAPACITORS

3.3.1 Termination Clearance (See Figure 3 Para. 4.3)

- (a) Contact metallisation does not cover 90% of the capacitor winding contact area (metallised turns of the winding only considered).
- (b) Sharp edges or overlapping on the contact metallisation that reduces termination clearance to less than 75% of original.
- (c) Top points of the contact metallisation higher than 0.5mm.

3.3.2 Terminal Leads

- (a) Corrosion evident.
- (b) Holes greater than 20% of the area covered by the terminal lead soldering.
- (c) Location of the terminal lead soldering not allowing for correct alignment of element in its mould/case.
- (d) Unattached solder globules.

3.3.3 Insulation (See Figure 4 Para. 4.4)

- (a) Edges of the contact area of the winding less than 100% covered by the insulation tape.
- (b) Insulation with cracks or holes.

3.3.4 Winding

- (a) Sheets overflowing beyond edge of winding.
- (b) Warped winding (telescoping).

3.4 MICA-DIELECTRIC CAPACITORS

3.4.1 Lead Conditions

- (a) Corrosion evident.
- (b) Cracks or notches in the bending area of the terminal leads.

3.4.2 Lead Welding

- (a) Width of the weld spot less than 70% of wire diameter.
- (b) Wire thickness reduced by welding by more than 10% of its original thickness.
- (c) Weld spot out of centre by more than 20% of the wire diameter or width.

3.4.3 Contact Area between Mica Plates (See Figure 5 Para. 4.5)

- (a) Cracks.
- (b) Disconnections.
- (c) Holes.

3.4.4 Mica Plates

- (a) Cracked or broken glass.
- (b) Chips in the plates that exceed 0.2mm in major dimension.
- (c) Misalignment of plates.

3.5 FILTER/FEED-THROUGH CAPACITORS (CERAMIC-DIELECTRIC)

3.5.1 Discoidal Capacitors (See Figure 6 Para. 4.6)

- (a) Cracks, buckling or delaminations in the ceramic dielectric.
- (b) Chips, voids or pin-holes in the ceramic dielectric that exceed 0.2mm in major dimension or penetrate to within 1 dielectric thickness of a buried electrode.
- (c) Discontinuity or lifting of metallisation.
- (d) Surface metallisation that reduces termination clearance to less than 75% of original radial distance between inner and outer termination.
- (e) Foreign matter or contamination.
- (f) Solder flux, balls, spikes, splashes or loose solder on pre-tinned components.

3.5.2 Tubular Capacitors (See Figure 7 Para. 4.7)

- (a) Cracks or buckling of the ceramic dielectric.
- (b) Chips, voids or pin-holes in the ceramic dielectric that exceed 0.2mm in major dimension or penetrate to within 1 dielectric thickness of a buried electrode.
- (c) Discontinuity or lifting of metallisation.
- (d) Surface metallisation that reduces termination clearance to less than 75% of original radial distance between inner and outer termination.
- (e) Foreign matter or contamination.
- (f) Solder flux, balls, spikes, splashes or loose solder on pre-tinned components.

3.5.3 Ferrite Sleeve (Inductive Element)

- (a) Cracked or broken ferrites.
- (b) Chips exceeding 10% of cross-sectional area.

3.5.4 Coils (Inductive Element)

- (a) Cracked, broken or chipped cores.
- (b) Kinks, bends or nicks in wire that reduce diameter by more than 10%.

3.5.5 Metal-plated Parts

- (a) Burrs, damaged threads or dents.
- (b) Discontinuity, flaking or discolouration of plating.

3.5.6 Sub-assembly or Pre-encapsulation Inspection

- (a) Excessive solder or metallic bridging between inner and outer capacitor electrode that reduces clearance to less than 75% of original radial distance between inner and outer termination.
- (b) Solder balls, spikes, splashes or loose solder.
- (c) Solder flux.
- (d) Defects in capacitor elements as defined in the Discoidal Capacitors and Tubular Capacitors paragraph.
- (e) Defects in inductive elements as defined in the Ferrite Sleeve and Coils paragraph.
- (f) Damage or defects in lead or body; damage or defects in plating of these elements.
- (g) Misalignment or eccentricity of sub-assembly elements.
- (h) Solder fillet of inner or outer capacitor terminations less than 75%.

3.6 CERAMIC-DIELECTRIC NON-FEED-THROUGH CAPACITORS

3.6.1 Ceramic Surface Defects (See Figures 8 and 9 Paras. 4.8 and 4.9)

- (a) Electrode plates visible.
- (b) Voids, pin-holes or chips in the ceramic dielectric that exceed 5% of the major dimension or 0.2mm, whichever is greater, or penetrate to within 1 effective dielectric thickness of a buried electrode.
- (c) Cracks, buckling, or delaminations in the ceramic dielectric.
- (d) Solder spots, conducting smear, flux and/or foreign material.

3.6.2 End Metallisation Defects (See Figures 10 and 11 Paras. 4.10 and 4.11)

- (a) End metallisation spikes: Distance A exceeds dimension E by more than 0.2mm.
- (b) Pad separation: Distance B exceeds dimension C so that the pad separation is reduced by more than 25%.
- (c) Voids in the end metallisation where distance D is larger than 25% of dimension C.
- (d) Holes and cracks in the end metallisation which fail the criterion of (c), or are larger than 0.2mm in major dimension.
- (e) Evidence of poor bonding between the end metallisation and the plates.
- (f) Evidence of poor bonding between the end metallisation and the leads.
- (g) For tinned types, the end metallisation shall cover at least 75% of the total surface to be metallised. The remaining 25% of the surface may contain pinholes or rough spots smaller than 0.2mm in major dimension, but these shall not be concentrated in one area.

3.6.3 Terminal Lead Defects (See Figures 12 to 16 Paras. 4.12 to 4.16)

- (a) Gaps between lead and ceramic slug larger than 20% of soldering interface A.
- (b) Gaps larger than 20% of the lead nail head diameter B.
- (c) Solder spikes exceeding ceramic slug by more than 0.2mm.
- (d) Contact length K between terminal lead and ceramic slug less than 75% of the body length C.
- (e) Cracks or notches in the bending area of terminal leads.
- (f) Corrosion evident.

4 FIGURES

4.1 FIGURE 1: TANTALUM PELLET

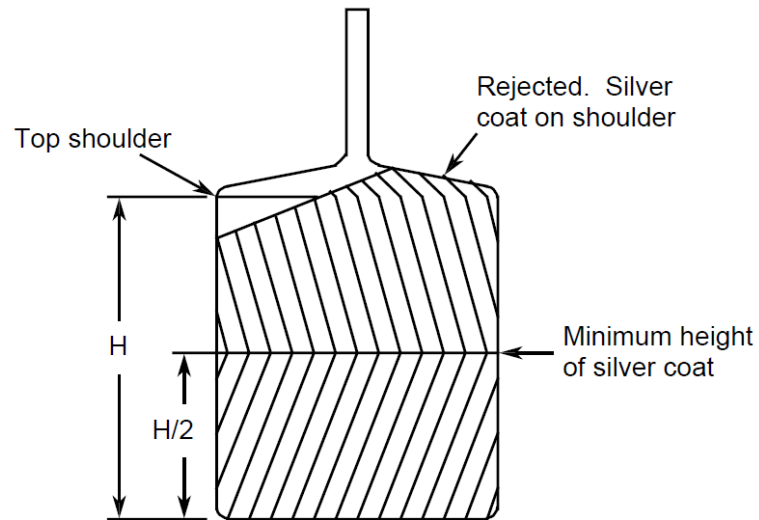

4.2 FIGURE 2: TERMINATION

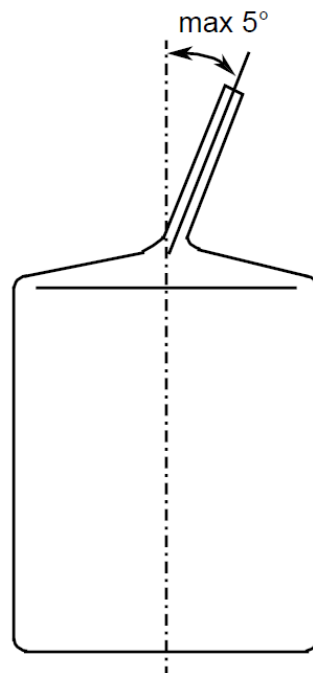

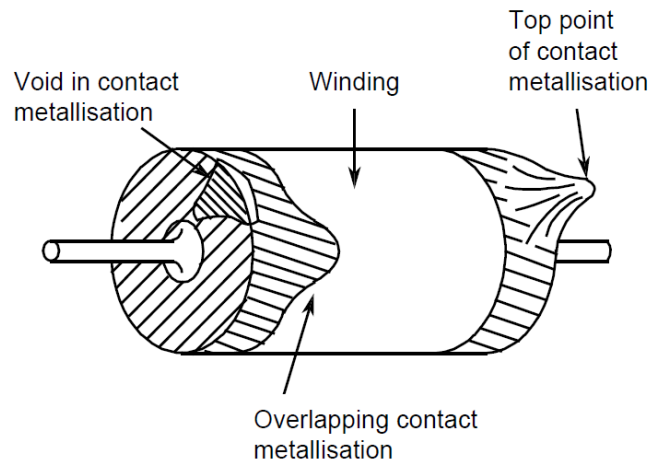
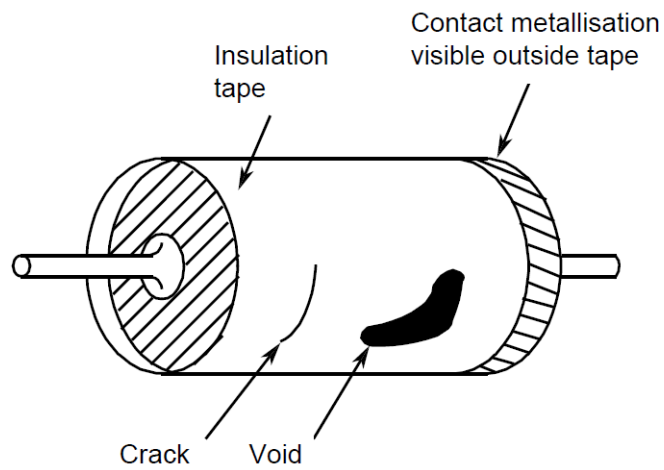
4.3 FIGURE 3: TERMINATION CLEARANCE4.4 FIGURE 4: INSULATION TAPE

4.5 FIGURE 5: MICA-DIELECTRIC CAPACITORS

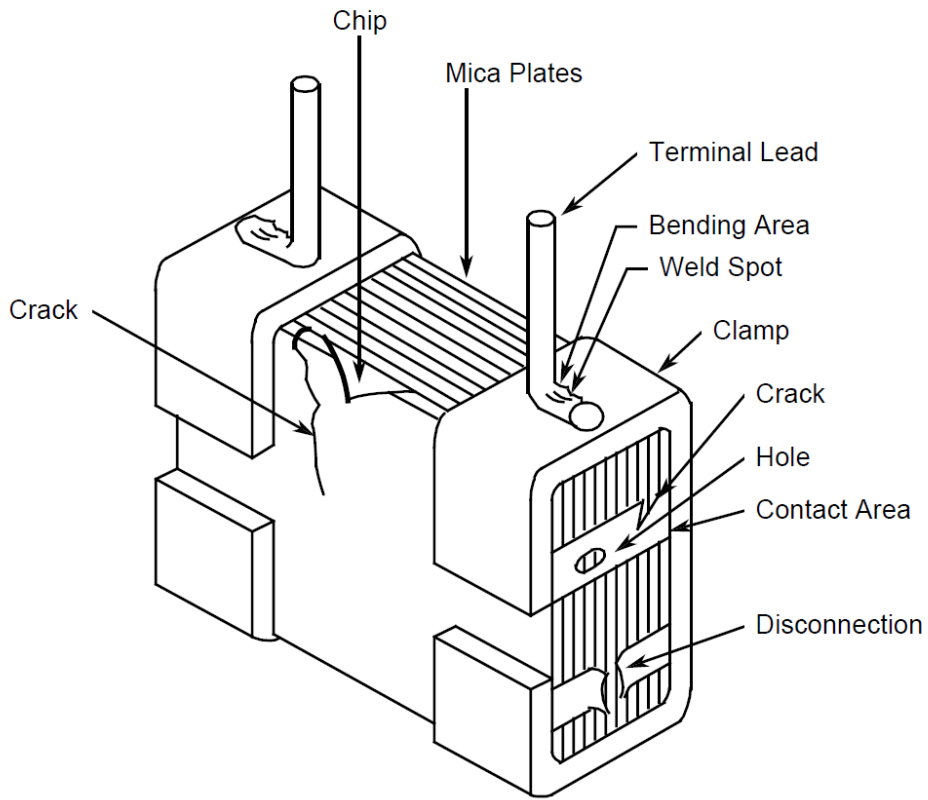

4.6 FIGURE 6: DISCOIDAL CAPACITORS

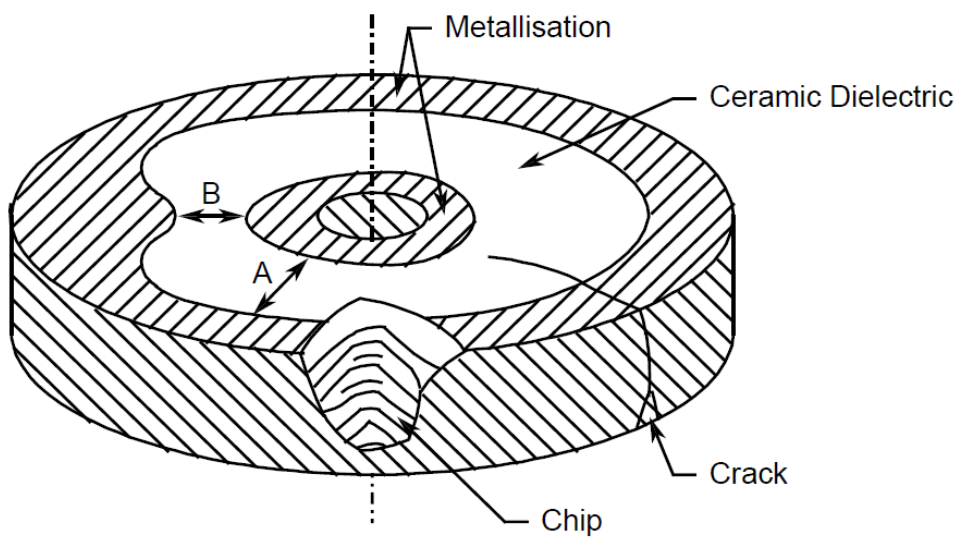

4.7 FIGURE 7: TUBULAR CAPACITORS

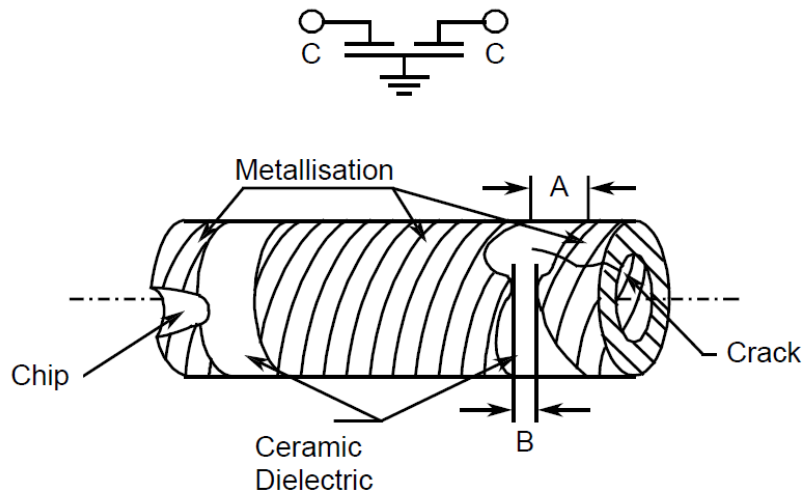

4.8 FIGURE 8: ELECTRODE PLATES VISIBLE

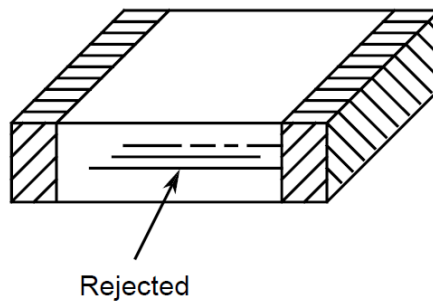

4.9 FIGURE 9: HOLES, CHIPS AND CRACKS

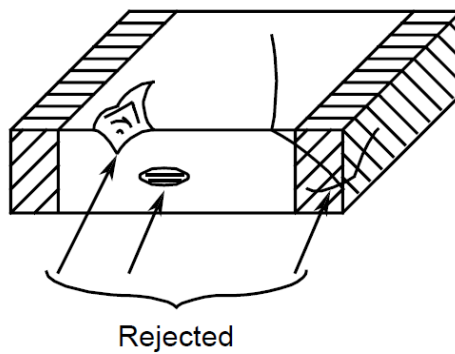

4.10 FIGURE 10: END METALLISATION DEFECTS

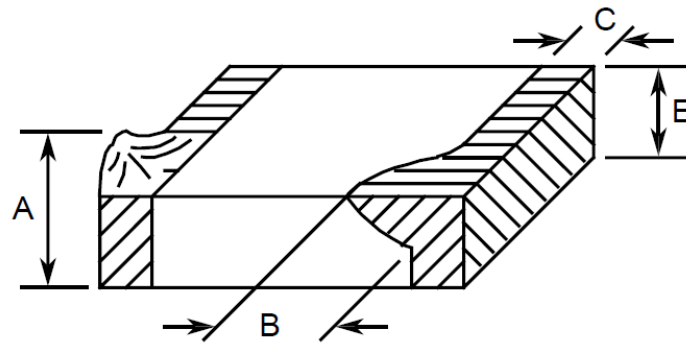

4.11 FIGURE 11: END METALLISATION DEFECTS

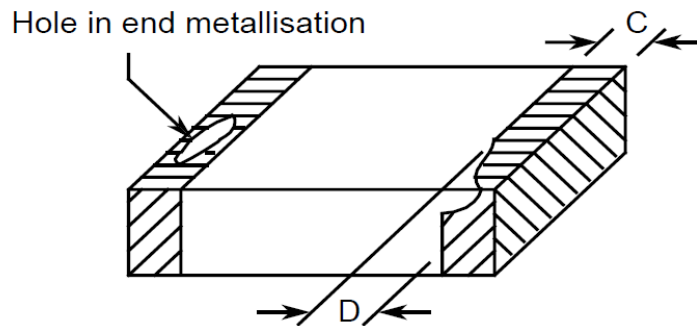

4.12 FIGURE 12: GAPS BETWEEN LEAD AND CERAMIC SLUG

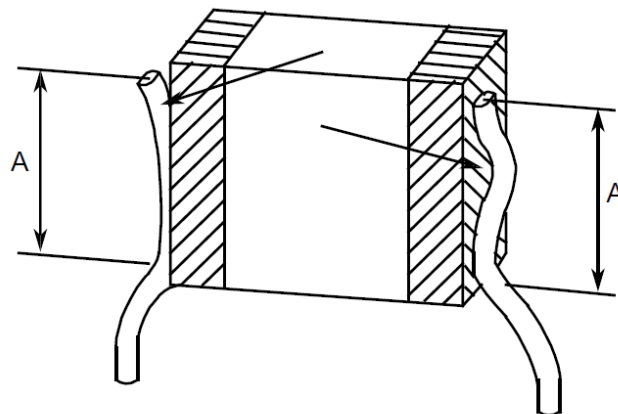

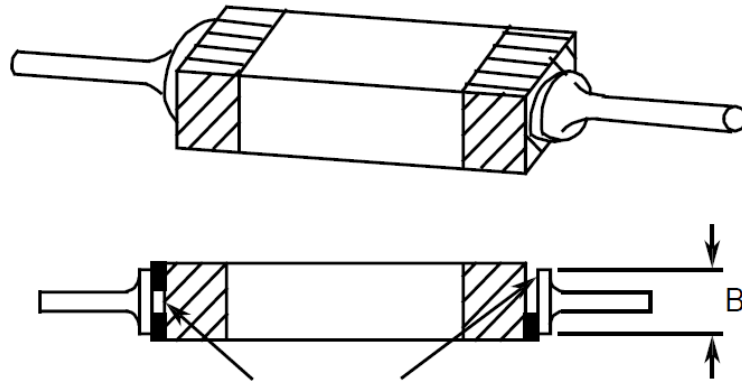
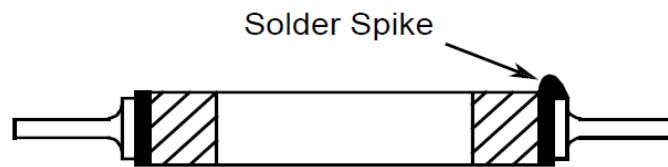
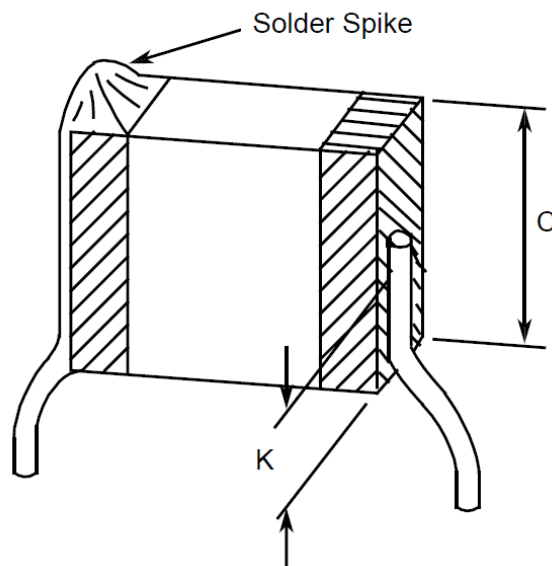
4.13 FIGURE 13: GAPS BETWEEN LEAD NAIL AND CERAMIC SLUG4.14 FIGURE 14: SOLDER SPIKE4.15 FIGURE 15: SOLDER SPIKE AND SHORT TERMINAL LENGTH

4.16 FIGURE 16: CRACKS OR NOTCHES IN THE BENDING AREA

