



EXTERNAL VISUAL INSPECTION OF CAPACITORS

ESCC Basic Specification No. 2053000

Issue 3	February 2014
---------	---------------



Document Custodian: European Space Agency – see <https://escies.org>

LEGAL DISCLAIMER AND COPYRIGHT

European Space Agency, Copyright © 2014. All rights reserved.

The European Space Agency disclaims any liability or responsibility, to any person or entity, with respect to any loss or damage caused, or alleged to be caused, directly or indirectly by the use and application of this ESCC publication.

This publication, without the prior permission of the European Space Agency and provided that it is not used for a commercial purpose, may be:

- copied in whole, in any medium, without alteration or modification.
- copied in part, in any medium, provided that the ESCC document identification, comprising the ESCC symbol, document number and document issue, is removed.

DOCUMENTATION CHANGE NOTICE

(Refer to <https://escies.org> for ESCC DCR content)

DCR No.	CHANGE DESCRIPTION
838	Specification upissued to incorporate editorial changes per DCR.

TABLE OF CONTENTS

1	SCOPE	6
2	GENERAL REQUIREMENTS	6
2.1	APPLICABILITY	6
2.2	PROCEDURE	6
2.3	MAGNIFICATION	6
2.4	MOUNTING FIXTURES	6
3	DETAILED REQUIREMENTS	6
3.1	DIMENSIONS AND MARKING	7
3.2	MATERIALS	7
3.3	CAPACITORS ENCAPSULATED IN HERMETIC TUBULAR CASES	7
3.3.1	Lead Condition	7
3.3.2	Lead Configuration (See Figures 2 to 5)	7
3.3.3	Case Sealing and Eyelet Solder Condition (See Figures 6 and 7) (When applicable)	8
3.3.4	Glass Seals	8
3.3.5	Can	8
3.4	SURFACE MOUNTED CAPACITORS	8
3.4.1	Terminal Condition (See Figure 8)	8
3.4.2	Terminal Configuration (See Figures 9 and 10)	8
3.4.3	Body Coating or Moulding	8
3.5	LEADED EPOXY-MOULDED OR COATED CAPACITORS	9
3.5.1	Lead Condition	9
3.5.2	Lead Configuration (See Figures 11 to 14)	9
3.5.3	Body Coating or Moulding	9
3.5.4	Epoxy Seals (When Applicable)	9
3.6	GLASS-DIELECTRIC CAPACITORS	9
3.6.1	Lead Condition	9
3.6.2	Lead Welding	9
3.6.3	Capacitor Plates	10
3.6.4	Glass Plates	10
4	FIGURES	10
4.1	FIGURE 1: TWISTED LEAD	10
4.2	FIGURE 2: KINKED LEAD	10
4.3	FIGURE 3: LEAD DEVIATING FROM SPECIFIED DIRECTION	10
4.4	FIGURE 4: ECCENTRICITY OF LEAD	11
4.5	FIGURE 5: TILTED LEAD	11

4.6	FIGURE 6: COCKED SEALING AREA	12
4.7	FIGURE 7: DEFECTS IN EYELET SOLDERING	12
4.8	FIGURE 8: NON-CONDUCTIVE MATERIAL ON TERMINALS	13
4.9	FIGURE 9: TERMINALS PROJECTING FROM BODY	13
4.10	FIGURE 10: KINKED TERMINAL	13
4.11	FIGURE 11: TWISTED STRAIGHT ROUND LEAD	14
4.12	FIGURE 12: KINKED OR BENT LEAD	14
4.13	FIGURE 13: LEAD DEVIATION FROM SPECIFIED DIRECTION	15
4.14	FIGURE 14: TILTED LEAD	15

1 **SCOPE**

This specification, to be read in conjunction with ESCC Basic Specification No. [20500](#), External Visual Inspection, contains additional specific requirements for Capacitors.

They shall apply to each component inspected.

2 **GENERAL REQUIREMENTS**

2.1 **APPLICABILITY**

The following criteria may not be varied or modified after commencing any inspection stage. Any ambiguity or proposed minor deviation shall be referred to the ESCC Executive for resolution and approval.

2.2 **PROCEDURE**

All items shall be examined in such a manner that a minimum of handling and movement of the component is involved. During handling of components, lint free gloves/finger cots shall be used.

2.3 **MAGNIFICATION**

All items shall be examined with a binocular or stereoscopic microscope under a magnification of 1x to 10x.

2.4 **MOUNTING FIXTURES**

Suitable fixtures may be used to assist in the inspection process. They must not themselves cause damage to the device.

3 **DETAILED REQUIREMENTS**

A component shall be rejected if it exhibits one or more of the defects listed in any of the following paragraphs of this specification. Where applicable, drawings are included to provide additional explanatory material, but these shall be considered as examples only.

The lot inspected shall be homogeneous. A component shall therefore also be rejected if it exhibits a significant deviation within the limits of this specification, from the rest of the lot. However, such components shall not be counted as a failure in any other lot definition.

The external visual inspection includes the verification of:

- Dimensions.
- Marking.
- Materials.
- Mechanical defects.

3.1 DIMENSIONS AND MARKING

Dimensions and marking shall be inspected in accordance with the requirements of ESCC Basic Specification No. 20500.

All letters and numbers shall be clearly legible without the use of optical resources.

Dimensional tolerances, including those of pin diameter and pin spacing, shall be as specified in the relevant ESCC Detail Specification.

3.2 MATERIALS

The materials used shall be verified for conformance to the requirements of the applicable ESCC Detail Specification. The production records shall be checked to ensure that the specific material requirements are met.

3.3 CAPACITORS ENCAPSULATED IN HERMETIC TUBULAR CASES

Such as:

- Solid electrolyte tantalum and aluminium capacitors.
- Plastic-dielectric capacitors.
- Filters and feed-through capacitors.

3.3.1 Lead Condition

- (a) Corrosion is evident.
- (b) Exposed base material, in excess of the lead diameter or thickness, caused by chipped glass meniscus.
- (c) Exposed base material anywhere on the lead within a distance of 20mm of the case, other than that caused by (b).
- (d) Exposed base material in excess of 5% of the surface area anywhere on the lead, beyond a distance of 1.5mm from the case.
- (e) Non-conductive material on the lead beyond a distance of 1.5mm from the case.
- (f) Reduction of lead diameter, width or thickness by more than 10%, within 20mm of the case.
- (g) Nicks, fractures, non-uniformity or discolouration of coating or abrasions exposing base material.

3.3.2 Lead Configuration (See Figures 2 to 5, Paras. 4.2 to 4.5)

- (a) Straight round leads twisted more than 1 revolution per 30mm of length.
- (b) Flat leads twisted more than 10° per any 10mm.
- (c) Leads kinked or bent and re-bent within 20mm of the case, other than for design, so that distance A as in Figure 2 Para. 4.2 is more than 2mm.
- (d) Leads deviating from the specified direction, by a straight line or by a soft bend, by more than 1mm per any 5mm of length.
- (e) Eccentricity of lead passing through header greater than 10% of the hole diameter, see ratio a/A in Figure 4 Para.4.4 .
- (f) Lead tilted by more than 5°.
- (g) Weld cathode terminal-to-case must be visible around the entire lead diameter. (When applicable.)
- (h) Defective cathode terminal-to-case weld. Burnt weld, weld flash, excessive deformation of lead or can is not accepted. (When applicable).

- 3.3.3 Case Sealing and Eyelet Solder Condition (See Figures 6 and 7 Paras 4.6, 4.7) (When applicable)
- Holes or lack of uniformity or continuity of solder around the complete perimeter of the case.
 - Solder protruding beyond the edge of the case.
 - Weld spatters, lack of uniformity or continuity of weld.
 - Reduction of design sealing area by more than 30% due to undercutting of sealing material or misalignment of case parts.
 - Glass cover tilted more than acceptable.
 - Holes or cracks in the eyelet soldering.
 - Solder protruding beyond the edge of the eyelet or longer than 0.5mm.
- 3.3.4 Glass Seals
- Filling protruding above the level of the case flange.
 - Bubbles in the seal whose diameter exceeds 12.5% of the seal diameter, or a collection of smaller bubbles which cannot be separated from each other or whose spatial distribution cannot be determined.
 - Foreign material embedded in the glass.
 - Chips or cracks of any length, shape or position except meniscus crazing.
- 3.3.5 Can
- Drops of solder on the can.
 - Any deformation of the can.
 - Corrosion or discolouration of the can.
- 3.4 SURFACE MOUNTED CAPACITORS
Such as:
- Solid electrolytic tantalum and aluminium chip capacitors. (For Ceramic-dielectric Chip Capacitors, see ESCC Basic Specification No. [2043000](#), Internal Visual Inspection of Fixed Capacitors).
- 3.4.1 Terminal Condition (See Figure 8 Para. 4.8)
- Corrosion is evident.
 - Exposed base material.
 - Non-conductive material on the terminals beyond H/2 of tab from the body moulding/termination interface.
 - Reduction of tab width or thickness by more than 10%.
- 3.4.2 Terminal Configuration (See Figures 9 and 10, Paras. 4.9 & 4.10)
- Terminals twisted more than 5°.
 - Terminal bends around the body moulding are not the nominal 90°.
 - Terminals projecting from body.
 - Terminals kinked or bent and re-bent, other than for design, so that distance A in Figure 10 Para. 4.10 is more than 1mm.
- 3.4.3 Body Coating or Moulding
- Any holes, voids or cracks visible at a magnification of maximum 10°.
 - Device body or body lead connections not covered by coating or moulding.
 - Chipping of coating or moulding when the chipped area exceeds 5% of the affected case side.
 - Embedded foreign material.
 - Discolouration of coating or moulding.

3.5 LEADED EPOXY-MOULDED OR COATED CAPACITORS

Such as:

- Ceramic-dielectric capacitors.
- Mica-dielectric capacitors.
- Plastic-dielectric capacitors.

3.5.1 Lead Condition

- (a) Corrosion is evident.
- (b) Exposed base material, in excess of the lead diameter or thickness, caused by chipped body moulding.
- (c) Exposed base material anywhere on the lead within a distance of 20mm of the moulding/termination interface, other than that caused by (b).
- (d) Exposed base material in excess of 5% of the surface area anywhere on the lead, beyond a distance of 20mm from the moulding/termination interface.
- (e) Non-conductive material on the lead beyond a distance of 1.5mm from the case.
- (f) Reduction of lead diameter, width or thickness by more than 10%, within 20mm of the case.
- (g) Nicks, fractures, non-uniformity or discolouration of coating or abrasions exposing base material.

3.5.2 Lead Configuration (See Figures 11 to 14, Paras. 4.11, 4.12, 4.13, 4.14)

- (a) Straight round leads twisted more than 1 revolution per 30mm of length
- (b) Flat leads twisted more than 10° per any 10mm.
- (c) Leads kinked or bent and re-bent within 20mm of the case, other than for design, so that distance "A" as in Figure 7 Para. 4.7 is more than 2mm.
- (d) Leads deviating from the specified direction, by a straight line or by a soft bend, by more than 1mm per any 5mm of length.
- (e) Lead tilted by more than 5°.

3.5.3 Body Coating or Moulding

- (a) Any holes, voids or cracks visible at a magnification of maximum 10x.
- (b) Device body or body lead connections not covered by coating or moulding.
- (c) Chipping of coating or moulding when the chipped area exceeds 5% of the affected case side.
- (d) Embedded foreign material.
- (e) Discolouration of coating or moulding.

3.5.4 Epoxy Seals (When Applicable)

- (a) Unevenness in meniscus of epoxy.
- (b) Spillage of epoxy on body.
- (c) Cracks, chips or evidence of bubbles in the epoxy.
- (d) Discolouration of foreign material in the epoxy.

3.6 GLASS-DIELECTRIC CAPACITORS

3.6.1 Lead Condition

- (a) Corrosion evident.

3.6.2 Lead Welding

- (a) Width of the weld spot less than 70% of wire diameter.
- (b) Weld spot out of centre by more than 20% of the wire diameter or width.
- (c) There must be evidence of good mechanical bonding between wire and capacitor's plates.

3.6.3 Capacitor Plates

- (a) Cracks or holes that exceed 0.2mm in major dimension.
- (b) Disconnections.
- (c) Corrosion.

3.6.4 Glass Plates

- (a) Capacitor Plates extending beyond glass plates.
- (b) Voids, pin-holes or chips in the glass that exceed 0.2mm in major dimension.
- (c) Any crack that exceeds 0.2mm in length.

4 **FIGURES**

4.1 FIGURE 1: TWISTED LEAD

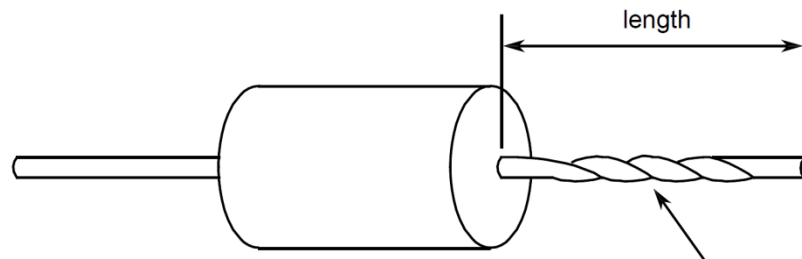

4.2 FIGURE 2: KINKED LEAD

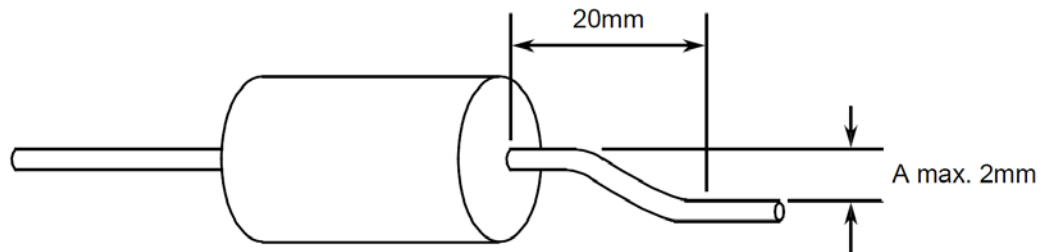

NOTES:

- (a) Bent and re-bent lead. Rejected if A is more than 2mm within 20mm of case.

4.3 FIGURE 3: LEAD DEVIATING FROM SPECIFIED DIRECTION

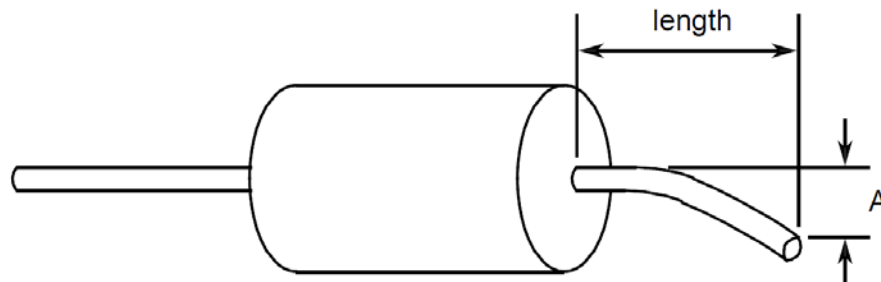

NOTES:

- (a) Rejected if A is more than 1mm per 5mm of length.

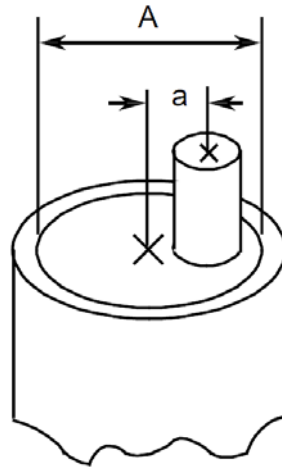
4.4 FIGURE 4: ECCENTRICITY OF LEAD**NOTES:**

(a) Rejected if a is more than 10% of A .

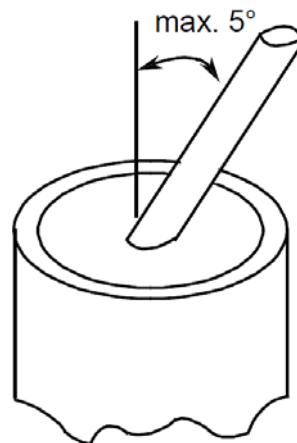
4.5 FIGURE 5: TILTED LEAD

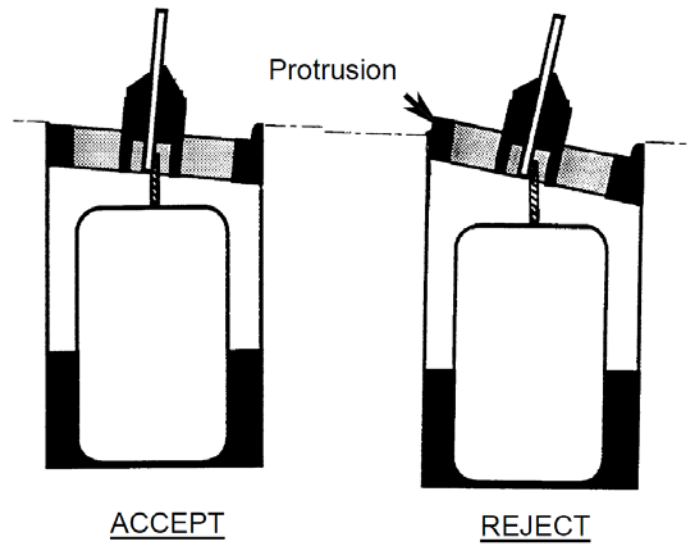
4.6 FIGURE 6: COCKED SEALING AREA**NOTES:**

(a) The glass cover shall not protrude beyond the end of the case.

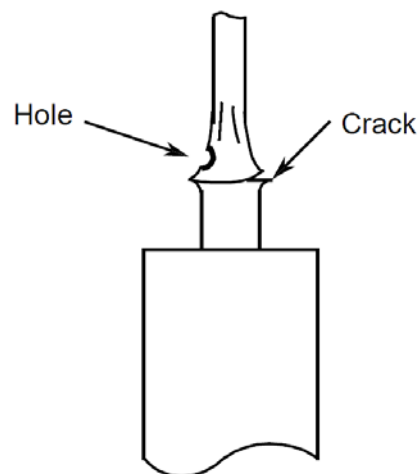
4.7 FIGURE 7: DEFECTS IN EYELET SOLDERING**NOTES:**

(a) Rejected if holes or cracks are visible.

4.8 FIGURE 8: NON-CONDUCTIVE MATERIAL ON TERMINALS

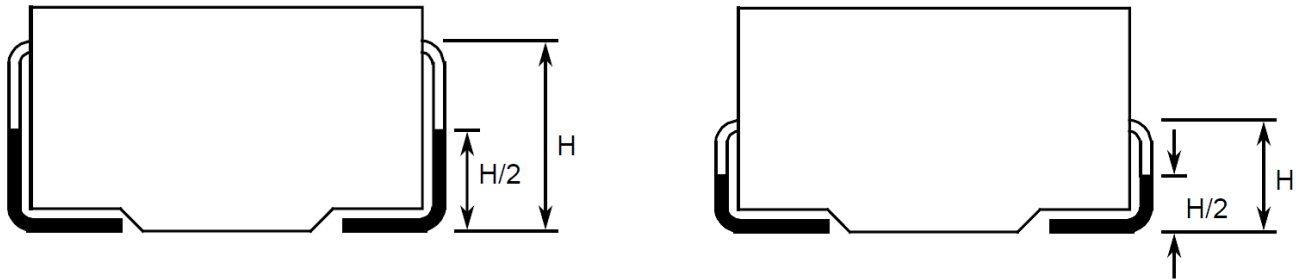

NOTES:

(a) Rejected if non-conductive material on marked parts of terminals (H/2).

4.9 FIGURE 9: TERMINALS PROJECTING FROM BODY

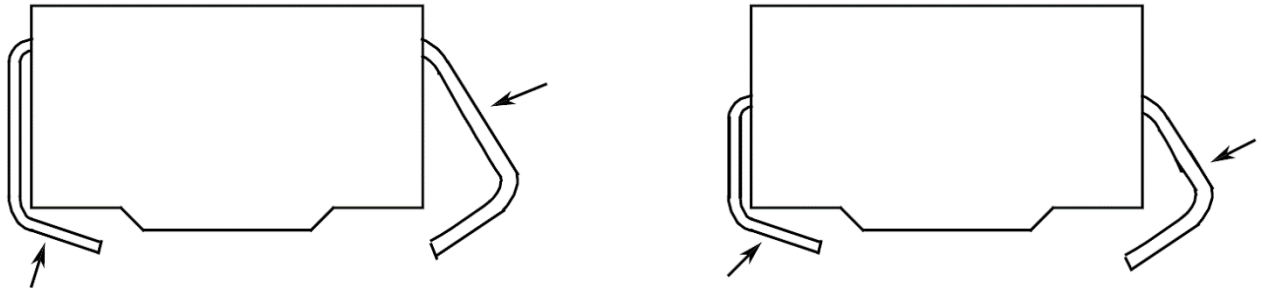

NOTES:

(a) Rejected if terminals projecting from body.

4.10 FIGURE 10: KINKED TERMINAL

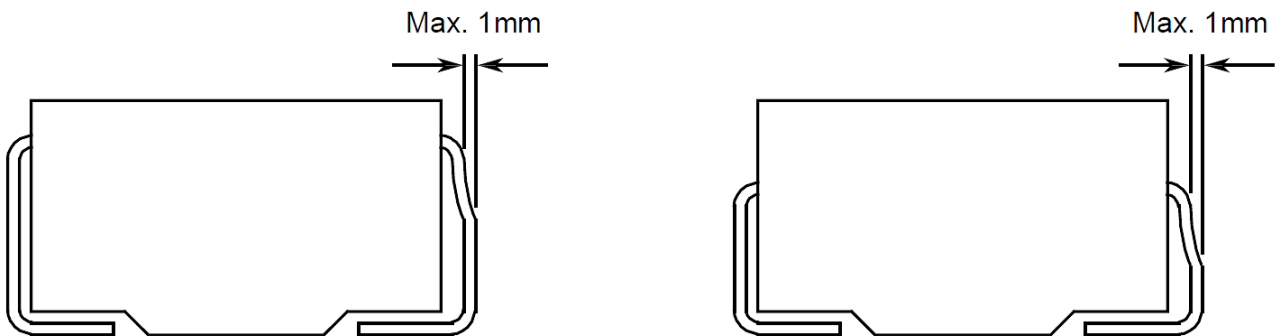

NOTES:

(a) Rejected if marked distance is more than 1mm.

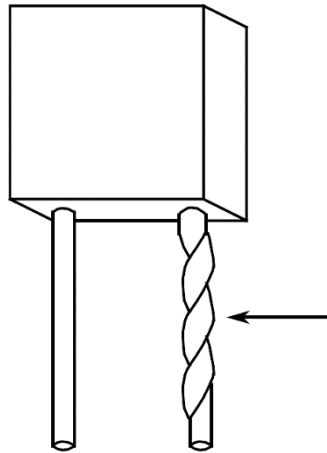
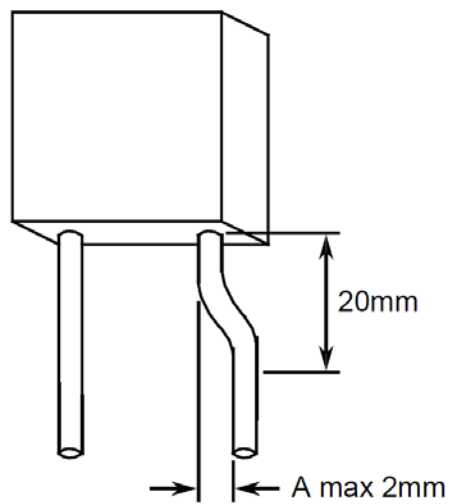
4.11 FIGURE 11: TWISTED STRAIGHT ROUND LEAD4.12 FIGURE 12: KINKED OR BENT LEAD**NOTES:**

(a) Bent and re-bent lead. Rejected if A is more than 2mm within 20mm of case.

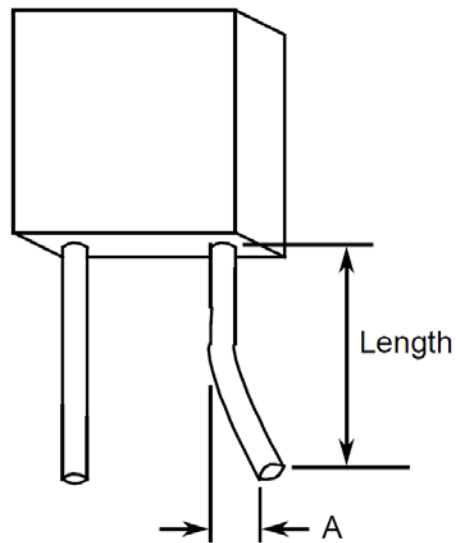
4.13 FIGURE 13: LEAD DEVIATION FROM SPECIFIED DIRECTION**NOTES:**

(a) Rejected if A is more than 1mm per 5mm of length.

4.14 FIGURE 14: TILTED LEAD