



**CAPACITORS, LEADLESS SURFACE MOUNTED,  
TANTALUM, SOLID ELECTROLYTE, ENCLOSED  
ANODE CONNECTION,  
BASED ON TYPE TAJ**

**ESCC Detail Specification No. 3012/001**

Issue 4	April 2014
---------	------------



### **LEGAL DISCLAIMER AND COPYRIGHT**

European Space Agency, Copyright © 2014. All rights reserved.

The European Space Agency disclaims any liability or responsibility, to any person or entity, with respect to any loss or damage caused, or alleged to be caused, directly or indirectly by the use and application of this ESCC publication.

This publication, without the prior permission of the European Space Agency and provided that it is not used for a commercial purpose, may be:

- copied in whole, in any medium, without alteration or modification.
- copied in part, in any medium, provided that the ESCC document identification, comprising the ESCC symbol, document number and document issue, is removed.

**DOCUMENTATION CHANGE NOTICE**

(Refer to <https://escies.org> for ESCC DCR content)

DCR No.	CHANGE DESCRIPTION
840	Specification upissued to incorporate technical changes per DCR.

**TABLE OF CONTENTS**

1	GENERAL	6
1.1	SCOPE	6
1.2	TYPE VARIANTS AND RANGE OF COMPONENTS	6
1.3	MAXIMUM RATINGS	6
1.4	PARAMETER DERATING INFORMATION	6
1.5	PHYSICAL DIMENSIONS	6
1.6	FUNCTIONAL DIAGRAM	6
2	APPLICABLE DOCUMENTS	10
3	TERMS, DEFINITIONS, ABBREVIATIONS, SYMBOLS AND UNITS	10
4	REQUIREMENTS	10
4.1	GENERAL	10
4.2	DEVIATIONS FROM GENERIC SPECIFICATION	10
4.2.1	Deviations from Special In-process Controls	10
4.2.2	Deviations from Final Production Tests (Chart II)	10
4.2.3	Deviations from Burn-in and Electrical Measurements (Chart III)	10
4.2.4	Deviations from Qualification Tests (Chart IV)	10
4.2.5	Deviations from Lot Acceptance Tests (Chart V)	10
4.3	MECHANICAL REQUIREMENTS	10
4.3.1	Dimension Check	10
4.3.2	Weight	11
4.4	MATERIALS AND FINISHES	11
4.4.1	Terminations	11
4.5	MARKING	11
4.5.1	General	11
4.5.2	The ESCC Component Number	11
4.5.3	Electrical Characteristics and Ratings	11
4.5.4	Traceability Information	12
4.6	ELECTRICAL MEASUREMENTS	12
4.6.1	Electrical Measurements at Room Temperature	12
4.6.2	Electrical Measurements at High and Low Temperatures	12
4.6.3	Circuits for Electrical Measurements	12
4.7	BURN-IN TESTS	13
4.7.1	Parameter Drift Values	13
4.7.2	Conditions for Burn-in	13
4.7.3	Electrical Circuits for Burn-in	13

4.8	ENVIRONMENTAL AND ENDURANCE TESTS (CHARTS IV AND V OF ESCC GENERIC SPECIFICATION NO. 3012)	15
4.8.1	Measurements and Inspections on Completion of Environmental Tests	15
4.8.2	Measurements and Inspections at Intermediate Points during Endurance Tests	15
4.8.3	Measurements and Inspections on Completion of Endurance Tests	15
4.8.4	Conditions for Operating Life Tests (Part of Endurance Testing)	15
4.8.5	Electrical Circuit for Operating Life Tests (Figure 5)	15
	APPENDIX 'A'	19

## 1 GENERAL

### 1.1 SCOPE

This specification details the ratings, physical and electrical characteristics, test and inspection data for Capacitors, Leadless Surface Mounted, Tantalum, Solid Electrolyte, Enclosed Anode Connection, based on Type TAJ.

It shall be read in conjunction with ESCC Generic Specification No. 3012, the requirements of which are supplemented herein.

### 1.2 TYPE VARIANTS AND RANGE OF COMPONENTS

Variants of the basic type capacitors and the range of components covered by this specification are scheduled in Figure 2 and Table 1(a) respectively.

### 1.3 MAXIMUM RATINGS

The maximum ratings, which shall not be exceeded at any time during use or storage, applicable to the capacitors specified herein, are as scheduled in Table 1(b).

### 1.4 PARAMETER DERATING INFORMATION

The parameter derating information applicable to the capacitors specified herein is shown in Figure 1.

### 1.5 PHYSICAL DIMENSIONS

The physical dimensions of the capacitors specified herein are shown in Figure 2.

### 1.6 FUNCTIONAL DIAGRAM

The functional diagram of the capacitors specified herein is shown in Figure 3.

**TABLE 1(a) - RANGE OF COMPONENTS**

CAP VALUE (μF) (2)	RATED VOLTAGE (V) (1)							
	4	6.3	10	16	20	25	35	50
0.1							A	A
0.15							A	B
0.22							A	B
0.33							A	B
0.47						A	A, B	C
0.68					A	A	A, B	C
1				A	A	A	B	C
1.5			A	A	A	B	B, C	D
2.2		A	A	A, B	B	B	B, C	D
3.3	A	A	A	A, B	B	B, C	C	D
4.7	A	A	A, B	B	B, C	C	C, D	D
6.8	A	A, B	B	B, C	C	C, D	D	D
10	A, B	B	B, C	C	C	C, D	D	E
15	B	B, C	C	C	C, D	D	D	
22	B, C	C	C	C, D	D	D	E	
33	C	C	C, D	D	D	E		
47	C, D	C, D	C, D	D	E			
68	C, D	D	D	D	E			
100	D	D	D	E				
150	D	D	E					
220	E	E	E					

**NOTES**

1. Letters indicate case sizes (See Figure 2).
2. Tolerances of ±10% and ±20% are available.

**TABLE 1(b) - MAXIMUM RATINGS**

No.	Characteristics	Symbol	Maximum Ratings		Units	Remarks
			Min	Max		
1	Rated Voltage	$U_R$	See Table 1(a)		Vdc	
2	Surge Voltage	$U_S$	-	$1.3 \times U_R$	Vdc	$\leq +85^\circ\text{C}$
3	Category Voltage	$U_C$	-	$0.66 \times U_R$	Vdc	
4	Operating Temperature Range	$T_{op}$	-55	+125	$^\circ\text{C}$	
5	Rated Temperature	$T_r$	-	+85	$^\circ\text{C}$	
6	Category Temperature	$T_c$	-	+125	$^\circ\text{C}$	
7	Storage Temperature Range	$T_{stg}$	-55	+125	$^\circ\text{C}$	
8	Soldering Temperature	$T_{sol}$	-	+260	$^\circ\text{C}$	Note 1

**NOTES**

1. Soldering time 5 seconds maximum for wave soldering and 10 seconds maximum for reflow soldering.

**FIGURE 1 - PARAMETER DERATING INFORMATION**

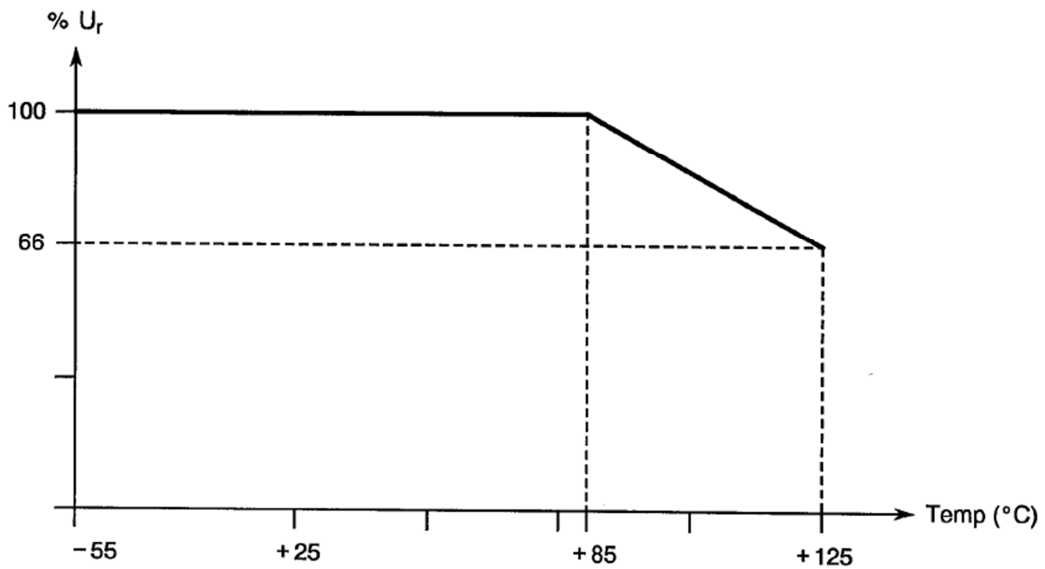

Voltage versus Temperature



**FIGURE 2 - PHYSICAL DIMENSIONS**

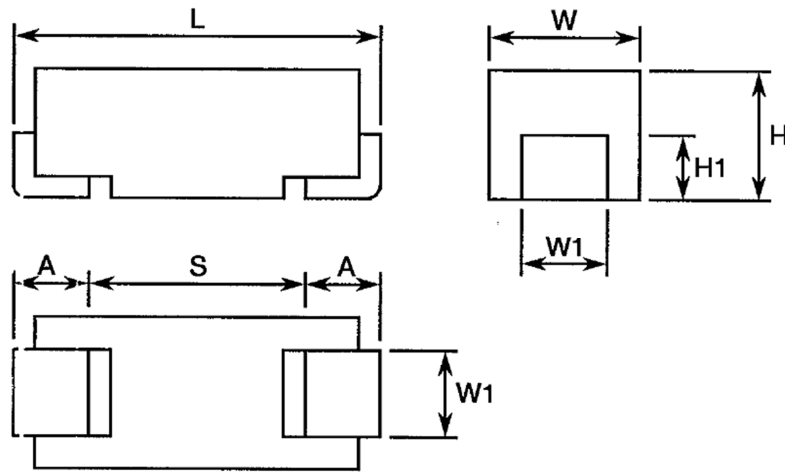

Variant (1)	Case Size	Dimensions (mm)										
		L		W		H	W1		A		S	H1
		Min	Max	Min	Max	Min	Max	Min	Max	Min	Max	Min
01	A	3	3.4	1.5	1.8	1.8	1.1	1.3	0.6	1.1	1.1	0.7
02	B	3.3	3.7	2.7	3	2.1	2.1	2.3	0.6	1.1	1.4	0.7
13	C	5.8	6.2	3.1	3.4	2.8	2.1	2.3	1.1	1.6	2.9	0.7
14	D	7.1	7.5	4.2	4.5	3.1	2.3	2.5	1.1	1.6	4.4	0.7
17	E	7.1	7.5	4.2	4.5	4.3	2.3	2.5	1.1	1.6	4.4	0.7

**NOTE:**

1. Variants 01 & 02 differ from Variants 13, 14 & 17 by their terminations (see Para. 4.4.1).

**FIGURE 3 - FUNCTIONAL DIAGRAM**

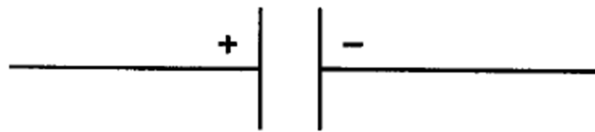

## 2 APPLICABLE DOCUMENTS

The following documents form part of this specification and shall be read in conjunction with it:

- (a) ESCC Generic Specification No. 3012 for Capacitors, Leadless Surface Mounted, Tantalum, Solid Electrolyte, Enclosed Anode Connection.

## 3 TERMS, DEFINITIONS, ABBREVIATIONS, SYMBOLS AND UNITS

For the purpose of this specification, the terms, definitions, abbreviations, symbols and units specified in ESCC Basic Specification No. 21300 shall apply.

## 4 REQUIREMENTS

### 4.1 GENERAL

The complete requirements for procurement of the components specified herein shall be as stated in this specification and ESCC Generic Specification No. 3012. Deviations from the Generic Specification, applicable to this Detail Specification only, are listed in Para. 4.2.

Deviations from the applicable Generic Specification and this Detail Specification, formally agreed with specific Manufacturers on the basis that the alternative requirements are equivalent to the ESCC requirements and do not affect the components' reliability, are listed in the appendices attached to this specification.

### 4.2 DEVIATIONS FROM GENERIC SPECIFICATION

#### 4.2.1 Deviations from Special In-process Controls

None.

#### 4.2.2 Deviations from Final Production Tests (Chart II)

None.

#### 4.2.3 Deviations from Burn-in and Electrical Measurements (Chart III)

None.

#### 4.2.4 Deviations from Qualification Tests (Chart IV)

- (a) Para. 9.19, Solderability: the solderable area is the termination 'pad' and up to 1/3 the height of the tab.

#### 4.2.5 Deviations from Lot Acceptance Tests (Chart V)

- (a) Para. 9.19, Solderability: the solderable area is the termination 'pad' and up to 1/3 the height of the tab.

### 4.3 MECHANICAL REQUIREMENTS

#### 4.3.1 Dimension Check

The dimensions of the components specified herein shall be verified in accordance with the requirements set out in Para. 9.6 of ESCC Generic Specification No. 3012. They shall conform to those shown in Figure 2 of this specification.

#### 4.3.2 Weight

The maximum weight of the capacitors specified herein shall be as follows:

- Case Size 'A' - 0.1 grammes
- Case Size 'B' - 0.2 grammes
- Case Size 'C' - 0.3 grammes
- Case Size 'D' - 0.5 grammes
- Case Size 'E' - 0.7 grammes

#### 4.4 MATERIALS AND FINISHES

The materials and finishes shall be as specified herein. Where a definite material is not specified, a material which will enable the components specified herein to meet the performance requirements of this specification shall be used. Acceptance or approval of any constituent material does not guarantee acceptance of the finished product.

##### 4.4.1 Terminations

For Variants 01 & 02: the termination shall be Type 'G' with Type '16' finish in accordance with the requirements of ESCC Basic Specification No. 23500.

For Variants 13, 14 & 17: the termination shall be Type 'P' with Type '17' finish in accordance with the requirements of ESCC Basic Specification No. 23500.

#### 4.5 MARKING

##### 4.5.1 General

The marking of all components delivered to this specification shall be in accordance with the requirements of ESCC Basic Specification No. 21700 and the following paragraphs. For those components too small to accommodate the marking as specified hereafter, the marking information in full shall accompany each component in its primary package. Such marking shall comprise:

- (a) The ESCC Component Number.
- (b) Characteristics and Ratings.
- (c) Traceability Information.

##### 4.5.2 The ESCC Component Number

Each component shall bear the ESCC Component Number which shall be constituted and marked as follows:

Example: 301200101B

- Detail Specification Number: 3012001
- Type Variant (as applicable, see Figure 2): 01
- Testing Level (B or C, as applicable): B

##### 4.5.3 Electrical Characteristics and Ratings

The electrical characteristics and ratings to be marked, in the following order of precedence, are:

- (a) Polarity.
- (b) Numerical value.
- (c) Rated voltage.
- (d) Tolerance.

4.5.3.1 *Polarity*

The anode connection shall be indicated by a BAR on the coded surface.

**NOTES:**

1. For qualified devices, the ESCC qualified components symbol may be used to indicate the anode connection.

4.5.3.2 *Capacitance*

This shall be indicated by the value marked on the component.

4.5.3.3 *Rated Voltage*

This shall be indicated by the value marked on the component or, where the body size is too small, by the code letters specified hereafter:

Rated Voltage (V)	Code Letter
4	G
6.3	J
10	A
16	C
20	D
25	E
35	V
50	T

4.5.3.4 *Tolerance*

The tolerance on numerical values shall be indicated by the code letters specified hereafter:

Tolerance	Code Letter
±10%	K
±20%	M

4.5.4 Traceability Information

Traceability information shall be marked in accordance with the requirements of ESCC Basic Specification No. 21700. The information to be marked shall be as follows:

- (a) Manufacturing date code.
- (b) Serial number.
- (c) Manufacturer's name.

4.6 ELECTRICAL MEASUREMENTS

4.6.1 Electrical Measurements at Room Temperature

The parameters to be measured in respect of electrical characteristics are scheduled in Table 2. The measurements shall be performed at  $T_{amb} = +22 \pm 3^{\circ}C$ .

4.6.2 Electrical Measurements at High and Low Temperatures

The parameters to be measured at high and low temperatures are scheduled in Table 3.

4.6.3 Circuits for Electrical Measurements

Not applicable.

4.7 BURN-IN TESTS

4.7.1 Parameter Drift Values

The parameter drift values applicable to burn-in are specified in Table 4 of this specification. Unless otherwise stated, measurements shall be performed at  $T_{amb} = +22 \pm 3^{\circ}C$ . The parameter drift values ( $\Delta$ ) applicable to the scheduled parameters shall not be exceeded. In addition to these drift value requirements for a given parameter, the appropriate limit value specified in Table 2 shall not be exceeded.

4.7.2 Conditions for Burn-in

The requirements for burn-in are specified in Section 7 of ESCC Generic Specification No. 3012. The conditions for burn-in shall be as specified in Table 5(a) of this specification.

4.7.3 Electrical Circuits for Burn-in

Not applicable.

**TABLE 2 - ELECTRICAL MEASUREMENTS AT ROOM TEMPERATURE**

No.	Characteristics	Symbol	Spec. and/or Test Method	Test Conditions	Limits		Unit
					Min	Max	
1	Capacitance	C	ESCC 3012 Para. 9.4.1.1		-10 -20	+10 +20	%
2	DC Leakage Current	$I_L$	ESCC 3012 Para. 9.4.1.2		-	$0.01 \times C \times U_R$ or (1) 1	$\mu A$
3	Dissipation Factor	DF	ESCC 3012 Para. 9.4.1.3	$U_R < 10V$	-	6	%
				$U_R \geq 10V, C \leq 1\mu F$	-	4	
				$U_R \geq 10V, C > 1\mu F$	-	6	

**NOTES**

1. Whichever is greater.

**TABLE 3 - ELECTRICAL MEASUREMENTS AT HIGH AND LOW TEMPERATURE**

No.	Characteristics	Symbol	Spec. and/or Test Method	Test Conditions (Note 2)	Limits		Unit
					Min	Max	
1	Capacitance Change	$\Delta C/C$	ESCC 3012 Para. 9.4.1.1	-55 (+3 -0) $^{\circ}C$ +85 $\pm 3^{\circ}C$ +125 (+0 -3) $^{\circ}C$	-8 0 0	0 +8 +12	%
2	DC Leakage Current	$I_L$	ESCC 3012 Para. 9.4.1.2	+85 $\pm 3^{\circ}C$	-	$0.1 \times C \times U_R$ or (1) 1	$\mu A$
				+125 (+0 -3) $^{\circ}C$	-	$0.125 \times C \times U_R$ or (1) 1 (3)	
3	Dissipation Factor	DF	ESCC 3012 Para. 9.4.1.3	-55 (+3 -0) $^{\circ}C$	-	9	%
				+85 $\pm 3^{\circ}C$	-	7.2	
				+125 (+0 -3) $^{\circ}C$	-	9	

**NOTES**

1. Whichever is greater.
2. Inspection level II single sampling, AQL 2.5% for each capacitance value. Each capacitance value shall be considered as constituting a complete lot.
3. Measured with category voltage.

**FIGURE 4 – CIRCUITS FOR ELECTRICAL MEASUREMENTS**

Not applicable

**TABLE 4 - PARAMETER DRIFT VALUES**

No.	Characteristics	Symbol	Spec. and/or Test Method	Test Conditions	Limits	Unit
1	Capacitance Change	$\Delta C/C$	As per Table 2	As per Table 2	$\pm 5$	%
2	DC Leakage Current Change	$\Delta I_L$	As per Table 2	As per Table 2	2 x Initial Value (1) or (2) (0.25 x Table 2 Item 2) +0.05 $\mu$ A	$\mu$ A

**NOTES**

1. Leakage currents  $\leq 0.1\mu$ A are considered as a 0.1 $\mu$ A value.
2. Whichever is smaller.

**TABLE 5(a) - CONDITIONS FOR BURN-IN**

No.	Characteristics	Symbol	Conditions	Unit
1	Ambient Temperature	$T_{amb}$	+85 (+0 -3)	$^{\circ}$ C
2	Test Voltage	$V_T$	$U_R$	V

**TABLE 5(b) - CONDITIONS FOR OPERATING LIFE TESTS**

No.	Characteristics	Symbol	Conditions	Unit
1	Ambient Temperature 1	$T_{amb1}$	+85 (+0 -3)	$^{\circ}$ C
2	Test Voltage 1	$V_{T1}$	$U_R$	V
3	Ambient Temperature 2	$T_{amb2}$	+125 (+0 -3)	$^{\circ}$ C
4	Test Voltage 2	$V_{T2}$	$U_C$	V

**FIGURE 5 - ELECTRICAL CIRCUIT FOR BURN-IN AND OPERATING LIFE TEST**

Not applicable.

- 4.8 ENVIRONMENTAL AND ENDURANCE TESTS (CHARTS IV AND V OF ESCC GENERIC SPECIFICATION No. 3012)
- 4.8.1 Measurements and Inspections on Completion of Environmental Tests  
The parameters to be measured and inspections to be performed on completion of environmental tests are scheduled in Table 6. Unless otherwise stated, the measurements shall be performed at  $T_{amb} = +22 \pm 3^{\circ}\text{C}$ .
- 4.8.2 Measurements and Inspections at Intermediate Points during Endurance Tests  
The parameters to be measured and inspections to be performed at intermediate points during endurance tests are scheduled in Table 6. The measurements shall be performed at the temperatures specified for the test.
- 4.8.3 Measurements and Inspections on Completion of Endurance Tests  
The parameters to be measured and inspections to be performed on completion of endurance tests are scheduled in Table 6. Unless otherwise stated, the measurements shall be performed at  $T_{amb} = +22 \pm 3^{\circ}\text{C}$ .
- 4.8.4 Conditions for Operating Life Tests (Part of Endurance Testing)  
The requirements for operating life testing are specified in Section 9 of ESCC Generic Specification No. 3012. The conditions for operating life testing shall be as specified in Table 5(b) of this specification.
- 4.8.5 Electrical Circuit for Operating Life Tests (Figure 5)  
Not applicable.

**TABLE 6 - MEASUREMENTS AND INSPECTIONS ON COMPLETION OF ENVIRONMENTAL TESTS AND AT INTERMEDIATE POINTS AND ON COMPLETION OF ENDURANCE TESTING**

No.	ESCC Generic Spec. No. 3012		Measurements and Inspections		Symbols	Limits		Units
	Environmental and Endurance Tests (Note 1)	Test Methods and Conditions	Identification	Conditions		Min	Max	
01	Mounting	Para. 9.9	<b>Final Examination</b> Terminals	Good tinning	-	-	-	
			<b>Final Measurements</b> Capacitance	Table 2 Item 1	C	Record Values		
			DC Leakage Current	Table 2 Item 2	I <sub>L</sub>	-	Table 2	
			Dissipation Factor	Table 2 Item 3	DF	-	Table 2	
02	Rapid Change of Temperature	Para. 9.3.2	<b>Initial Measurements</b> Capacitance	Value recorded in 01	C	Table 2 Item 1		
			<b>Final Measurements</b> Visual Examination	Recovery period of 4 hours min. -	-	-	-	
			Capacitance Change	Table 2 Item 1	ΔC/C	-5	+5	%
			DC Leakage Current	Table 2 Item 2	I <sub>L</sub>	-	Table 2	
			Dissipation Factor	Table 2 Item 3	DF	-	Table 2	
03	External Visual Inspection	Para. 9.5	<b>Final Inspection</b> Visual Inspection	ESCC No. 20500	-	-	-	
04	Adhesion	Para. 9.10	<b>Initial Measurements</b> Capacitance	Value recorded in 01	C	Table 2 Item 1		
			<b>Final Measurements</b> Visual Examination	No damage or loosening from the substrate	-	-	-	
			Capacitance Change	Table 2 Item 1	ΔC/C	-5	+5	%
05	Vibration	Para. 9.11	<b>Measurements during test</b>	During Last Cycle				
				No intermittent Contact >0.5ms, arcing or open or shorts	-	-	-	
			<b>Final Examination</b> Visual Examination	No damage	-	-	-	
06	Shock or Bump	Para. 9.12	<b>Final Examination</b> Visual Examination	No damage	-	-	-	



No.	ESCC Generic Spec. No. 3012		Measurements and Inspections		Symbols	Limits		Units	
	Environmental and Endurance Tests (Note 1)	Test Methods and Conditions	Identification	Conditions		Min	Max		
07	Climatic Sequence	Para. 9.13	<b>Initial Measurements</b>	Value recorded in 01	C	Table 2 Item 1			
			Capacitance	After Dry Heat (2)					
			<b>Intermediate Measurements</b>	Table 3 Item 2	I <sub>L</sub>	-	Table 3		
			DC Leakage Current	After recovery of 1 to 24 hours					
			<b>Final Measurements</b>	ESCC No. 20500	-	-	-		
			Visual Inspection	Table 2 Item 1	ΔC/C	-5	+5		%
			Capacitance Change	Table 2 Item 2	I <sub>L</sub>	-	Table 2		
DC Leakage Current	Table 2 Item 3	DF	-	(3)					
08	High and Low Temperature Stability	Para. 9.14	<b>Measurements during test</b>	Tables 2 & 3	-	Tables 2 & 3			
09	Surge Voltage	Para. 9.15	<b>Final Measurements</b>	Table 2 Item 1	C	Table 2 Item 1			
			Capacitance	Table 2 Item 2					I <sub>L</sub>
			DC Leakage Current	Table 2 Item 3	DF	-	Table 2		
10	Damp Heat Steady State	Para. 9.16	<b>Initial Measurements</b>	Value recorded in 01	C	Table 2 Item 1			
			Capacitance	After recovery of 1 to 2 hours					
			<b>Final Measurements</b>	-	-	-	-		
			Visual Examination	Table 2 Item 1	ΔC/C	-5	+5		%
			Capacitance Change	Table 2 Item 2	I <sub>L</sub>	-	Table 2		
			DC Leakage Current	Table 2 Item 3	DF	-	(3)		
			Dissipation Factor						

No.	ESCC Generic Spec. No. 3012		Measurements and Inspections		Symbols	Limits		Units		
	Environmental and Endurance Tests (Note 1)	Test Methods and Conditions	Identification	Conditions		Min	Max			
11	Operating Life	Para. 9.17	<b>Initial Measurements</b>	Value recorded in 01 At 250 and 1000 hrs	C	Table 2 Item 1				
			Capacitance							
			<b>Intermediate Measurements</b>	Table 3 Item 2	I <sub>L</sub>	-	(4)			
			DC Leakage Current (2)							
			<b>Final Measurements</b>	At 1000 and 2000 hrs and after recovery or 1 to 2 hours	ΔC/C	-5	+5		%	
			Capacitance Change							Table 2 Item 1
			DC Leakage Current							Table 2 Item 2
Dissipation Factor	Table 2 Item 3									
Visual Examination	No damage	-	-					-		
12	Permanence of Marking	Para. 9.18	<b>Final Examination</b>	No corrosion or obliteration of marking	-	-	-			
			Visual Examination							
13	Solderability	Para. 9.19 and Paras. 4.2.4 and 4.2.5 of this spec	<b>Final Examination</b>	No damage	-	-	-			
			Visual Examination							

**NOTES**

1. The tests in this Table refer to either Chart IV or V and shall be used as applicable.
2. While still at the high temperature.
3. 1.2x the value specified in Table 2 of this specification.
4. 1.25x the value specified in Table 3 of this specification.
5. 1.25x the value specified in Table 2 of this specification.

**APPENDIX 'A'****AGREED DEVIATIONS FOR AVX CZECH REPUBLIC S.R.O. (CZ)**

ITEMS AFFECTED	DESCRIPTION OF DEVIATIONS
Deviations from Final Production Tests (Chart II)	Para. 9.1, Internal Visual Inspection: Shall not be performed. Para. 9.5, External Visual Inspection: Visible base material is permitted on the edges of terminations (there is no plating on edges).
Deviations from Burn-in and Electrical Measurements (Chart III)	Para. 9.5, External Visual Inspection: Visible base material is permitted on the edges of terminations (there is no plating on edges).
Deviations from Qualification Tests (Chart IV)	Para. 9.5, External Visual Inspection: Visible base material is permitted on the edges of terminations (there is no plating on edges).
Deviations from Lot Acceptance Tests (Chart V)	Para. 9.5, External Visual Inspection: Visible base material is permitted on the edges of terminations (there is no plating on edges).