



**RESISTOR ARRAY, FIXED, SURFACE MOUNT,  
THIN FILM**

**BASED ON TYPE PRA HR**

**ESCC Detail Specification No. 4001/025**

Issue 7	June 2014
---------	-----------



### **LEGAL DISCLAIMER AND COPYRIGHT**

European Space Agency, Copyright © 2014. All rights reserved.

The European Space Agency disclaims any liability or responsibility, to any person or entity, with respect to any loss or damage caused, or alleged to be caused, directly or indirectly by the use and application of this ESCC publication.

This publication, without the prior permission of the European Space Agency and provided that it is not used for a commercial purpose, may be:

- copied in whole, in any medium, without alteration or modification.
- copied in part, in any medium, provided that the ESCC document identification, comprising the ESCC symbol, document number and document issue, is removed.

**DOCUMENTATION CHANGE NOTICE**

(Refer to <https://escies.org> for ESCC DCR content)

DCR No.	CHANGE DESCRIPTION
853, 859	Specification upissued to incorporate editorial and technical changes per DCR.

**TABLE OF CONTENTS**

1	GENERAL	5
1.1	SCOPE	5
1.2	APPLICABLE DOCUMENTS	5
1.3	TERMS, DEFINITIONS, ABBREVIATIONS, SYMBOLS AND UNITS	5
1.4	THE ESCC COMPONENT NUMBER AND COMPONENT TYPE VARIANTS	5
1.4.1	The ESCC Component Number	5
1.4.1.1	Characteristics and/or Ratings Codes	5
1.4.2	Component Type Variants and Range of Components	6
1.5	MAXIMUM RATINGS	9
1.6	HANDLING PRECAUTIONS	9
1.7	PHYSICAL DIMENSIONS AND TERMINAL IDENTIFICATION	10
1.8	FUNCTIONAL DIAGRAM	11
1.9	MATERIALS AND FINISHES	11
1.9.1	Body	11
1.9.2	Terminations	11
2	REQUIREMENTS	12
2.1	GENERAL	12
2.1.1	Deviations from the Generic Specification	12
2.1.1.1	Deviations from Screening Tests (Chart F3)	12
2.1.1.2	Deviations from Qualification and Periodic Tests (Chart F4)	12
2.2	MARKING	12
2.3	OVERLOAD	12
2.4	ROBUSTNESS OF TERMINATIONS - SUBSTRATE BENDING TEST	13
2.5	RESISTANCE TO SOLDERING HEAT	13
2.6	ELECTRICAL MEASUREMENTS AT ROOM, HIGH AND LOW TEMPERATURES	13
2.6.1	Room Temperature Electrical Measurements	13
2.6.2	High and Low Temperatures Electrical Measurements	14
2.7	INTERMEDIATE AND END-POINT ELECTRICAL MEASUREMENTS	15
2.8	BURN-IN CONDITIONS	16
2.9	OPERATING LIFE CONDITIONS	17
	APPENDIX 'A'	18

## 1 GENERAL

### 1.1 SCOPE

This specification details the ratings, physical and electrical characteristics and test and inspection data for the component type variants and/or the range of components specified below. It supplements the requirements of, and shall be read in conjunction with, the ESCC Generic Specification listed under Applicable Documents.

### 1.2 APPLICABLE DOCUMENTS

The following documents form part of this specification and shall be read in conjunction with it:

(a) ESCC Generic Specification No. 4001.

### 1.3 TERMS, DEFINITIONS, ABBREVIATIONS, SYMBOLS AND UNITS

For the purpose of this specification, the terms, definitions, abbreviations, symbols and units specified in ESCC Basic Specification No. 21300 shall apply.

### 1.4 THE ESCC COMPONENT NUMBER AND COMPONENT TYPE VARIANTS

#### 1.4.1 The ESCC Component Number

The ESCC Component Number shall be constituted as follows:

Example: 4001025011001FW1 or 4001025221229FW1

- Detail Specification Reference: 4001025
- Component Type Variant Number: 01 or 22 (as required)
- Characteristic code:
  - Resistance Value (1000 $\Omega$ ): 1001 (as required for Variants 01 to 21)
  - Array Reference: 1229 (as required for Variants 22 to 42)
- Characteristic code: Absolute Resistance Tolerance ( $\pm 1\%$ ): F (as required)
- Characteristic code: Relative Resistance Tolerance ( $\pm 0.05\%$ ): W (as required)
- Characteristic code: Absolute Temperature Coefficient ( $\pm 10 \times 10^{-6}/^{\circ}\text{C}$ ): 1

#### 1.4.1.1 *Characteristics and/or Ratings Codes*

Characteristics and/or ratings to be codified as part of the ESCC Component Number shall be as follows:

##### (a) Resistance Value

For resistor arrays that are specified as having individual resistors with the same single ohmic value (Variants 01 to 21), the rated resistance value,  $R_n$ , shall be expressed by means of the following codes in accordance with ESCC Basic Specification No. 21700. The unit quantity shall be ohm ( $\Omega$ ):

Resistance Value ( $\Omega$ )	Code
XXX	XXX0
XXX $10^1$	XXX1
XXX $10^2$	XXX2
XXX $10^3$	XXX3
XXX $10^4$	XXX4

(b) Array Reference

Resistor arrays that are specified as having individual resistors with 2 or more different ohmic values (Variants 22 to 42) shall each be assigned with a unique 4 digit array reference code by the Manufacturer, to represent the specific array configuration. Each array reference code shall be held by the Manufacturer under configuration control and shall contain the following information:

- The 4 digit array reference code.
- The rated resistance value,  $R_n$ , and location for each resistor in the array.

(c) Absolute and Relative Resistance Tolerance expressed by the following codes in accordance with ESCC Basic Specification No. 21700:

Tolerance ( $\pm$ %)	Code Letter
0.05	W
0.1	B
0.5	D
1	F

(d) Absolute Temperature Coefficient expressed by the following code in accordance with ESCC Basic Specification No. 21700:

Temperature Coefficient ( $\pm 10^{-6}/^{\circ}\text{C}$ )	Code
10	1

1.4.2 Component Type Variants and Range of Components

The component type variants and range of components applicable to this specification are as follows:

Variant Number	Style (Note 1)	Same (S) or Different (D) Ohmic Values (Note 2)	Number of Resistors per Array	Resistance Range $R_n$ (Notes 3, 4)		Tolerance ( $\pm$ %)		Temperature Coefficient TC ( $\pm 10^{-6}/^{\circ}\text{C}$ )		Terminal Material and Finish	Weight max (g)
				Min ( $\Omega$ )	Max (M $\Omega$ )	Absolute	Relative	Absolute	Relative (Note 5)		
01	PRA100	S	2	100	0.2	0.1, 0.5, 1	0.05, 0.1	10	5, 3	E4	0.006
02	PRA100	S	3	100	0.2	0.1, 0.5, 1	0.05, 0.1	10	5, 3	E4	0.009
03	PRA100	S	4	100	0.2	0.1, 0.5, 1	0.05, 0.1	10	5, 3	E4	0.012

Variant Number	Style (Note 1)	Same (S) or Different (D) Ohmic Values (Note 2)	Number of Resistors per Array	Resistance Range $R_n$ (Notes 3, 4)		Tolerance ( $\pm$ %)		Temperature Coefficient TC ( $\pm 10^{-6}/^{\circ}\text{C}$ )		Terminal Material and Finish	Weight max (g)
				Min ( $\Omega$ )	Max (M $\Omega$ )	Absolute	Relative	Absolute	Relative (Note 5)		
04	PRA100	S	5	100	0.2	0.1, 0.5, 1	0.05, 0.1	10	5, 3	E4	0.015
05	PRA100	S	6	100	0.2	0.1, 0.5, 1	0.05, 0.1	10	5, 3	E4	0.018
06	PRA100	S	7	100	0.2	0.1, 0.5, 1	0.05, 0.1	10	5, 3	E4	0.021
07	PRA100	S	8	100	0.2	0.1, 0.5, 1	0.05, 0.1	10	5, 3	E4	0.024
08	PRA135	S	2	100	0.25	0.1, 0.5, 1	0.05, 0.1	10	5, 3	E4	0.008
09	PRA135	S	3	100	0.25	0.1, 0.5, 1	0.05, 0.1	10	5, 3	E4	0.012
10	PRA135	S	4	100	0.25	0.1, 0.5, 1	0.05, 0.1	10	5, 3	E4	0.016
11	PRA135	S	5	100	0.25	0.1, 0.5, 1	0.05, 0.1	10	5, 3	E4	0.02
12	PRA135	S	6	100	0.25	0.1, 0.5, 1	0.05, 0.1	10	5, 3	E4	0.024
13	PRA135	S	7	100	0.25	0.1, 0.5, 1	0.05, 0.1	10	5, 3	E4	0.028
14	PRA135	S	8	100	0.25	0.1, 0.5, 1	0.05, 0.1	10	5, 3	E4	0.032
15	PRA182	S	2	100	1	0.1, 0.5, 1	0.05, 0.1	10	5, 3	E4	0.02
16	PRA182	S	3	100	1	0.1, 0.5, 1	0.05, 0.1	10	5, 3	E4	0.03
17	PRA182	S	4	100	1	0.1, 0.5, 1	0.05, 0.1	10	5, 3	E4	0.04
18	PRA182	S	5	100	1	0.1, 0.5, 1	0.05, 0.1	10	5, 3	E4	0.05
19	PRA182	S	6	100	1	0.1, 0.5, 1	0.05, 0.1	10	5, 3	E4	0.06
20	PRA182	S	7	100	1	0.1, 0.5, 1	0.05, 0.1	10	5, 3	E4	0.07
21	PRA182	S	8	100	1	0.1, 0.5, 1	0.05, 0.1	10	5, 3	E4	0.08
22	PRA100	D	2	100	0.2	0.1, 0.5, 1	0.05, 0.1	10	5, 3	E4	0.006
23	PRA100	D	3	100	0.2	0.1, 0.5, 1	0.05, 0.1	10	5, 3	E4	0.009
24	PRA100	D	4	100	0.2	0.1, 0.5, 1	0.05, 0.1	10	5, 3	E4	0.012
25	PRA100	D	5	100	0.2	0.1, 0.5, 1	0.05, 0.1	10	5, 3	E4	0.015
26	PRA100	D	6	100	0.2	0.1, 0.5, 1	0.05, 0.1	10	5, 3	E4	0.018
27	PRA100	D	7	100	0.2	0.1, 0.5, 1	0.05, 0.1	10	5, 3	E4	0.021
28	PRA100	D	8	100	0.2	0.1, 0.5, 1	0.05, 0.1	10	5, 3	E4	0.024
29	PRA135	D	2	100	0.25	0.1, 0.5, 1	0.05, 0.1	10	5, 3	E4	0.008
30	PRA135	D	3	100	0.25	0.1, 0.5, 1	0.05, 0.1	10	5, 3	E4	0.012
31	PRA135	D	4	100	0.25	0.1, 0.5, 1	0.05, 0.1	10	5, 3	E4	0.016

Variant Number	Style (Note 1)	Same (S) or Different (D) Ohmic Values (Note 2)	Number of Resistors per Array	Resistance Range $R_n$ (Notes 3, 4)		Tolerance ( $\pm$ %)		Temperature Coefficient TC ( $\pm 10^{-6}/^{\circ}\text{C}$ )		Terminal Material and Finish	Weight max (g)
				Min ( $\Omega$ )	Max (M $\Omega$ )	Absolute	Relative	Absolute	Relative (Note 5)		
32	PRA135	D	5	100	0.25	0.1, 0.5, 1	0.05, 0.1	10	5, 3	E4	0.02
33	PRA135	D	6	100	0.25	0.1, 0.5, 1	0.05, 0.1	10	5, 3	E4	0.024
34	PRA135	D	7	100	0.25	0.1, 0.5, 1	0.05, 0.1	10	5, 3	E4	0.028
35	PRA135	D	8	100	0.25	0.1, 0.5, 1	0.05, 0.1	10	5, 3	E4	0.032
36	PRA182	D	2	100	1	0.1, 0.5, 1	0.05, 0.1	10	5, 3	E4	0.02
37	PRA182	D	3	100	1	0.1, 0.5, 1	0.05, 0.1	10	5, 3	E4	0.03
38	PRA182	D	4	100	1	0.1, 0.5, 1	0.05, 0.1	10	5, 3	E4	0.04
39	PRA182	D	5	100	1	0.1, 0.5, 1	0.05, 0.1	10	5, 3	E4	0.05
40	PRA182	D	6	100	1	0.1, 0.5, 1	0.05, 0.1	10	5, 3	E4	0.06
41	PRA182	D	7	100	1	0.1, 0.5, 1	0.05, 0.1	10	5, 3	E4	0.07
42	PRA182	D	8	100	1	0.1, 0.5, 1	0.05, 0.1	10	5, 3	E4	0.08

**NOTES:**

1. See Physical Dimensions and Terminal Identification.
2. For S types (Variants 01 to 21) all individual resistors in the resistor array have the same ohmic value,  $R_n$ .  
For D types (Variants 22 to 42) the resistor array has individual resistors with 2 or more different ohmic values.
3. The critical resistance for each style is as follows:

Variant Number	Style	Critical Resistance (k $\Omega$ )
01 to 07, 22 to 28	PRA100	12.25
08 to 14, 29 to 35	PRA135	56.25
15 to 21, 36 to 42	PRA182	100

4. Any value(s) in the resistance range to 3 significant figures can be selected.
5.  $\pm 5 \times 10^{-6}/^{\circ}\text{C}$ : if one or more resistors of the array is in the range:  $100\Omega \leq R_n \leq 250\Omega$ .  
 $\pm 3 \times 10^{-6}/^{\circ}\text{C}$ : if all resistors of the array are:  $R_n > 250\Omega$ .



1.5 MAXIMUM RATINGS

The maximum ratings shall not be exceeded at any time during use or storage.

Maximum ratings shall only be exceeded during testing to the extent specified in this specification and when stipulated in Test Methods and Procedures of the ESCC Generic Specification.

Characteristics	Variant Number	Style	Symbols	Limits	Units	Remarks
Rated Dissipation	All	All	$P_n$	100	mW/resistor	Note 1
Limiting Element Voltage	01 to 07, 22 to 28 08 to 14, 29 to 35 15 to 21, 36 to 42	PRA100 PRA135 PRA182	$U_L$	35 75 100	V	Per resistor
Rated Voltage	All	All	$U_R$	$\sqrt{(P_n \times R_n)}$	V	Per resistor Note 2
Isolation Voltage	01 to 07, 22 to 28 08 to 14, 29 to 35 15 to 21, 36 to 42	PRA100 PRA135 PRA182	$U_i$	70 150 200	Vrms	Per resistor
Operating Temperature Range	All	All	$T_{op}$	-55 to +155	°C	$T_{amb}$
Storage Temperature Range	All	All	$T_{stg}$	-55 to +155	°C	-
Soldering Temperature	All	All	$T_{sol}$	+260	°C	Note 3

**NOTES:**

1. At  $T_{amb} \leq +70^\circ\text{C}$ . For  $T_{amb} > +70^\circ\text{C}$ , derate linearly to 0W at  $T_{amb} = +155^\circ\text{C}$ .
2. Shall never exceed Limiting Element Voltage.  $R_n$  = Rated Resistance.
3. Duration 10 seconds maximum.

1.6 HANDLING PRECAUTIONS

These devices are susceptible to damage by electrostatic discharge. Therefore, suitable precautions shall be employed for protection during all phases of manufacture, testing, packaging, shipment and any handling.

These components are categorised as Class 2 per ESCC Basic Specification No. 23800 with a Minimum Critical Path Failure Voltage of 2500 Volts.

1.7 PHYSICAL DIMENSIONS AND TERMINAL IDENTIFICATION

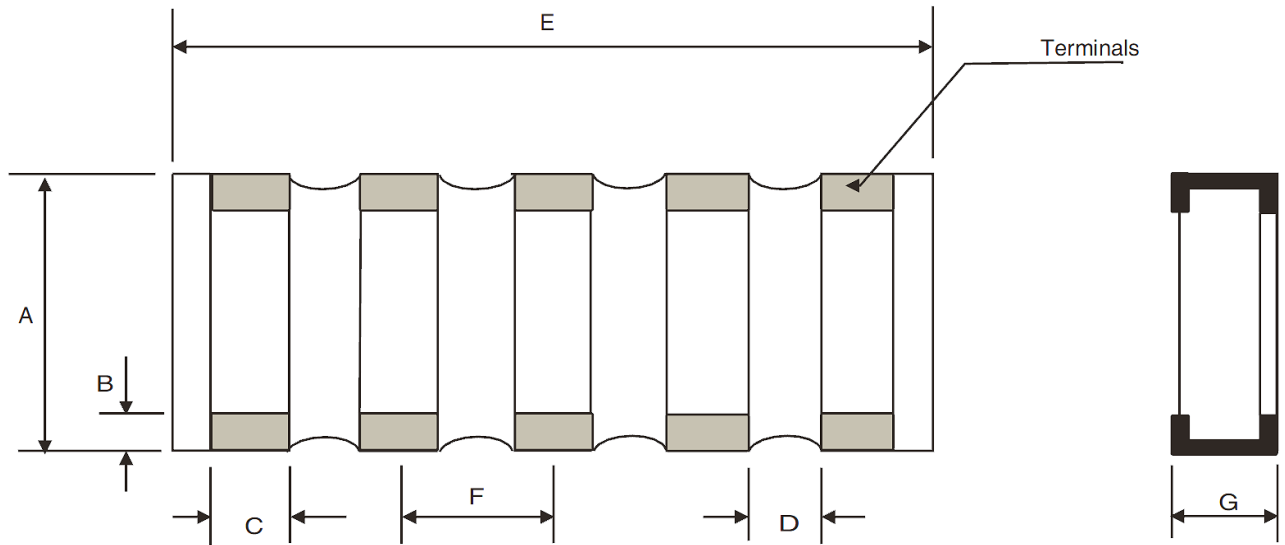

Variant Number	Style	Dimensions (mm)												
		A		B		C		D		G		F		E
		Min	Max	Min	Max	Min	Max	Min	Max	Min	Max	Min	Max	
01 to 07, 22 to 28	PRA100	1.5	1.8	0.17	0.51	0.5	0.8	0.2	0.3	0.38	0.58	0.95	1.05	Note 1
08 to 14, 29 to 35	PRA135	1.75	2.05	0.17	0.51	0.9	1.2	0.2	0.3	0.38	0.58	1.3	1.4	Note 1
15 to 21, 36 to 42	PRA182	2.9	3.2	0.17	0.51	1.15	1.45	0.2	0.3	0.38	0.58	1.77	1.87	Note 1

**NOTES:**

1.  $E = (N \times F) \pm 0.3\text{mm}$ , where N = number of resistors per array (N = 2 to 8).
2. Terminal identification shall be by means of the location of the marking. Due to the size of the component only the 4 digit resistance value code or array reference code, as applicable (see The ESCC Component Number), shall be marked on the component.  
For symmetrical marking using reversible figures such as 0, 6 or 9, the first resistor of the array, R<sub>1</sub>, shall be identified by a dot.  
For arrays with 2 or 3 resistors, the marking shall be located adjacent to the first 2 resistors of the array. The first resistor, R<sub>1</sub>, of the array is the upper resistor whilst reading the marking, as follows:

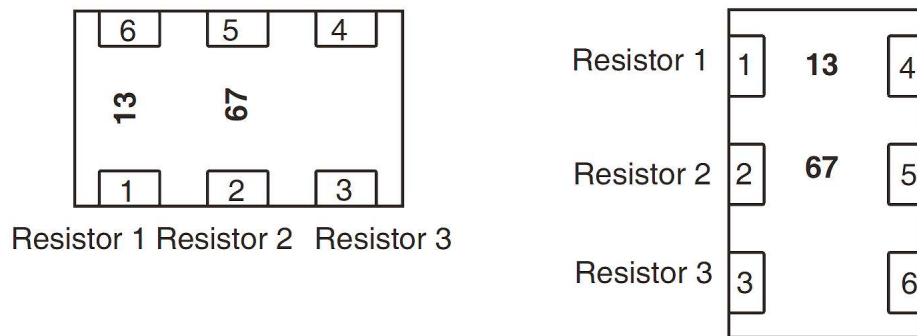

For arrays with 4 to 8 resistors, the marking shall be located adjacent to the first 4 resistors of the array. The first resistor,  $R_1$ , of the array is on the left hand end of the array whilst reading the marking, as follows:

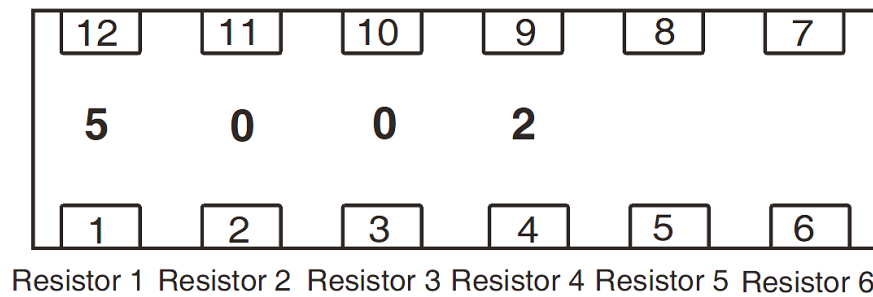

1.8 FUNCTIONAL DIAGRAM

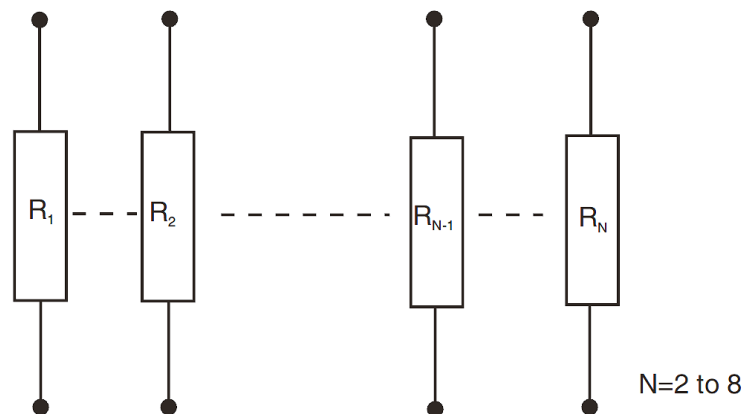

1.9 MATERIALS AND FINISHES

1.9.1 Body

Each resistive element deposited on the alumina substrate shall be covered with a suitable coating.

1.9.2 Terminations

The terminal material and finish shall be as specified in Component Type Variants and Range of Components in accordance with the requirements of ESCC Basic Specification No. 23500.

## 2 REQUIREMENTS

### 2.1 GENERAL

The complete requirements for procurement of the components specified herein are as stated in this specification and the ESCC Generic Specification. Permitted deviations from the Generic Specification, applicable to this specification only, are listed below.

Permitted deviations from the Generic Specification and this Detail Specification, formally agreed with specific Manufacturers on the basis that the alternative requirements are equivalent to the ESCC requirement and do not affect the component's reliability, are listed in the appendices attached to this specification.

#### 2.1.1 Deviations from the Generic Specification

##### 2.1.1.1 *Deviations from Screening Tests (Chart F3)*

- (a) Para. 8.2, Non-Linearity: Voltage on each resistor of the array =  $\sqrt{P_n \times R_{min}}$  or  $2U_L$ , whichever is less ( $R_{min}$  is the lowest ohmic value of the array).

##### 2.1.1.2 *Deviations from Qualification and Periodic Tests (Chart F4)*

- (a) Para. 8.9, Vibration: Not applicable.  
(b) Para. 8.10, Climatic Sequence: Voltage applied during the Low Air Pressure test: as per Burn-in herein.

### 2.2 MARKING

The marking of all components delivered to this specification shall be in accordance with the requirements of ESCC Basic Specification No. 21700. When the component is too small to accommodate all of the marking specified, as much as space permits shall be marked and the marking information, in full, shall accompany each component in its primary package.

The information to be marked and the order of precedence, shall be as follows:

- (a) Rated Resistance (for Variants 01 to 21); Terminal identification and array reference code (for Variants 22 to 42) (see Physical Dimensions and Terminal Identification)  
(b) The ESCC qualified components symbol (for ESCC qualified components only).  
(c) The ESCC Component Number.  
(d) Traceability information.

### 2.3 OVERLOAD

The test conditions for Overload, tested as specified in the ESCC Generic Specification, shall be as follows:

Voltage on each resistor of the array :  $\sqrt{6.25P_n \times R_{min}}$  or  $2U_L$ , whichever is less ( $R_{min}$  is the lowest ohmic value of the array).

Duration : 2s minimum.

2.4 ROBUSTNESS OF TERMINATIONS - SUBSTRATE BENDING TEST

The test conditions for the Substrate Bending Test, tested as specified in the ESCC Generic Specification, shall be as follows:

- Number of bends : 10.
- Deflection : 2mm (all Variants)
- Duration : 5 ±1s
- Orientation : Same orientation as for a single resistor

2.5 RESISTANCE TO SOLDERING HEAT

The test conditions for Resistance to Soldering Heat, tested as specified in the ESCC Generic Specification, shall be as follows:

- Temperature : 260 °C
- Duration : 10 (+0 -1) s

2.6 ELECTRICAL MEASUREMENTS AT ROOM, HIGH AND LOW TEMPERATURES

2.6.1 Room Temperature Electrical Measurements

The measurements shall be performed at T<sub>amb</sub> = +22 ±3 °C.

Characteristics	Symbols	ESCC 4001 Test Method and Conditions	Tolerance (± %)	Limits		Units
				Min	Max	
Resistance	R <sub>A</sub>	Para. 8.3.1.1 Note 1	0.1	0.999 R <sub>n</sub>	1.001 R <sub>n</sub>	Ω
			0.5	0.995 R <sub>n</sub>	1.005 R <sub>n</sub>	
			1	0.99 R <sub>n</sub>	1.01 R <sub>n</sub>	
Relative Tolerance	ΔT <sub>R</sub>	Para. 8.3.1.1 Note 2	0.05 0.1	-0.05 -0.1	+0.05 +0.1	%
Insulation Resistance	R <sub>I</sub>	Para. 8.3.1.2 V = 100V Note 3	All	1000	-	MΩ

**NOTES:**

1. The measurements shall be performed on all the individual resistors of the array.
2.  $\Delta T_R = \text{Max} \left[ \frac{R_A - R_n}{R_n} \right] - \text{Min} \left[ \frac{R_A - R_n}{R_n} \right]$   
The calculations shall be performed between all the resistor pairs of the array.
3. Guaranteed but not tested during Screening Tests.

2.6.2 High and Low Temperatures Electrical Measurements

Characteristics	Symbols	ESCC 4001 Test Method and Conditions	Limits		Unit
			Min	Max	
Resistance Change between -55 (+3 -0) °C and +22 ±3 °C	$\Delta R_A/R_A$	Para. 8.3.1.1 Notes 1 and 2	-0.08	+0.08	%
Resistance Change between +155 (+0 -3) °C and +22 ±3 °C	$\Delta R_A/R_A$	Para. 8.3.1.1 Notes 1 and 2	-0.136	+0.136	%
Relative Temperature Coefficient -55 (+3 -0) °C	$\Delta TC_R$	Para. 8.3.1.1 Notes 2 and 3	-3	+3	$10^{-6}/^{\circ}C$
		Para. 8.3.1.1 Notes 2 and 3	-5	+5	
Relative Temperature Coefficient -155 (+3 -0) °C	$\Delta TC_R$	Para. 8.3.1.1 Notes 2 and 3	-3	+3	$10^{-6}/^{\circ}C$
		Para. 8.3.1.1 Notes 2 and 3	-5	+5	

**NOTES:**

1. The measurements shall be performed on all the individual resistors of the array.
2. The measurements shall be performed on a sample of 5 components selected from the total production lot. The components shall be mounted as specified in the ESCC Generic Specification.
3. See Component Type Variants and Range of Components Note 5.

$$\Delta TC_R = \text{Max} \left[ \frac{R_{A(T^{\circ})} - R_{A(T)}}{R_{A(T^{\circ})}} \cdot \frac{1}{(T^{\circ} - T)} \right] - \text{Min} \left[ \frac{R_{A(T^{\circ})} - R_{A(T)}}{R_{A(T^{\circ})}} \cdot \frac{1}{(T^{\circ} - T)} \right]$$

The calculations are done between all the resistor pairs of the array.

(T°) is the reference temperature of the test method (+22 ±3 °C).

(T) is the high (+155 (+0 -3) °C) or the low (-55 (+3 -0) °C) testing temperature.

2.7 INTERMEDIATE AND END-POINT ELECTRICAL MEASUREMENTS

The components shall be mounted as specified in the ESCC Generic Specification.

Unless otherwise specified, the measurements shall be performed at  $T_{amb} = +22 \pm 3 \text{ }^\circ\text{C}$ .

Unless otherwise specified the test methods and test conditions shall be as per the corresponding test defined in Room Temperature Electrical Measurements.

Test Reference per ESCC No. 4001	Characteristics	Symbols	Limits		Units
			Min	Max	
Rapid Change of Temperature Initial Measurement  Final Measurement	Resistance	$R_A$	Record Values		%
	Relative Tolerance	$\Delta T_R$	See Para. 2.6.1		
	Change in Resistance	$\Delta R_A / R_A$	$\pm (0.05 + 0.05\Omega \times 100 / R_n)$		
	Relative Tolerance	$\Delta T_R$	See Para. 2.6.1		
Robustness of Terminations Initial Measurement  Final Measurement	Resistance	$R_A$	Record Values		%
	Relative Tolerance	$\Delta T_R$	See Para. 2.6.1		
	Change in Resistance	$\Delta R_A / R_A$	$\pm (0.05 + 0.05\Omega \times 100 / R_n)$		
	Relative Tolerance	$\Delta T_R$	See Para. 2.6.1		
Resistance to Soldering Heat Initial Measurement  Final Measurement	Resistance	$R_A$	Record Values		%
	Relative Tolerance	$\Delta T_R$	See Para. 2.6.1		
	Change in Resistance	$\Delta R_A / R_A$	$\pm (0.05 + 0.05\Omega \times 100 / R_n)$		
	Relative Tolerance	$\Delta T_R$	See Para. 2.6.1		
Solderability Initial Measurement  Final Measurement	Resistance	$R_A$	Record Values		%
	Relative Tolerance	$\Delta T_R$	See Para. 2.6.1		
	Change in Resistance	$\Delta R_A / R_A$	$\pm (0.05 + 0.05\Omega \times 100 / R_n)$		
	Relative Tolerance	$\Delta T_R$	See Para. 2.6.1		

Test Reference per ESCC No. 4001	Characteristics	Symbols	Limits		Units
			Min	Max	
Climatic Sequence Initial Measurements (Procedure 1)  Final Measurements	Resistance (after drying)	$R_A$	Record Values		%
	Relative Tolerance	$\Delta T_R$	See Para. 2.6.1		
	Relative Tolerance	$\Delta T_R$	See Para. 2.6.1		
	Change in Resistance	$\Delta R_A/R_A$	$\pm (0.1 + 0.05\Omega \times 100 / R_n)$		
	Insulation Resistance ( $V_T = 100V$ )	$R_I$	1000	-	
Operating Life Initial Measurement (0 hour)  Intermediate Measurements (1000 hours)  Final Measurements (2000 hours)	Resistance	$R_A$	Record Values		%
	Relative Tolerance	$\Delta T_R$	See Para. 2.6.1		
	Relative Tolerance	$\Delta T_R$	See Para. 2.6.1		
	Change in Resistance	$\Delta R_A/R_A$	$\pm (0.1 + 0.05\Omega \times 100 / R_n)$		
	Relative Tolerance	$\Delta T_R$	See Para. 2.6.1		
	Change in Resistance	$\Delta R_A/R_A$	$\pm (0.15 + 0.05\Omega \times 100 / R_n)$		
	Insulation Resistance ( $V_T = 100V$ )	$R_I$	1000	-	

2.8

**BURN-IN CONDITIONS**

Characteristics	Symbols	Test Conditions	Units
Ambient Temperature	$T_{amb}$	+70 $\pm$ 5	$^{\circ}C$
Test Voltage	$V_T$		V
Variants 01 to 21		$\sqrt{(P_n \times R_n)}$ or $U_L$ , whichever is less	
Variants 22 to 42		$\sqrt{(P_n \times R_{min})}$ or $U_L$ , whichever is less	

**NOTES**

- $V_T$  is applied to each individual resistor.  $R_{min}$  is the lowest ohmic value of the array.
- After Burn-in, the components shall be removed from the chamber and allowed to cool under normal atmospheric conditions for a minimum of 4 hours.





- 2.9 OPERATING LIFE CONDITIONS  
The conditions shall be as specified for Burn-in.

**APPENDIX 'A'**  
**AGREED DEVIATIONS FOR VISHAY S.A. DIVISION SFERNICE (F)**

Items Affected	Description of Deviations
Deviations from Generic Specification:  Screening Tests (Chart F3)	Para. 8.2, Non-Linearity: Not applicable.
High and Low Temperatures Electrical Measurements	All tests at high and low temperatures are guaranteed but not tested based on temperature coefficient and relative temperature coefficient measurements performed on each wafer at +25°C and +75°C in accordance with VISHAY specification CM-SF-00210.