



**CABLE, LOW MASS, “SPACEWIRE”, ROUND,  
QUAD USING SYMMETRIC CABLES, FLEXIBLE,  
-100 TO +150°C**

**ESCC Detail Specification No. 3902/004**

Issue 1	October 2014
---------	--------------



Document Custodian: European Space Agency – see <https://escies.org>

**LEGAL DISCLAIMER AND COPYRIGHT**

European Space Agency, Copyright © 2014. All rights reserved.

The European Space Agency disclaims any liability or responsibility, to any person or entity, with respect to any loss or damage caused, or alleged to be caused, directly or indirectly by the use and application of this ESCC publication.

This publication, without the prior permission of the European Space Agency and provided that it is not used for a commercial purpose, may be:

- copied in whole, in any medium, without alteration or modification.
- copied in part, in any medium, provided that the ESCC document identification, comprising the ESCC symbol, document number and document issue, is removed.



**DOCUMENTATION CHANGE NOTICE**

(Refer to <https://escies.org> for ESCC DCR content)

DCR No.	CHANGE DESCRIPTION

**TABLE OF CONTENTS**

1	GENERAL	7
1.1	SCOPE	7
1.2	COMPONENT TYPE VARIANTS	7
1.3	MAXIMUM RATINGS	7
1.4	PARAMETER DERATING INFORMATION (FIGURE 1)	7
1.5	PHYSICAL DIMENSIONS AND CHARACTERISTICS	7
1.6	FUNCTIONAL DIAGRAM	7
	TABLE 1(A) - TYPE VARIANTS	8
	TABLE 1(B) - MAXIMUM RATINGS	8
	FIGURE 1 – PARAMETER DERATING INFORMATION	9
	FIGURE 2 - PHYSICAL CHARACTERISTICS	9
2	APPLICABLE DOCUMENTS	10
3	TERMS, DEFINITIONS, ABBREVIATIONS, SYMBOLS AND UNITS	10
4	REQUIREMENTS	11
4.1	GENERAL	11
4.2	DEVIATIONS FROM GENERIC SPECIFICATION	11
4.2.1	Deviations from Special In-Process Controls	11
4.2.2	Deviations from Final Production Tests (Chart II)	11
4.2.3	Deviations from Burn-in and Electrical Measurements (Chart III)	11
4.2.4	Deviations from Qualification Tests (Chart IV)	11
4.2.5	Deviations from Lot Acceptance Tests (Chart V)	11
4.3	MECHANICAL REQUIREMENTS	11
4.3.1	Dimension Check	11
4.3.2	Weight	12
4.3.3	Adhesion of the Inner Conductor	12
4.4	MATERIALS AND FINISHES	13
4.4.1	Construction of Round Cable	13
4.4.1.1	Generic Construction	13
4.4.1.2	Lay Length of Symmetric Cables	13
4.4.1.3	Lay Length of the Complete Round Cable	13
4.4.2	Inner Conductor	13
4.4.2.1	Material Characteristics	13
4.4.2.2	Stranding	14
4.4.3	Dielectric	14
4.4.3.1	Material	14
4.4.3.2	Construction	14

4.4.4	Filler	14
4.4.4.1	Material	14
4.4.4.2	Construction	14
4.4.5	Shield	14
4.4.5.1	Material Characteristics	14
4.4.5.2	Construction	15
4.4.6	Jacket	15
4.4.6.1	Material Characteristics	15
4.4.6.2	Construction	15
4.4.7	Colours	15
4.5	MARKING	16
4.5.1	General	16
4.5.2	The ESCC Component Number	16
4.5.3	Characteristics	16
4.5.4	Traceability Information	16
4.5.5	Additional Marking	16
4.6	ELECTRICAL MEASUREMENTS	16
4.6.1	Electrical Measurements at Room Temperature	16
4.6.2	Electrical Measurements at High and Low Temperatures	16
4.6.3	Circuits for Electrical Measurements	16
4.7	BURN-IN TESTS	17
4.8	ENVIRONMENTAL AND ENDURANCE TESTS (CHARTS IV AND V OF ESCC GENERIC SPECIFICATION NO. 3902)	17
4.8.1	Mechanical Properties of Conductors	17
4.8.2	Alternate Bending Resistance	17
TABLE A - ALTERNATE BENDING RESISTANCE, LOAD AND DIAMETER		17
4.8.3	Accelerated Ageing Stability	17
TABLE B - SHRINKAGE/PROTRUSION		17
4.8.4	Cold Bend Test	17
TABLE C - COLD BEND TEST, MANDREL DIAMETER AND LOADS		17
4.8.5	Solderability	17
4.8.6	Corona Extinction Voltage	17
4.8.7	Resistance to Fluids	17
4.8.8	Flammability Resistance	18
4.8.9	Radiation Resistance	18
4.8.10	Outgassing	18
4.8.11	Long-term Ageing Test	18



4.8.12	Atomic Oxygen Resistance	18
4.8.13	Voltage Test	18
4.8.14	Characteristic Impedance	18
4.8.15	Attenuation	18
4.8.16	Structural Return Loss	18
4.8.17	Transfer Impedance	19
FIGURE 3 - MAXIMUM TRANSFER IMPEDANCE		19
4.8.18	Time Delay	19
4.8.19	Time Delay Conductor Difference	20
TABLE 2 - ELECTRICAL MEASUREMENTS AT ROOM TEMPERATURE		21
APPENDIX A		22

## 1 GENERAL

### 1.1 SCOPE

This specification details the ratings, physical and electrical characteristics, test and inspection data for cable, low mass, "spacewire", round, quad using symmetric cables, flexible, -100 to +150°C. It shall be read in conjunction with ESCC Generic Specification No. 3902, the requirements of which are supplemented herein.

### 1.2 COMPONENT TYPE VARIANTS

Variants of the basic types of datalines specified herein, which are also covered by this specification are given in Table 1(a).

### 1.3 MAXIMUM RATINGS

The maximum ratings, which shall not be exceeded at any time during use or storage, applicable to the finished datalines specified herein, are as scheduled in Table 1(b).

### 1.4 PARAMETER DERATING INFORMATION (FIGURE 1)

The derating information applicable to the finished wires and cables specified herein is as follows:

- The maximum current for each wire used in a bundle shall be:

$$I_{Bmax} = I_{max} \times \frac{29-n}{28} \quad (\text{for } 1 \leq n \leq 15)$$

$$I_{Bmax} = \frac{I_{max}}{2} \quad (\text{for } n > 15)$$

where n = number of wires in the bundle

- The temperature derating information is shown in Figure 1 with maximum current  $I_{max}$  for a single wire.
- The derating factors contained herein indicate maximum stress values and do not preclude further derating.

### 1.5 PHYSICAL DIMENSIONS AND CHARACTERISTICS

The physical dimensions and characteristics of the datalines specified herein, are shown in Table 1(a) and Figure 2 respectively.

### 1.6 FUNCTIONAL DIAGRAM

Not applicable.

**TABLE 1(a) - TYPE VARIANTS**

Variant	Z <sub>0</sub> (Ω)	AWG	Inner Conductor (Wire)				Insulated Wire Max Ø (mm)	Filler SC Ø (mm)	Inner Shield SC	
			No. of Strands x Ø (mm)	Max Ø (mm)	Nom. Sect. (mm <sup>2</sup> )	Max DC Resistance (Ω/km)			Constr.	Strand Ø (mm)
01	100	28	19 x 0.079	0.43	0.095	256	1.1	0.75	BS	0.079

Variant	Symmetric Cable Characteristics		Filler RC Ø (mm)	Outer Shield RC		Round Cable Characteristics		Bend Radius Min (mm)
	Max Ø (mm)	Max Weight (kg/km)		Constr.	Strand Ø (mm)	Max Ø (mm)	Max Weight (kg/km)	
01	2.7	8.5	1.4	BS	0.102	6.5	42	25

**TABLE 1(b) - MAXIMUM RATINGS**

No.	Characteristics	Symbol	Maximum Rating	Unit	Remarks
1	Operating Voltage (Continuous)	V <sub>op</sub>	200	Vrms	-
2	Current	I <sub>max</sub>	1.5	A	Single wire See Figure 1
3	Operating Frequency	f <sub>M</sub>	400	MHz	10 metres
4	Data Transmission Rate	DTR	400	Mbit/s	Assembly
5	Operating Temperature Range	T <sub>op</sub>	-100 to +150	°C	T <sub>amb</sub> Note 1
6	Storage Temperature Range	T <sub>stg</sub>	-100 to +150	°C	-
7	Soldering Temperature	T <sub>sol</sub>	+250	°C	Note 2

**NOTES:**

1. Precautions shall be taken such that the aggregate temperature of the datalines (ambient plus rise), due to power dissipation, does not exceed the maximum operating temperature.
2. For 5 seconds maximum.



**FIGURE 1 – PARAMETER DERATING INFORMATION**

**ALLOWABLE CURRENT FOR A SINGLE WIRE VERSUS TEMPERATURE**

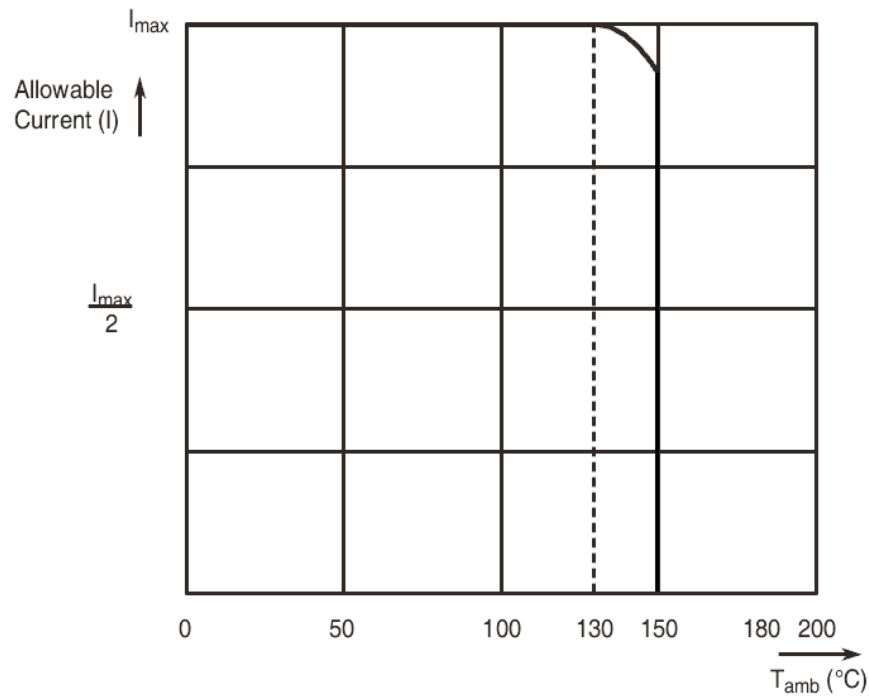

**NOTES:**

1. The maximum temperature is limited to  $T_{amb} = +150^{\circ}\text{C}$  due to the use of aluminium for the shield material.

**FIGURE 2 - PHYSICAL CHARACTERISTICS**

**FIGURE 2(a) - SINGLE SYMMETRIC CABLE - VARIANT 01**

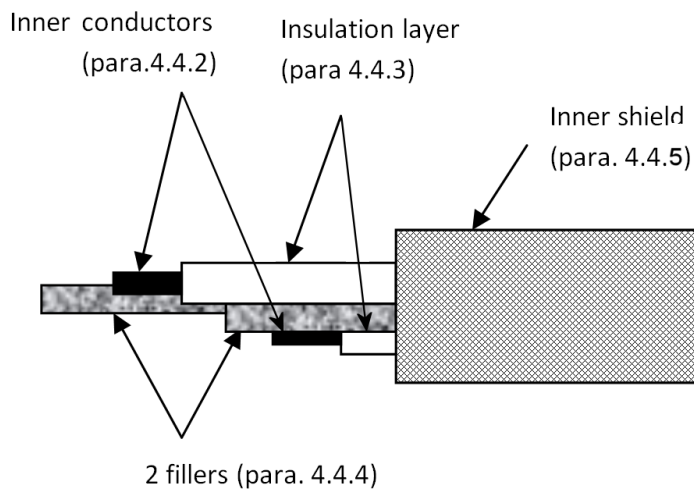

**NOTES:**

1. See Table 1(a) for dimensions.

FIGURE 2(b) - ROUND CABLE - VARIANT 01

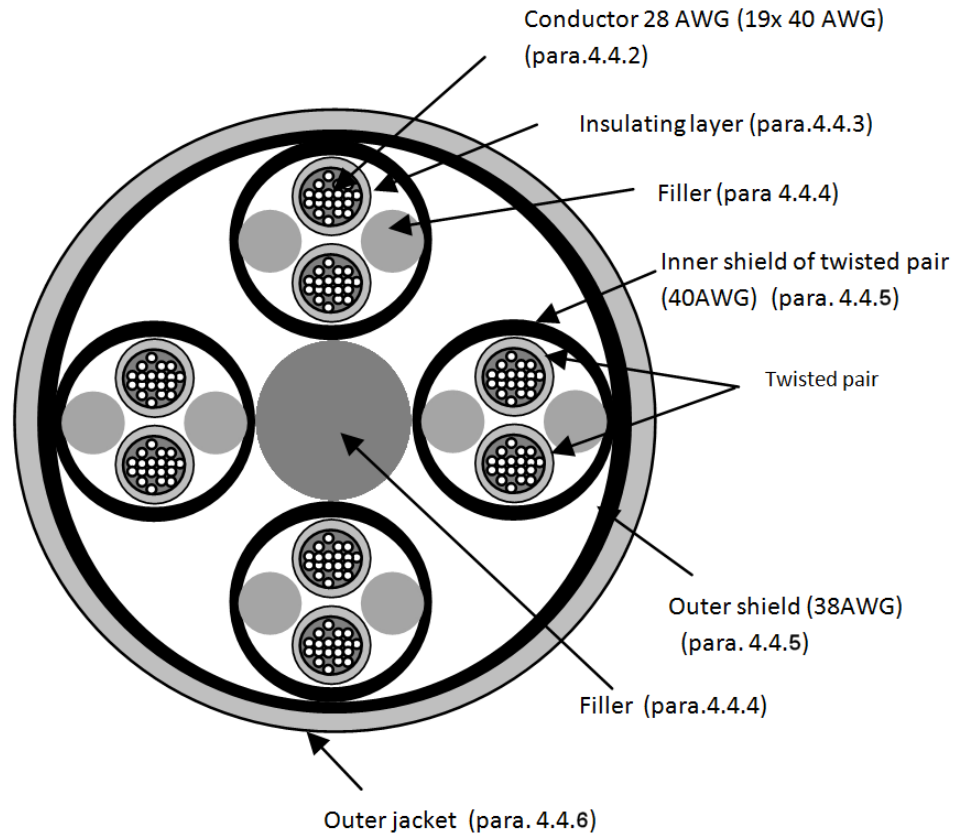

**NOTES:**

1. The inner shields of all 4 symmetric cables are electrically in contact with the outer shield.

**2 APPLICABLE DOCUMENTS**

The following documents form part of this specification and shall be read in conjunction with it:

- (a) ESCC Generic Specification No. 3902 for Cables, Coaxial, Radio Frequency, Flexible.
- (b) MIL-DTL-17, General Specification for Cables, Radio Frequency, Flexible and Semirigid.
- (c) IEC Publication No. 96-1, Radio Frequency Cables, Part 1: General Requirements and Measuring Methods.

**3 TERMS, DEFINITIONS, ABBREVIATIONS, SYMBOLS AND UNITS**

For the purpose of this specification, the terms, definitions, abbreviations, symbols and units specified in ESCC Basic Specification No. 21300 and ESCC Generic Specification No. 3902 shall apply. In addition, the following definitions shall be used:

- |                 |   |                           |
|-----------------|---|---------------------------|
| Cables          | = | Datalines (general term). |
| Symmetric Cable | = | Balanced Shielded Lines.  |
| BS              | = | Braided Shield.           |
| SC              | = | Symmetric Cable.          |
| RC              | = | Round Cable.              |

## 4 REQUIREMENTS

### 4.1 GENERAL

The complete requirements for procurement of the finished round cable specified herein shall be as stated in this specification and ESCC Generic Specification No. 3902. Deviations from the Generic Specification, applicable to this Detail Specification only, are listed in Para. 4.2.

Deviations from the applicable Generic Specification and this Detail Specification, formally agreed with specific Manufacturers on the basis that the alternative requirements are equivalent to the ESCC requirements and do not affect the components' reliability, are listed in the appendices attached to this specification.

### 4.2 DEVIATIONS FROM GENERIC SPECIFICATION

#### 4.2.1 Deviations from Special In-Process Controls

(a) Para. 5.3.1, Insulation Flaws (Spark Test): shall be performed using 1.0kV at 3.0kHz.

#### 4.2.2 Deviations from Final Production Tests (Chart II)

- (a) Para. 9.7, Voltage Test: to be performed in accordance with Para. 4.8.13 of this specification.
- (b) Para. 9.10, Characteristic Impedance: to be performed in accordance with Para. 4.8.14 of this specification.
- (c) Para. 9.12, Structural Return Loss: shall not be performed.

#### 4.2.3 Deviations from Burn-in and Electrical Measurements (Chart III)

None.

#### 4.2.4 Deviations from Qualification Tests (Chart IV)

- (a) Para. 9.7, Voltage Test: to be performed in accordance with Para. 4.8.13 of this specification.
- (b) Para. 9.10, Characteristic Impedance: to be performed in accordance with Para. 4.8.14 of this specification.
- (c) Para. 9.12, Structural Return Loss: shall not be performed.
- (d) Transfer Impedance: shall be performed in accordance with Para. 4.8.17 of this specification at any point in Chart IV.

#### 4.2.5 Deviations from Lot Acceptance Tests (Chart V)

- (a) Para. 9.12, Structural Return Loss: shall not be performed.

### 4.3 MECHANICAL REQUIREMENTS

#### 4.3.1 Dimension Check

The dimensions of the datalines specified herein shall be checked. They shall conform to those shown in Table 1(a), Figure 2 and Para. 4.4 of this specification (see the Table following for list of parameters to be checked).

LIST OF PARAMETERS TO BE CHECKED

PARAMETER	TABLE 1(a)	FIGURE 2	PARA 4.4
<b>COMPOSITION</b>			
- Conductor Gauge	X		
- Number of Conductors	X		
- Shielding	X		
- Number of Shields and Type		X	
- Jacket			X
<b>INNER CONDUCTOR</b>			
- Nature			X
- Outer Diameter	X		
- Number of Strands	X		
- Strand Diameter	X		
- Silver Thickness			X
- Length of Lay			X
<b>DIELECTRIC CORE</b>			
- Composition		X	X
- Nature			X
- Thickness	X		
- Concentricity			X
- Outer Diameter	X		
<b>SHIELDING</b>			
- Number of Strands			X
- Type of Shielding			X
- Strand Diameter	X		
- Silver Thickness			X
- Shielding Lay			X
- Shield Coverage			X
<b>FILLER</b>			
- Nature		X	X
- Outer Diameter	X		
<b>JACKET</b>			
- Composition			X
- Thickness			X
- Outer Diameter	X		

4.3.2 Weight

The maximum weight of the datalines specified herein shall be measured in accordance with Para. 9.2 of ESCC Generic specification No. 3902 and shall be as specified in Table 1(a) of this specification.

4.3.3 Adhesion of the Inner Conductor

Minimum stripping force: 1N.

4.4 MATERIALS AND FINISHES

The materials and finishes shall be as specified herein. Where a definite material is not specified, a material which will enable the components specified herein to meet the performance requirements of this specification shall be used. Acceptance or approval of any constituent material does not guarantee acceptance of the finished product.

4.4.1 Construction of Round Cable

4.4.1.1 *Generic Construction*

The round cable with symmetric cables consists of four impedance controlled datalines with an overall shield and outer jacket. See Figure 2.

The datalines are constructed such that two conductors, each evenly centred within a dielectric, are twisted together with two fillers and then covered by a shield in accordance with Figure 2(a).

4.4.1.2 *Lay Length of Symmetric Cables*

The lay length of all symmetric cables twisted together shall not be less than 12 times and not more than 16 times the outside diameter of the unshielded and unjacketed cable. This requirement will lead to the following lay length and/or twist per metre respectively.

Lay Length (mm)		Twists/m	
Min	Max	Min	Max
24	32	32	41

4.4.1.3 *Lay Length of the Complete Round Cable*

Four sets of symmetric cables twisted together shall not be less than 12 times and not more than 16 times the outside diameter of two symmetric cables:

This construction shall be the core to be covered by a braided shield, i.e. outer conductor. This construction is then covered by an outer jacket in accordance with Figure 2(b).

Lay Length (mm)	
Min	Max
57	77

4.4.2 Inner Conductor

4.4.2.1 *Material Characteristics*

All strands used in the manufacture of the conductor shall be silver-coated high strength copper alloy.

On silver-coated strands, the thickness of silver shall be 2µm minimum.

For high strength copper alloy conductors, the tensile characteristics shall be not less than 6% in elongation and 35kg/mm<sup>2</sup> in tensile strength.

For determination of the conductor resistance at +20°C, as mentioned in Para. 9.5 of ESCC Generic Specification No. 3902, the α coefficient for copper alloy is 0.0035.

#### 4.4.2.2 *Stranding*

The conductors shall be constructed of concentrically laid strands so as to produce a smooth and uniform conductor of circular cross-section and free from any high strands or other surface irregularities.

The length of lay of the external layer shall be not less than 8, nor more than 16 times the maximum conductor diameter specified in Table 1(a).

#### 4.4.3 Dielectric

##### 4.4.3.1 *Material*

Any dielectric material shall be virgin material, i.e. alveolar PTFE, with only those additives that are necessary for processing and pigmentation.

##### 4.4.3.2 *Construction*

The dielectric shall have a uniform cross-section throughout the length of the inner core or wire and the conductor shall be evenly centred in the dielectric.

The nominal diameter of the dielectric shall be in accordance with Table 1(a)(insulated wire).

#### 4.4.4 Filler

Fillers shall be used so as to ensure a smooth and uniform diameter under the shielding in order to contribute to a uniform impedance over the length of the cable.

##### 4.4.4.1 *Material*

The filler material as used for the symmetric cables shall be expanded, microporous PTFE with only those additives necessary for processing.

The filler material as used for the round cable shell shall be PTFE with only the additives necessary for processing.

##### 4.4.4.2 *Construction*

The filler material shall be extruded or wrapped from tapes to the diameters as given in Table 1(a).

#### 4.4.5 Shield

The terms "inner shield" and "outer shield" shall be used.

1 type of shield shall be used:

- Braided Shield (BS)

#### **NOTES:**

1. The inner shields of all 4 symmetric cables are electrically in contact with the outer shield.

##### 4.4.5.1 *Material Characteristics*

All strands shall be made of silver-plated aluminium. The thickness of silver shall be 2.5µm minimum.

All strands in the inner shield shall show a 6% minimum elongation. All strands in the outer shield shall show a 5% minimum elongation.

#### 4.4.5.2 Construction

The strand size shall be as specified in Table 1(a) of this specification.

**Braided Shield:** The braided shield type shall be of push-back type and provide not less than 90% coverage. The coverage factor K is calculated as follows:

$$K = (2F - F^2)$$

$$F = \frac{N \times P \times d}{\sin \alpha}$$

$$\tan \alpha = 2\pi \frac{(D \times 2d) \times P}{C}$$

K = coverage (%).

N = number of strands.

P = serving pitch/mm.

d = shield strand diameter (mm).

$\alpha$  = angle of shield with cable axis in degrees.

D = effective diameter of core under shield (mm).

C = number of carriers.

#### 4.4.6 Jacket

The cable shall have an outer jacket for the complete round cable.

##### 4.4.6.1 Material Characteristics

The material shall be polyimide tape, coated with FEP adhesive on the inside surface, wrapped over an expanded microporous PTFE tape. The wrapped tapes shall be heat-sealed.

##### 4.4.6.2 Construction

Expanded microporous PTFE tape (with a nominal tape thickness of 0.05mm) and polyimide tape (with a nominal tape thickness of 0.038mm) are wrapped over the construction. The wall thickness shall be 0.1mm nominal for the wrapped PTFE and 0.076mm nominal for the wrapped polyimide.

The expanded microporous PTFE tape shall be wrapped with an overlap of 50% maximum. The polyimide tape shall be wrapped with an overlap of 51% maximum.

#### 4.4.7 Colours

For each single symmetric cable, one wire shall have white dielectric material and the other shall have blue.

Different filler colours will be used to differentiate each single symmetric cable of the round cable: white, blue, red, black.

The jacket colour shall be natural polyimide colour.

#### 4.5 MARKING

##### 4.5.1 General

The marking of all spools of finished datalines delivered to this specification shall be in accordance with the requirements of ESCC Basic Specification No. 21700. Each spool shall be marked in respect of:

- (a) The ESCC Component Number.
- (b) Characteristics
- (c) Traceability Information.
- (d) Additional Marking.

##### 4.5.2 The ESCC Component Number

The ESCC Component Number shall be constituted and marked as follows:

Example: 390200401B

- Detail Specification Number: 3902004
- Type Variant (See Table 1(a)): 01
- Testing Level: B

##### 4.5.3 Characteristics

The characteristics shall show the length(s) of the finished dataline wound on each spool and shall be marked as follows:

Example: 100m

- Length in metres (see Note): 100
- Symbol for metres: m

#### **NOTES:**

1. Whenever the length is less than 100 metres, insert a zero in the first block (example: 075m) If more than 1 length of finished dataline is wound on a spool, the characteristics of each length shall be marked as above.

##### 4.5.4 Traceability Information

Each spool shall be marked in respect of Traceability information in accordance with ESCC Basic Specification No. 21700.

##### 4.5.5 Additional Marking

Each spool shall bear the Manufacturer's Quality Control Inspector's stamp.

#### 4.6 ELECTRICAL MEASUREMENTS

##### 4.6.1 Electrical Measurements at Room Temperature

The parameters to be measured at room temperature are scheduled in Table 2. Unless otherwise specified these measurements shall be performed at  $T_{amb} = +22 \pm 3^{\circ}\text{C}$ .

##### 4.6.2 Electrical Measurements at High and Low Temperatures

Not applicable.

##### 4.6.3 Circuits for Electrical Measurements

Not applicable



4.7 BURN-IN TESTS

Not applicable.

4.8 ENVIRONMENTAL AND ENDURANCE TESTS (CHARTS IV AND V OF ESCC GENERIC SPECIFICATION No. 3902)

4.8.1 Mechanical Properties of Conductors

As detailed in Paras. 4.4.2.1 and 4.4.5.1 of this specification.

4.8.2 Alternate Bending Resistance

The applied weights and bending diameter for alternate bending resistance are given in Table A.

Number of cycles: 500 minimum.

TABLE A - ALTERNATE BENDING RESISTANCE, LOAD AND DIAMETER

Z <sub>0</sub> (Ω)	Weight (kg)	Bending Diameter (mm)
100	1.3	30

4.8.3 Accelerated Ageing Stability

Ageing temperature : +150 (+0 -5)°C

Shrinkage/Protrusion : See Table B.

Wrap Test : Mandrel diameters as per Table C.

TABLE B - SHRINKAGE/PROTRUSION

Z <sub>0</sub> (Ω)	Maximum Shrinkage or Protrusion (mm)
100	2

Maximum Capacitance Change : +7%

4.8.4 Cold Bend Test

Chamber temperature : -80 ±5°C

Mandrel diameter and load : See Table C.

TABLE C - COLD BEND TEST, MANDREL DIAMETER AND LOADS

Variant	Z <sub>0</sub> (Ω)	Weight (kg)	Mandrel Diameter (mm)
01	100	1.3	20

4.8.5 Solderability

No particular conditions are applicable.

4.8.6 Corona Extinction Voltage

As per Table 2.

4.8.7 Resistance to Fluids

No particular conditions are applicable.

4.8.8 Flammability Resistance

No particular conditions are applicable.

4.8.9 Radiation Resistance

- (a) Insulation Resistance: Shall stay within specified limits, see Table 2.
- (b) Voltage Test: Shall stay within specified limits, see Table 2.
- (c) Maximum Capacitance Change: +7%.
- (d) Maximum Impedance Change: +7%.
- (e) Corona extinction voltage: Shall stay within specified limits, see Table 2.

4.8.10 Outgassing

No particular conditions are applicable.

4.8.11 Long-term Ageing Test

Ageing temperature: +150 (+0 -5)°C.

- (a) Insulation Resistance: Shall stay within specified limits, see Table 2.
- (b) Voltage Test: Shall stay within specified limits, see Table 2.
- (c) Maximum Capacitance Change: +7%.
- (d) Maximum Impedance Change: +7%.
- (e) Corona extinction voltage: Shall stay within specified limits, see Table 2.

4.8.12 Atomic Oxygen Resistance

The outer surface of the datalines is resistant against atomic oxygen and shall be verified in accordance with the requirements of the ESCC Executive.

4.8.13 Voltage Test

The voltage test shall be performed in accordance with ESCC Generic specification No. 3902, Para. 9.7 with the exception that the whole length of each produced lot shall be tested with the DC voltages specified in Table 2 for a minimum of 1 minute.

4.8.14 Characteristic Impedance

The characteristic impedance of all symmetric cables shall be measured according to MIL-DTL-17, Para. 4.8.7 using a time domain reflectometer (TDR), with a symmetrical input/output. All measurements shall be performed on cables with a minimum length of 3 metres.

Impedance reference shall be defined before test.

4.8.15 Attenuation

As per Table 2.

4.8.16 Structural Return Loss

Not applicable.

4.8.17 Transfer Impedance

The transfer impedance of the cables shall be determined. Since the transfer impedance is a characteristic which is dependent only on constructional parameters, its performance shall be measured only once during qualification in accordance with IEC 96-1, 46 A 142 and Figure 3 of this specification.

**FIGURE 3 - MAXIMUM TRANSFER IMPEDANCE**

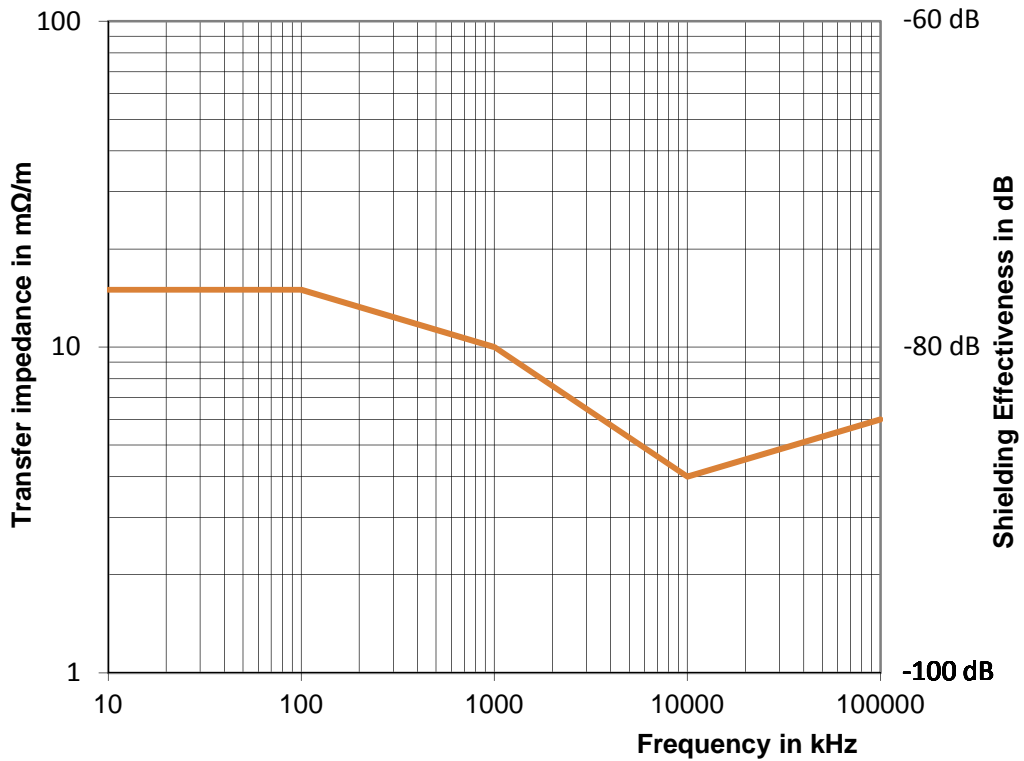

4.8.18 Time Delay

The time delay of the balanced shielded lines shall be measured in accordance with Table 2 using a network analyser on a minimum length of 3 metres.

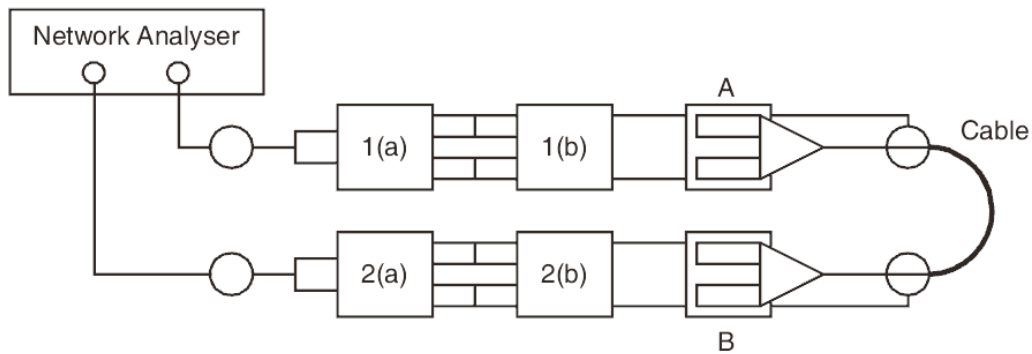

1(a) and 2(a) : Symmetrical Transformers (1 x 50Ω to 2 x 50Ω)

1(b) and 2(b) : Impedance Matching (50Ω to 75/100/120Ω)

A and B : Clamp connection

A symmetrical 50Ω signal will be produced by the network analyser (0.3 - 3000MHz), split into 2 symmetrical signals 1(a) and transformed to the desired impedance of the balanced shielded line under test 1(b). After the signal has passed the cable under measurement, the signal will be impedance matched to 50Ω 2(b) and retransformed to a single signal 2(a).

The specimen cable is connected to input and output A and B, and the time delay between input and output is measured and displayed by the network analyser.

4.8.19 Time Delay Conductor Difference

The time delay conductor difference of the balanced shielded lines shall be measured in accordance with Table 2 using a network analyser on a minimum length of 3 metres.

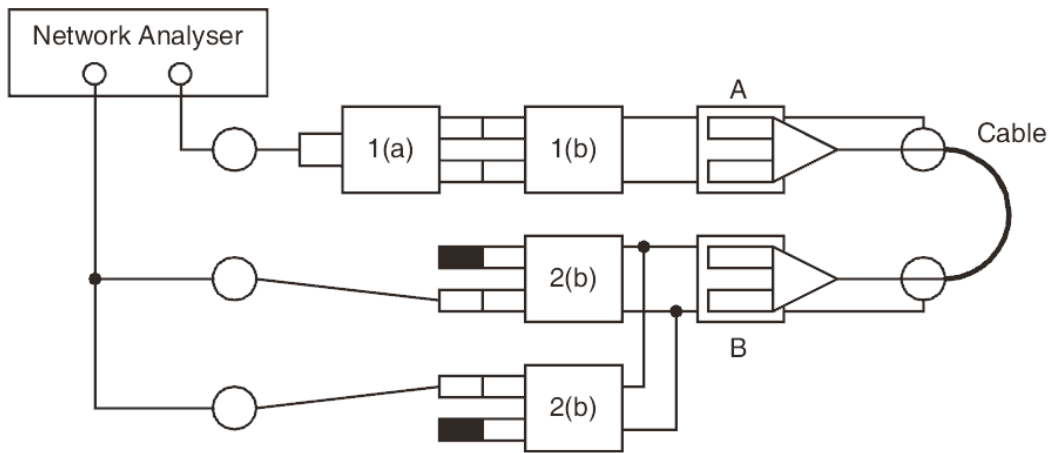

- 1(a) and 2(a) : Symmetrical Transformers (1 x 50Ω to 2 x 50Ω)
- 1(b) and 2(b) : Impedance Matching (50Ω to 75/100/120Ω)
- A and B : Clamp connection

A symmetrical 50Ω signal will be produced by the network analyser (0.3 - 3000MHz), split into 2 symmetrical signals 1(a) and transformed to the desired impedance of the balanced shielded line under test 1(b). After the signal has passed 1 line of the symmetric cable, connected to input A and output B, the signal will be impedance matched to 50Ω 2(b). The 1 open port of the impedance matching pad will be terminated by 50Ω.

This procedure shall be repeated for the second single line of the symmetric cable, and both values shall be compared, with the conductor difference displayed by the network analyser.

**TABLE 2 - ELECTRICAL MEASUREMENTS AT ROOM TEMPERATURE**  
**ROUND CABLES**

No.	Characteristic	Test Method and Conditions	Limits		Units
			Min	Max	
1	Dielectric Strength of Jacket	ESCC No. 3902 Para. 9.6	2	-	kVac
2	Voltage Test (Dielectric Core)	ESCC No. 3902 Para. 9.7	1.4		kVdc
3	Capacitance – Conductor to Conductor	ESCC No. 3902 Para. 9.9	-	50	pF/m
4	Capacitance – Conductor to Shield	ESCC No. 3902 Para. 9.9	-	90	pF/m
5	Characteristic Impedance	ESCC No. 3902 Para. 9.10	94	106	$\Omega$
6	Corona Extinction Voltage	ESCC No. 3902 Para. 9.20	500	-	Vac
7	Conductor Resistance	ESCC No. 3902 Para. 9.5	-	See Table1(a)	$\Omega$ /km
8	Insulation Resistance	ESCC No. 3902 Para. 9.8	5000	-	M $\Omega$ x km

**SYMMETRIC CABLES**

9	Transfer Impedance	Para. 4.8.17	-	See Figure 3	m $\Omega$ /m
10	Attenuation	ESCC No. 3902 Para. 9.11 At 250MHz At 500MHz At 1000MHz	- - -	0.7 1 1.4	dB/m
11	Time Delay	Para. 4.8.18	-	4.3	ns/m
12	Conductor Time Delay Difference – Per Pair	Para. 4.8.19	-	0.05	ns/m
13	Conductor Time Delay Difference – Pair to Pair	Para. 4.8.19	-	0.1	ns/m

**APPENDIX A**  
**AGREED DEVIATIONS FOR AXON' CABLE (F)**

ITEMS AFFECTED	DESCRIPTION OF DEVIATIONS
Deviations from Final Production Tests (Chart II) and Table 2 - Electrical Measurements At Room Temperature	Para. 9.11, Attenuation may be performed in accordance with Axon test specification document 09048-TSD-A01.
Deviations from Qualification Tests (Chart IV) and Table 2 - Electrical Measurements At Room Temperature	Para. 9.11, Attenuation may be performed in accordance with Axon test specification document 09048-TSD-A01.
Deviations from Lot Acceptance Tests (Chart V) and Table 2 - Electrical Measurements At Room Temperature	Para. 9.11, Attenuation may be performed in accordance with Axon test specification document 09048-TSD-A01.
Table 2 - Electrical Measurements At Room Temperature	Para. 4.8.18, Time Delay may be performed in accordance with Axon test specification document 09048-TSD-A01.
Table 2 - Electrical Measurements At Room Temperature	Para. 4.8.19, Time Delay Conductor Difference may be performed in accordance with Axon test specification document 09048-TSD-A01.