



Page 1 of 41

**CONNECTORS, ELECTRICAL, NON-FILTERED,
CIRCULAR AND RECTANGULAR**

ESCC Generic Specification No. 3401

Issue 3	November 2014
---------	---------------



Document Custodian: European Space Agency – see <https://escies.org>

LEGAL DISCLAIMER AND COPYRIGHT

European Space Agency, Copyright © 2013, All rights reserved.

The European Space Agency disclaims any liability or responsibility, to any person or entity, with respect to any loss or damage caused, or alleged to be caused, directly or indirectly by the use and application of this ESCC publication.

This publication, without the prior permission of the European Space Agency and provided that it is not used for a commercial purpose, may be:

- copied in whole, in any medium, without alteration or modification.
- copied in part, in any medium, provided that the ESCC document identification, comprising the ESCC symbol, document number and document issue, is removed.

DOCUMENTATION CHANGE NOTICE

(Refer to <https://escies.org> for ESCC DCR content)

DCR No.	CHANGE DESCRIPTION
877	Specification upissued to incorporate editorial changes per DCR.

TABLE OF CONTENTS

1	INTRODUCTION	9
1.1	SCOPE	9
1.2	APPLICABILITY	9
2	APPLICABLE DOCUMENTS	9
2.1	ESCC SPECIFICATIONS	9
2.2	OTHER (REFERENCE) DOCUMENTS	10
2.3	ORDER OF PRECEDENCE	10
3	TERMS, DEFINITIONS, ABBREVIATIONS, SYMBOLS AND UNITS	10
4	REQUIREMENTS	10
4.1	GENERAL	10
4.1.1	Specifications	10
4.1.2	Conditions and Methods of Test	10
4.1.3	Manufacturer's Responsibility for Performance of Tests and Inspections	11
4.1.4	Inspection Rights	11
4.1.5	Pre-encapsulation Inspection	11
4.2	QUALIFICATION APPROVAL REQUIREMENTS ON A MANUFACTURER	11
4.3	DELIVERABLE COMPONENTS	11
4.3.1	Lot Failure	11
4.3.2	Testing and Lot Acceptance Levels	12
4.4	MARKING	12
4.5	MATERIALS AND FINISHES	12
5	PRODUCTION CONTROL	12
5.1	GENERAL	12
5.2	SPECIAL IN-PROCESS CONTROLS	12
5.2.1	External Visual Inspection	12
5.2.2	Gold Plate Porosity	13
5.2.3	Plating Thickness	13
5.2.4	Crimping Capability	13
5.2.5	Solderability	13
5.3	DOCUMENTATION	13
6	FINAL PRODUCTION TESTS	15
6.1	GENERAL	15
6.2	TEST METHODS AND CONDITIONS	15
6.3	FAILURE CRITERIA	15
6.3.1	Parameter Drift Failure	15
6.3.2	Parameter Limit Failure	15

6.3.3	Other Failures	15
6.4	FAILED COMPONENTS	15
6.5	LOT FAILURE	15
6.5.1	Lot Failure during 100% Testing	15
6.5.2	Lot Failure during Sample Testing	16
6.6	DOCUMENTATION	16
7	BURN-IN AND ELECTRICAL MEASUREMENTS (CHART III)	16
8	QUALIFICATION APPROVAL AND LOT ACCEPTANCE TESTS	16
8.1	QUALIFICATION TESTING	16
8.1.1	General	16
8.1.2	Distribution within the Qualification Test Lot	16
8.2	LOT ACCEPTANCE TESTING	17
8.2.1	General	17
8.2.2	Distribution within the Sample Lot for Lot Acceptance Testing	17
8.2.3	Lot Acceptance Level 3 Testing (LA3)	17
8.2.4	Lot Acceptance Level 2 Testing (LA2)	17
8.2.5	Lot Acceptance Level 1 Testing (LA1)	18
8.3	FAILURE CRITERIA	18
8.3.1	Environmental and Mechanical Test Failures	18
8.3.2	Electrical Failures	18
8.3.3	Other Failures	18
8.4	FAILED COMPONENTS	18
8.5	LOT FAILURE	19
8.6	DOCUMENTATION	19
9	TEST METHODS AND PROCEDURES	24
9.1	ELECTRICAL MEASUREMENTS	24
9.1.1	Electrical Test Methods	24
9.1.1.1	Insulation Resistance	24
9.1.1.2	Voltage Proof (Sea Level)	24
9.1.1.3	Contact Resistance	25
9.1.1.4	Mated Shell Conductivity	26
9.1.1.5	VSWR	27
9.1.1.6	Insertion Loss	27
9.1.2	Parameter Drift Value Measurements	27
9.1.3	Electrical Measurements at High and Low Temperatures	27
9.1.4	Electrical Measurements at Room Temperature	27

9.1.5	Electrical Measurements during Endurance Testing	27
9.2	MATING VERIFICATION	27
9.3	CONTACT RETAINER TEST	27
9.3.1	Applicability	27
9.3.2	Procedure	27
9.4	CONTACT CAPABILITY	28
9.5	MAGNETISM LEVEL	28
9.6	DIMENSION CHECK	28
9.7	EXTERNAL VISUAL INSPECTION	28
9.8	INSTALLATION OF CONTACTS INTO INSERT	29
9.9	SEAL TEST	29
9.10	WIRING	29
9.10.1	Solder Contacts	29
9.10.2	Crimp Contacts	29
9.10.3	Wire-Wrap Contacts	30
9.11	VIBRATION	30
9.11.1	General	30
9.11.2	Sinusoidal Vibration Testing	31
9.11.3	Random Vibration Testing	31
9.12	SHOCK OR BUMP	31
9.12.1	Shock	31
9.12.2	Bump	31
9.13	CLIMATIC SEQUENCE	32
9.13.1	Initial Measurements	32
9.13.2	Dry Heat	32
9.13.3	Damp Heat, Accelerated, First Cycle	32
9.13.4	Cold Test	32
9.13.5	Low Air Pressure	32
9.13.6	Damp Heat, Accelerated, Remaining Cycles	32
9.13.7	Recovery and Final Inspection	32
9.13.8	Final Measurements	32
9.14	PLATING THICKNESS	33
9.15	JOINT STRENGTH	33
9.15.1	Applicability	33
9.15.2	General Procedure	33
9.15.3	Crimp Contacts	33



9.15.4	Wire-Wrap Contacts	33
9.15.5	Coaxial Contacts	33
9.16	RAPID CHANGE OF TEMPERATURE	34
9.17	CONTACT RETENTION (IN INSERT)	34
9.17.1	General	34
9.17.2	Non-removable Contacts	34
9.17.3	Removable Contacts	34
9.18	ENDURANCE	34
9.19	PERMANENCE OF MARKING	35
9.20	MATING AND UNMATING FORCES	35
9.21	HIGH TEMPERATURE STORAGE	35
9.22	CORROSION	36
9.23	INSERT RETENTION (IN SHELL)	36
9.23.1	Environment Resistant Connectors	36
9.23.2	Hermetic Connectors	36
9.24	JACKSCREW RETENTION (CONNECTORS WITH A JACKSCREW)	36
9.25	HIGH TEMPERATURE MEASUREMENTS	36
9.26	OVERLOAD TEST	37
9.27	MAINTENANCE AGING (REMOVABLE CONTACTS ONLY)	37
9.28	ENGAGEMENT AND SEPARATION FORCES	37
9.29	OVERSIZE PIN EXCLUSION	38
9.30	PROBE DAMAGE	38
9.31	SOLDERABILITY	38
9.31.1	Solder Contacts	38
9.31.2	PCB Contacts	38
10	DATA DOCUMENTATION	38
10.1	GENERAL	38
10.1.1	Qualification Approval	39
10.1.2	Testing Level 'B'	39
10.1.2.1	Qualified Components	39
10.1.2.2	Unqualified Components	39
10.1.3	Testing Level 'C'	39
10.1.4	Data Retention/Data Access	39
10.2	COVER SHEET(S)	39
10.3	LIST OF EQUIPMENT USED	39
10.4	LIST OF TEST REFERENCES	40



10.5	SPECIAL IN-PROCESS CONTROL DATA	40
10.6	FINAL PRODUCTION TEST DATA (CHART II)	40
10.7	BURN-IN AND ELECTRICAL MEASUREMENT DATA (CHART III)	40
10.8	QUALIFICATION TEST DATA (CHART IV)	40
10.9	LOT ACCEPTANCE TEST DATA (CHART V)	40
10.9.1	Testing Level 'B'	40
10.9.2	Testing Level 'C'	40
10.10	FAILED COMPONENTS LIST AND FAILURE ANALYSIS REPORT	41
10.11	CERTIFICATE OF CONFORMITY	41
11	DELIVERY	41
12	PACKAGING AND DESPATCH	41

1 INTRODUCTION

1.1 SCOPE

This specification defines the general requirements for the qualification approval, procurement, including lot acceptance, and delivery of mating pairs of Connectors, Electrical, Non-Filtered, Circular and Rectangular, hermetic or non-hermetic, with removable or non-removable contacts, for space application.

This specification contains the appropriate inspection and test schedules and also specifies the data documentation requirements.

1.2 APPLICABILITY

This specification is primarily applicable to the granting of qualification approval to a component in accordance with ESCC Basic Specification No. 20100 and the procurement of such components from qualified Manufacturers.

2 APPLICABLE DOCUMENTS

The following documents form part of, and shall be read in conjunction with, this specification. The relevant issues shall be those in effect at the date of placing the purchase order.

2.1 ESCC SPECIFICATIONS

- (a) ESCC Basic Specification No. 20100, Requirements for the Qualification of Standard Electronic Components for Space Application.
- (b) ESCC Basic Specification No. 20500, External Visual Inspection.
- (c) ESCC Basic Specification No. 20600, Preservation, Packaging and Despatch of ESCC Electronic Components.
- (d) ESCC Basic Specification No. 21300, Terms, Definitions, Abbreviations, Symbols and Units.
- (e) ESCC Basic Specification No. 21700, General Requirements for the Marking of ESCC Components.
- (f) ESCC Basic Specification No. 22800, ESCC Non-conformance Control System.
- (g) ESCC Basic Specification No. 23500, Requirements for Lead Materials and Finishes for Components for Space Application.
- (h) ESCC Basic Specification No. 24600, Minimum Quality System Requirements.
- (i) ESCC Basic Specification No. 24800, Resistance to Solvents of Marking, Materials and Finishes.
- (j) ESCC Generic Specification No. 3402, Connectors, RF Coaxial.

With the exception of ESCC Basic Specifications No. 20100, 21700, 22800 and 24600 where Manufacturers' specifications are equivalent to, or more stringent than, the ESCC Basic Specifications listed above, they may be used in place of the latter, subject to the approval of the ESCC Executive.

Such replacements shall be clearly identified in the applicable Process Identification Document (PID) and listed in an Appendix to the appropriate Detail Specification.

Unless otherwise stated herein, reference within the text of this specification to "the Detail Specification" shall mean the relevant ESCC Detail Specification.

2.2 OTHER (REFERENCE) DOCUMENTS

- (a) ESA PSS-01-702, A Thermal Vacuum Test for the Screening of Space Materials.
- (b) ESA PSS-01-708, The Manual Soldering of High-Reliability Electrical Connections.
- (c) ESA PSS-01-726, The Crimping of High-Reliability Electrical Connections.
- (d) ESA PSS-01-730, The Wire Wrapping of High-Reliability Electrical Connections.
- (e) IEC Publication No. 68, Basic Environmental Testing Procedures.
- (f) IEC Publication No. 410, Sampling Procedures and Tables for Inspection by Attributes.
- (g) IEC Publication No. 512, Electromechanical Components for Electronic Equipment, Basic
- (h) Testing Procedures and Measuring Methods.

2.3 ORDER OF PRECEDENCE

For the purpose of interpretation and in the case of conflict with regard to documentation, the following order of precedence shall apply:

- (a) ESCC Detail Specification.
- (b) ESCC Generic Specification.
- (c) ESCC Basic Specification.
- (d) Other documents if referenced herein.

3 TERMS, DEFINITIONS, ABBREVIATIONS, SYMBOLS AND UNITS

The terms, definitions, abbreviations, symbols and units specified in ESCC Basic Specification No. 21300 shall apply.

4 REQUIREMENTS

4.1 GENERAL

The test requirements for qualification approval of a component shall comprise final production tests (see Chart II) and qualification testing (see Chart IV).

The test requirements for procurement of components shall comprise final production tests (see Chart II) together with, when applicable, a level of lot acceptance testing (see Chart V) to be specified by the Orderer.

If a Manufacturer elects to eliminate a final production test by substituting an in-process control or statistical process control procedure, the Manufacturer is still responsible for delivering components that meet all of the performance, quality and reliability requirements defined in this specification and the Detail Specification.

4.1.1 Specifications

For qualification approval, procurement (including lot acceptance testing) and delivery of components in conformity with this specification, the specifications listed in Section 2 of this document shall apply in total unless otherwise specified herein or in the Detail Specification.

4.1.2 Conditions and Methods of Test

The conditions and methods of test shall be in accordance with this specification, the ESCC Basic Specifications referenced herein and the Detail Specification.

4.1.3 Manufacturer's Responsibility for Performance of Tests and Inspections

The Manufacturer shall be responsible for the performance of tests and inspections required by the applicable specifications. These tests and inspections shall be performed at the plant of the Manufacturer of the components unless it is agreed by the ESCC Executive prior to commencing qualification testing, or procurement, to use an approved external facility.

4.1.4 Inspection Rights

The ESCC Executive (for qualification approval or for a procurement) reserves the right to monitor any of the tests and inspections scheduled in the applicable specifications.

4.1.5 Pre-encapsulation Inspection

Not applicable.

4.2 QUALIFICATION APPROVAL REQUIREMENTS ON A MANUFACTURER

To obtain and maintain the qualification approval of a component, or family of components, a Manufacturer shall satisfy the requirements of ESCC Basic Specification No. 20100.

4.3 DELIVERABLE COMPONENTS

Components delivered to this specification shall be processed and inspected in accordance with the relevant Process Identification Document (PID). Each delivered component shall be traceable to its production lot. Components delivered to this specification shall have completed satisfactorily all tests to the testing level and lot acceptance level specified in the purchase order (see Para. 4.3.2).

ESCC qualified components delivered to this specification shall be produced from lots that are capable of passing all tests, and sequences of tests, that are defined in Charts IV and V. The Manufacturer shall not knowingly supply components that cannot meet this requirement. In the event that, subsequent to delivery and prior to operational use, a component is found to be in a condition such that it could not have passed these tests at the time of manufacture, this shall be grounds for rejection of the delivered lot.

4.3.1 Lot Failure

Lot failure may occur during final production tests (Chart II), qualification testing (Chart IV) or lot acceptance testing (Chart V).

Should such failure occur, the non-conformance procedure shall be initiated in accordance with ESCC Basic Specification No. 22800. Should such failure occur during procurement, the Manufacturer shall notify the Orderer by telex within 2 working days, giving details of the number and mode of failure and the suspected cause.

In the case where qualification approval has been granted to the component, he shall, at the same time by the same means, inform the ESCC Executive in order that the latter may consider its implications. No further testing shall be performed on the failed components except on instructions from the Orderer. The Orderer shall inform the Manufacturer and the ESCC Executive within 2 working days from the receipt of the telex, by the same means, what action shall be taken.

In the case where lot failure occurs during qualification testing, the Manufacturer shall immediately notify the ESCC Executive who will define a course of action to be followed. No further testing shall be performed on the failed components.

4.3.2 Testing and Lot Acceptance Levels

This specification defines 1 level of testing severity which is designated by the letter 'B' (see Chart I) and 3 levels of lot acceptance testing (see Chart V).

The Lot Acceptance levels are designated 1, 2 and 3 and are comprised of tests as follows:

Level 3 (LA3) - None.

Level 2 (LA2) - Endurance Subgroups.

Level 1 (LA1) - Environmental and Mechanical Subgroup plus Endurance Subgroup.

The required lot acceptance level shall be specified in a purchase order.

4.4 MARKING

All components procured and delivered to this specification from a source qualified according to ESCC Basic Specification No. 20100 shall be marked in accordance with ESCC Basic Specification No. 21700.

Thus, they shall bear the ESA symbol to signify their conformance to the ESCC qualification approval requirements and full compliance with the requirements of this specification and the Detail Specification.

Components procured from sources which are not ESCC qualified, provided that they fully comply with the procurement requirements of this specification and the Detail Specification, may bear the ESCC marking **with the exception of the ESA symbol.**

4.5 MATERIALS AND FINISHES

All non-metallic materials and finishes that are not within a hermetically sealed enclosure, of the components specified herein, shall meet the outgassing requirements as outlined in ESA PSS-01-702. Specific requirements for materials and finishes are specified in the Detail Specification.

5 PRODUCTION CONTROL

5.1 GENERAL

The minimum requirements for production control, which are equally applicable to procurement, are defined in ESCC Basic Specification No. 20100, Paras. 5.1 and 5.2.

5.2 SPECIAL IN-PROCESS CONTROLS

5.2.1 External Visual Inspection

Before assembly, the different elements of the connectors shall be visually inspected in accordance with ESCC Basic Specification No. 20500.

5.2.2 Gold Plate Porosity

A sample of 10 contacts from each plating lot shall be placed in a clean glass container. A solution of 1 part of concentrated nitric acid (specific gravity: 1.42) and 1 part of distilled water at a temperature of $+25 \pm 5^{\circ}\text{C}$ shall be poured over the contacts. No bubbles shall emanate from the contact surfaces within 15 seconds from application of the solution.

5.2.3 Plating Thickness

The thickness of the outer gold layer and barrier layers shall be measured on 10 male and 10 female contacts, using a non-destructive method or metallographic cross section on the active part as specified in the Detail Specification. In the event of conflict, the metallographic cross sectioning method shall govern (see the Detail Specification for values). Hermetic receptacles shall be broken to free the contacts or shall be microsectioned along two or more contacts in order to determine the plating thickness. It is not necessary to verify the thickness of underlayers that are not barrier layers.

5.2.4 Crimping Capability

10 contacts shall be crimped onto the minimum gauge wire as specified in the Detail Specification using the Manufacturer approved crimping tools and procedure. The crimp joints shall be inspected in accordance with, and meet the requirements of, the visual inspection criteria of ESA PSS-01-726.

5.2.5 Solderability

10 solder or PCB contacts shall be submitted to a solderability test in accordance with Para. 9.31 of this specification. This special in-process control is not applicable to contacts using gold plated terminations.

5.3 DOCUMENTATION

Documentation of special in-process controls shall be in accordance with the requirements of Para. 10.5 of this specification.

CHART I – TESTING LEVELS

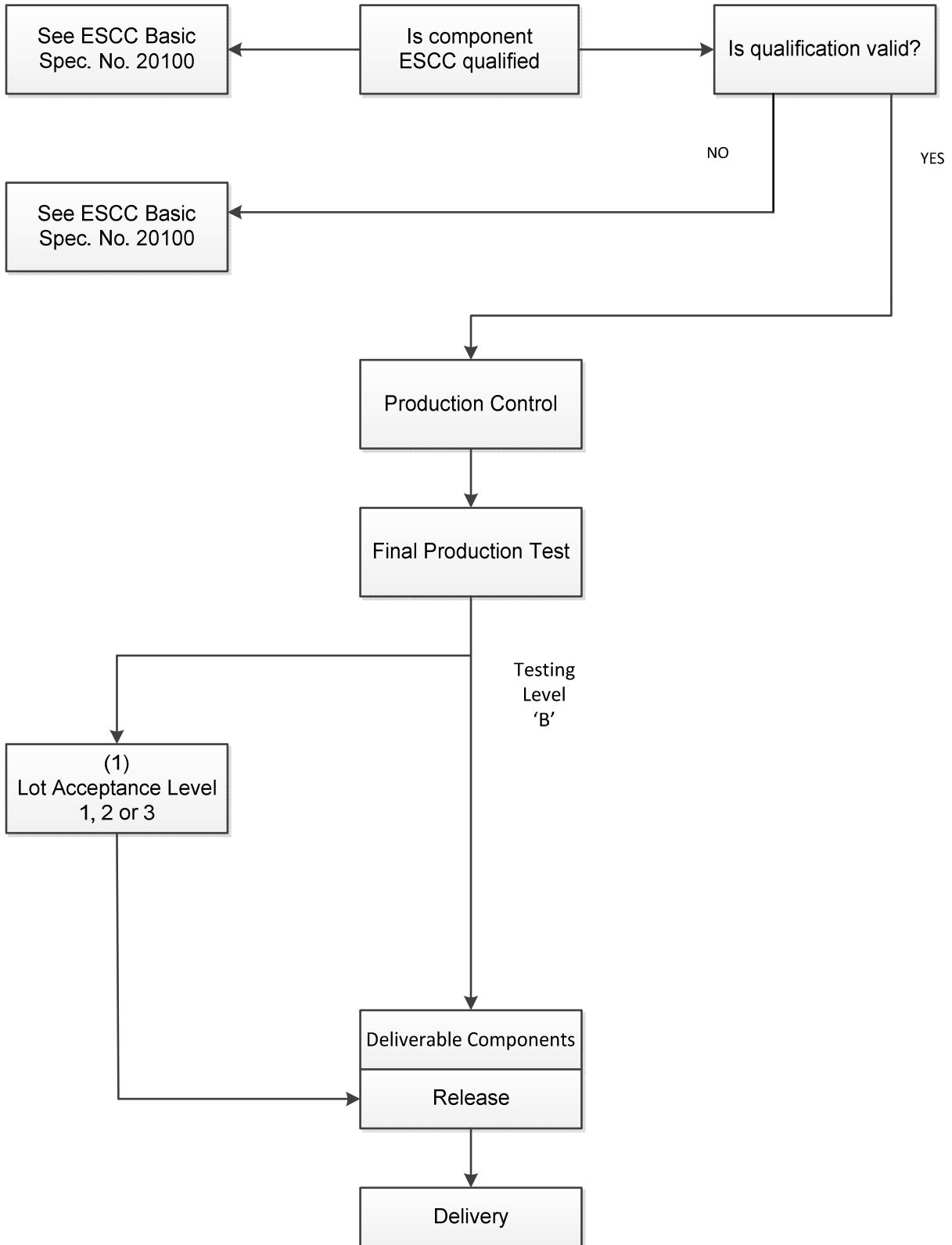

NOTES

1. When applicable.

6 FINAL PRODUCTION TESTS

6.1 GENERAL

Unless otherwise specified in the Detail Specification, all components used for qualification testing and all components for delivery, including those submitted to lot acceptance tests, shall be subjected to tests and inspections in accordance with Chart II.

Unless otherwise specified in the Detail Specification, the tests shall be performed in the order shown.

Any components that do not meet these requirements shall be removed from the lot and at no future time be re-submitted to the requirements of this specification.

6.2 TEST METHODS AND CONDITIONS

The applicable test methods and conditions are specified in the paragraphs referenced in Chart II of this specification.

6.3 FAILURE CRITERIA

6.3.1 Parameter Drift Failure

Not applicable.

6.3.2 Parameter Limit Failure

A component shall be counted as a limit failure if one or more parameters exceed the limits shown in Table 2 of the Detail Specification.

6.3.3 Other Failures

A component shall be counted as a failure in any of the following cases:

- Mechanical failure.
- Handling failure.
- Lost component.

6.4 FAILED COMPONENTS

A component shall be considered as a failed component if it exhibits one or more of the failure modes described in Para. 6.3 of this specification.

6.5 LOT FAILURE

In the case of lot failure, the Manufacturer shall act in accordance with the requirements of Para. 4.3.1 of this specification.

6.5.1 Lot Failure during 100% Testing

If the number of components (when contacts are mounted in connectors the failure criteria refer to contacts), failed on the basis of the failure criteria described in Para. 6.3 is greater than 10% (rounded upwards to the nearest whole number), the lot shall be considered as failed.

A lot is composed of groups of components of the same technology as defined in the Detail Specification manufactured under the same conditions and at the same time.

6.5.2 Lot Failure during Sample Testing

A lot shall be considered as failed if the number of allowable failures during sample testing in accordance with General Inspection Level I of IEC Publication No. 410 and the applicable AQL, as specified in the Detail Specification, is exceeded.

If lot failure occurs in either case, 100% testing may be performed with the lot failure criteria given in Para. 6.5.1.

6.6 DOCUMENTATION

Documentation of final production test data shall be in accordance with Para. 10.6 of this specification.

7 BURN-IN AND ELECTRICAL MEASUREMENTS (CHART III)

Not applicable.

8 QUALIFICATION APPROVAL AND LOT ACCEPTANCE TESTS

8.1 QUALIFICATION TESTING

8.1.1 General

Qualification testing shall be in accordance with the requirements of Chart IV of this specification. The tests to Chart IV shall be performed on the specified sample, chosen at random from components which have successively passed the tests in Chart II. This sample constitutes the qualification test lot.

The qualification test lot is divided into subgroups of tests and all components assigned to a subgroup shall be subjected to all of the tests in that subgroup, in the sequence shown.

The applicable test requirements are detailed in the paragraphs referenced in Chart IV. Components shall be serialised prior to Chart IV testing.

The conditions governing qualification testing are given in ESCC Basic Specification No. 20100, Para. 5.3, and for the extension or renewal of qualification approval in Paras. 6.3 and 6.4.

8.1.2 Distribution within the Qualification Test Lot

A sample of 16 mated connector sets and 70 contact pairs for solder and PCB contacts, and 35 contact pairs for other termination types, shall be submitted to qualification testing (Chart IV). The distribution within the sample shall be as follows:

The connectors selected for qualification testing shall be representative of the range and termination types to be qualified and include at least the minimum and maximum sizes. If more than one contact size is present in the insert, then the connector with the smallest contact size shall be tested. Where the Detail Specification defines a range of permissible residual magnetism, connectors with the lowest residual magnetism for which qualification is sought shall be tested. Where there is the option of guiding and/or locking devices in the range to be qualified, locking devices shall be tested.

To qualify a connector family with a hermetic version, half the quantity of receptacles shall be hermetic.

Half of the sample shall be equipped with male contacts and half with female contacts, except for hermetic receptacles which shall always be equipped with male contacts.

The contact sets selected for qualification testing shall represent the range of contacts (size and termination) to be used in the connector series being qualified.

The selected distribution shall be agreed with the ESCC Executive.

8.2 LOT ACCEPTANCE TESTING

8.2.1 General

The sample sizes of the 3 lot acceptance levels are specified in Chart V. All components assigned to a subgroup shall be subjected to all of the tests of that subgroup in the sequence shown.

The tests to Chart V shall be performed on the specified sample which shall have been chosen, whenever possible, at random from the proposed delivery lot. The applicable test requirements are detailed in the paragraphs referenced in Chart V.

As a minimum for procurement of non-qualified components, lot acceptance level 3 tests shall apply. For procurement of qualified components, lot acceptance testing shall be performed if specified in a purchase order. Procurement lots ordered with a lot acceptance test level shall be delivered only after successful completion of lot acceptance testing.

8.2.2 Distribution within the Sample Lot for Lot Acceptance Testing

Where a Detail Specification covers a range, or series, of components that are considered similar, then it may be necessary that the sample for lot acceptance testing be comprised of component types so selected that they adequately represent all of the various mechanical, structural and electric Peculiarities of that range or series.

The distribution of the component types will normally vary from procurement to procurement and shall be specified by the Orderer, following as closely as possible the requirements specified in Para. 8.1.2 of this specification.

8.2.3 Lot Acceptance Level 3 Testing (LA3)

No tests or inspections are required for this level.

8.2.4 Lot Acceptance Level 2 Testing (LA2)

Lot acceptance level 2 testing shall comprise the tests on an endurance subgroup. For the endurance subgroup, the following shall apply:

- (a) Components, selected for the endurance subgroup, shall be serialised prior to the tests.
- (b) The tests in this subgroup are considered destructive and therefore components so tested shall not form part of the delivery lot.

8.2.5 Lot Acceptance Level 1 Testing (LA1)

Lot acceptance level 1 testing shall comprise the tests for LA2 (endurance subgroup) plus tests on an environmental and mechanical subgroup.

For the endurance subgroup, the requirements and conditions for LA2 (see Para. 8.2.4) shall apply.

For the environmental and mechanical subgroup, the following shall apply:

- (a) Components, selected for the environmental and mechanical subgroup, shall be serialised prior to the tests.
- (b) The tests in this subgroup are considered to be destructive and therefore components so tested shall not form part of the delivery lot.

8.3 FAILURE CRITERIA

The following criteria shall apply to qualification testing and to lot acceptance testing.

8.3.1 Environmental and Mechanical Test Failures

The following shall be counted as component failures:

- (a) Components which fail during tests for which the pass/fail criteria are inherent in the test method, e.g. solderability, etc.

8.3.2 Electrical Failures

The following shall be counted as component failures:

- (a) Components which, when subjected to electrical measurement on completion of environmental tests, in accordance with either Table 2 or Table 6, as specified in the Detail Specification, fail one or more of the applicable limits.
- (b) Components which, when subjected to electrical measurement at intermediate and end-points during endurance testing, in accordance with Table 6 of the Detail Specification, fail one or more of the applicable limits.
- (c) Components which, when subjected to measurement of electrical characteristics, in accordance with Table 2 of the Detail Specification, fail one or more of the applicable limits.

8.3.3 Other Failures

The following additional failures may also occur during qualification testing or lot acceptance testing:

- (a) Components failing to comply with the requirements of ESCC Basic Specification No. 20500.
- (b) Lost components.

8.4 FAILED COMPONENTS

A component shall be considered as failed if it exhibits one or more of the failure modes detailed in Para. 8.3 of this specification. The allowable number of failed components per subgroup, the aggregate failure constraints and the permitted distribution of such failures are shown at the foot of Charts IV and V of this specification.

When requested by the ESCC Executive or the Orderer, failure analysis of failed components shall be performed by the Manufacturer and the results provided.

Failed components from successful lots shall be marked as such and be stored at the Manufacturer's plant for 24 months.

8.5 LOT FAILURE

A lot shall be considered as failed if the allowable number of failures according to Chart IV or V of this specification, as relevant, has been exceeded.

In the case of lot failure, the Manufacturer shall act in accordance with Para. 4.3.1 of this specification.

8.6 DOCUMENTATION

For qualification testing, the qualification test data shall be documented in accordance with the requirements of Para. 10.8 of this specification.

In the case of lot acceptance testing, the data shall be documented in accordance with the requirements of Para. 10.9 of this specification.

CHART II(a) – FINAL PRODUCTION TESTS FOR CONNECTORS WITH REMOVABLE CONTACTS (1)

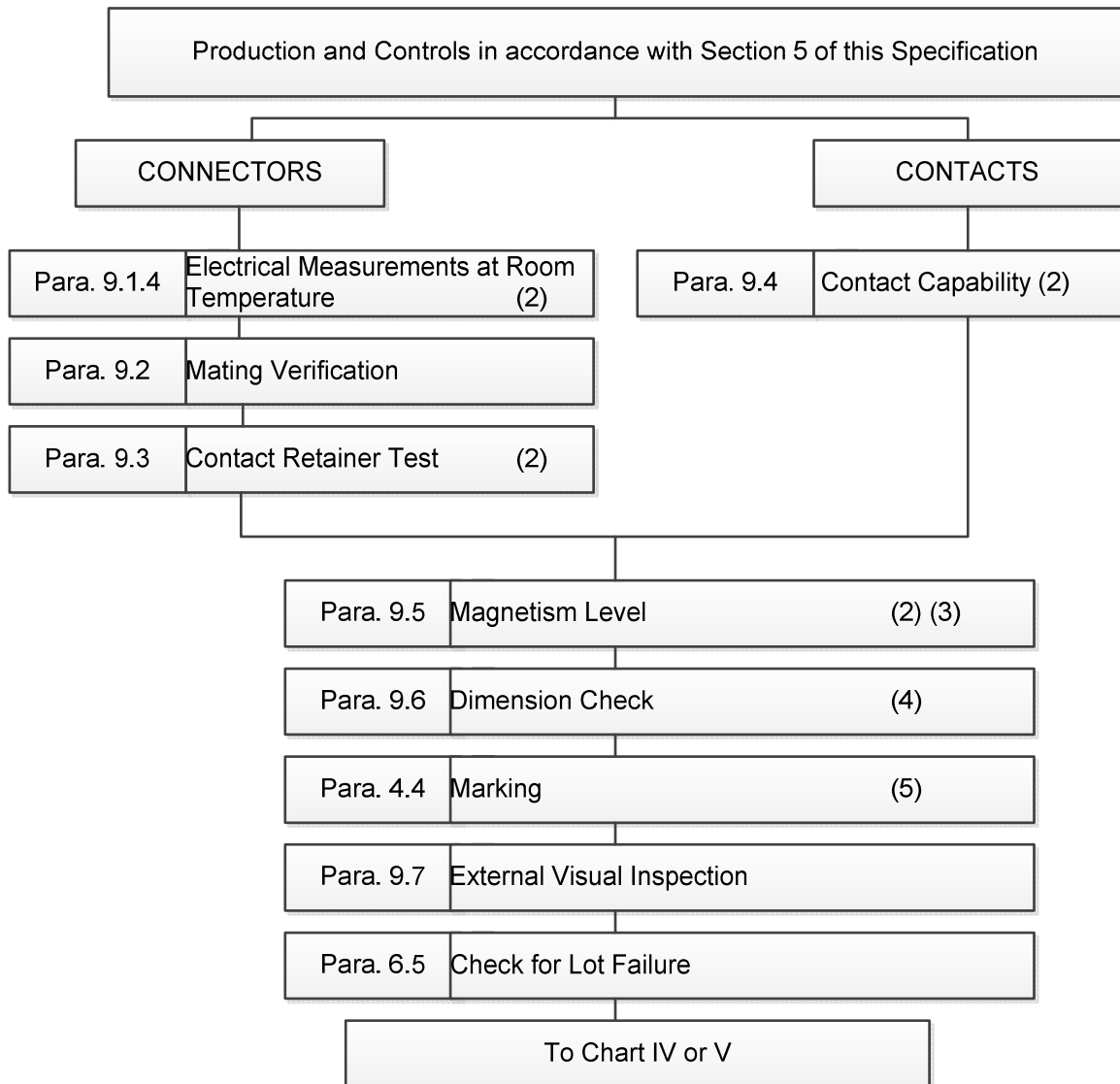

NOTES

1. For inserts accepting removable and non-removable contacts apply Charts II(a) and II(b), as applicable.
2. These tests do not have to be repeated if performed as part of the Manufacturer's standard process. If they are not repeated, the results shall be considered for PDA.
3. Unless otherwise specified in the Detail Specification.
4. These tests do not have to be repeated if performed as part of the Manufacturer's standard process. The results shall not be counted for PDA.
5. Marking may be performed at any place in the test sequence.

CHART II(b) - FINAL PRODUCTION TESTS FOR CONNECTORS WITH NON-REMOVABLE CONTACTS (1)

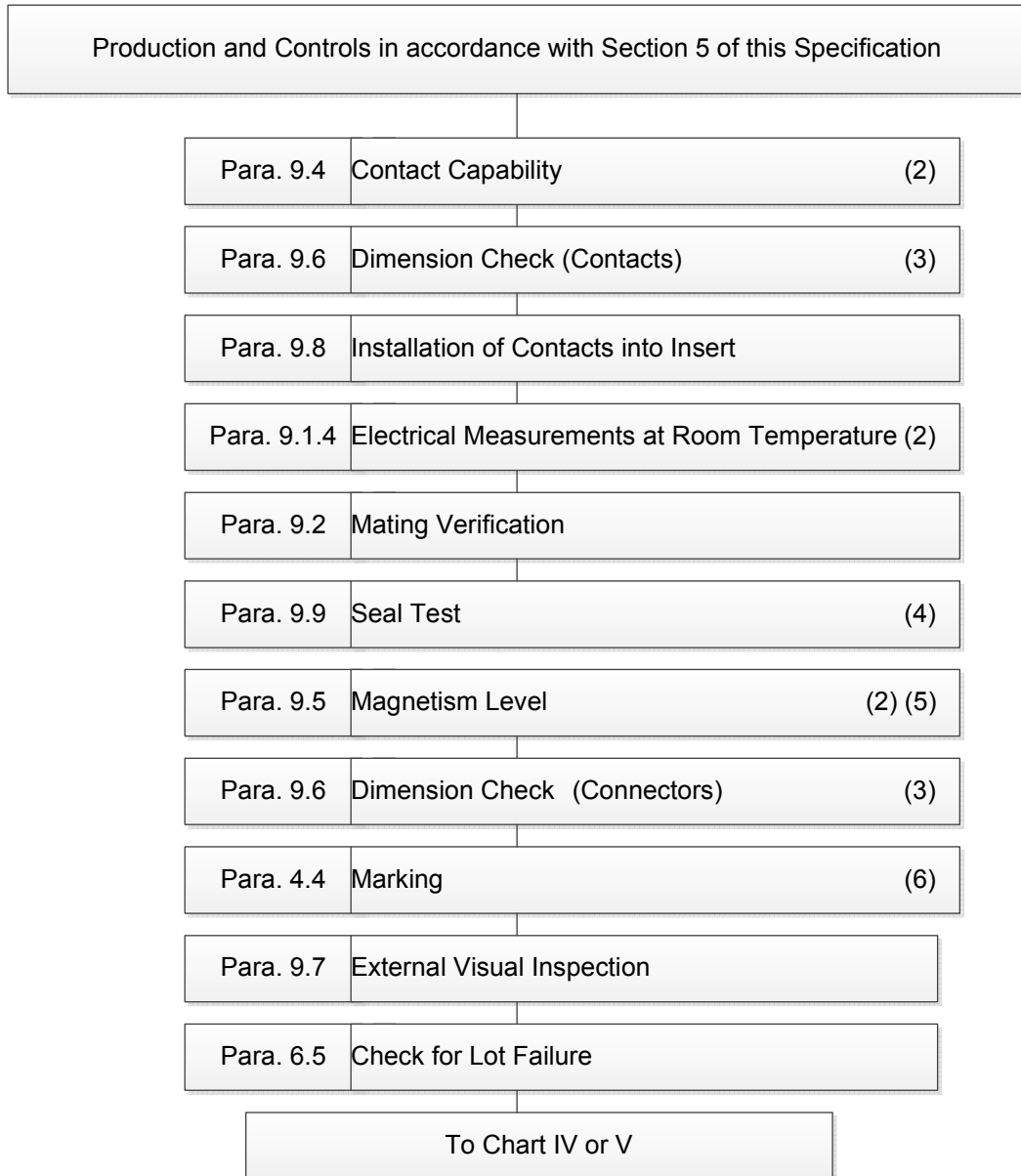

NOTES

1. For inserts accepting removable and non-removable contacts apply Charts II(a) and II(b), as applicable.
2. These tests do not have to be repeated if performed as part of the Manufacturer's standard process. If they are not repeated, the results shall be considered for PDA.
3. These tests do not have to be repeated if performed as part of the Manufacturer's standard process. The results shall not be counted for PDA.
4. Hermetic Connectors only.
5. Unless otherwise specified in the Detail Specification.
6. Marking may be performed at any place in the test sequence.

CHART III - BURN-IN AND ELECTRICAL MEASUREMENTS

Not applicable

CHART IV- QUALIFICATION TESTS

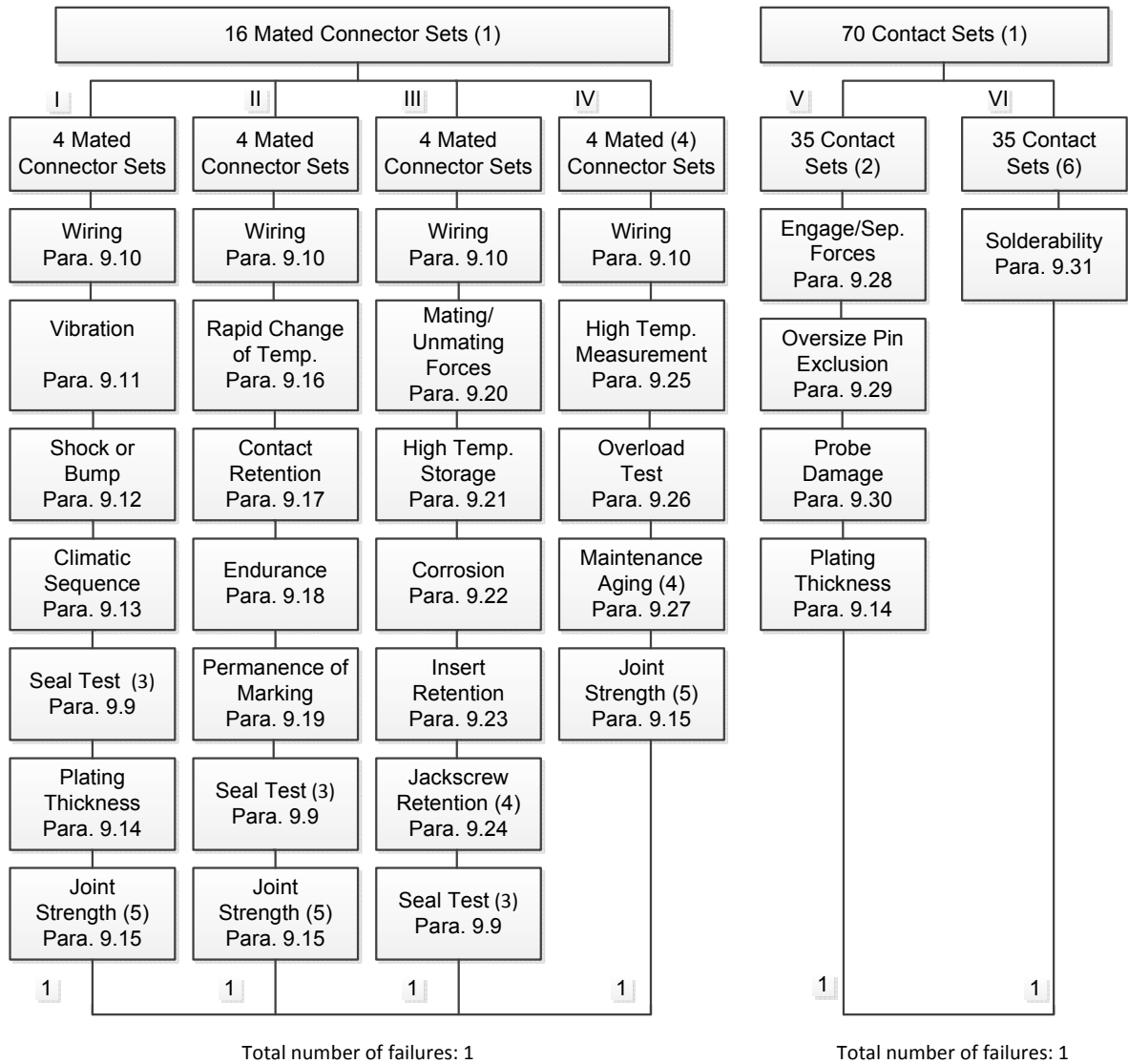

NOTES

1. For distribution within the subgroups, see Para. 8.1.2.
2. Subgroup V shall be repeated for each variation of female contact engagement end (functional part) technology.
3. Hermetic connectors only.
4. Unless otherwise specified in the Detail Specification.
5. Failures from this test to be counted with the failures from Subgroups V and VI.
6. Contacts with solder and PC terminations only.

CHART V- LOT ACCEPTANCE TESTS

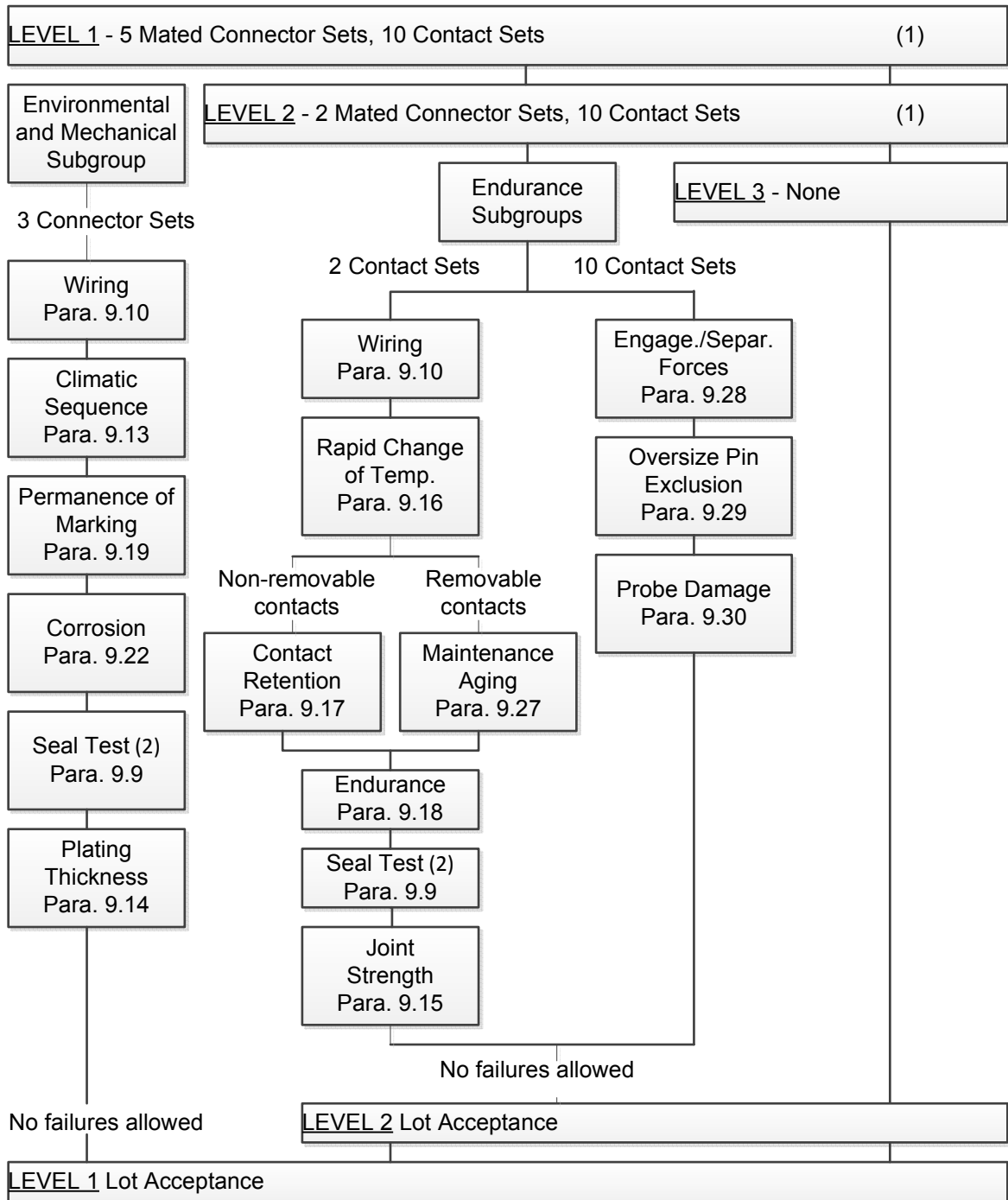

NOTES

1. For distribution within the sample, see Para. 8.2.2.
2. Hermetic connectors only.

9 TEST METHODS AND PROCEDURES

If a Manufacturer elects to eliminate or modify a test method or procedure, the Manufacturer is still responsible for delivering components that meet all of the performance, quality and reliability requirements defined in this specification and the Detail Specification.

Documentation supporting the change shall be approved by the ESCC Executive and retained by the Manufacturer. It shall be copied, when requested, to the ESCC Executive.

The change shall be specified in the Detail Specification and in the PID.

9.1 ELECTRICAL MEASUREMENTS

9.1.1 Electrical Test Methods

9.1.1.1 *Insulation Resistance*

(a) *Applicability*

This test shall be performed 100% on connectors with sandwich construction inserts.

Connectors with monobloc inserts shall be sample tested, 10%, or 2 whichever is greater; if 1 failure occurs, the test shall be performed 100%.

(b) *Procedure*

The insulation resistance shall be measured between each contact in turn and all remaining contacts connected together and to the shell (if any) in accordance with IEC Publication 512-2, Test 3a, Method A (circular connectors) or Method 8 (rectangular connectors), using a voltage of $500 \pm 50V$, on unmated connectors. The measurement results shall exceed the values specified in the Detail Specification.

Dummy contacts may be used (metallic parts with overall dimensions identical to those of the contacts without retention system).

9.1.1.2 *Voltage Proof (Sea Level)*

(a) *Applicability*

This test shall be performed 100% on connectors with sandwich construction inserts.

Connectors with monobloc inserts shall be sample tested, 10%, or 2 whichever is greater; if 1 failure occurs, the test shall be performed 100%.

(b) *Procedure*

The voltage proof test shall be performed on unmated connectors between each contact in turn and all remaining contacts connected together and to the shell (if any) in accordance with IEC Publication 512-2, Test 4a, Method A (circular connectors) or Method 8 (rectangular connectors) under standard conditions. The test voltage shall be as specified in the Detail Specification and it shall be applied for 5 seconds minimum for final production tests and 1 minute minimum for qualification and lot acceptance tests.

Dummy contacts may be used (metallic parts with overall dimensions identical to those of the contacts without retention system).

9.1.1.3 Contact Resistance

(a) Definition

Contact Resistance (R_C) at low level and rated current is defined in Figures I(a) and I(b) as follows:

(i) Figure I(a)

For contacts inaccessible from the rear:

Measurements shall be performed on the wires. R_C shall be calculated by deduction from the actually measured ohmic resistance values of the wires (total length: $2 \times 'L'$).

(ii) Figure I(b)

For contacts accessible from the rear:

R_C shall be measured at the emergence of the contact rear part from the insert.

Contact resistance may be measured by either the DC or the AC method. In case of dispute the DC method shall govern.

(b) Test Conditions

Test samples may be installed in a suitable connector and engaged as for normal service.

Samples that are not installed in a connector shall be rigidly fixed by any method which does not influence the forces acting on the interface between the mating contacts.

(i) Low Level Current

DC method:

- Maximum Potential Across Sample: 20mV
- Maximum Applied Current: 10mA

Two measurements shall be performed with opposite polarity. The average of the two readings shall be considered as indicative of the low level resistance value. R_C shall be expressed in milliohms.

AC method:

- Maximum Potential Across Sample: 20mVrms
- Maximum Measuring Frequency: 2kHz
- Maximum Applied Current: 10mArms

R_C shall be expressed in milliohms.

(ii) Rated Current

The test shall not be performed until thermal stability has been achieved. Thermal stability will have been reached when no change in resistance is observed between 2 successive measurements taken at 15 minutes interval.

DC method:

- Potential Across Sample: from 1V to 60V
- Maximum Applied Current: as specified in the Detail Specification

Two measurements shall be performed with opposite polarity. The average of the two readings shall be considered as indicative of the resistance value. R_C shall be expressed in milliohms.

AC method:

- Potential Across Sample: from 1V to 60Vrms
- Maximum Applied Current: as specified in the Detail Specification (rms)
- Maximum Measuring Frequency: 2kHz

R_C shall be expressed in milliohms.

(c) Sampling

This sampling is applicable only to measurements of contacts mounted in connectors.

- Number of contacts in connector equal to, or less than, 4: Measure all contacts.
- Number of contacts in connector more than 4: Measure 20% of the contacts, but not less than 4 contacts.

FIGURE I - CONTACT RESISTANCE MEASUREMENT DIAGRAM

FIGURE I(a) - CONTACTS INACCESSIBLE FROM THE REAR

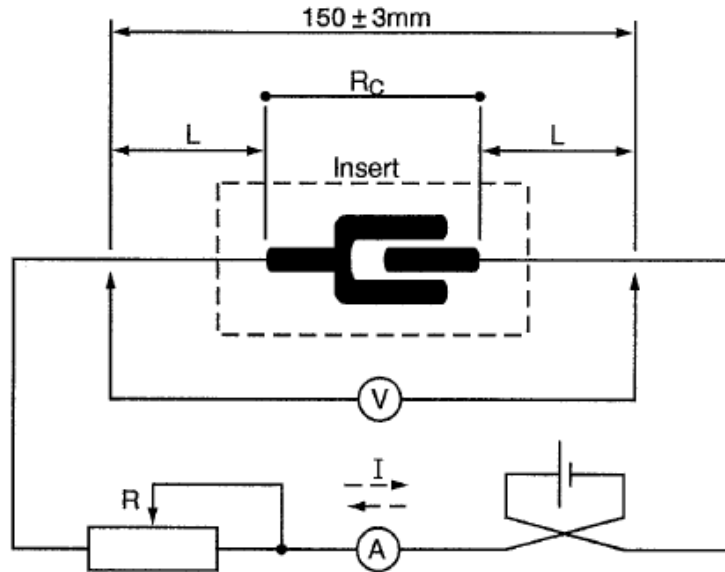
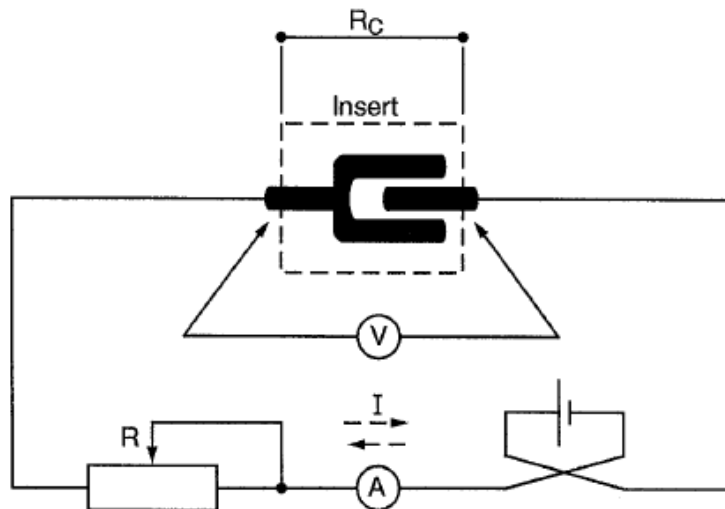

FIGURE I(b) - CONTACTS ACCESSIBLE FROM THE REAR



9.1.1.4 Mated Shell Conductivity

(a) Test Conditions

Unless otherwise specified in the Detail Specification, a test current of $1 \pm 0.1\text{A}$ (DC or AC rms) at a maximum voltage of 1.5V (DC or AC rms), shall be used.

(b) Procedure

The resistance of the mated, assembled connectors shall be measured from a point on the rear accessory thread (or body, if no thread is present) of the plug to the mounting flange of the receptacle.

The point of measurement on a square flange receptacle shall be adjacent to the mounting holes.

The point of measurement on a single hole mount receptacle shall be adjacent to the "0" ring on the front or mounting side of the flange.

Probes with spherical ends of 0.13mm minimum radius shall be used to make the measurements.

9.1.1.5 *VSWR*

In accordance with ESCC Generic Specification No. 3402, Para. 9.16.

9.1.1.6 *Insertion Loss*

In accordance with ESCC Generic Specification No. 3402, Para. 9.19.

9.1.2 Parameter Drift Value Measurements

Not applicable.

9.1.3 Electrical Measurements at High and Low Temperatures

Not applicable.

9.1.4 Electrical Measurements at Room Temperature

The measurements of electrical characteristics shall be made in accordance with Table 2 of the Detail Specification.

9.1.5 Electrical Measurements during Endurance Testing

At each of the relevant data points specified for endurance testing, measurements shall be made of all parameters listed in Table 6 of the Detail Specification. All values obtained shall be recorded against serial numbers.

9.2 MATING VERIFICATION

The connectors shall be mated and unmated once with their counterparts to verify the proper functioning of the coupling mechanism.

9.3 CONTACT RETAINER TEST

9.3.1 Applicability

This test is applicable only to connectors with removable contacts when the contact retaining clip is situated within the insert.

9.3.2 Procedure

A contact or special gauge shall be inserted successively into each contact cavity, verified manually for positive retention, then released and removed. If the contact or gauge cannot be inserted manually, or if there is no retention, the connector shall be rejected.

9.4 CONTACT CAPABILITY

(a) Applicability

This test is applicable to female contacts or to male contacts where the male contact deforms to make and retain electrical contact.

(b) Procedure

The contacts shall pick up the minimum weight and drop the maximum weight. These weights shall be as specified in the Detail Specification.

9.5 MAGNETISM LEVEL

The contacts shall be installed in the connectors before testing, or placed next to the connectors, and the test shall be performed in a magnetically quiet area, i.e. where machines, electronic equipment, vehicles and personnel traffic are restricted. The procedure shall be as follows:

(a) Warm up the milli-oerstedmeter for the appropriate period.

(b) Mount the probe in the non-magnetic stand in a horizontal position at full cable length from the meter.

(c) Preset the meter to the appropriate scale; orient the probe to obtain a zero reading on the meter.

(d) Pass the connector specimen 3 times inside a magnetic field with field strength of approximately 5000Gauss (the connector shall not contact the coil, if a coil is used).

(e) Immediately place the connector to within 3mm of the probe tip, unless otherwise specified in the Detail Specification, and orient the specimen for a maximum reading (the measurement units shall be in gamma, 1 gamma being equivalent to 1×10^{-5} Gauss).

(f) The reading shall meet the applicable requirements of the Detail Specification.

N.B. In case of conflict, the method with contacts installed in the connectors shall govern.

9.6 DIMENSION CHECK

In accordance with ESCC Basic Specification No. 20500 and the Detail Specification, on 3 connectors or accessories, and in accordance with the table below for contacts.

If a failure occurs, the complete lot shall be checked.

Lot Size	Sampling
2 to 15	2
16 to 25	3
26 to 90	5
91 to 150	8
151 to 280	13
281 to 500	20
501 to 1200	32
1201 to 3200	50
3201 to 10000	80

9.7 EXTERNAL VISUAL INSPECTION

In accordance with ESCC Basic Specification No. 20500. In the case of sampling, if a failure occurs, the complete lot shall be checked.

9.8 INSTALLATION OF CONTACTS INTO INSERT

In accordance with the Process Identification Document (PID).

9.9 SEAL TEST

(a) Applicability

This test is only applicable to hermetically sealed connectors.

(b) Procedure

The leakage rate shall not exceed 10^{-8} cubic centimetres per second of helium under a vacuum of 10^{-5} Torr.

9.10 WIRING

9.10.1 Solder Contacts

(a) Choice of Wire

The wire shall be of the minimum and maximum gauge that the solder bucket is designed to accept. The insulation shall be capable of surviving, without any degradation in performance, the same maximum temperature as the connector. Additionally, ESA PSS-01-708 shall be used to aid the selection of wire.

(b) Attachment of Wire

For hermetic connectors, a solderability test (Para. 9.31) shall be performed before wire attachment. The wires shall be soldered to the contacts, as closely as practicably, in accordance with the requirements of ESA PSS-01-708. Half of the contacts shall be equipped with wire of the maximum gauge and half with the minimum gauge.

(c) Inspection of Soldered Joints

The soldered joints shall be examined in accordance with, and meet the requirements of, the visual inspection criteria of ESA PSS-01-708.

(d) Electrical Measurements (Chart IV only)

For connectors in Subgroups I, II and IV, the low level contact resistance (all points) shall be measured and shall not exceed the value specified in the Detail Specification.

9.10.2 Crimp Contacts

(a) Choice of Wire

The wire shall be of the minimum and maximum gauge that the crimping barrel is designed to accept. The wire shall have a greater tensile strength than the ultimate axial strength required of the crimped joint. The insulation shall be capable of surviving, without any degradation in performance, the same maximum temperature as the connector. Additionally, ESA PSS-01-726 shall be used to aid the selection of wire.

(b) Attachment of Wire

The wires shall be crimped to the contacts, as closely as practicably, in accordance with the requirements of ESA PSS-01-726. Half of the contacts shall be equipped with wire of the maximum gauge and half with the minimum gauge.

(c) Inspection of Crimped Joints

The crimped joints shall be examined in accordance with, and meet the requirements of, the visual inspection criteria of ESA PSS-01-726.

(d) Electrical Measurements (Chart IV only)

- (e) The voltage drop across each crimped joint shall be measured as specified in ESA PSS-01-726 and shall not exceed the requirements specified therein. For connectors in Subgroups I, II and IV, the low level contact resistance (all points) shall be measured and shall not exceed the value specified in the Detail Specification.

9.10.3 Wire-Wrap Contacts

- (a) Choice of Wire

The wire shall be of the minimum and maximum gauge that the wrap post is designed to accept. The wire shall have a greater tensile strength than the ultimate axial strength required of the wrapped joint. The insulation shall be capable of surviving, without any degradation in performance, the same maximum temperature as the connector. Additionally, ESA PSS-01-730 shall be used to aid the selection of wire.
- (b) Attachment of Wire

The wires shall be wrapped to the contacts, as closely as practicably, in accordance with the requirements of ESA PSS-01-730. Half of the contacts shall be equipped with wire of the maximum gauge and half with the minimum gauge.
- (c) Inspection of Wrapped Joints

The wrapped joints shall be examined in accordance with, and meet the requirements of, the visual inspection criteria of ESA PSS-01-730.
- (d) Electrical Measurements (Chart IV only)

The connection resistance (all points) shall be measured as specified in ESA PSS-01-730 and shall not exceed the requirements specified therein. For connectors in Subgroups I, II and IV, the low level contact resistance (all points) shall be measured and shall not exceed the value specified in the Detail Specification.

9.11 VIBRATION

9.11.1 General

The connectors shall be subjected to Sinusoidal Vibration Testing (see Para 9.11.2) and Random Vibration Testing (see Para. 9.11.3). Only one half of the connector set shall be fixed to the vibration table. The two halves of the connector shall be secured together by means of their standard locking devices. The order of performance of the tests shall be at the discretion of the Manufacturer.

- (a) Method of Mounting

Mated, wired connector sets shall be mounted on the vibration table by their normal mounting means or by a suitable clamping arrangement. For PCB connectors, either the plug or the receptacle shall be mounted on the vibration table by its own printed circuit board. The wires shall be clamped to a non-vibrating point which is at least 20cm away from the connectors such that resonance of the wires is avoided. The screw(s) of connectors with a screw coupling mechanism shall be torqued and released 50 times to the value specified in the Detail Specification and the unlocking torque shall be recorded on the last operation.
- (b) Measurement during Vibration

The series-wired contacts shall be monitored as specified in IEC Publication No. 512-2, Test 2e, with a maximum contact disturbance time of 1 μ s.

- (c) Examination after Testing
Mated connector sets shall be retained in full engagement. Screw unlocking torque shall be measured and the drift with respect to the value recorded before the start of the test shall meet the requirements of Table 6 of the Detail Specification. Connectors, accessories and locking devices, as applicable, shall not be damaged and there shall be no loosening of parts caused by vibration.

9.11.2 Sinusoidal Vibration Testing

The connectors shall be submitted to vibration testing in accordance with IEC Publication No. 512-4, Test 6d. Sweep frequency: 10-2000-10Hz. The entire frequency range of 10 to 2000Hz and return to 10Hz shall be traversed in 30 minutes. The vibration amplitude shall be 1.5mm or 20g whichever is less. This cycle shall be performed once in each of the 3 mutually perpendicular directions so that the motion is applied for a total period of approximately 90 minutes.

9.11.3 Random Vibration Testing

The connectors shall be submitted to random vibration testing in accordance with IEC Publication No. 68-2-35, test Fda with $f_1 = 20\text{Hz}$, $f_2 = 2000\text{Hz}$, an Acceleration Spectral Density (ASD) of $0.2\text{g}^2/\text{Hz}$, a total test period of 30 minutes and high reproducibility. This cycle shall be performed once in each of the 3 mutually perpendicular directions so that the motion is applied for a total period of approximately 90 minutes.

9.12 SHOCK OR BUMP

9.12.1 Shock

The connectors shall be submitted to mechanical shock in accordance with IEC Publication No. 512-4, Test 6c. Shape of shock pulse: half-sine. A peak acceleration of 50g with an 11ms duration pulse shall be used. 3 shocks in each direction along the 3 mutually perpendicular directions (i.e. 18 in total) shall be applied.

- (a) Method of Mounting
As per Para. 9.11.1(a), the word 'vibration' to be replaced by 'shock'. The screw coupling torquing and releasing shall not be repeated.
- (b) Measurement during Shock
As per Para. 9.11.1(b).
- (c) Examination after Testing
As per Para. 9.11.1(c), the word 'vibration' to be replaced by 'shock'.

9.12.2 Bump

The connectors shall be submitted to bump in accordance with IEC Publication No. 512-4, Test 6b. Peak acceleration: 390m/s^2 . Number of bumps: 4000 ± 10 .

- (a) Method of Mounting
As per Para. 9.11.1(a), the word 'vibration' to be replaced by 'bump'. The screw coupling torquing and releasing shall not be repeated.
- (b) Measurement during Bump
As per Para. 9.11.1(b).
- (c) Examination after Testing
As per Para. 9.11.1(c), the word 'vibration' to be replaced by 'bump'.

9.13 CLIMATIC SEQUENCE

9.13.1 Initial Measurements

None.

9.13.2 Dry Heat

The mated connectors shall be subjected to Test 'Ba' of IEC Publication No. 68-2-2. Duration: 2 hours. Maximum operating temperature as prescribed in Table 1(b) of the Detail Specification.

While still at the specified high temperature and at the end of the period of high temperature, Insulation Resistance shall be measured as specified in Table 6 of the Detail Specification and the values shall be within the specified limits.

9.13.3 Damp Heat, Accelerated, First Cycle

Unless otherwise specified in the Detail Specification, the mated connectors shall be subjected to Test 'Db', severity b, variant 2 of IEC Publication No. 68-2-30, 1 cycle. After recovery, the components shall be subjected immediately to the cold test.

9.13.4 Cold Test

The mated connectors shall be subjected to Test 'Aa' of IEC Publication No. 68-2-1. Duration: 2 hours. Minimum storage temperature as specified in Table 1(b) of the Detail Specification.

9.13.5 Low Air Pressure

The components shall be subjected to Test 'M' of IEC Publication No. 68-2-13 under the following conditions:

- Half the number of connectors shall be mated, the other half unmated.
- Simulated altitude: 33000m, as defined in Figure 1 of the Detail Specification.
- Temperature: $T_{amb} = +15$ to $+35^{\circ}\text{C}$.

After 10 minutes at the specified (simulated) altitude the applied voltage shall be raised from zero to the maximum voltage defined in Table 6 of the Detail Specification at, as uniformly as possible, a rate of 50Volts/second. Upon reaching the maximum voltage defined in Table 6 of the Detail Specification, it shall be maintained at that value for 1 minute. During that time the connectors shall be monitored for evidence of electrical breakdown, flashover, corona discharge, or current leakage in excess of 1mA.

9.13.6 Damp Heat, Accelerated, Remaining Cycles

The mated connectors shall be subjected to Test 'Db', severity B, variant 2 of IEC Publication No. 68-2-30, 5 cycles. Immediately after the test the Insulation Resistance shall be measured as specified in Table 6 of the Detail Specification and the value shall be within the specified limits.

9.13.7 Recovery and Final Inspection

After a recovery period of 1 to 24 hours, the components shall be visually inspected according to ESCC Basic Specification No. 20500.

9.13.8 Final Measurements

Insulation Resistance and Voltage Proof shall be measured and shall meet the requirements of Table 6 of the Detail Specification.

9.14 PLATING THICKNESS

The test shall be performed as specified in Para. 5.2.3 of this specification.

9.15 JOINT STRENGTH

9.15.1 Applicability

This test is not applicable to solder contacts.

9.15.2 General Procedure

Removable contacts shall be removed from the insert prior to testing. Non-removable contacts shall be tested in the insert. Should the contact come out of the insert before the specified force is reached, the test shall be continued as for removable contacts. The test shall be performed on 5, or all (whichever is less) contacts from each connector.

9.15.3 Crimp Contacts

The contacts shall be subjected to, and shall meet the requirements of, the tensile test in accordance with ESA PSS-01-726.

9.15.4 Wire-Wrap Contacts

The contacts shall be divided into two groups. Half shall be subjected to the tensile strength test and half to the rewinding test.

(a) Tensile Strength Test

The contacts shall be subjected to, and shall meet the requirements of, the test in accordance with ESA PSS-01-730.

(b) Rewinding Test

The wrapped connections shall be unwrapped in accordance with ESA PSS-01-730. Fresh wires shall be wrapped onto the posts in accordance with Para. 9.10.3(b). The new wrapped connections shall meet the requirements of the gas tightness test in accordance with ESA PSS-01-730.

9.15.5 Coaxial Contacts

This test is not applicable to contacts designed to accept semi-rigid cable.

(a) The contact and cable shall be firmly fixed and a sleeve or equivalent attached to the cable. The sleeve shall then be moved away from the fixed contact longitudinally and gradually, and in such a manner that the cable remains unbent and untwisted. A scale for measuring the retention force shall be attached to the sleeve. The force, as specified in the Detail Specification, shall be maintained for 30 seconds minimum.

(b) The assembly, still under tension, shall be tested for contact resistance (inner and outer contacts) and shall then be examined for mechanical failure, loosening or rupture.

(c) With the contact still in the fixed position, the cable shall be held at a point 50 times the diameter of the cable from the contact and a torque shall be applied in both directions up to an angle of 90°.

(d) The cable shall then be bent at a radius of 10 times the diameter of the cable, starting at the contact, at an angle of $90 \pm 5^\circ$ from the axis of the contact, then reversed $180 \pm 10^\circ$.

This procedure shall be repeated 4 times prior to retest and re-examination as specified in (b) above.

9.16 RAPID CHANGE OF TEMPERATURE

(a) Procedure

The wired, mated connector sets shall be subjected to 5 cycles of the test in accordance with IEC Publication 512-6, Test 11d. Alternatively, the test in accordance with IEC Publication 68-2-14, Test Nb may be used, with temperature extremes as defined in steps 1 and 3 below. The chamber shall be capable of a transfer time of no more than 5 minutes between the temperature extremes and 5 cycles shall be performed. The following steps shall be used:

1. Minimum Storage Temperature as defined in Table 1(b) of the Detail Specification: 30 minutes.
2. $T_{amb} = +25 (+10 -5)^{\circ}\text{C}$: 5 minutes (max.).
3. Maximum Storage Temperature as defined in Table 1(b) of the Detail Specification: 30 minutes.
4. $T_{amb} = +25 (+10 -5)^{\circ}\text{C}$: 5 minutes (max.).

(b) Final Inspection

The components shall be visually examined. There shall be no damage detrimental to the operation of the connectors.

(c) Final Measurements

Insulation Resistance and Voltage Proof shall be measured and shall meet the requirements of Table 6 of the Detail Specification.

9.17 CONTACT RETENTION (IN INSERT)

9.17.1 General

The connectors shall have all contacts in place and the accessory rear hardware removed during the test. The force (compression for all contacts and tension additionally for contacts installed from the front) shall be applied to the engagement end of the contact either directly or by using an appropriate adaptor at a rate not exceeding 5N per second until the force specified in the Detail Specification is reached. This force shall be maintained for a minimum period of 5 seconds. A minimum of 20%, but not less than 5 of the contacts in each connector, shall be tested.

9.17.2 Non-removable Contacts

The connectors shall be tested as specified in Para. 9.17.1. The axial displacement of the contact shall be measured after the force has been removed from the contact and shall not exceed 0.3mm.

9.17.3 Removable Contacts

The connectors shall be tested as specified in Para. 9.17.1 except that an initial force of 10N shall be applied to ensure that the contact float has been taken up before measuring contact displacement. Displacement shall then be measured from the insert face with the contact under load and it shall not exceed 0.3mm.

9.18 ENDURANCE

(a) Initial Measurements

The mating-unmating forces, low level contact resistance (all points) and mated shell conductivity (if specified in the Detail Specification) shall be measured and shall meet the requirements of Table 6 of the Detail Specification.

- (b) Procedure
Mating, wired connector sets shall be mated and unmated 500 times for qualification (Chart IV) and 100 times for lot acceptance (Chart V). A cycle is defined as one mating and one unmating. The coupling means shall be operated in a manner to simulate actual service. The plug and receptacle shall be completely separated during each cycle. The mating/unmating speed shall be 5 mm/second maximum and the cycling rate shall be 8 cycles/minute maximum.
- (c) Final Inspection
The components shall be visually examined, except for contact wear, the connectors shall show no evidence of physical damage.
- (d) Final Measurements
Cleaning of the connectors is not permitted before any electrical measurements.

After a recovery period of 2 hours minimum, the mating-unmating forces, the drift of low level contact resistance, mated shell conductivity (if specified in the Detail Specification), insulation resistance and voltage proof shall be measured and shall meet the requirements of Table 6 of the Detail Specification.

9.19 PERMANENCE OF MARKING

- (a) Applicability
This test is not applicable to stamped or engraved components.
- (b) Procedure
In accordance with ESCC Basic Specification No. 24800.

9.20 MATING AND UNMATING FORCES

The connectors with wired contacts installed shall be mated and unmated four times with force applied gradually and distributed equally about the connector. The mating and unmating forces shall be measured on the first and last cycles and shall not exceed the requirements of the Detail Specification.

9.21 HIGH TEMPERATURE STORAGE

- (a) Initial Measurements
The low level contact resistance (all points) and the mated shell conductivity (if specified in the Detail Specification) shall be measured and shall meet the requirements of Table 6 of the Detail Specification.
- (b) Procedure
The wired, mated connector sets shall be subjected to the test in accordance with IEC Publication No. 512-6, Test 11i, for 1000 hours. The temperature shall be the maximum storage temperature specified in Table 1(b) of the Detail Specification.
- (c) Final Inspection
The components shall be visually examined and shall show no evidence of physical damage.
- (d) Final Measurements
The mating-unmating forces, the drift of low level contact resistance, rated current contact resistance (all points), mated shell conductivity (if specified in the Detail Specification), insulation resistance and voltage proof shall be measured and shall meet the requirements of Table 6 of the Detail Specification.

The contacts shall be submitted to the contact retention test as specified in Para. 9.17.

9.22 CORROSION

(a) Applicability

This test is not applicable to PCB connector families where both parts are intended for PCB mounting.

(b) Procedure

Unmated connectors shall be subjected to the test in accordance with IEC Publication No. 68-2-11, Test Ka, for 48 hours. Connectors shall be suspended in the chamber in a horizontal position.

(c) Final Inspection

The connectors shall be visually examined, no base metal shall be exposed on the interfaces or mating surfaces.

9.23 INSERT RETENTION (IN SHELL)

9.23.1 Environment Resistant Connectors

Connector rear accessories, if applicable, shall be removed for this test. Inserts with or without contacts shall be submitted to axial loads in directions tending to push them out of the shell. Half of the devices shall be subjected to load applied from the front and half to load applied from the rear. The load shall be applied and increased gradually at an approximate rate of 0.7kg/cm^2 per second until the maximum load as specified in the Detail Specification is reached. The maximum load shall be maintained for 5 seconds. The portion of the load-applying device that touches the surface of the insert may be shaped to clear the contacts if installed, and any raised areas on the inserts (bosses, barriers or identifiers).

The connector inserts shall not be dislodged from their normal position within their shells.

9.23.2 Hermetic Connectors

Support the receptacle in a suitable hydrostatic testing apparatus that will allow the application of a hydrostatic pressure of 70N/cm^2 in either direction. Apply the pressure to the face, or front, of the receptacle and then to the rear. The insert shall not be displaced within the receptacle shell and the connector shall then meet the seal test requirements of Para. 9.9.

9.24 JACKSCREW RETENTION (CONNECTORS WITH A JACKSCREW)

An axial load shall be applied to the jackscrew from the end of the connector most likely to dislodge the jackscrew. The rate of increase of load, maximum load and period of maximum load application shall be as specified in the Detail Specification.

9.25 HIGH TEMPERATURE MEASUREMENTS

Unmated connectors shall be raised to the maximum operating temperature, as specified in Table 1(b) in the Detail Specification, for 30 minutes. At the end of that time, and while still at the specified high temperature, the insulation resistance shall be measured and shall meet the requirements of Table 6 of the Detail Specification.

9.26 OVERLOAD TEST

(a) Procedure

A current of 1.5 times the rated current specified in the Detail Specification for each contact size shall be passed through all contacts of mated connectors for a period of 30 seconds. This shall be followed by a period of 90 seconds with no current flowing. This shall constitute 1 cycle. The cycle shall be repeated 5 times (10 minutes total).

(b) Final Measurements

At the conclusion of the test, the internal temperature of the connectors, measured with a suitable sensing device, shall not exceed the value specified in Table 6 of the Detail Specification. A contact at, or near to, the centre of the insert may be replaced with the temperature sensing device.

After a recovery period of 1 to 2 hours, the rated current contact resistance (all points), mated shell conductivity (if specified in the Detail Specification), insulation resistance and voltage proof shall be measured and shall meet the requirements of Table 6 of the Detail Specification.

9.27 MAINTENANCE AGING (REMOVABLE CONTACTS ONLY)

(a) Procedure

20%, but not less than 5, randomly selected contacts shall be removed from the insert and reinserted once, using the Manufacturer's approved tools, exercising care to prevent damage to the insert or wire sealing grommet, if any. The insertion force of the contact into the insert shall not exceed the values specified in Table 6 of the Detail Specification. The number of cycles shall be 9.

(b) Final Inspection

The insert, or wire sealing grommet if any, shall be visually examined and shall show no evidence of physical damage.

(c) Final Measurements

The tested contacts shall be capable of passing the contact retention test of Para. 9.17 and the contact insertion and withdrawal forces shall be measured and shall meet the requirements of Table 6 of the Detail Specification.

9.28 ENGAGEMENT AND SEPARATION FORCES

(a) Applicability

As per Para. 9.4(a).

(b) Procedure

10, or all, whichever is less, of the contacts shall be tested as follows:

A gradually increasing force with displacement not exceeding 1mm/second shall be applied until the test pin, or sleeve, properly engages with, or separates from, the contact. The test pin, or sleeve, shall be made of hardened tool steel with a surface roughness of 0.1 to 0.25µm and a minimum hardness of 650 HV. Test pins shall have spherical ends. The diameter of the test pin, or sleeve, shall be as specified in the Detail Specification.

The maximum diameter test pin, or minimum diameter test sleeve, shall be engaged to 70% of the depth of the female mating cavity or length of the engagement end of a male contact, and then separated 3 times. The engagement and separation forces shall be measured on the third engagement and separation. Subsequently, the minimum diameter test pin, or maximum diameter test sleeve, shall be engaged and separated once to measure the separation force.

9.29 OVERSIZE PIN EXCLUSION

A hardened steel pin of the dimensions specified in the Detail Specification shall be placed in the centre of the female contact and parallel to its axis. A force as specified in the Detail Specification shall be applied, aimed at forcing the test pin into the female contact. The test pin shall not enter the female contact.

9.30 PROBE DAMAGE

Female contacts shall be submitted to the test in accordance with IEC Publication No. 512-8, Test 16a. The dimensions of the test pin and the bending moment to be applied shall be as specified in the Detail Specification. Subsequently, the contact separation force shall be measured with the minimum diameter test pin and shall meet the requirements of the Detail Specification.

9.31 SOLDERABILITY

9.31.1 Solder Contacts

The contacts shall be submitted to the test in accordance with IEC Publication No. 512-6, Test 12b. The size of soldering iron (A or B) shall be as specified in the Detail Specification.

9.31.2 PCB Contacts

The contacts shall be submitted to the test in accordance with IEC Publication No. 512-6, Test 12a. The contacts shall be immersed to a depth such that all of the termination is covered.

10 DATA DOCUMENTATION

10.1 GENERAL

For the qualification approval records and with each component delivery, a data documentation package is required. Depending on the testing level and lot acceptance level specified for the component, this package shall be compiled from:

- (a) Cover sheet (or sheets).
- (b) List of equipment (testing and measuring).
- (c) List of test references.
- (d) Special in-process control test data.
- (e) Final production test data (Chart II) (but see Para. 10.6).
- (f) Qualification test data (Chart IV).
- (g) Lot acceptance test data (Chart V) (when applicable).
- (h) Failed component list (see Para's. 6.4 and 8.4), and failure analysis report (see Para. 8.4).
- (i) Certificate of Conformity.

Items (a) to (i) inclusive shall be grouped, preferable as subpackages, and for identification purposes, each page shall include the following information:

- ESCC Component Number.
- Manufacturer's name.
- Lot identification.
- Date of establishment of the document.
- Page number.

10.1.1 Qualification Approval

In the case of qualification approval, the items listed in Para. 10.1(a) to (i) less item (g) are required.

10.1.2 Testing Level 'B'

10.1.2.1 *Qualified Components*

For deliveries of qualified components, the following documentation shall be supplied:

- (a) Cover sheet (if all of the information is not included on the Certificate of Conformity).
- (b) Certificate of Conformity.
- (c) Attributes record of measurements, tests and inspections performed in Chart II (including PDA figure) and Chart V (where applicable).
- (d) Failed components list.

10.1.2.2 *Unqualified Components*

For deliveries of unqualified components, the documentation to be supplied shall be in accordance with Para. 10.1.2.1 plus the following:

- (a) Special in-process control data (where applicable).
- (b) Failure analysis report on failed components.

10.1.3 Testing Level 'C'

Not applicable.

10.1.4 Data Retention/Data Access

If not delivered, all data shall be retained by the Manufacturer for a minimum of 5 years during which time it shall be available to the ESCC Executive and the Orderer, if requested, for review. The Manufacturer shall deliver variables Data/Reports to the Orderer if required by the Purchase Order.

10.2 COVER SHEET(S)

The cover sheet (or sheets) of the data documentation package shall include as a minimum:

- (a) Reference to the Detail Specification, including issue and date.
- (b) Reference to the applicable ESCC Generic Specification, including issue and date.
- (c) Component type and number.
- (d) Lot identification.
- (e) Number of purchase order.
- (f) Information relative to any additions to this specification and/or the Detail Specification.
- (g) Manufacturer's name and address.
- (h) Location of the manufacturing plant.
- (i) Signature on behalf of the Manufacturer.
- (j) Total number of pages of the data package.

10.3 LIST OF EQUIPMENT USED

A list of equipment used for tests and measurements shall be prepared if not in accordance with the data given in the PID. Where applicable, this list shall contain inventory number, Manufacturer's type number, serial number, etc. This list shall indicate for which tests such equipment was used.

10.4 LIST OF TEST REFERENCES

This list shall include all Manufacturer's references or codes which are necessary to correlate the test data provided with the applicable tests specified in the tables of the Detail Specification.

10.5 SPECIAL IN-PROCESS CONTROL DATA

The minimum and maximum values from the plating thickness measurements shall be provided.

10.6 FINAL PRODUCTION TEST DATA (CHART II)

A test result summary shall be compiled showing the total number of components submitted, and the total number rejected, after each of the following tests:

- Contact capability (Para. 9.4) (when applicable).
- Dimension check (contacts) (Para. 9.6) (when applicable).
- Installation of contacts into insert (Para. 9.8) (when applicable).
- Electrical measurements at room temperature (Para. 9.1.4) (when applicable)
- Mating verification (Para. 9.2) (when applicable).
- Seal Test (Para. 9.9) (when applicable).
- Contact retainer test (Para. 9.3) (when applicable).
- Magnetism level (Para. 9.5) (when applicable).
- Dimension check (connectors) (Para. 9.6).
- External visual inspection (Para. 9.7).

The final production test data shall form an integral part of the data documentation package, but it is not a mandatory requirement that it be delivered with the qualification lot or delivery lot. However, the data package to be delivered shall contain the information as detailed in Para. 10.1.2 or at least shall contain a list of final production tests actually performed and a certification that the data is available for review.

10.7 BURN-IN AND ELECTRICAL MEASUREMENT DATA (CHART III)

Not applicable.

10.8 QUALIFICATION TEST DATA (CHART IV)

All data shall be referenced to the relevant serial numbers. Detailed records shall be provided of the components submitted to each test in each of the subgroups and of those rejected.

Detailed data shall be provided of all electrical measurements made in accordance with Tables 2 and 6 of the Detail Specification, as and where applicable.

10.9 LOT ACCEPTANCE TEST DATA (CHART V)

10.9.1 Testing Level 'B'

All data shall be referenced to the relevant serial numbers. Detailed records shall be provided of the components submitted to each test in each of the subgroups (as relevant to the lot acceptance level) and of those rejected. Detailed data shall be provided of all electrical measurements made in accordance with Table 6 of the Detail Specification, as and where applicable.

10.9.2 Testing Level 'C'

Not applicable.

10.10 FAILED COMPONENTS LIST AND FAILURE ANALYSIS REPORT

The failed component list and failure analysis report shall provide full details of:

- (a) The reference number and description of the test or measurement performed as defined in this specification or the Detail Specification.
- (b) The serial number (if applicable) of the failed component.
- (c) The failed parameter and the failure mode of the component.
- (d) A detailed failure analysis, if requested.

10.11 CERTIFICATE OF CONFORMITY

A Certificate of Conformity shall be established as defined in ESCC Basic Specification No. 20100.

11 DELIVERY

For qualification approval, the disposition of the qualification test lot and its related documentation shall be as specified in ESCC Basic Specification No. 20100 and the relevant paragraphs of Section 10 of this specification. For procurement, for each order, the items forming the delivery are:

- (a) The delivery lot.
- (b) The components used for lot acceptance testing, (when applicable), but not forming part of the delivery lot (see Para's. 8.2.4(b) and 8.2.5(b)).
- (c) The relevant documentation in accordance with the requirements of Section 10 of this specification.

In the case of a component for which a valid qualification approval is in force, all data of all components submitted to LA1 and LA2 testing shall also be copied, when requested, to the ESCC Executive.

12 PACKAGING AND DESPATCH

The packaging and despatch of components to this specification shall be in accordance with the requirements of ESCC Basic Specification No. 20600.