



**ACCESSORIES FOR RECTANGULAR
CONNECTORS 3401/001, 3401/002 AND
CONNECTOR SAVERS 3401/020, 3401/080**

ESCC Detail Specification No. 3401/022

Issue 9	November 2014
---------	---------------



Document Custodian: European Space Agency – see <https://escies.org>

LEGAL DISCLAIMER AND COPYRIGHT

European Space Agency, Copyright © 2014. All rights reserved.

The European Space Agency disclaims any liability or responsibility, to any person or entity, with respect to any loss or damage caused, or alleged to be caused, directly or indirectly by the use and application of this ESCC publication.

This publication, without the prior permission of the European Space Agency and provided that it is not used for a commercial purpose, may be:

- copied in whole, in any medium, without alteration or modification.
- copied in part, in any medium, provided that the ESCC document identification, comprising the ESCC symbol, document number and document issue, is removed.

DOCUMENTATION CHANGE NOTICE

(Refer to <https://escies.org> for ESCC DCR content)

DCR No.	CHANGE DESCRIPTION
883	Specification upissued to incorporate changes per DCR.

TABLE OF CONTENTS

1	GENERAL	5
1.1	SCOPE	5
1.2	COMPONENT TYPE VARIANTS	5
1.3	MAXIMUM RATINGS	5
1.4	PARAMETER DERATING INFORMATION	5
1.5	PHYSICAL DIMENSIONS	5
2	APPLICABLE DOCUMENTS	5
3	TERMS, DEFINITIONS, ABBREVIATIONS, SYMBOLS AND UNITS	5
4	REQUIREMENTS	16
4.1	GENERAL	16
4.2	DEVIATIONS FROM GENERIC SPECIFICATION	16
4.2.1	Deviations from Special In-Process Controls	16
4.2.2	Deviations from Final Production Tests (Chart II)	17
4.2.3	Deviations from Burn-in and Electrical Measurements (Chart III)	17
4.2.4	Deviations from Qualification Tests (Chart IV)	17
4.2.5	Deviations from Lot Acceptance Tests (Chart V)	17
4.3	MECHANICAL REQUIREMENTS	17
4.3.1	Dimension Check	17
4.3.2	Weight	17
4.3.3	Torque Value	17
4.4	MATERIALS AND FINISHES	17
4.4.1	Screw Lock Assemblies, Potting Shells, Back Shells, Clamps	17
4.4.2	Dust Caps	17
4.4.3	Magnetism Level	17
4.5	MARKING	18
4.5.1	General	18
4.5.2	The ESCC Component Number	18
4.5.3	Characteristics	18
4.5.3.1	Magnetism Level (For Variants 01 to 06, 17 to 47, 58, 60 to 72, 81 to 83 and 86 to 96)	18
4.5.4	Traceability Information	18
4.6	ELECTRICAL MEASUREMENTS (TABLES 2 AND 3)	18
4.7	BURN-IN AND ELECTRICAL MEASUREMENTS (TABLES 4 AND 5)	18
4.8	ENVIRONMENTAL AND ENDURANCE TESTS (TABLE 6)	18

1 GENERAL

1.1 SCOPE

This specification details the ratings, physical and electrical characteristics, test and inspection data for Accessories for Rectangular Connectors (D*M and D*MA) and Connector Savers (D*BM and D*BMA). It shall be read in conjunction with ESCC Generic Specification No. 3401, the requirements of which are supplemented herein and ESCC Detail Specifications Nos. 3401/001, 3401/002, 3401/020 and 3401/080.

1.2 COMPONENT TYPE VARIANTS

The type variants of accessories covered by this specification are given in Table 1(a).

1.3 MAXIMUM RATINGS

The maximum ratings, which shall not be exceeded at any time during use or storage, applicable to the accessories specified herein, are given in Table 1(b).

1.4 PARAMETER DERATING INFORMATION

Not applicable.

1.5 PHYSICAL DIMENSIONS

The physical dimensions of the accessories specified herein are shown in Figure 2.

2 APPLICABLE DOCUMENTS

The following documents form part of this specification and shall be read in conjunction with it:

- (a) ESCC Generic Specification No. 3401, Connectors, Electrical, Non-Filtered, Circular and Rectangular.
- (b) ESCC Detail Specification No. 3401/001, Connectors, Electrical, Rectangular, Miniature, Non-removable Solder Bucket, PCB and Wire-Wrap Contacts and Removable Coaxial and Power Contacts, based on Type D*M.
- (c) ESCC Detail Specification No. 3401/002, Connectors, Electrical, Rectangular, Removable Crimp Contacts, based on type D*MA.
- (d) ESCC Detail Specification No. 3401/020, Connector Savers, Electrical, Rectangular, Miniature, Removable Contacts, based on type D*BMA.
- (e) ESCC Detail Specification No. 3401/080, Connector Savers, Electrical, Rectangular, Miniature, Non-removable Signal Contacts and Removable Coaxial and Power Contacts, based on type D*BM.

3 TERMS, DEFINITIONS, ABBREVIATIONS, SYMBOLS AND UNITS

For the purpose of this specification, the terms, definitions, abbreviations, symbols and units specified in ESCC Basic Specification No. 21300 shall apply.

TABLE 1(a) - TYPE VARIANTS

Variant	Description		Weight (g)
01	Screw Lock Assembly Brass (Female) (4-40)	-	1.9
02	Screw Lock Assembly Brass (Male/slotted head screw)	Without Back Shell	0.85
03	Screw Lock Assembly Brass (Male/slotted head screw)	Without Back Shell	0.85
04	Screw Lock Assembly Brass (Male/slotted head screw)	Without Back Shell	1
05	Screw Lock Assembly Brass (Male/slotted head screw)	Without Back Shell	1
06	Screw Lock Assembly Brass (Female) for Savers (4-40)	-	2
07	Dust Cap (Female)	Size E	N/A
08	Dust Cap (Male)	Size E	N/A
09	Dust Cap (Female)	Size A	N/A
10	Dust Cap (Male)	Size A	N/A
11	Dust Cap (Female)	Size B	N/A
12	Dust Cap (Male)	Size B	N/A
13	Dust Cap (Female)	Size C	N/A
14	Dust Cap (Male)	Size C	N/A
15	Dust Cap (Female)	Size D	N/A
16	Dust Cap (Male)	Size D	N/A
17	Potting Shell	Size A	N/A
18	Potting Shell	Size B	N/A
19	Potting Shell	Size C	N/A
20	Potting Shell	Size D	N/A
21	Back-Shell for Strapped Connections	Size A	8.6
22	Back-Shell for Strapped Connections	Size B	11.6
23	Back-Shell for Strapped Connections	Size C	15.5
24	Back-Shell for Strapped Connections	Size D	17.1
25	Cable Clamp, Straight	Size A	11.7
26	Cable Clamp, Straight	Size B	14.7
27	Cable Clamp, Straight	Size C	20
28	Cable Clamp, Straight	Size D	21.2
29	Cable Clamp, Round	Size E	9.7
30	Cable Clamp, Round	Size A	11
31	Cable Clamp, Round	Size B	13.3
32	Cable Clamp, Round	Size C	15.6
33	Cable Clamp, Round	Size D	16.5
34	Deep Straight Clamp	Size E	13.6
35	Deep Straight Clamp	Size A	17.2
36	Deep Straight Clamp	Size B	27.1
37	Deep Straight Clamp	Size C	39
38	Deep Straight Clamp	Size D	40.8
39	Right Angle Clamp	Size E	14.6

Variant	Description	Weight (g)
40	Right Angle Clamp Size A	17.2
41	Right Angle Clamp Size B	24.2
42	Right Angle Clamp Size C	33.5
43	Right Angle Clamp Size D	38.8
44	Screw Lock Assembly Brass (Male/slotted head screw) With Back Shell	0.85
45	Screw Lock Assembly Brass (Male/slotted head screw) With Back Shell	0.85
46	Screw Lock Assembly Brass (Male/slotted head screw) With Back Shell	1
47	Screw Lock Assembly Brass (Male/slotted head screw) With Back Shell	1
48	Screw Lock Assembly Stainless Steel (Female) (4-40) -	1.8
49	Screw Lock Assembly Stainless Steel (Male/slotted head screw) Without Back Shell	0.8
50	Screw Lock Assembly Stainless Steel (Male/slotted head screw) Without Back Shell	0.8
51	Screw Lock Assembly Stainless Steel (Male/slotted head screw) Without Back Shell	1
52	Screw Lock Assembly Stainless Steel (Male/slotted head screw) Without Back Shell	1
53	Screw Lock Assembly Stainless Steel (Female) for Savers (4-40)	1.9
54	Screw Lock Assembly Stainless Steel (Male/slotted head screw) With Back Shell	0.8
55	Screw Lock Assembly Stainless Steel (Male/slotted head screw) With Back Shell	0.8
56	Screw Lock Assembly Stainless Steel (Male/slotted head screw) With Back Shell	1
57	Screw Lock Assembly Stainless Steel (Male/slotted head screw) With Back Shell	1
58	Screw Lock Assembly Brass (Female) for Feedthrough (4-40) -	2
59	Screw Lock Assembly Stainless Steel (Female) for Feedthrough (4-40) -	1.86
60	60° Angled Clamp Size E	9
61	60° Angled Clamp Size A	11
62	60° Angled Clamp Size B	12
63	60° Angled Clamp Size C	15
64	60° Angled Clamp Size D	16
65	Screw Lock Assembly Brass (male/hex. hole head screw) Without Back Shell	0.85
66	Screw Lock Assembly Brass (male/hex. hole head screw) Without Back Shell	0.85
67	Screw Lock Assembly Brass (male/hex. hole head screw) Without Back Shell	1
68	Screw Lock Assembly Brass (male/hex. hole head screw) Without Back Shell	1
69	Screw Lock Assembly Brass (male/hex. hole head screw) With Back Shell	0.85
70	Screw Lock Assembly Brass (male/hex. hole head screw) With Back Shell	0.85
71	Screw Lock Assembly Brass (male/hex. hole head screw) With Back Shell	1
72	Screw Lock Assembly Brass (male/hex. hole head screw) With Back Shell	1
73	Screw Lock Assembly Stainless Steel (Male/hex. hole head screw) Without Back Shell	0.8
74	Screw Lock Assembly Stainless Steel (Male/hex. hole head screw) Without Back Shell	0.8
75	Screw Lock Assembly Stainless Steel (Male/hex. hole head screw) Without Back Shell	1
76	Screw Lock Assembly Stainless Steel (Male/hex. hole head screw) Without Back Shell	1

Variant	Description		Weight (g)
77	Screw Lock Assembly Stainless Steel (Male/hex. hole head screw)	With Back Shell	0.8
78	Screw Lock Assembly Stainless Steel (Male/hex. hole head screw)	With Back Shell	0.8
79	Screw Lock Assembly Stainless Steel (Male/hex. hole head screw)	With Back Shell	1
80	Screw Lock Assembly Stainless Steel (Male/hex. hole head screw)	With Back Shell	1
81	Potting shell	Size E	N/A
82	Back-Shell for Strapped Connections	Size E	6.7
83	Cable Clamp, Straight	Size E	9
84	Dust Cap (Female)	Size F	N/A
85	Dust Cap (Male)	Size F	N/A
86	Screw Lock Assembly Brass (Male/slotted head screw)	Without Back Shell	0.8
87	Screw Lock Assembly Brass (Male/slotted head screw)	With Back Shell	1
88	Screw Lock Assembly Brass (Male/hex. hole head screw)	Without Back Shell	0.8
89	Screw Lock Assembly Brass (Male/hex. hole head screw)	With Back Shell	1
90	Potting shell	Size F	N/A
91	Back-Shell for Strapped Connections	Size F	36
92	Cable Clamp, Straight	Size F	42
93	Cable Clamp, Round	Size F	21
94	Deep Straight Clamp	Size F	58
95	Right Angle Clamp	Size F	48
96	Screw Lock Assembly Brass (Female) (Hybrid 4-40/M3)	-	1.9

TABLE 1(b) - MAXIMUM RATINGS

No.	Characteristic	Symbol	Maximum Ratings		Unit	Remarks
1	Operating Temperature Range	T_{op}	-55 to +125 (1)		°C	T_{amb}
2	Storage Temperature Range	T_{stg}	-55 to +125 (1)		°C	
3	Torque Value for Screws	T_{qe}	BRASS 5.5 3.3	S.S. 6.6 4.4	cm.daN cm.daN	For Female (2) For Male

NOTES:

1. Except for dust cap: +100°C.
2. Except for Variants 6, 53, 58 and 59 which shall be tightened to the torque specified for the Male.

FIGURE 1 - PARAMETER DERATING INFORMATION

Not applicable.

FIGURE 2 - PHYSICAL DIMENSIONS

FIGURE 2(a) - SCREW LOCK ASSEMBLIES (all dimensions in millimetres)

MATED SPACING BETWEEN SHELL FRONT SURFACES

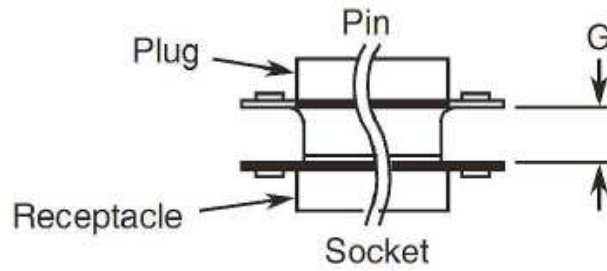

Screw Lock Assembly (Female) (4-40) (Note 1)

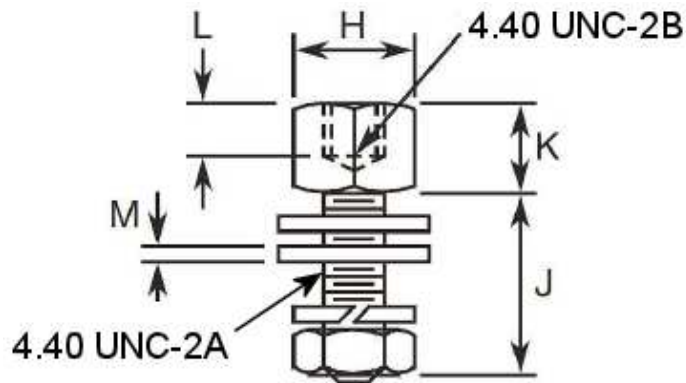

Dimension	Min.	Max.	Notes
G	6.35	7.11	1
	6.12	6.88	2
H	4.37	5.13	-
J	7.54	8.3	3
	14.35	14.65	4
	15.49	16.25	5
K	4.6	5.1	-
L	3.18	-	-
M	0.66	0.86	6

Screw Lock Assembly (Female) (Hybrid 4-40/M3) (Note 2)

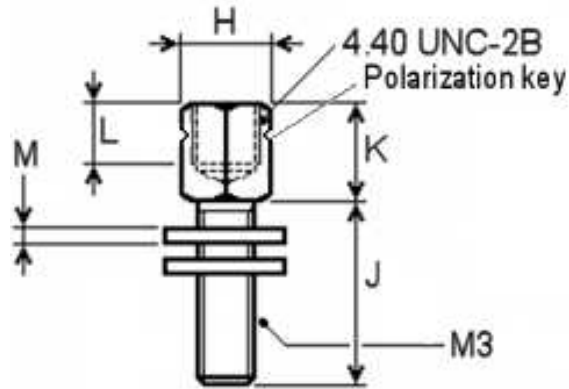

Dimension	Min.	Max.	Notes
G	6.35	7.11	1
	6.12	6.88	2
H	4.52	4.62	-
J	7.8	8.04	3
K	4.8	4.9	-
L	3.18	-	-
M	0.78	0.82	6

NOTES:

1. Variants 01, 06, 48, 53, 58 & 59; to be used with A7N, B7N, C7N & D7N connectors.
2. Variant 96; to be used with A9N, B9N, C9N & D9N and L9 3401/001 connectors
3. For shell sizes E and A.
4. For shell sizes B, C and D.
5. Variants 01, 48 and 96 (standard). To be used with all sizes of shells, P or S, with or without backshell.
6. Variants 06 and 53 (for savers). To be used with all sizes of shells.
7. Variants 58 and 59 (for feedthrough). To be used with all sizes of shells.
8. The spacing between the reference planes of 2 mated connectors shall be adjusted by the use of 3 washers maximum so the spacing is equal to dimension G.

SCREW LOCK ASSEMBLY (MALE)

Configuration 1

Configuration 2 (with Slotted Head shown for illustrative purposes)

Hex. Hole Head
(see below)

Slotted Head
(see below)

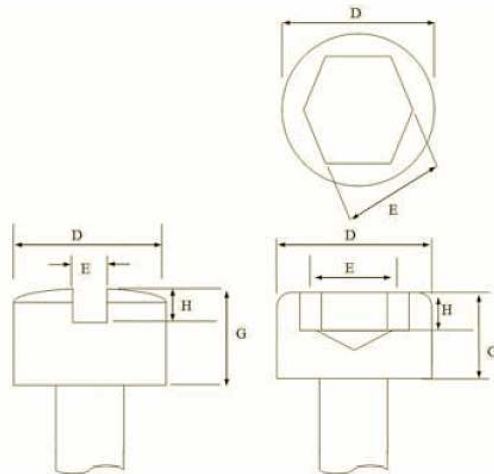
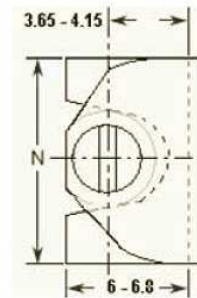
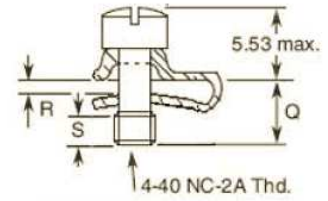
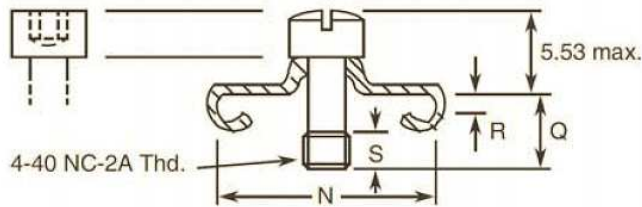

	D		E (Note 1)		G		H	
	MIN	MAX	MIN	MAX	MIN	MAX	MIN	MAX
Slotted Head	3.9	4.65	0.75	1.1	1.9	2.71	0.75	1.1
Hex. Hole Head	4.32	4.6	2.02	2.08	2.36	2.9	1	1.4

NOTES

1. Measured across flats (Hex. Hole Head only).

	VARIANT				USE WITH SHELL SIZE	N		Q		R		S
	BRASS		S.S.			MIN.	MAX.	MIN.	MAX.	MIN.	MAX.	MIN.
CONFIGURATION 1	Slot.	Hex.	Slot.	Hex.	Without Back Shell							
	02	65	49	73	DA DE: (P or S) DB, DC: S	12.96	13.72	3.22	3.98	0.75	0.95	2.8
	03	66	50	74	DB DC: P	12.96	13.72	3.22	3.98	0.95	1.15	2.8
	04	67	51	75	DD: S	15.75	16.26	4.02	4.78	0.75	0.95	2.8
	05	68	52	76	DD: P	15.75	16.26	4.02	4.78	0.95	1.15	2.8
	Slot.	Hex.	Slot.	Hex.	With Back Shell							
	44	69	54	77	DA DE: (P or S) DB, DC: S	12.96	13.72	4.02	4.78	1.75	1.95	2.8
	45	70	55	78	DB DC: P	12.96	13.72	4.02	4.78	2	2.2	2.8
CONFIG. 2	46	71	56	79	DD: S	15.75	16.26	4.02	4.78	1.75	1.95	2.8
	47	72	57	80	DD: P	15.75	16.26	4.02	4.78	2	2.2	2.8
	Slot.	Hex.	Slot.	Hex.								
	86	88	-	-	All Sizes Without Back Shell	12.17	12.93	3.22	3.98	0.7	0.9	2.8
	87	89	-	-	All Sizes With Back Shell	12.17	12.93	4.02	4.78	1.3	1.5	2.8

FIGURE 2(b) - DUST CAPS (all dimensions in millimetres)

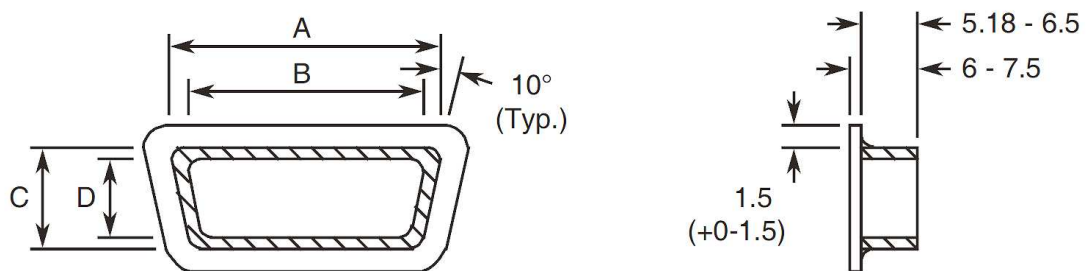

Variant	A		B		C		D	
	Min.	Max.	Min.	Max.	Min.	Max.	Min.	Max.
07	17.3	17.9	15.6	16.2	8.9	9.5	7.2	7.8
08	18.7	19.3	17	17.6	10.2	10.8	8.5	9.1
09	25.7	26.3	24	24.6	8.9	9.5	7.2	7.8
10	27.1	27.7	25.4	26	10.2	10.8	8.5	9.1
11	39.4	40	37.7	38.3	8.9	9.5	7.2	7.8
12	41.2	41.8	39.5	40.1	10.2	10.8	8.9	9.6
13	55.8	56.4	54.1	54.7	8.9	9.5	7.2	7.8
14	57.6	58.2	56	56	10.2	10.8	8.9	9.6
15	53.4	54	51.7	52.3	11.7	12.3	10	10.6
16	55	55.6	53.3	53.9	13.3	13.9	11.6	12.2
84	57	57.6	55.3	55.9	13.4	14	11.7	12.3
85	58.9	59.5	57.2	57.8	15.4	16	13.7	14.3

FIGURE 2(c) - POTTING SHELLS (all dimensions in millimetres)

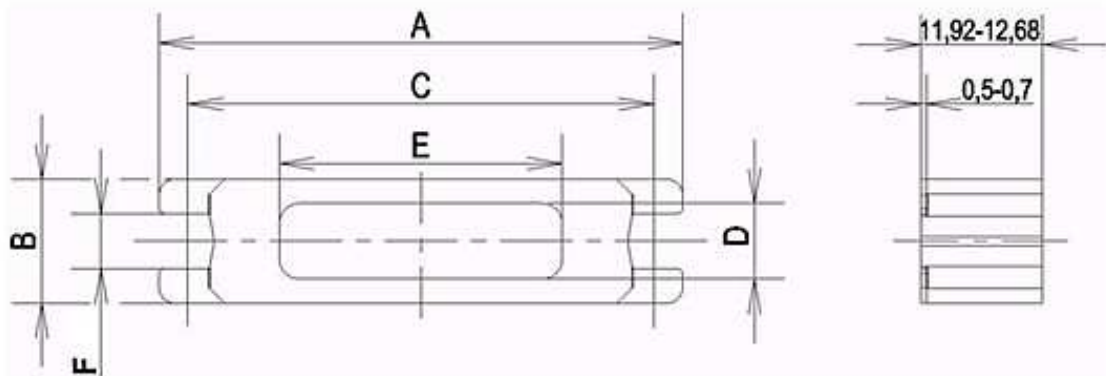

NOTES:

1. Weight: Not applicable because not on board.

Variant	A		B		C		D		E		F	
	Min.	Max.	Min.	Max.	Min.	Max.	Min.	Max.	Min.	Max.	Min.	Max.
81	30.32	31.08	12.32	13.08	24.74	25.24	7.1	8.1	8.48	9.52	5.5	5.7
17	38.51	39.27	12.32	13.08	33.08	33.58	7.1	8.1	14.4	15.44	5.5	5.7
18	52.4	53.16	12.32	13.08	46.79	47.29	7.1	8.1	28	29.08	5.5	5.7
19	68.66	69.42	12.32	13.08	63.25	63.75	7.1	8.1	43.94	45	5.5	5.7
20	66.29	67.05	15.09	15.85	60.86	61.36	9.4	10.4	43.94	45	5.5	5.7
90	68.84	69.6	17.09	17.85	63.15	63.65	10.5	11.5	43.47	44.53	2.92	3.18

FIGURE 2(d) - BACK SHELLS (FOR STRAPPED CONNECTIONS) (all dimensions in millimetres)

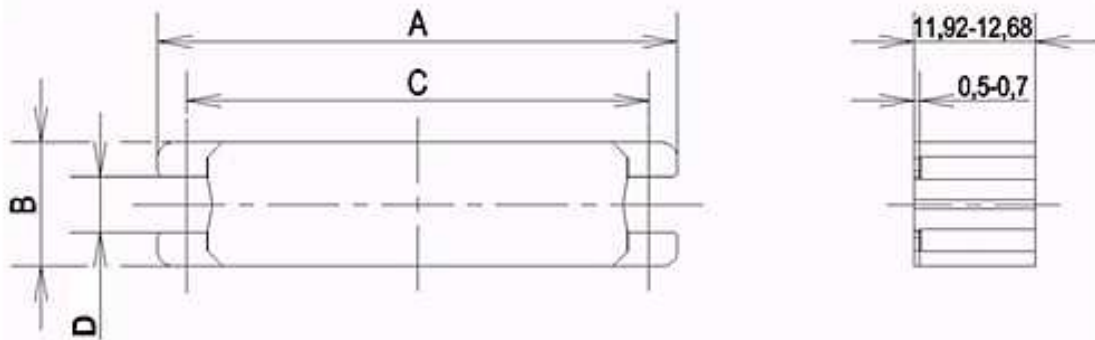

Variant	A		B		C		D	
	Min.	Max.	Min.	Max.	Min.	Max.	Min.	Max.
82	30.32	31.08	12.32	13.08	24.74	25.24	5.5	5.7
21	38.51	39.27	12.32	13.08	33.08	33.58	5.5	5.7
22	52.4	53.16	12.32	13.08	46.79	47.29	5.5	5.7
23	68.66	69.42	12.32	13.08	63.25	63.75	5.5	5.7
24	66.29	67.05	15.09	15.85	60.86	61.36	5.5	5.7
91	68.84	69.6	17.09	17.85	63.15	63.55	2.92	3.18

FIGURE 2(e) - CABLE CLAMPS (all dimensions in millimetres)

STRAIGHT CLAMP

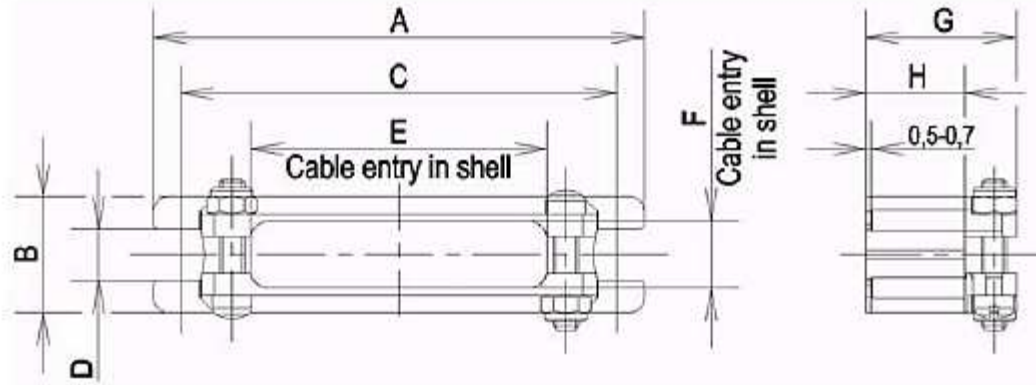

Variant	No. of Cable Locking Screws Required	A		B		C		D		E		F		G		H	
		Min.	Max.	Min.	Max.	Min.	Max.	Min.	Max.	Min.	Max.	Min.	Max.	Min.	Max.	Min.	Max.
83	2	30.32	31.08	12.32	13.08	24.74	25.24	5.5	5.7	10.62	11.38	7.12	7.88	15.7	16.7	10.32	11.08
25	2	38.51	39.27	12.32	13.08	33.08	33.58	5.5	5.7	18.62	19.38	7.12	7.88	15.7	16.7	10.32	11.08
26	2	52.4	53.16	12.32	13.08	46.79	47.29	5.5	5.7	31.62	32.38	7.12	7.88	15.7	16.7	10.32	11.08
27	3	68.66	69.42	12.32	13.08	63.25	63.75	5.5	5.7	47.62	48.38	7.12	7.88	15.7	16.7	10.32	11.08
28	3	66.29	67.05	15.09	15.85	60.86	61.36	5.5	5.7	45.62	46.38	9.52	10.28	17.3	18.3	11.92	12.68
92	3	68.84	69.6	17.09	18.85	63.15	63.65	2.92	3.18	43.47	44.53	10.5	11.5	32.1	33.1	24.62	25.38

ROUND CLAMP

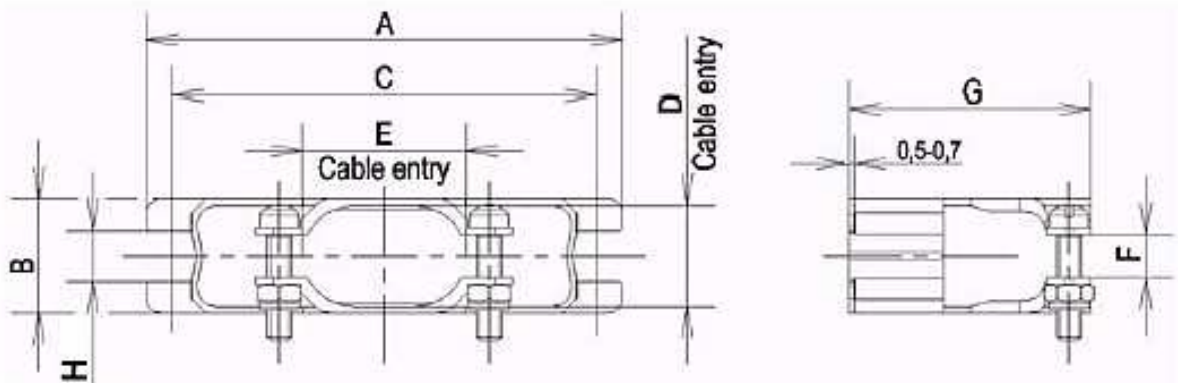

Variant	A		B		C		D		E		F		G		H	
	Min.	Max.	Min.	Max.	Min.	Max.	Min.	Max.	Min.	Max.	Min.	Max.	Min.	Max.	Min.	Max.
29	30.32	31.08	12.32	13.08	24.74	25.24	10.12	10.88	10.12	10.88	2.82	3.58	25.4	27	5.5	5.7
30	38.51	39.27	12.32	13.08	33.08	33.58	10.72	11.48	10.72	11.48	2.82	3.58	25.4	27	5.5	5.7
31	52.4	53.16	12.32	13.08	46.79	47.29	10.72	11.48	17.72	18.48	4.32	5.08	26.2	27.8	5.5	5.7
32	68.66	69.42	12.32	13.08	63.25	63.75	10.72	11.48	24.72	25.48	5.92	6.73	26.2	27.8	5.5	5.7
33	66.29	67.05	15.09	15.85	60.86	61.36	13.62	14.28	26.52	27.28	7.52	8.28	26.2	27.8	5.5	5.7
93	68.84	69.6	17.09	17.85	63.15	63.65	15.62	16.28	22.92	23.68	7.52	8.28	31.2	32.8	2.92	3.18

DEEP STRAIGHT CLAMP

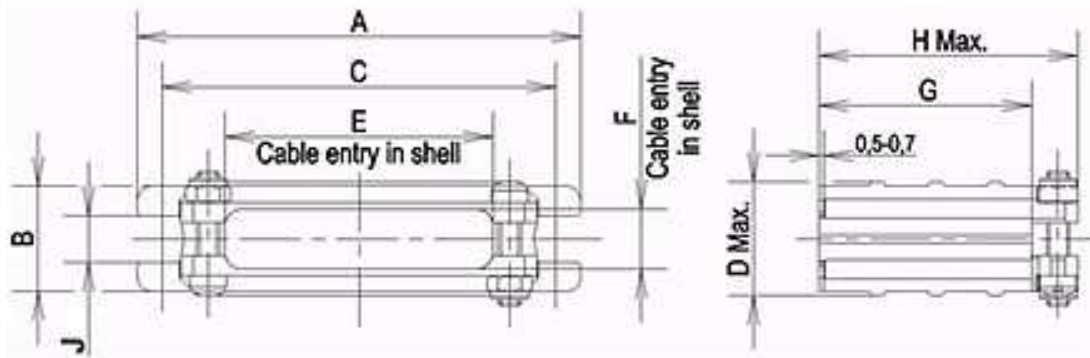

Variant	A		B		C		D	E		F		G		H	J	
	Min.	Max.	Min.	Max.	Min.	Max.		Min.	Max.	Min.	Max.	Min.	Max.		Min.	Max.
34	30.32	31.08	12.32	13.08	24.74	25.24	14.7	10.62	11.38	7.12	7.88	18.62	19.38	31.7	5.5	5.7
35	38.51	39.27	12.32	13.08	33.08	33.58	14.7	18.62	19.38	7.12	7.88	18.62	19.38	31.7	5.5	5.7
36	52.4	53.16	12.32	13.08	46.79	47.29	14.7	31.62	32.38	7.12	7.88	25.02	25.78	39.7	5.5	5.7
37	68.66	69.42	12.32	13.08	63.25	63.75	14.7	47.62	48.38	7.12	7.88	25.02	25.78	39.7	5.5	5.7
38	66.29	67.05	15.09	15.85	60.86	61.36	17.4	45.62	46.38	9.52	10.28	28.22	28.98	42.9	5.5	5.7
94	68.84	69.6	17.09	17.85	63.15	63.65	19.4	43.47	44.53	10.5	11.5	36.42	37.18	53.2	2.92	3.18

RIGHT ANGLE CLAMP

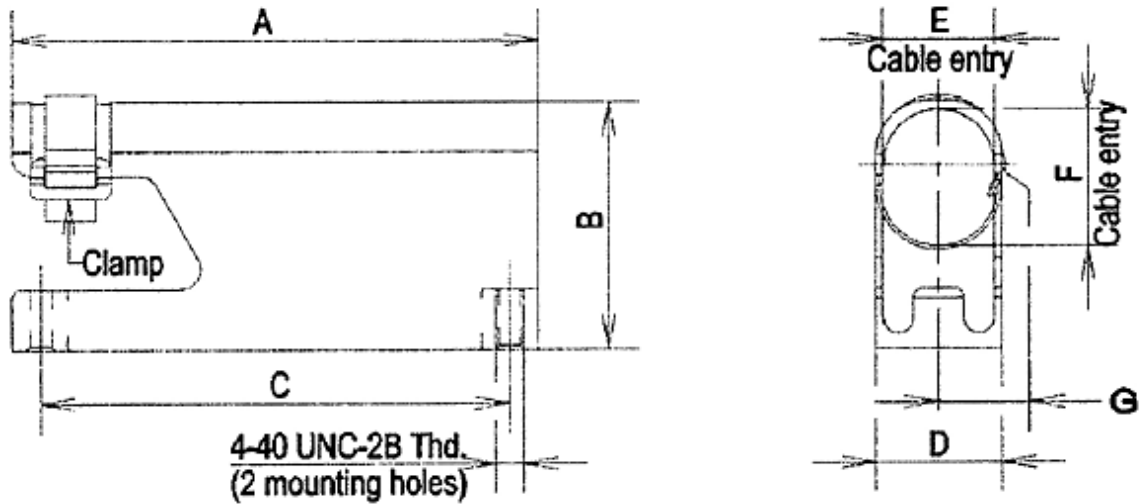

Variant	A		B		C		D		E		F		G
	Min.	Max.	Min.	Max.	Min.	Max.	Min.	Max.	Min.	Max.	Min.	Max.	Max.
39	30.32	31.08	17.4	19	24.74	25.24	12.32	13.08	10.3	11.9	10.3	11.9	7.9
40	38.51	39.27	17.4	19	33.08	33.58	12.32	13.08	10.3	11.9	10.3	11.9	7.9
41	52.4	53.16	23.8	25.4	46.79	47.29	12.32	13.08	10.3	11.9	15.1	16.7	7.9
42	68.66	69.42	29.3	30.9	63.25	63.75	12.32	13.08	10.3	11.9	19.8	21.4	7.9
43	66.29	67.05	30.9	32.5	60.86	61.36	15.09	15.85	13.5	15.1	22.3	23.9	7.9
95	68.84	69.6	32.2	33.8	63.15	63.65	17.09	17.85	15.5	17.1	24.3	25.9	10

60° ANGLED CLAMP

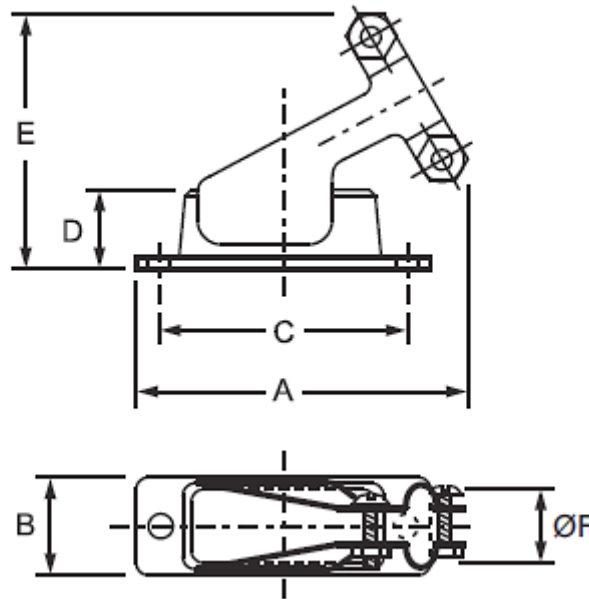

Variant	A		B		C		D		E		ØF	
	Min.	Max.	Min.	Max.	Min.	Max.	Min.	Max.	Min.	Max.	Min.	Max.
60	38.75	39.25	12.45	12.95	24.74	25.24	12.05	12.55	30.35	30.85	9.75	10.25
61	42.85	43.35	12.45	12.95	32.07	32.57	12.05	12.55	32.25	32.75	9.75	10.25
62	55.15	55.65	12.45	12.95	46.79	47.29	12.05	12.55	34.25	34.75	14.75	15.25
63	75.05	75.55	12.45	12.95	63.25	63.75	12.05	12.55	37.25	37.75	17.75	18.25
64	72.55	73.05	15.15	15.65	60.86	61.36	12.05	12.55	37.35	37.85	19.75	20.25

4 REQUIREMENTS

4.1 GENERAL

The complete requirements for procurement of the accessories specified herein are stated in this specification and ESCC Generic Specification No. 3401. Deviations from the Generic Specification, applicable to this specification only, are listed in Para. 4.2.

Deviations from the applicable Generic Specification and this Detail Specification, formally agreed with specific Manufacturers on the basis that the alternative requirements are equivalent to the ESCC requirements and do not affect the components' reliability, are listed in the appendices attached to this specification.

4.2 DEVIATIONS FROM GENERIC SPECIFICATION

4.2.1 Deviations from Special In-Process Controls

- (a) Para. 5.2.2, Gold Plating Porosity: Not applicable.
- (b) Para. 5.2.3, Plating Thickness: Not applicable.

4.2.2 Deviations from Final Production Tests (Chart II)

Only the following tests shall be performed:

- (a) Para. 4.4, Marking.
- (b) Para. 9.6, Dimension Check.
- (c) Para. 9.7, External Visual Inspection. The magnification shall be X3.

4.2.3 Deviations from Burn-in and Electrical Measurements (Chart III)

Chart III is not applicable.

4.2.4 Deviations from Qualification Tests (Chart IV)

Not applicable.

4.2.5 Deviations from Lot Acceptance Tests (Chart V)

Not applicable.

4.3 MECHANICAL REQUIREMENTS

4.3.1 Dimension Check

The dimensions of the accessories specified herein shall be verified in accordance with the requirements set out in Para. 9.6 of ESCC Generic Specification No. 3401 and shall conform to those shown in Figure 2 of this specification.

4.3.2 Weight

The maximum weight of the accessories specified herein shall be as shown in Table 1(a) of this specification.

4.3.3 Torque Value

The torque value to be used for tightening the screws of the accessories specified herein shall be as mentioned in Table 1(b) of this specification.

4.4 MATERIALS AND FINISHES

The materials and finishes shall be as specified herein. Where a definite material is not specified, a material which will enable the components specified herein to meet the performance requirements of this specification shall be used. Acceptance or approval of any constituent material does not guarantee acceptance of the finished product.

4.4.1 Screw Lock Assemblies, Potting Shells, Back Shells, Clamps

Screw lock assemblies (brass), potting shells, back shells and clamps shall be made of brass with gold (0.7µm minimum) over copper (1µm minimum) plating.

Screw lock assemblies (stainless steel) shall be made of passivated stainless steel.

4.4.2 Dust Caps

Material: Red, black or white polyethelene.

4.4.3 Magnetism Level

The allowable value of magnetism shall not exceed that specified for the relevant level (see Para. 4.5.3.1).

4.5 MARKING

4.5.1 General

The marking of components delivered to this specification shall be in accordance with the requirements of ESCC Basic Specification No. 21700 and the following paragraphs. When the component is too small to accommodate all of the marking as specified, as much as space permits shall be marked and the marking information, in full, shall accompany the component in its primary package.

The information to be marked and the order of precedence, shall be as follows:

- (a) The ESCC Component Number.
- (b) Characteristics.
- (c) Traceability Information.

4.5.2 The ESCC Component Number

Each component shall bear the ESCC Component Number which shall be constituted and marked as follows:

Example: 340102201B

- Detail Specification Number: 3401022
- Type Variant (See Table 1(a)): 01
- Testing Level: B

4.5.3 Characteristics

The characteristics to be marked in the following order of precedence are:

- (a) Magnetism Level.

4.5.3.1 *Magnetism Level (For Variants 01 to 06, 17 to 47, 58, 60 to 72, 81 to 83 and 86 to 96)*

The following codes shall be used for magnetism level:

Code	Definition
NMA	Magnetism Level: \leq 2000 gamma
NMB	Magnetism Level: \leq 200 gamma
NMC	Magnetism Level: \leq 20 gamma
NMD	Magnetism Level: \leq 2 gamma

4.5.4 Traceability Information

Traceability information shall be marked in accordance with ESCC Basic Specification No. 21700.

4.6 ELECTRICAL MEASUREMENTS (TABLES 2 AND 3)

Not applicable.

4.7 BURN-IN AND ELECTRICAL MEASUREMENTS (TABLES 4 AND 5)

Not applicable.

4.8 ENVIRONMENTAL AND ENDURANCE TESTS (TABLE 6)

Not applicable.