



**FAST-LOCKING SCREW LOCK ASSEMBLIES FOR
RECTANGULAR CONNECTORS 3401/001, 3401/002
AND CONNECTOR SAVERS 3401/020, 3401/080**

ESCC Detail Specification No. 3401/085

Issue 3	September 2015
---------	----------------



LEGAL DISCLAIMER AND COPYRIGHT

European Space Agency, Copyright © 2015. All rights reserved.

The European Space Agency disclaims any liability or responsibility, to any person or entity, with respect to any loss or damage caused, or alleged to be caused, directly or indirectly by the use and application of this ESCC publication.

This publication, without the prior permission of the European Space Agency and provided that it is not used for a commercial purpose, may be:

- copied in whole, in any medium, without alteration or modification.
- copied in part, in any medium, provided that the ESCC document identification, comprising the ESCC symbol, document number and document issue, is removed.

DOCUMENTATION CHANGE NOTICE

(Refer to <https://escies.org> for ESCC DCR content)

DCR No.	CHANGE DESCRIPTION
915	Specification upissued to incorporate editorial and technical changes per DCR.

TABLE OF CONTENTS

1	GENERAL	6
1.1	SCOPE	6
1.2	COMPONENT TYPE VARIANTS AND RANGE OF COMPONENTS	6
1.3	MAXIMUM RATINGS	6
1.4	PARAMETER DERATING INFORMATION	6
1.5	PHYSICAL DIMENSIONS	6
2	APPLICABLE DOCUMENTS	6
3	TERMS, DEFINITIONS, ABBREVIATIONS, SYMBOLS AND UNITS	6
4	REQUIREMENTS	11
4.1	GENERAL	11
4.2	DEVIATIONS FROM GENERIC SPECIFICATION	11
4.2.1	Deviations from Special In-Process Controls	11
4.2.2	Deviations from Final Production Tests (Chart II)	11
4.2.3	Deviations from Burn-in and Electrical Measurements (Chart III)	11
4.2.4	Deviations from Qualification Tests (Chart IV)	12
4.2.5	Deviations from Lot Acceptance Tests (Chart V)	13
4.3	MECHANICAL REQUIREMENTS	14
4.3.1	Dimension Check	14
4.3.2	Weight	14
4.3.3	Maximum Torque Application	14
4.3.3.1	Coupling Nut Unlocking Torque	14
4.3.4	Locking/Unlocking Forces	14
4.3.5	Life Test Locking – Unlocking	15
4.3.6	Fast-Locking Screw Lock Retention on Shells	16
4.3.7	Clip Retention Inside Bushing	16
4.3.8	Pull Test on Mated Screw Lock Assemblies	17
4.3.9	Security Pin Retention in Male Fast-Locking Screw Lock Assemblies	18
4.3.10	Mechanical Sequence	18
4.3.11	Environmental Sequence	19
4.4	MATERIALS AND FINISHES	19
4.4.1	Fast-Locking Screw Lock Assemblies	19
4.4.2	Magnetism Level	19
4.5	MARKING	20
4.5.1	General	20
4.5.2	The ESCC Component Number	20
4.5.2.1	Characteristics	20
4.5.3	Traceability Information	20
4.6	ELECTRICAL MEASUREMENTS	20

4.7	BURN-IN AND ELECTRICAL MEASUREMENTS	20
4.8	ENVIRONMENTAL AND ENDURANCE TESTS	20
4.8.1	Measurements and Inspections on Completion of Environmental Tests	20
4.8.2	Measurements and Inspections at Intermediate Points During Endurance Tests	20
4.8.3	Measurements and Inspections on Completion of Endurance Tests	21
4.8.4	Conditions for Operating Life Test (Part of Endurance Testing)	21
4.8.5	Electrical Circuits for Operating Life Test	21
4.8.6	Conditions for High Temperature Storage Test (Part of Endurance Testing)	21

1 GENERAL

1.1 SCOPE

This specification details the ratings, physical and electrical characteristics, test and inspection data for Fast-Locking Screw Lock Assemblies for Rectangular Connectors (D*M and D*MA) and Connector Savers (D*BM and D*BMA). It shall be read in conjunction with ESCC Generic Specification No. 3401, the requirements of which are supplemented herein, and ESCC Detail Specifications Nos. 3401/001, 3401/002, 3401/020, 3401/022, 3401/072 and 3401/080.

1.2 COMPONENT TYPE VARIANTS AND RANGE OF COMPONENTS

The type variants of accessories covered by this specification are given in Table 1(a).

1.3 MAXIMUM RATINGS

The maximum ratings, which shall not be exceeded at any time during use or storage, applicable to the accessories specified herein, are given in Table 1(b).

1.4 PARAMETER DERATING INFORMATION

Not applicable.

1.5 PHYSICAL DIMENSIONS

The physical dimensions of the accessories specified herein are shown in Figure 2.

2 APPLICABLE DOCUMENTS

The following documents form part of this specification and shall be read in conjunction with it:

- (a) ESCC Generic Specification No. 3401, Connectors, Electrical, Non-Filtered, Circular and Rectangular.
- (b) ESCC Detail Specification No. 3401/001, Connectors, Electrical, Rectangular, Miniature, Non-removable Solder Bucket, PCB and Wire-Wrap Contacts and Removable Coaxial and Power Contacts, based on Type D*M.
- (c) ESCC Detail Specification No. 3401/002, Connectors, Electrical, Rectangular, Removable Crimp Contacts, based on Type D*MA.
- (d) ESCC Detail Specification No. 3401/020, Connector Savers, Electrical, Rectangular, Miniature, Removable Contacts, based on Type D*BMA.
- (e) ESCC Detail Specification No. 3401/022, Accessories for Rectangular Connectors 3401/001, 3401/002 and Connector Savers 3401/020, 3401/080.
- (f) ESCC Detail Specification No. 3401/072, Lightweight Accessories for Rectangular Connectors 3401/001 and 3401/002.
- (g) ESCC Detail Specification No. 3401/080, Connector Savers, Electrical, Rectangular, Miniature, Non-removable Signal Contacts and Removable Coaxial and Power Contacts, based on Type D*BM.
- (h) MIL-DTL-81969/39, Detail Specification Sheet, Installing And Removal Tool, Connector Electrical Contacts, Type III, Class 2, Composition B.

3 TERMS, DEFINITIONS, ABBREVIATIONS, SYMBOLS AND UNITS

For the purpose of this specification, the terms, definitions, abbreviations, symbols and units specified in ESCC Basic specification No. 21300 shall apply.

TABLE 1(a) – TYPE VARIANTS

Variant	Description	Weight Max (g)
01	Male Fast-Locking Screw Lock Assembly, For Connectors without Back Shell, Brass	1
02	Male Fast-Locking Screw Lock Assembly, For Connectors with Back Shell, Brass (1)	1
03	Female Fast-Locking Screw Lock Assembly, Brass	1.5
04	Fast-Locking Screw Lock Assembly, For Saver Connectors, Brass	1.2
05	Fast-Locking Screw Lock Assembly, For Hybrid Saver Connectors, Brass	1.2
06	Security Pin For Male Fast-Locking Screw Lock Assemblies	0.3

NOTES:

- Backshells compatibles with Male Fast-Locking Screw Lock Assembly (Variant 02) are listed below :
 - ESCC Detail Specification No. 3401/022: Variants 17 to 38, Variants 81 to 83 and Variants 90 to 94.
 - ESCC Detail Specification No. 3401/072: Variants 05 to 14, Variants 35 to 39, Variants 46 to 50 and Variants 61 to 65

TABLE 1(b) – MAXIMUM RATINGS

No.	Characteristic	Symbol	Maximum Ratings	Unit	Remarks
1	Operating Temperature Range	T_{op}	-55 to +125	°C	T_{amb}
2	Storage Temperature Range	T_{stg}	-55 to +125	°C	
3	Locking Force Variants 01, 02, 04:	F_{LO}	15	N	
4	Unlocking Force Variants 01, 02, 04:	F_{UN}	30	N	
5	Torque Value for Nuts and Bushing Variants 03, 05:	T_{qe}	See Figure 2	cm.daN	

FIGURE 1 – PARAMETER DERATING INFORMATION

Not applicable.

FIGURE 2 – PHYSICAL DIMENSIONS

MATED SPACING BETWEEN SHELL FRONT SURFACES

(All dimensions in millimetres)

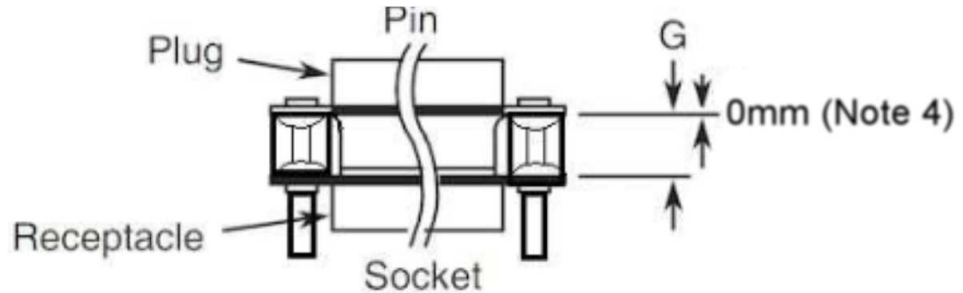

Dimension	Min	Max	Notes
G	6.35	7.11	1, 3
	6.12	6.88	2, 3

NOTES:

1. For shell sizes E and A.
2. For shell sizes B, C, D and F.
3. The spacing between the reference planes of two mated connectors shall be adjusted by the use of three washers maximum (see Variant 03 dimensions) so the spacing is equal to dimension G.
4. The locking operation shall not be performed before there is no gap between the Female Fast-Locking Screw Lock Assembly and shell front surface.

MALE FAST-LOCKING SCREW LOCK ASSEMBLIES (VARIANTS 01 AND 02)

(All dimensions in millimetres)

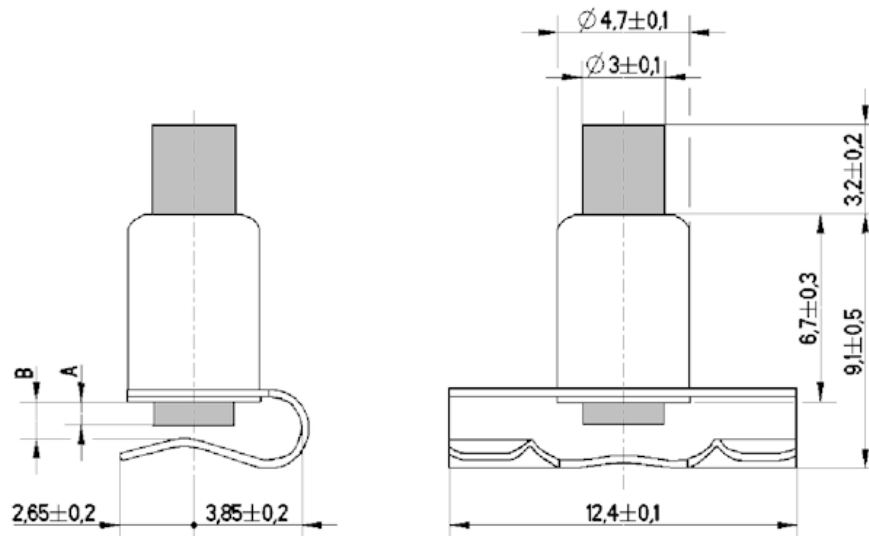

Variant	Dimension A		Dimension B	
	Min	Max	Min	Max
01	0.6	1	1.1	1.5
02	1	1.4	1.5	1.9

FIGURE 2 – PHYSICAL DIMENSIONS (CONTINUED)

FEMALE FAST-LOCKING SCREW LOCK ASSEMBLY (VARIANT 03)

(All dimensions in millimetres)

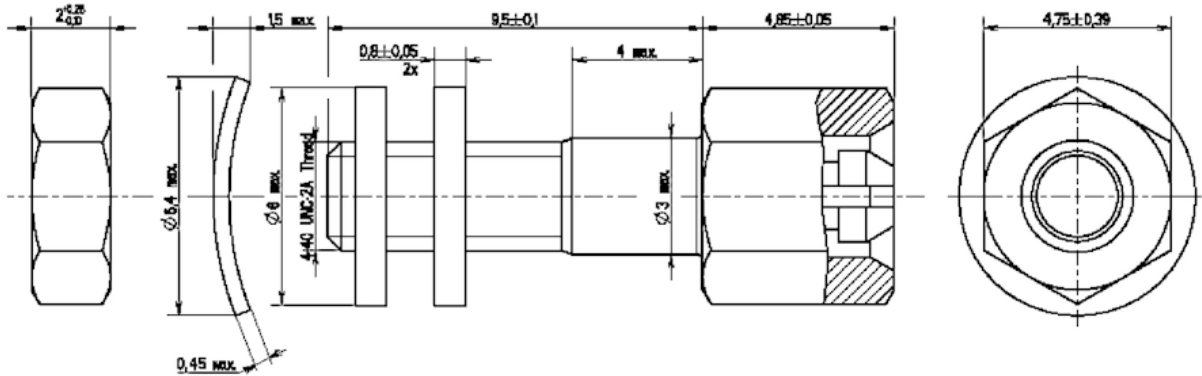

No.	Characteristics	Symbol	Min Limit	Max Limit	Unit
1	Torque Value for Nuts	Tqe	4.4	4.9	cm.daN

FAST-LOCKING SCREW LOCK ASSEMBLY FOR SAVER CONNECTORS (VARIANT 04)

(All dimensions in millimetres)

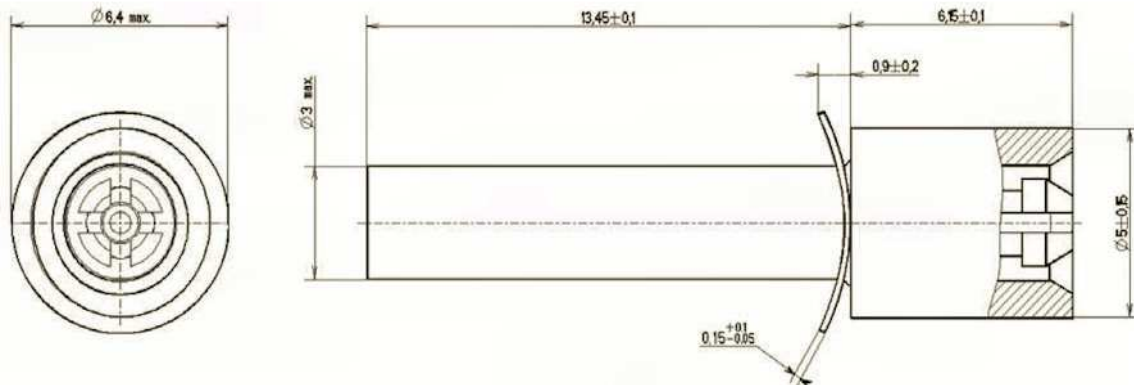

FAST-LOCKING SCREW LOCK ASSEMBLY FOR HYBRID SAVER CONNECTORS (VARIANT 05)

(All dimensions in millimetres)

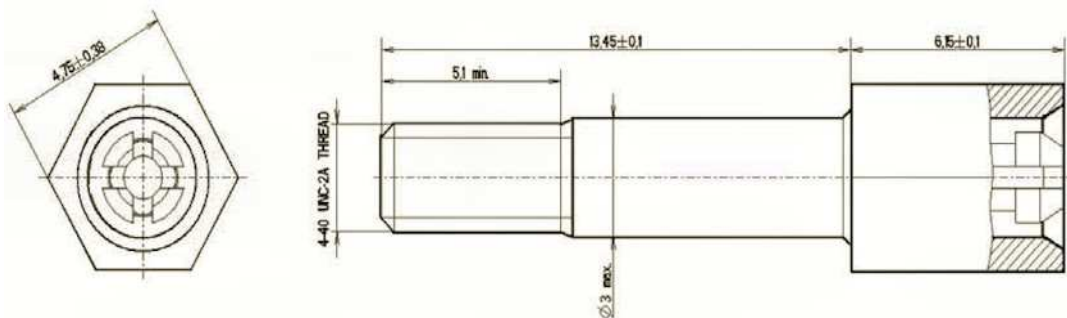

No.	Characteristics	Symbol	Min Limit	Max Limit	Unit
1	Torque Value for Bushing	Tqe	4.4	4.9	cm.daN

**SECURITY PIN FOR MALE FAST-LOCKING SCREW LOCK ASSEMBLIES
(VARIANT 06)**

(All dimensions in millimetres)

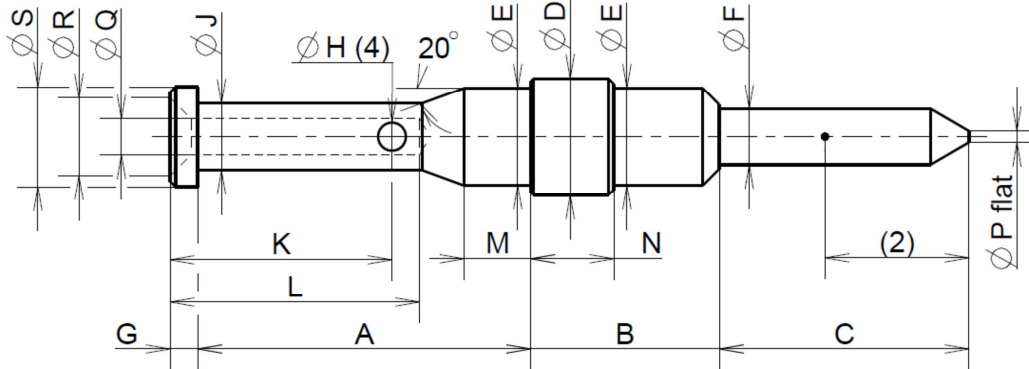

Dimension	Min	Max
A	5.95	6.05
B	3.35	3.45
C	4.35	4.65
<u>ØD</u>	2.08	2.12
ØE	1.73	1.77
<u>ØF</u>	0.99	1.04
G	0.45	0.55
ØH	0.45	0.55
ØJ	1.15	1.2

Dimension	Min	Max
K	3.9	4.1
L	4.4	4.7
M	1.1	1.3
N	1.4	1.6
ØP	-	0.3
<u>ØQ</u>	0.59	0.66
R	1.3	1.5
S	1.8	1.9

NOTES:

1. Underlined dimensions in table are critical to ensure intermateability and interchangeability.
2. Measurement point for plating thickness: 2.5 ± 1 mm.
3. ØJ, ØQ and ØS shall be concentric within 0.04mm.
4. Inspection hole shall only penetrate one wall of the crimp barrel.

4 REQUIREMENTS

4.1 GENERAL

The complete requirements for procurement of the accessories specified herein shall be as stated in this specification and ESCC Generic Specification No. 3401. Deviations from the Generic Specification, applicable to this specification only, are listed in Para 4.2.

Deviations from the Generic Specification and this Detail Specification, formally agreed with specific Manufacturers on the basis that the alternative requirements are equivalent to the ESCC requirements and do not affect the components' reliability, are listed in the appendices attached to this specification.

4.2 DEVIATIONS FROM GENERIC SPECIFICATION

4.2.1 Deviations from Special In-Process Controls

None.

4.2.2 Deviations from Final Production Tests (Chart II)

Only the following tests shall be performed:

- (a) Para. 9.2, Mating Verification.
- (b) Para. 9.5, Magnetism Level.
- (c) Para. 9.6, Dimension Check.
- (d) Para. 9.7, External Visual Inspection. The magnification shall be x3.
- (e) Para. 4.3.4 of this Specification, Locking/Unlocking Forces.

4.2.3 Deviations from Burn-in and Electrical Measurements (Chart III)

Not applicable.

4.2.4 Deviations from Qualification Tests (Chart IV)

Qualification testing shall be performed in accordance with the following Chart. No failures are allowed. Unless otherwise specified, paragraph numbers refer to the ESCC Generic Specification No. 3401.

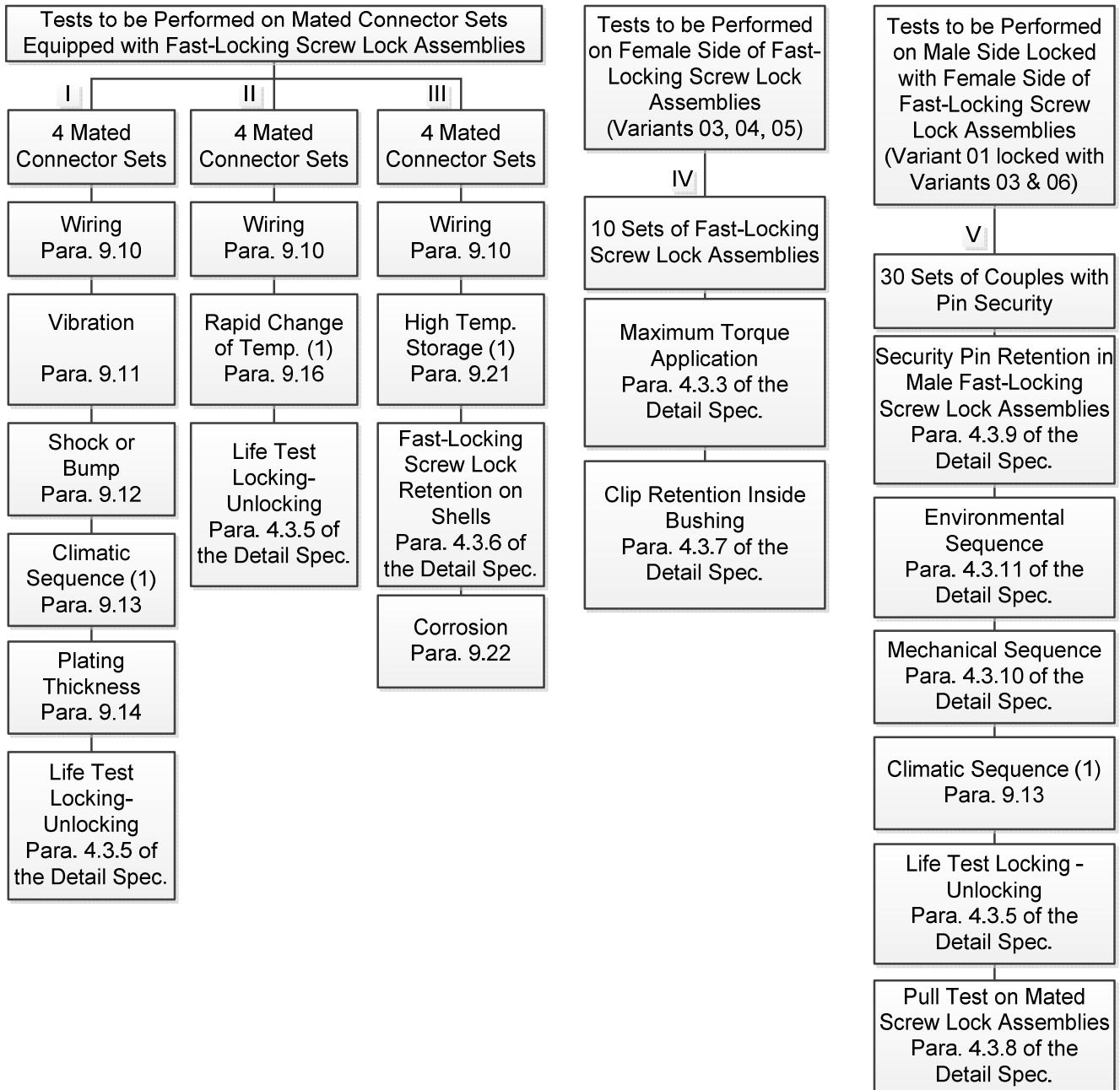

NOTES:

1. Only the measurements and inspections specified in Table 6 of the Detail Specification shall be performed.

4.2.5 Deviations from Lot Acceptance Tests (Chart V)

Lot Acceptance testing shall be performed in accordance with the following Chart. Unless otherwise specified, paragraph numbers refer to the ESCC Generic Specification No. 3401.

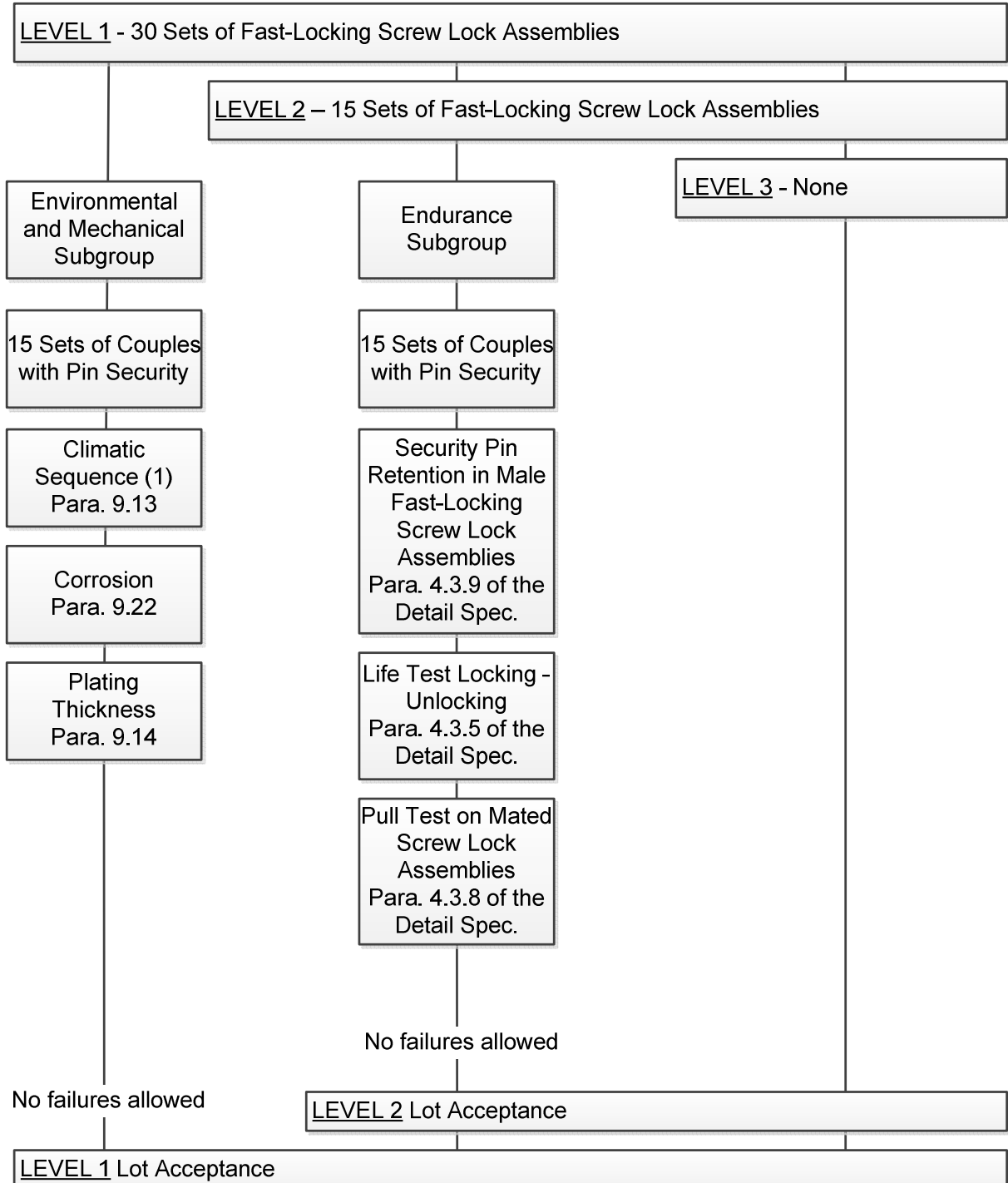

NOTES:

1. Only the measurements and inspections specified in Table 6 of the Detail Specification shall be performed.

4.3 MECHANICAL REQUIREMENTS

4.3.1 Dimension Check

The dimensions of the accessories specified herein shall be verified in accordance with the requirements set out in Para. 9.6 of ESCC Generic Specification No. 3401 and shall conform to those shown in Figure 2 of this specification.

4.3.2 Weight

The maximum weight of the accessories specified herein shall be as shown in Table 1(a) of this specification.

4.3.3 Maximum Torque Application

This test shall be performed on Variants 03 and 05.

The torque value specified in Table 6 shall be used to tighten the nuts and/or bushing of the screw locks under test. The nuts and/or bushing shall then be removed.

- **Data Points:**
The components shall be visually examined both before and after removal, and shall show no evidence of physical damage.

4.3.3.1 Coupling Nut Unlocking Torque

This test shall be performed on Variants 03 and 05.

The maximum torque value specified in Table 1(b) shall be used to tighten the screw lock under test into the bushing. The screw lock shall then be removed.

- **Data Points:**
The torque required to remove the screwlock from the bushing shall be measured and recorded and the drift calculated, if specified.

4.3.4 Locking/Unlocking Forces

This test shall be performed on Variants 01, 02 and 04.

The screw locks under test shall be put on appropriate equipment that reproduces the opposite side and ensures a mated spacing between shell front surfaces as defined in Figure 2. The locking operation is performed with the applicable test tool defined as follows:

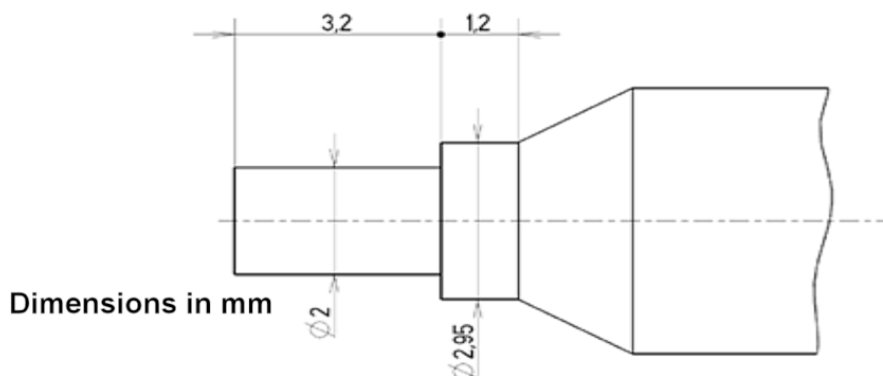

The locking speed shall be 5mm/s maximum.

The locking force is defined as the maximum force registered during the travel.

The unlocking operation is performed with the applicable test tool defined as follows:

Unlocking Tool for Variants 01, 02

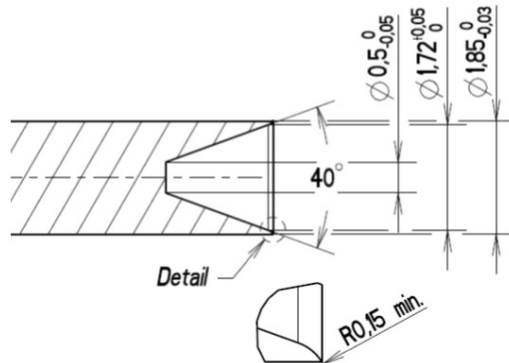

Unlocking Tool for Variant 04

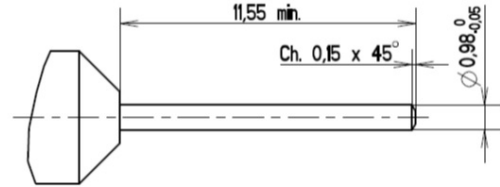

Dimensions in mm

The unlocking speed shall be 5mm/s maximum.

NOTE:

Where the screw locks under test have a Security Pin (Variant 06) engaged, the Security Pin shall be removed prior to performing the Locking/Unlocking Forces test using the installing and removal tool M81969/39-01 in accordance with MIL-DTL-81969/39, or equivalent.

The unlocking force is defined as the maximum force registered during the test.

- **Data Points:**
 For Final Production Test, the locking and unlocking forces shall be measured and recorded, and shall meet the requirements of Table 1(a).
 For Qualification and Lot Acceptance Tests, the locking and unlocking forces shall be measured and recorded, and shall meet the requirements of Table 6.

4.3.5 Life Test Locking – Unlocking

This test shall be performed on Variants 01, 02, 03, 04 and 05.

Procedure:

The screw locks under test shall be put on appropriate equipment that reproduces the opposite side and ensures a mated spacing between shell front surfaces as defined in Figure 2. The screw locks shall be subjected to 50 cycles (for both Qualification (Chart IV) and Lot Acceptance (Chart V) testing) with the tools defined in Para. 4.3.4.

A cycle is defined as one locking and one unlocking.

The male and female screw locks shall be completely separated during each cycle.

The locking speed shall be 5mm/s maximum.

The cycling rate shall be 8 cycles/minute maximum.

- **Data Points:**
 Prior to testing, the locking and unlocking forces shall be measured and recorded, and shall meet the requirements of Table 6.
 On completing of testing, the components shall be visually examined and shall show no evidence of physical damage. Locking and unlocking forces shall be measured and recorded, and shall meet the requirements of Table 6.

4.3.6 Fast-Locking Screw Lock Retention on Shells

This test shall be performed on Variants 01 and 02.

The male screw lock mounted on a connector as defined in ESCC 3401/001 Figure 2 shall be subjected to an axial force, F , of 20N for a duration of 5s, as follows:

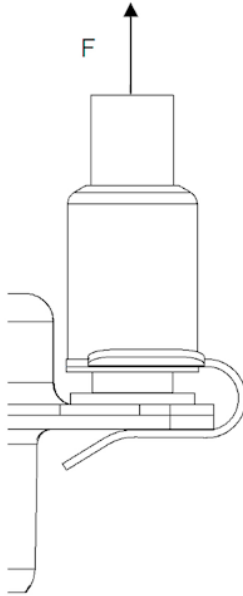

- **Data Points:**
On completion of testing, the components shall be visually examined and shall show no evidence of physical damage and the screw lock shall not be dislodged from the shell.

4.3.7 Clip Retention Inside Bushing

This test shall be performed on Variants 03, 04 and 05.

The clip inside the female screw lock shall be subjected to an axial force, F , of 150N for a duration of 5s, as follows:

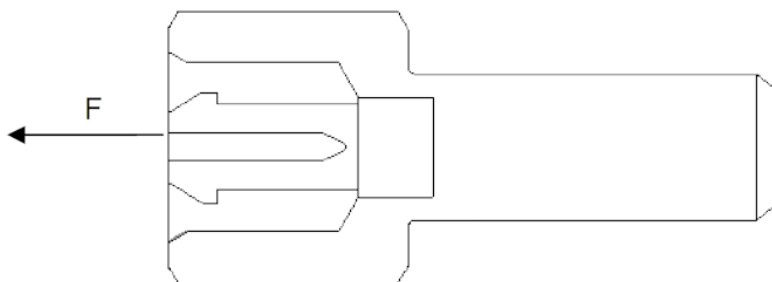

- **Data Points:**
On completion of testing, the components shall be visually examined. The clip shall not be dislodged from the bushing.

4.3.8 Pull Test on Mated Screw Lock Assemblies

This test shall be performed on Variants 01 (or 02), 03 and 06 (male and female screw locks locked together with the Security Pin engaged).

The Screw Lock assembly shall be mounted on a suitable test fixture as indicated below, that simulates assembly on mated connectors.

The screw lock assembly shall be subjected to a pull test with the following conditions (non-cumulative tests):

Pull Test 1:

- Force applied: 150N
- Duration: 5s
- Direction: 90° to mounting plane (see figure below)

Pull Test 2:

- Force applied: 50N
- Duration: 5s
- Direction: 45° to mounting plane (configuration i – see figure below)

Pull Test 3:

- Force applied: 50N
- Duration: 5s
- Direction: 45° to mounting plane (configuration ii – see figure below)

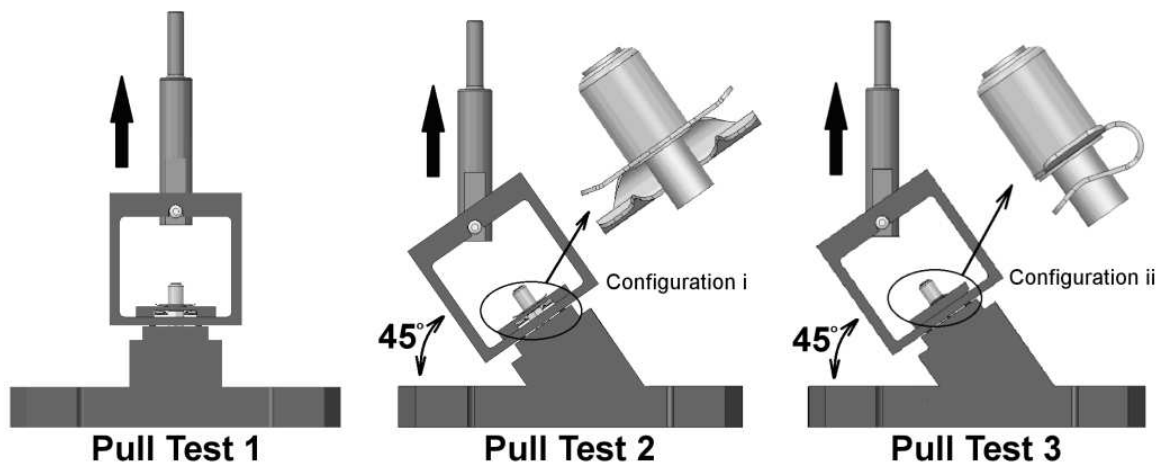

- **Data Points:**
Prior to testing, the locking and unlocking forces shall be measured and recorded, and shall meet the requirements of Table 6.
On completing of testing, the components shall be visually examined and shall show no evidence of physical damage. Locking and unlocking forces shall be measured and recorded, and shall meet the requirements of Table 6.

4.3.9 Security Pin Retention in Male Fast-Locking Screw Lock Assemblies

This test shall be performed on Variants 01 (or 02), 03 and 06 (male and female screw locks locked together with the Security Pin engaged).

The Security Pin (Variant 06) shall be subjected to an axial force, F , of 40N for a duration of 5s, as follows:

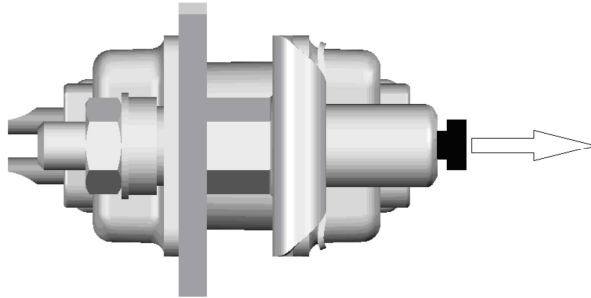

- **Data Points:**
 Prior to testing, the locking and unlocking forces shall be measured and recorded, and shall meet the requirements of Table 6.
 On completion of testing, the components shall be visually examined and shall show no evidence of physical damage and the Security Pin shall not be dislodged from the male insert of the screw lock. Locking and unlocking forces shall be measured and recorded, and shall meet the requirements of Table 6.

4.3.10 Mechanical Sequence

This test shall be performed on Variants 01, 03 and 06 (male and female screw locks locked together with the Security Pin engaged).

Procedure:

The Screw Lock assembly shall be mounted on a suitable test fixture as indicated below and subjected to Sinusoidal and Random Vibration followed by Shock or Bump in accordance with Para. 9.11 and 9.12 respectively, of ESCC Generic Specification No. 3401.

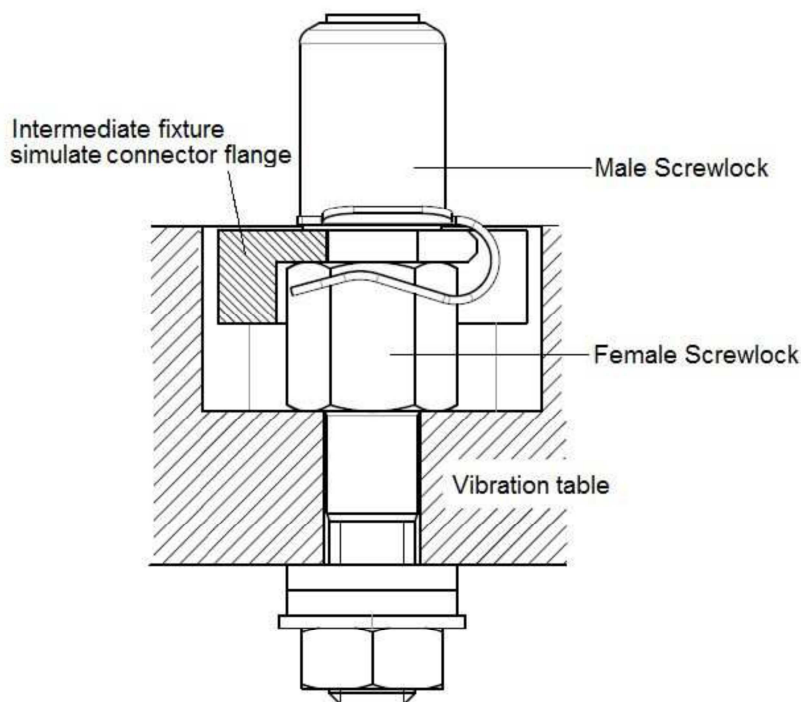

- **Data Points:**
Prior to testing, the locking and unlocking forces shall be measured and recorded, and shall meet the requirements of Table 6.
On completion of Vibration, without being unmounted, the components shall be visually examined and shall show no evidence of physical damage
On completion of Shock or Bump, the components shall be visually examined and shall show no evidence of physical damage. Locking and unlocking forces shall be measured and recorded, and shall meet the requirements of Table 6.

4.3.11 Environmental Sequence

This test shall be performed on Variants 01, 03 and 06 (male and female screw locks locked together with the Security Pin engaged).

Procedure:

The Screw Lock assembly shall be mounted on a suitable test fixture as indicated in Para. 4.3.10 and subjected to Rapid Change of Temperature followed by High Temperature Storage in accordance with Para. 9.16 and 9.21 respectively, of ESCC Generic Specification No. 3401.

- **Data Points:**
Prior to testing, the locking and unlocking forces shall be measured and recorded, and shall meet the requirements of Table 6.
On completion of Rapid Change of Temperature, without being unmounted, the components shall be visually examined and shall show no evidence of physical damage
On completion of High Temperature Storage, the components shall be visually examined and shall show no evidence of physical damage. Locking and unlocking forces shall be measured and recorded, and shall meet the requirements of Table 6.

4.4 MATERIALS AND FINISHES

The materials and finishes shall be as specified herein. Where a definite material is not specified, a material which will enable the components specified herein to meet the performance requirements of this specification shall be used. Acceptance or approval of any constituent material does not guarantee acceptance of the finished product.

4.4.1 Fast-Locking Screw Lock Assemblies

The body shall be made of brass with gold (0.7 μ m minimum) over copper (1 μ m minimum) plating.

The button shall be made of passivated stainless steel.

The spring washer (as required) shall be made of beryllium copper with gold (0.7 μ m minimum) over copper (1 μ m minimum) plating.

The spring and retaining clip (as required) shall be made of beryllium copper.

The Security Pin (Variant 06) shall be made of copper alloy with gold (0.7 μ m minimum) over copper (1 μ m minimum) plating.

4.4.2 Magnetism Level

The allowable value of magnetism shall not exceed that specified for the relevant level (see Para. 4.5.2.1(a)).

4.5 MARKING

4.5.1 General

The marking of all components delivered to this specification shall be in accordance with the requirements of ESCC Basic Specification No. 21700 and the following paragraphs.

When the component is too small to accommodate all of the marking specified, as much as space permits shall be marked and the marking information, in full, shall accompany each component in its primary package.

The information to be marked, and the order of precedence, shall be as follows:

- (a) The ESCC qualified components symbol (for ESCC qualified components only).
- (b) The ESCC Component Number (including Characteristics)
- (c) Traceability Information.

4.5.2 The ESCC Component Number

The ESCC Component Number shall be constituted and marked as follows:

Example: 340108501BNMB

- Detail Specification Number: 3401085
- Type Variant (see Table 1(a)): 01 (as required)
- Testing Level: B (Note: this is mandatory, as Testing Level 'C' is not applicable).
- Characteristic code: Magnetism Level (≤ 200 gamma): NMB (as required)

4.5.2.1 *Characteristics*

The characteristic to be codified as part of the ESCC Component Number shall be as follows:

- (a) Magnetism Level expressed by means of the following codes:

Code	Definition
NMA	Magnetism Level: ≤ 2000 gamma
NMB	Magnetism Level: ≤ 200 gamma

4.5.3 Traceability Information

Traceability information shall be marked in accordance with ESCC Basic Specification No. 21700.

4.6 ELECTRICAL MEASUREMENTS

Not applicable.

4.7 BURN-IN AND ELECTRICAL MEASUREMENTS

Not applicable.

4.8 ENVIRONMENTAL AND ENDURANCE TESTS

4.8.1 Measurements and Inspections on Completion of Environmental Tests

The parameters to be measured and inspections to be performed on completion of environmental testing are scheduled in Table 6. Unless otherwise specified, these measurements shall be performed at $T_{amb} = +22 \pm 3^{\circ}\text{C}$.

4.8.2 Measurements and Inspections at Intermediate Points During Endurance Tests

Not applicable.

- 4.8.3 Measurements and Inspections on Completion of Endurance Tests
 The parameters to be measured and inspections to be performed on completion of endurance tests shall be those specified in Table 6. Unless otherwise specified, these measurements shall be performed at $T_{amb} = +22 \pm 3^{\circ}\text{C}$.
- 4.8.4 Conditions for Operating Life Test (Part of Endurance Testing)
 Not applicable.
- 4.8.5 Electrical Circuits for Operating Life Test
 Not applicable.
- 4.8.6 Conditions for High Temperature Storage Test (Part of Endurance Testing)
 The requirements for the high temperature storage test are specified in Section 9 of ESCC Generic Specification No. 3401. The conditions for high temperature storage testing shall be the maximum storage temperature specified in Table 1(b) of this specification.

TABLES 2, 3, 4 AND 5

Not applicable.

TABLE 6 – MEASUREMENTS AND INSPECTIONS ON COMPLETION OF ENVIRONMENTAL TESTS AND ENDURANCE TESTING

No.	ESCC Generic Spec. No. 3401		Measurements and Inspections		Symbol	Limits		Unit
	Environmental and Endurance Tests (Note 1)	Test Method and Conditions	Identification	Conditions		Min	Max	
01	Vibration	Para. 9.11	Initial Measurements					
			Locking / Unlocking Forces	Para. 4.3.4 of this Spec.	F_{LO}, F_{UN}	Table 1(b) Items 3 & 4		N
			Coupling Nut Unlocking Torque	Para. 4.3.3.1 of this Spec.	Tqe	1	-	cm.daN
			Measurement during test					
			Contact disturbance		-	-	1	μs
			Final Measurements					
			Locking / Unlocking Forces	Para. 4.3.4 of this Spec.	F_{LO}, F_{UN}	Table 1(b) Items 3 & 4		N
Coupling Nut Unlocking Torque	Para. 4.3.3.1 of this Spec.	Tqe	1	-	cm.daN			
Coupling Nuts Locking Torque Drift	Para. 4.3.3.1 of this Spec.	ΔTqe	± 0.5		cm.daN			
Visual Examination	No damage	-	-		-			
02	Shock or Bump (Note 2)	Para. 9.12	Initial Measurements					
			Locking / Unlocking Forces	Para. 4.3.4 of this Spec.	F_{LO}, F_{UN}	Table 1(b) Items 3 & 4		N
			Measurement during test					
			Contact disturbance		-	-	1	μs
			Final Measurements					
Locking / Unlocking Forces	Para. 4.3.4 of this Spec.	F_{LO}, F_{UN}	Table 1(b) Items 3 & 4		N			
Visual Examination	No damage	-	-		-			

No.	ESCC Generic Spec. No. 3401		Measurements and Inspections		Symbol	Limits		Unit
	Environmental and Endurance Tests (Note 1)	Test Method and Conditions	Identification	Conditions		Min	Max	
03	Climatic Sequence (Note 2)	Para. 9.13	Initial Measurements					
			Locking / Unlocking Forces	Para. 4.3.4 of this Spec.	F_{LO}, F_{UN}	Table 1(b) Items 3 & 4	N	
			Final Measurements	After 1-24 hrs Recovery				
			External Visual Inspection	ESCC 3401 Para. 9.7	-	-	-	-
			Locking / Unlocking Forces	Para. 4.3.4 of this Spec.	F_{LO}, F_{UN}	Table 1(b) Items 3 & 4	N	
04	Plating Thickness	Para. 9.14	Plating thickness		-	Para. 4.4.1 of this Spec.	μm	
05	Life Test Locking - Unlocking (Note 2)	Para. 4.3.5 of this Spec.	Initial Measurements					
			Locking / Unlocking Forces	Para. 4.3.4 of this Spec.	F_{LO}, F_{UN}	Table 1(b) Items 3 & 4	N	
			Final Measurements					
			Visual Examination	No damage	-	-	-	
			Locking / Unlocking Forces	Para. 4.3.4 of this Spec.	F_{LO}, F_{UN}	Table 1(b) Items 3 & 4	N	
06	Rapid Change of Temperature	Para. 9.16	Initial Measurements					
			Locking / Unlocking Forces	Para. 4.3.4 of this Spec.	F_{LO}, F_{UN}	Table 1(b) Items 3 & 4	N	
			Final Measurements					
			Visual Examination	No damage	-	-	-	
			Locking / Unlocking Forces	Para. 4.3.4 of this Spec.	F_{LO}, F_{UN}	Table 1(b) Items 3 & 4	N	
07	High Temperature Storage	Para. 9.21	Initial Measurements					
			Locking / Unlocking Forces	Para. 4.3.4 of this Spec.	F_{LO}, F_{UN}	Table 1(b) Items 3 & 4	N	
			Final Measurements					
			Visual Examination	No damage	-	-	-	
			Locking / Unlocking Forces	Para. 4.3.4 of this Spec.	F_{LO}, F_{UN}	Table 1(b) Items 3 & 4	N	
08	Fast-Locking Screw Lock Retention on Shells	Para. 4.3.6 of this Spec.	Visual Examination	Para. 4.3.6 of this Spec.	-	-	-	
09	Corrosion	Para. 9.22	Visual Examination	Para. 9.22	-	-	-	
10	Maximum Torque Application	Para. 4.3.3 of this Spec.	Torque Value	Para. 4.3.3 of this Spec.	T_{qe}	Table 1(b) Item 5	cm.daN	
			Visual Examination	No damage	-	-	-	
11	Clip Retention Inside Bushing	Para. 4.3.7 of this Spec.	Visual Examination	Para. 4.3.7 of this Spec.	-	-	-	
12	Pull Test on Mated Screw Lock Assemblies (Note 2)	Para. 4.3.8 of this Spec.	Initial Measurements					
			Locking / Unlocking Forces	Para. 4.3.4 of this Spec.	F_{LO}, F_{UN}	Table 1(b) Items 3 & 4	N	
			Final Measurements					
			Visual Examination	No damage	-	-	-	
			Locking / Unlocking Forces	Para. 4.3.4 of this Spec.	F_{LO}, F_{UN}	Table 1(b) Items 3 & 4	N	

No.	ESCC Generic Spec. No. 3401		Measurements and Inspections		Symbol	Limits		Unit
	Environmental and Endurance Tests (Note 1)	Test Method and Conditions	Identification	Conditions		Min	Max	
13	Security Pin Retention in Male Fast-Locking Screw Lock Assemblies	Para. 4.3.9 of this Spec.	Initial Measurements Locking / Unlocking Forces	Para. 4.3.4 of this Spec.	F_{LO}, F_{UN}	Table 1(b) Items 3 & 4		N
			Final Measurements Visual Examination Locking / Unlocking Forces	Para. 4.3.9 of this Spec. Para. 4.3.4 of this Spec.	- F_{LO}, F_{UN}	- Table 1(b) Items 3 & 4	- N	
14	Mechanical Sequence (Note 2)	Para. 4.3.10 of this Spec.	Initial Measurements Locking / Unlocking Forces	Para. 4.3.4 of this Spec.	F_{LO}, F_{UN}	Table 1(b) Items 3 & 4		N
			Intermediate Inspection Visual Examination	No damage	-	-	-	
			Final Measurements Visual Examination Locking / Unlocking Forces	No damage Para. 4.3.4 of this Spec.	- F_{LO}, F_{UN}	- Table 1(b) Items 3 & 4	- N	
14	Environmental Sequence (Note 2)	Para. 4.3.11 of this Spec.	Initial Measurements Locking / Unlocking Forces	Para. 4.3.4 of this Spec.	F_{LO}, F_{UN}	Table 1(b) Items 3 & 4		N
			Intermediate Inspection Visual Examination	No damage	-	-	-	
			Final Measurements Visual Examination Locking / Unlocking Forces	No damage Para. 4.3.4 of this Spec.	- F_{LO}, F_{UN}	- Table 1(b) Items 3 & 4	- N	

NOTES:

1. The tests in this Table refer to either Chart IV or V and shall be used as applicable (see Paras. 4.2.4 & 4.2.5 herein)
2. Locking/Unlocking Forces measurements need not be repeated in initial measurements when performed during the final measurements of the previous test.