



Page 1 of 13

TRANSISTORS, SWITCHING, PNP

BASED ON TYPE 2N3467

ESCC Detail Specification No. 5208/009

Issue 4	October 2015
---------	--------------



Document Custodian: European Space Agency – see <https://escies.org>

LEGAL DISCLAIMER AND COPYRIGHT

European Space Agency, Copyright © 2015, All rights reserved.

The European Space Agency disclaims any liability or responsibility, to any person or entity, with respect to any loss or damage caused, or alleged to be caused, directly or indirectly by the use and application of this ESCC publication.

This publication, without the prior permission of the European Space Agency and provided that it is not used for a commercial purpose, may be:

- copied in whole, in any medium, without alteration or modification.
- copied in part, in any medium, provided that the ESCC document identification, comprising the ESCC symbol, document number and document issue, is removed.

DOCUMENTATION CHANGE NOTICE

(Refer to <https://escies.org> for ESCC DCR content)

DCR No.	CHANGE DESCRIPTION
946	Specification upissued to incorporate editorial changes per DCR.

**TABLE OF CONTENTS**

1	GENERAL	5
1.1	SCOPE	5
1.2	APPLICABLE DOCUMENTS	5
1.3	TERMS, DEFINITIONS, ABBREVIATIONS, SYMBOLS AND UNITS	5
1.4	ESCC COMPONENT NUMBER AND COMPONENT TYPE VARIANTS	5
1.4.1	The ESCC Component Number	5
1.4.2	Component Type Variants	5
1.5	MAXIMUM RATINGS	6
1.6	PHYSICAL DIMENSIONS AND TERMINAL IDENTIFICATION	7
1.6.1	Metal Can Package (TO-39) - 3 lead	7
1.7	FUNCTIONAL DIAGRAM	8
1.8	MATERIALS AND FINISHES	8
2	REQUIREMENTS	8
2.1	GENERAL	8
2.1.1	Deviations from the Generic Specification	8
2.2	MARKING	9
2.3	TERMINAL STRENGTH	9
2.4	ELECTRICAL MEASUREMENTS AT ROOM, HIGH AND LOW TEMPERATURES	9
2.4.1	Room Temperature Electrical Measurements	9
2.4.2	High and Low Temperatures Electrical Measurements	11
2.5	PARAMETER DRIFT VALUES	12
2.6	INTERMEDIATE AND END-POINT ELECTRICAL MEASUREMENTS	12
2.7	HIGH TEMPERATURE REVERSE BIAS BURN-IN CONDITIONS	13
2.8	POWER BURN-IN CONDITIONS	13
2.9	OPERATING LIFE CONDITIONS	13

1 GENERAL

1.1 SCOPE

This specification details the ratings, physical and electrical characteristics and test and inspection data for the component type variants and/or the range of components specified below. It supplements the requirements of, and shall be read in conjunction with, the ESCC Generic Specification listed under Applicable Documents.

1.2 APPLICABLE DOCUMENTS

The following documents form part of this specification and shall be read in conjunction with it:

- (a) ESCC Generic Specification No. 5000
- (b) MIL-STD-750, Test Methods and Procedures for Semiconductor Devices

1.3 TERMS, DEFINITIONS, ABBREVIATIONS, SYMBOLS AND UNITS

For the purpose of this specification, the terms, definitions, abbreviations, symbols and units specified in ESCC Basic Specification No. 21300 shall apply.

1.4 ESCC COMPONENT NUMBER AND COMPONENT TYPE VARIANTS

1.4.1 The ESCC Component Number

The ESCC Component Number shall be constituted as follows:

Example: 520800901

- Detail Specification Reference: 5208009
- Component Type Variant Number: 01 (as required)

1.4.2 Component Type Variants

The component type variants applicable to this specification are as follows:

Variant Number	Based on Type	Case	Lead/Terminal Material and Finish	Weight max g
01	2N3467	TO-39	D2	1.2
02	2N3467	TO-39	D3 or D4	1.2

The lead/terminal material and finish shall be in accordance with the requirements of ESCC Basic Specification No. 23500.

1.5 MAXIMUM RATINGS

The maximum ratings shall not be exceeded at any time during use or storage.

Maximum ratings shall only be exceeded during testing to the extent specified in this specification and when stipulated in Test Methods and Procedures of the ESCC Generic Specification.

Characteristics	Symbols	Maximum Ratings	Unit	Remarks
Collector-Base Voltage	V_{CBO}	-40	V	Over entire operating temperature range
Collector-Emitter Voltage	V_{CEO}	-40	V	
Emitter-Base Voltage	V_{EBO}	-5	V	
Collector Current	I_C	-1	A	Continuous
Power Dissipation	P_{tot1}	1	W	At $T_{amb} \leq +25^{\circ}C$
	P_{tot2}	5	W	At $T_{case} \leq +25^{\circ}C$
Thermal Resistance, Junction-to-Ambient	$R_{th(j-a)}$	175	$^{\circ}C/W$	
Thermal Resistance, Junction-to-Case	$R_{th(j-c)}$	30	$^{\circ}C/W$	
Operating Temperature Range	T_{op}	-65 to +200	$^{\circ}C$	Note 1
Storage Temperature Range	T_{stg}	-65 to +200	$^{\circ}C$	Note 1
Soldering Temperature	T_{sol}	+265	$^{\circ}C$	Note 2

NOTES:

1. For Variants with tin-lead plating or hot solder dip lead finish all testing, and any handling, performed at $T_{amb} > +125^{\circ}C$ shall be carried out in a 100% inert atmosphere.
2. Duration 10 seconds maximum at a distance of not less than 1.5mm from the device body and the same lead shall not be resoldered until 3 minutes have elapsed.

1.6 PHYSICAL DIMENSIONS AND TERMINAL IDENTIFICATION

1.6.1 Metal Can Package (TO-39) - 3 lead

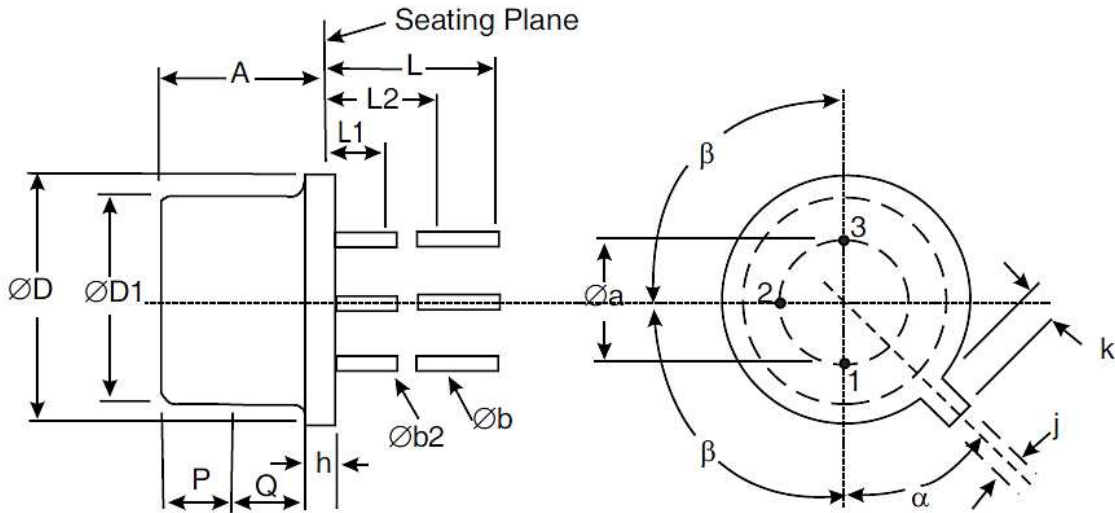

Symbols	Dimensions mm		Notes
	Min	Max	
$\varnothing a$	4.83	5.35	
A	6	6.6	
$\varnothing b$	0.4	0.533	2, 3
$\varnothing b2$	0.4	0.483	2, 3
$\varnothing D$	8.31	9.4	
$\varnothing D1$	7.75	8.51	
h	0.229	3.18	
j	0.71	0.864	
k	0.737	1.14	4
L	12.7	19	2
L1	-	1.27	2, 3
L2	6.35	-	2, 3
P	2.54	-	5
Q	-	-	6
α	45° BSC		1, 7
β	90° BSC		1

NOTES:

1. Terminal identification is specified by reference to the tab position where Lead 1 = emitter, Lead 2 = base and Lead 3 = collector.
2. Applies to all leads.
3. $\varnothing b2$ applies between L1 and L2. $\varnothing b$ applies between L1 and 12.7mm from the seating plane. Diameter is uncontrolled within L1 and beyond 12.7mm from the seating plane.
4. Measured from the maximum diameter of the actual device.
5. This zone is controlled for automatic handling. The variation in actual diameter within this zone shall not exceed 0.254mm.

6. The details of outline in this zone are optional.
7. Measured from the Tab Centreline.

1.7 FUNCTIONAL DIAGRAM

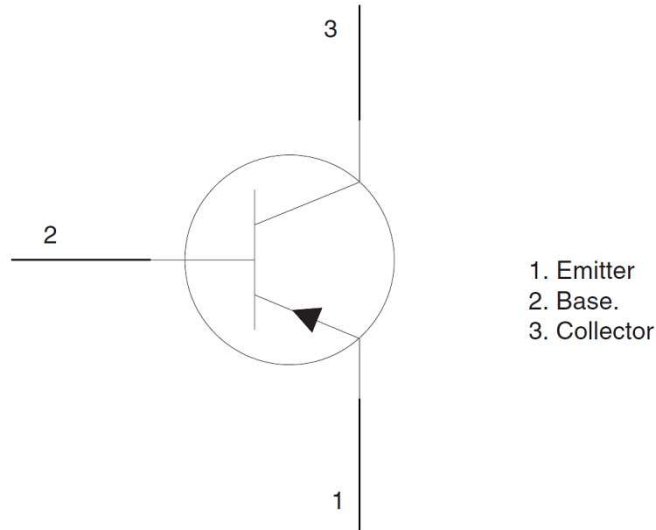

NOTES:

1. The collector is internally connected to the case.

1.8 MATERIALS AND FINISHES

Materials and finishes shall be as follows:

- (a) Case
The case shall be hermetically sealed and have a metal body with hard glass seals.
- (b) Leads/Terminals
As specified in Component Type Variants.

2 REQUIREMENTS

2.1 GENERAL

The complete requirements for procurement of the components specified herein are as stated in this specification and the ESCC Generic Specification. Permitted deviations from the Generic Specification, applicable to this specification only, are listed below.

Permitted deviations from the Generic Specification and this Detail Specification, formally agreed with specific Manufacturers on the basis that the alternative requirements are equivalent to the ESCC requirement and do not affect the component's reliability, are listed in the appendices attached to this specification.

2.1.1 Deviations from the Generic Specification

None.

2.2 MARKING

The marking shall be in accordance with the requirements of ESCC Basic Specification No. 21700 and as follows.

The information to be marked on the component shall be:

- (a) The ESCC qualified components symbol (for ESCC qualified components only).
- (b) The ESCC Component Number.
- (c) Traceability information.

2.3 TERMINAL STRENGTH

The test conditions for terminal strength, tested as specified in the ESCC Generic Specification, shall be as follows:

Test Condition: E, lead fatigue.

2.4 ELECTRICAL MEASUREMENTS AT ROOM, HIGH AND LOW TEMPERATURES

Electrical measurements shall be performed at room, high and low temperatures.

2.4.1 Room Temperature Electrical Measurements

The measurements shall be performed at $T_{amb} = +22 \pm 3^{\circ}\text{C}$.

Characteristics	Symbols	MIL-STD-750 Test Method	Test Conditions	Limits		Units
				Min	Max	
Collector-Base Breakdown Voltage	$V_{(BR)CBO}$	3001	$I_C = -10\mu\text{A}$ Bias condition D	-40	-	V
Collector-Emitter Breakdown Voltage	$V_{(BR)CEO}$	3011	$I_C = -10\text{mA}$ Bias condition D Note 1	-40	-	V
Emitter-Base Breakdown Voltage	$V_{(BR)EBO}$	3026	$I_E = -10\mu\text{A}$ Bias condition D	-5	-	V
Collector-Emitter Cut-off Current	I_{CEX}	3041	$V_{BE} = -3\text{V}, V_{CE} = -30\text{V}$ Bias condition A	-	-100	nA
Collector-Base Cut-off Current	I_{CBO}	3036	$V_{CB} = -30\text{V}$ Bias condition D	-	-100	nA
Forward-Current Transfer Ratio	h_{FE1}	3076	$V_{CE} = -1\text{V}, I_C = -150\text{mA}$ Note 1	40	-	-
	h_{FE2}	3076	$V_{CE} = -1\text{V}, I_C = -500\text{mA}$ Note 1	40	120	-
	h_{FE3}	3076	$V_{CE} = -5\text{V}, I_C = -1\text{A}$ Note 1	40	-	-
Collector-Emitter Saturation Voltage	$V_{CE(sat)1}$	3071	$I_C = -150\text{mA}, I_B = -15\text{mA}$ Note 1	-	-350	mV
	$V_{CE(sat)2}$	3071	$I_C = -500\text{mA}, I_B = -50\text{mA}$ Note 1	-	-600	mV
	$V_{CE(sat)3}$	3071	$I_C = -1\text{mA}, I_B = -100\text{mA}$ Note 1	-	-1.2	V

Characteristics	Symbols	MIL-STD-750 Test Method	Test Conditions	Limits		Units
				Min	Max	
Base-Emitter Saturation Voltage	$V_{BE(sat)1}$	3066	$I_C = -150mA, I_B = -15mA$ Test Condition A Note 1	-	-1	V
	$V_{BE(sat)2}$	3066	$I_C = -500mA, I_B = -50mA$ Test Condition A Note 1	-	-1.2	V
	$V_{BE(sat)3}$	3066	$I_C = -1A, I_B = -100mA$ Test Condition A Note 1	-	-1.6	V
Small-Signal Short-Circuit Forward-Current Transfer Ratio	h_{fe}	3306	$I_C = -50mA, V_{CE} = -10V$ $f = 100MHz$ Note 2	1.8	-	-
Output Capacitance	C_{obo}	3236	$V_{CB} = -10V, I_E = 0A$ $f = 100kHz$ Note 2	-	25	pF
Input Capacitance	C_{ibo}	3240	$V_{EB} = -500mV, I_C = 0A$ $f = 100kHz$ Note 2	-	100	pF
Delay Time	t_d	-	$I_C = -500mA, I_{B1} = -50mA$ $V_{BE} = -2V, V_{CE} = -30V$ Notes 2, 3	-	10	ns
Rise Time	t_r	-	$I_C = -500mA, I_{B1} = -50mA$ $V_{BE} = -2V, V_{CE} = -30V$ Notes 2, 3	-	30	ns
Storage Time	t_s	-	$I_C = -500mA$ $I_{B1} = I_{B2} = -50mA$ $V_{CC} = -30V$ Notes 2, 4	-	60	ns
Fall Time	t_f	-	$I_C = -500mA$ $I_{B1} = I_{B2} = -50mA$ $V_{CC} = -30V$ Notes 2, 4	-	30	ns

NOTES:

1. Pulsed measurement: Pulse Width $\leq 2\mu s$, Duty Cycle $\leq 1\%$.
2. For AC characteristics read and record measurements shall be performed on a sample of 32 components with 0 failures allowed. Alternatively a 100% inspection may be performed.
3. t_d and t_r shall be measured using the following test circuit. The input waveform shall be supplied by a pulse generator with the following characteristics: $Z_{OUT} = 50\Omega$, $t_r = t_f \leq 2ns$, Pulse Width = 200ns, Duty Cycle = 2%. The output waveform shall be monitored on an oscilloscope with the following characteristics: $Z_{IN} \geq 100k\Omega$, $t_r \leq 200ps$, $C_{IN} \leq 12pF$.

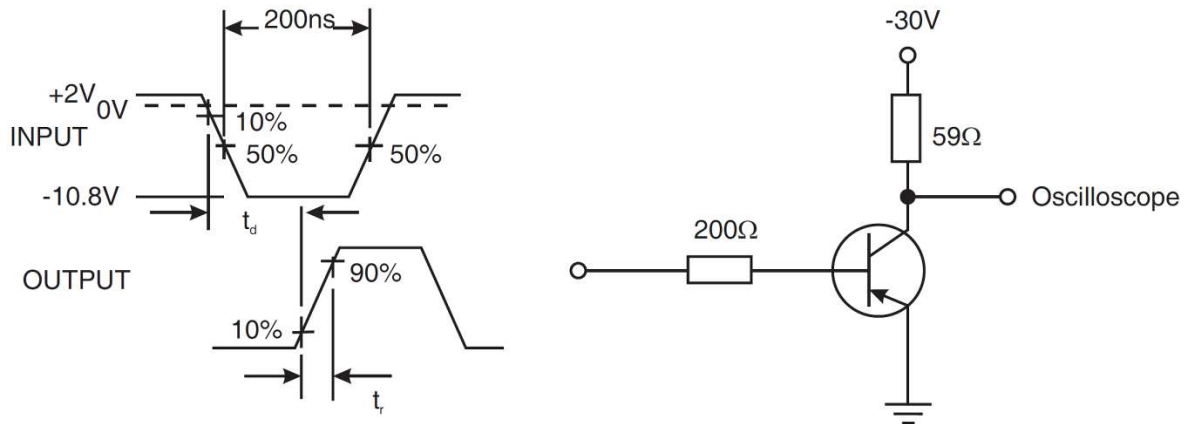

4. t_s and t_f shall be measured using the following test circuit. The input waveform shall be supplied by a pulse generator with the following characteristics: $Z_{OUT} = 50\Omega$, $10\mu s \leq$ Pulse Width $\leq 500\mu s$, $t_r = t_f \leq 2ns$, Duty Cycle = 2%. The output waveform shall be monitored on an oscilloscope with the following characteristics: $Z_{IN} \geq 100k\Omega$, $t_r \leq 200ps$, $C_{in} \leq 12pF$.

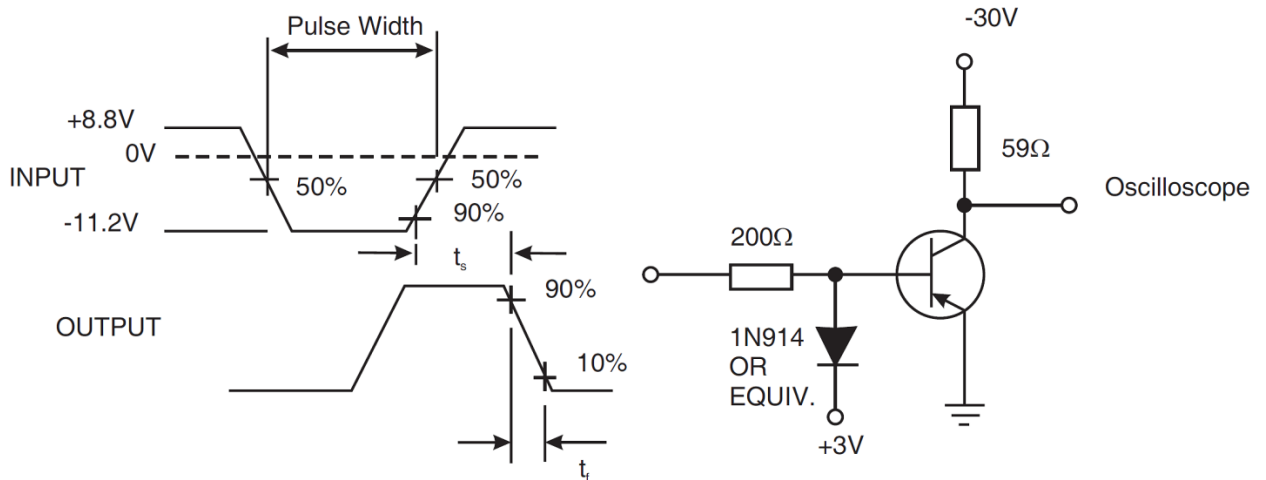

2.4.2 High and Low Temperatures Electrical Measurements

Characteristics	Symbols	MIL-STD-750 Test Method	Test Conditions Note 1	Limits		Units
				Min	Max	
Collector-Base Cut-off Current	I_{CBO}	3036	$T_{amb} = +150 (+0 -5)^{\circ}C$ $V_{CB} = -30V$ Bias condition D	-	-50	μA
Forward-Current Transfer Ratio 1	h_{FE1}	3076	$T_{amb} = -55 (+5 -0)^{\circ}C$ $V_{CE} = -1V$, $I_C = -150mA$ Note 2	16	-	-

NOTES:

1. Read and record measurements shall be performed on a sample of 5 components with 0 failures allowed. Alternatively a 100% inspection may be performed.
2. Pulsed measurement: Pulse Width $\leq 2\mu s$, Duty Cycle $\leq 1\%$.

2.5 PARAMETER DRIFT VALUES

Unless otherwise specified, the measurements shall be performed at $T_{amb} = +22 \pm 3^{\circ}\text{C}$.

The test methods and test conditions shall be as per the corresponding test defined in Room Temperature Electrical Measurements.

The drift values (Δ) shall not be exceeded for each characteristic specified. The corresponding absolute limit values for each characteristic shall not be exceeded.

Characteristics	Symbols	Limits		Units	
		Drift Value Δ	Absolute		
			Min		Max
Collector-Base Cut-off Current	I_{CBO}	± 30 or (1) $\pm 100\%$	-	-100	nA
Forward-Current Transfer Ratio 2	h_{FE2}	$\pm 15\%$	40	120	-
Collector-Emitter Saturation Voltage 1	$V_{CE(sat)1}$	± 50 or (1) $\pm 15\%$	-	-350	mV

NOTES:

1. Whichever is the greater referred to initial value.

2.6 INTERMEDIATE AND END-POINT ELECTRICAL MEASUREMENTS

Unless otherwise specified, the measurements shall be performed at $T_{amb} = +22 \pm 3^{\circ}\text{C}$.

The test methods and test conditions shall be as per the corresponding test defined in Room Temperature Electrical Measurements.

The limit values for each characteristic shall not be exceeded.

Characteristics	Symbols	Limits		Units
		Min	Max	
Collector-Base Cut-off Current	I_{CBO}	-	-100	nA
Forward-Current Transfer Ratio 2	h_{FE2}	40	120	-
Collector-Emitter Saturation Voltage 2	$V_{CE(sat)2}$	-	-600	mV

2.7 HIGH TEMPERATURE REVERSE BIAS BURN-IN CONDITIONS

Characteristics	Symbols	Test Conditions	Units
Ambient Temperature	T_{amb}	+150 (+0 -5)	°C
Collector-Base Voltage	V_{CB}	-30	V
Duration	t	48 minimum	Hours

2.8 POWER BURN-IN CONDITIONS

Characteristics	Symbols	Test Conditions	Units
Ambient Temperature	T_{amb}	+22 ±3	°C
Power Dissipation	P_{tot}	1	W
Collector-Base Voltage	V_{CB}	-30	V

2.9 OPERATING LIFE CONDITIONS

The conditions shall be as specified for Power Burn-in.