



**INTEGRATED CIRCUITS, SILICON MONOLITHIC,  
CMOS, CELL-BASED ARRAY  
BASED ON TYPE ATC18RHA**

**ESCC Detail Specification No. 9202/080**

Issue 4	February 2016
---------	---------------



### **LEGAL DISCLAIMER AND COPYRIGHT**

European Space Agency, Copyright © 2016. All rights reserved.

The European Space Agency disclaims any liability or responsibility, to any person or entity, with respect to any loss or damage caused, or alleged to be caused, directly or indirectly by the use and application of this ESCC publication.

This publication, without the prior permission of the European Space Agency and provided that it is not used for a commercial purpose, may be:

- copied in whole, in any medium, without alteration or modification.
- copied in part, in any medium, provided that the ESCC document identification, comprising the ESCC symbol, document number and document issue, is removed.

**DOCUMENTATION CHANGE NOTICE**

(Refer to <https://escies.org> for ESCC DCR content)

DCR No.	CHANGE DESCRIPTION
954	Specification upissued to incorporate technical changes per DCR.

**TABLE OF CONTENTS**

1	GENERAL	6
1.1	SCOPE	6
1.2	APPLICABLE DOCUMENTS	6
1.3	TERMS, DEFINITIONS, ABBREVIATIONS, SYMBOLS AND UNITS	6
1.4	THE ESCC COMPONENT NUMBER AND COMPONENT TYPE VARIANTS	6
1.4.1	The ESCC Component Number	6
1.4.2	Component Type Variants	6
1.4.3	Manufacturer Specific ASIC Identification	10
1.5	MAXIMUM RATINGS	10
1.6	HANDLING PRECAUTIONS	11
1.7	PHYSICAL DIMENSIONS AND TERMINAL IDENTIFICATION	12
1.7.1	Multilayer Quad Flat Package (MQFP-F160) - 160 Flat Leads	12
1.7.2	Multilayer Quad Flat Package (MQFP-F196) - 196 Flat Leads	13
1.7.3	Multilayer Quad Flat Package (MQFP-F256) - 256 Flat Leads	14
1.7.4	Multilayer Quad Flat Package (MQFP-T352) - 352 Tied Leads	15
1.7.5	Land Grid Array (LGA-349) - 349 Pads	17
1.7.6	Land Grid Array (LGA-472) - 472 Pads	19
1.7.7	Land Grid Array (LGA-625) - 625 Pads	20
1.7.8	Land Grid Array (AIN LGA-625) - 625 Pads	22
1.7.9	Multilayer Column Grid Array (MCGA-349) - 349 Columns	24
1.7.10	Multilayer Column Grid Array (MCGA-472) - 472 Columns	25
1.8	FUNCTIONAL DIAGRAM	26
1.9	PIN ASSIGNMENT	26
1.10	INSTRUCTION SET AND TIMING DIAGRAMS	26
2	REQUIREMENTS	26
2.1	GENERAL	26
2.1.1	Deviations from the Generic Specification	26
2.1.1.1	Deviations from Screening Tests	26
2.2	MARKING	27
2.3	ELECTRICAL MEASUREMENTS AT ROOM, HIGH AND LOW TEMPERATURES	27
2.3.1	Room Temperature Electrical Measurements	27
2.3.1.1	Room Temperature Electrical Measurements for Components Specified at Supply Voltage $V_{CC} = 3.3V$ (Variants 01 to 23)	27
2.3.1.2	Room Temperature Electrical Measurements for Components Specified at Supply Voltage $V_{CC} = 2.5V$ (Variants 24 to 46)	29
2.3.2	Notes to Electrical Measurements Tables	31



2.3.3	High and Low Temperatures Electrical Measurements	31
2.4	PARAMETER DRIFT VALUES	31
2.5	INTERMEDIATE AND END-POINT ELECTRICAL MEASUREMENTS	31
2.6	POWER BURN-IN CONDITIONS	32
2.7	OPERATING LIFE CONDITIONS	32
2.8	TOTAL DOSE RADIATION TESTING	32
2.8.1	Bias Conditions and Total Dose Level for Total Dose Radiation Testing	32
2.8.2	Electrical Measurements for Total Dose Radiation Testing	32

**1 GENERAL**

**1.1 SCOPE**

This specification details the ratings, physical and electrical characteristics and test and inspection data for the component type variants and/or the range of components specified below. It supplements the requirements of, and shall be read in conjunction with, the ESCC Generic Specification listed under Applicable Documents.

**1.2 APPLICABLE DOCUMENTS**

The following documents form part of this specification and shall be read in conjunction with it:

- (a) ESCC Generic Specification No. 9000.
- (b) MIL-STD-883, Test Methods and Procedures for Microelectronics.

**1.3 TERMS, DEFINITIONS, ABBREVIATIONS, SYMBOLS AND UNITS**

For the purpose of this specification, the terms, definitions, abbreviations, symbols and units specified in ESCC Basic Specification No. 21300 shall apply.

**1.4 THE ESCC COMPONENT NUMBER AND COMPONENT TYPE VARIANTS**

**1.4.1 The ESCC Component Number**

The ESCC Component number shall be constituted as follows:

Example: 920208001RXYZ

- Detail Specification Reference: 9202080
- Component Type Variant Number: 01 (as required)
- Total Dose Radiation Level Letter: R (as required)
- Manufacturer Specific ASIC Identification: XYZ (as applicable) where:  
XYZ : Individual 3 character code allocated by the Manufacturer to a specific ASIC design.

**1.4.2 Component Type Variants**

The component type variants applicable to this specification are as follows:

Variant Number	Based on Type	Typical Equivalent NAND2 Gate Count	Interface Circuitry Supply Voltage (Note 1)	Case	Terminal Material and Finish	Weight max g	Total Dose Radiation Level Letter (Note 5)
01	ATC18RHA95_216	1M	3.3V	MQFP-F256	D2 (Note 2)	14	R [100kRAD(Si)]
02	ATC18RHA95_216	1M	3.3V	MQFP-F196	D2 (Note 2)	10	R [100kRAD(Si)]
03	ATC18RHA95_216	1M	3.3V	MQFP-F160	D2 (Note 2)	7	R [100kRAD(Si)]

Variant Number	Based on Type	Typical Equivalent NAND2 Gate Count	Interface Circuitry Supply Voltage (Note 1)	Case	Terminal Material and Finish	Weight max g	Total Dose Radiation Level Letter (Note 5)
04	ATC18RHA95_324	2.2M	3.3V	MQFP-T352	D2 (Note 2)	27	R [100kRAD(Si)]
05	ATC18RHA95_324	2.2M	3.3V	MQFP-F256	D2 (Note 2)	14	R [100kRAD(Si)]
06	ATC18RHA95_324	2.2M	3.3V	MQFP-F196	D2 (Note 2)	10	R [100kRAD(Si)]
07	ATC18RHA95_324	2.2M	3.3V	MQFP-F160	D2 (Note 2)	7	R [100kRAD(Si)]
08	ATC18RHA95_324	2.2M	3.3V	LGA-349	(Note 3)	7	R [100kRAD(Si)]
09	ATC18RHA95_404	3.5M	3.3V	MQFP-T352	D2 (Note 2)	27	R [100kRAD(Si)]
10	ATC18RHA95_404	3.5M	3.3V	MQFP-F256	D2 (Note 2)	14	R [100kRAD(Si)]
11	ATC18RHA95_404	3.5M	3.3V	LGA-625	(Note 3)	9	R [100kRAD(Si)]
12	ATC18RHA95_404	3.5M	3.3V	AIN LGA-625	(Note 4)	29	R [100kRAD(Si)]
13	ATC18RHA95_404	3.5M	3.3V	LGA-472	(Note 3)	9	R [100kRAD(Si)]
14	ATC18RHA95_404	3.5M	3.3V	LGA-349	(Note 3)	7	R [100kRAD(Si)]
15	ATC18RHA95_504	5.5M	3.3V	MQFP-T352	D2 (Note 2)	27	R [100kRAD(Si)]
16	ATC18RHA95_504	5.5M	3.3V	MQFP-F256	D2 (Note 2)	14	R [100kRAD(Si)]
17	ATC18RHA95_504	5.5M	3.3V	LGA-625	(Note 3)	9	R [100kRAD(Si)]
18	ATC18RHA95_504	5.5M	3.3V	AIN LGA-625	(Note 4)	29	R [100kRAD(Si)]
19	ATC18RHA95_504	5.5M	3.3V	LGA-472	(Note 3)	9	R [100kRAD(Si)]
20	ATC18RHA95_504	5.5M	3.3V	LGA-349	(Note 3)	7	R [100kRAD(Si)]
21	ATC18RHA95_544	6.5M	3.3V	LGA-625	(Note 3)	9	R [100kRAD(Si)]

Variant Number	Based on Type	Typical Equivalent NAND2 Gate Count	Interface Circuitry Supply Voltage (Note 1)	Case	Terminal Material and Finish	Weight max g	Total Dose Radiation Level Letter (Note 5)
22	ATC18RHA95_544	6.5M	3.3V	AIN LGA-625	(Note 4)	29	R [100kRAD(Si)]
23	ATC18RHA95_544	6.5M	3.3V	LGA-472	(Note 3)	9	R [100kRAD(Si)]
24	ATC18RHA95_216	1M	2.5V	MQFP-F256	D2 (Note 2)	14	R [100kRAD(Si)]
25	ATC18RHA95_216	1M	2.5V	MQFP-F196	D2 (Note 2)	10	R [100kRAD(Si)]
26	ATC18RHA95_216	1M	2.5V	MQFP-F160	D2 (Note 2)	7	R [100kRAD(Si)]
27	ATC18RHA95_324	2.2M	2.5V	MQFP-T352	D2 (Note 2)	27	R [100kRAD(Si)]
28	ATC18RHA95_324	2.2M	2.5V	MQFP-F256	D2 (Note 2)	14	R [100kRAD(Si)]
29	ATC18RHA95_324	2.2M	2.5V	MQFP-F196	D2 (Note 2)	10	R [100kRAD(Si)]
30	ATC18RHA95_324	2.2M	2.5V	MQFP-F160	D2 (Note 2)	7	R [100kRAD(Si)]
31	ATC18RHA95_324	2.2M	2.5V	LGA-349	(Note 3)	7	R [100kRAD(Si)]
32	ATC18RHA95_404	3.5M	2.5V	MQFP-T352	D2 (Note 2)	27	R [100kRAD(Si)]
33	ATC18RHA95_404	3.5M	2.5V	MQFP-F256	D2 (Note 2)	14	R [100kRAD(Si)]
34	ATC18RHA95_404	3.5M	2.5V	LGA-625	(Note 3)	9	R [100kRAD(Si)]
35	ATC18RHA95_404	3.5M	2.5V	AIN LGA-625	(Note 4)	29	R [100kRAD(Si)]
36	ATC18RHA95_404	3.5M	2.5V	LGA-472	(Note 3)	9	R [100kRAD(Si)]
37	ATC18RHA95_404	3.5M	2.5V	LGA-349	(Note 3)	7	R [100kRAD(Si)]
38	ATC18RHA95_504	5.5M	2.5V	MQFP-T352	D2 (Note 2)	27	R [100kRAD(Si)]
39	ATC18RHA95_504	5.5M	2.5V	MQFP-F256	D2 (Note 2)	14	R [100kRAD(Si)]



Variant Number	Based on Type	Typical Equivalent NAND2 Gate Count	Interface Circuitry Supply Voltage (Note 1)	Case	Terminal Material and Finish	Weight max g	Total Dose Radiation Level Letter (Note 5)
40	ATC18RHA95_504	5.5M	2.5V	LGA-625	(Note 3)	9	R [100kRAD(Si)]
41	ATC18RHA95_504	5.5M	2.5V	AIN LGA-625	(Note 4)	29	R [100kRAD(Si)]
42	ATC18RHA95_504	5.5M	2.5V	LGA-472	(Note 3)	9	R [100kRAD(Si)]
43	ATC18RHA95_504	5.5M	2.5V	LGA-349	(Note 3)	7	R [100kRAD(Si)]
44	ATC18RHA95_544	6.5M	2.5V	LGA-625	(Note 3)	9	R [100kRAD(Si)]
45	ATC18RHA95_544	6.5M	2.5V	AIN LGA-625	(Note 4)	29	R [100kRAD(Si)]
46	ATC18RHA95_544	6.5M	2.5V	LGA-472	(Note 3)	9	R [100kRAD(Si)]
47	ATC18RHA95_324	2.2M	3.3V	MCGA-349	R (Note 2)	9	R [100 kRads(Si)]
48	ATC18RHA95_404	3.5M	3.3V	MCGA-349	R (Note 2)	9	R [100 kRads(Si)]
49	ATC18RHA95_404	3.5M	3.3V	MCGA-472	R (Note 2)	12	R [100 kRads(Si)]
50	ATC18RHA95_504	5.5M	3.3V	MCGA-349	R (Note 2)	9	R [100 kRads(Si)]
51	ATC18RHA95_504	5.5M	3.3V	MCGA-472	R (Note 2)	12	R [100 kRads(Si)]
52	ATC18RHA95_544	6.5M	3.3V	MCGA-472	R (Note 2)	12	R [100 kRads(Si)]
53	ATC18RHA95_324	2.2M	2.5V	MCGA-349	R (Note 2)	9	R [100 kRads(Si)]
54	ATC18RHA95_404	3.5M	2.5V	MCGA-349	R (Note 2)	9	R [100 kRads(Si)]
55	ATC18RHA95_404	3.5M	2.5V	MCGA-472	R (Note 2)	12	R [100 kRads(Si)]
56	ATC18RHA95_504	5.5M	2.5V	MCGA-349	R (Note 2)	9	R [100 kRads(Si)]
57	ATC18RHA95_504	5.5M	2.5V	MCGA-472	R (Note 2)	12	R [100 kRads(Si)]

Variant Number	Based on Type	Typical Equivalent NAND2 Gate Count	Interface Circuitry Supply Voltage (Note 1)	Case	Terminal Material and Finish	Weight max g	Total Dose Radiation Level Letter (Note 5)
58	ATC18RHA95_544	6.5M	2.5V	MCGA-472	R (Note 2)	12	R [100 kRads(Si)]

**NOTES:**

1. The component is specified for operation at a nominal interface circuitry single supply voltage  $V_{CC} = 3.3V$  or  $2.5V$  (See Room Temperature Electrical Measurements).
2. The terminal material and finish shall be in accordance with the requirements of ESCC Basic Specification No. 23500.
3. The terminal material shall be tungsten and the finish shall be  $0.03\mu m$  to  $0.1\mu m$  gold plating over  $3.2\mu m$  minimum nickel underplating.
4. The terminal material shall be tungsten and the finish shall be  $2.5\mu m$  minimum gold plating over  $3.2\mu m$  minimum nickel underplating.
5. The total dose radiation level letter shall be as defined in ESCC Basic Specification No. 22900. If an alternative radiation test level is specified in the Purchase Order the letter shall be changed accordingly.

1.4.3 Manufacturer Specific ASIC Identification

An ASIC Sheet shall be produced by the Manufacturer, after negotiation with the Orderer, that, as a minimum, specifies all the requirements unique to the specific ASIC design that are identified herein as being specified in the ASIC Sheet. The ASIC Sheet shall be held under configuration control by the Manufacturer. For identification and traceability purposes the Manufacturer shall allocate a unique Manufacturer Specific ASIC Identification to the ASIC Sheet and the specific ASIC design as specified in The ESCC Component Number herein.

1.5 MAXIMUM RATINGS

The maximum ratings shall not be exceeded at any time during use or storage.

Maximum ratings shall only be exceeded during testing to the extent specified in this specification and when stipulated in Test Methods and Procedures of the ESCC Generic Specification.

Characteristics	Symbols	Maximum Ratings	Units	Remarks
Supply Voltage	$V_{DD}$ $V_{CC}$	-0.3 to 2 -0.3 to 4	V	Note 1, 2 Note 2, 3
Input Voltage	$V_{IN}$	-0.3 to 4	V	Note 2, 3
Input Current	$I_{IN}$	$\pm 60$ $\pm 10$	mA	Power Input Pins Signal Input Pins
Device Power Dissipation (Continuous)	$P_D$	See ASIC Sheet	W	
Supply Current	$I_{DDop}$	See ASIC Sheet	mA	
Minimum Guaranteed Operating Temperature Range	$T_{op}$	-55 to +125	$^{\circ}C$	$T_{amb}$
Storage Temperature Range	$T_{stg}$	-65 to +150	$^{\circ}C$	
Junction Temperature	$T_j$	+175	$^{\circ}C$	
Thermal Resistance Junction to Case	$R_{th(j-c)}$	See ASIC Sheet	$^{\circ}C/W$	
Soldering Temperature	$T_{sol}$		$^{\circ}C$	
MQFP case		+300		Note 4
MCGA/LGA case		+220		Note 5

**NOTES:**

1. Applicable to the core circuitry.
2. With reference to  $V_{SS} = 0V$ .
3. Applicable to the interface circuitry.
4. For Variants with a Multilayer Quad Flat Package case (MQFP-F160, MQFP-F196, MQFP-F256 & MQFP-T352), duration 10 seconds maximum at a distance of not less than 1.6mm from the device body and the same terminal shall not be resoldered until 3 minutes have elapsed.
5. For Variants with a Land Grid Array case or a Multilayer Column Grid Array case (LGA-349, LGA-472, LGA-625, AIN LGA-625, MCGA-349 & MCGA-472), during reflow.

1.6 **HANDLING PRECAUTIONS**

These devices are susceptible to damage by electrostatic discharge. Therefore, suitable precautions shall be employed for protection during all phases of manufacture, testing, packaging, shipment and any handling.

These components are categorised as Class 2 per ESCC Basic Specification No. 23800 with a Minimum Critical Path Failure Voltage of 2000 Volts.

1.7 PHYSICAL DIMENSIONS AND TERMINAL IDENTIFICATION

1.7.1 Multilayer Quad Flat Package (MQFP-F160) - 160 Flat Leads

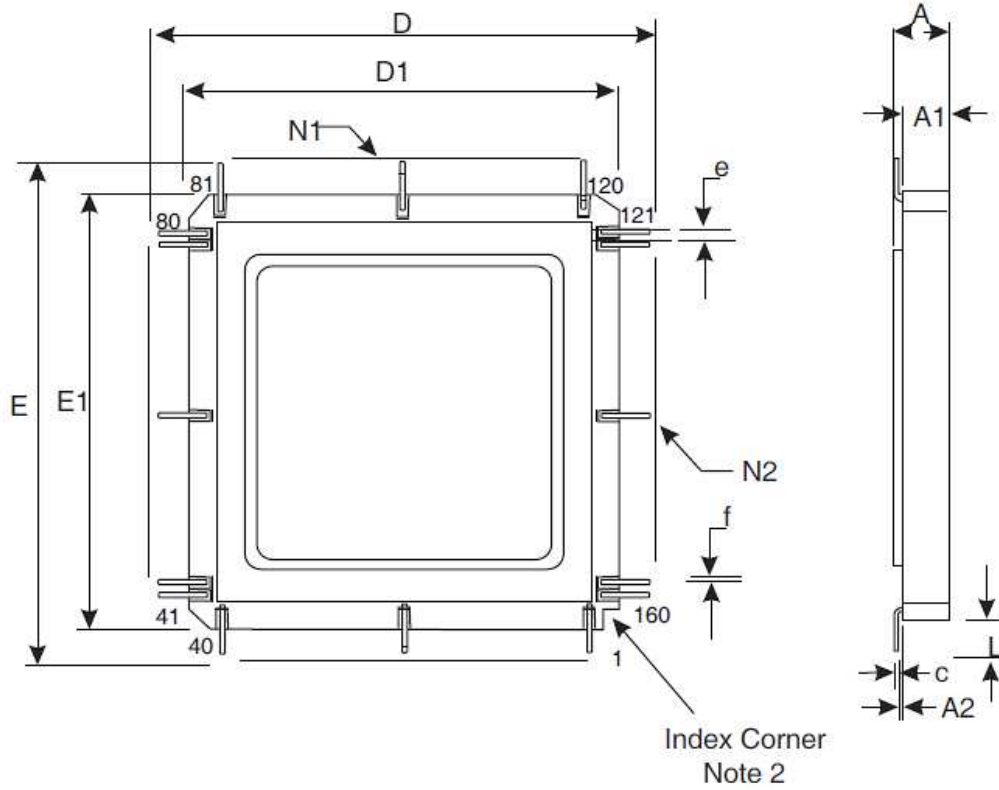

Symbols	Dimensions mm		Notes
	Min	Max	
A	1.96	2.66	
A1	1.7	2.1	
A2	0.1	0.3	
c	0.1	0.2	1
D/E	37.9	39.3	
D1/E1	26.9	27.5	
e	0.650 BSC		1
f	0.25	0.35	1
L	5.5	5.9	1
N1/N2	40		Each side

**NOTES:**

1. Applies to all leads.
2. Terminal identification is specified by reference to the index corner as shown.

1.7.2 Multilayer Quad Flat Package (MQFP-F196) - 196 Flat Leads

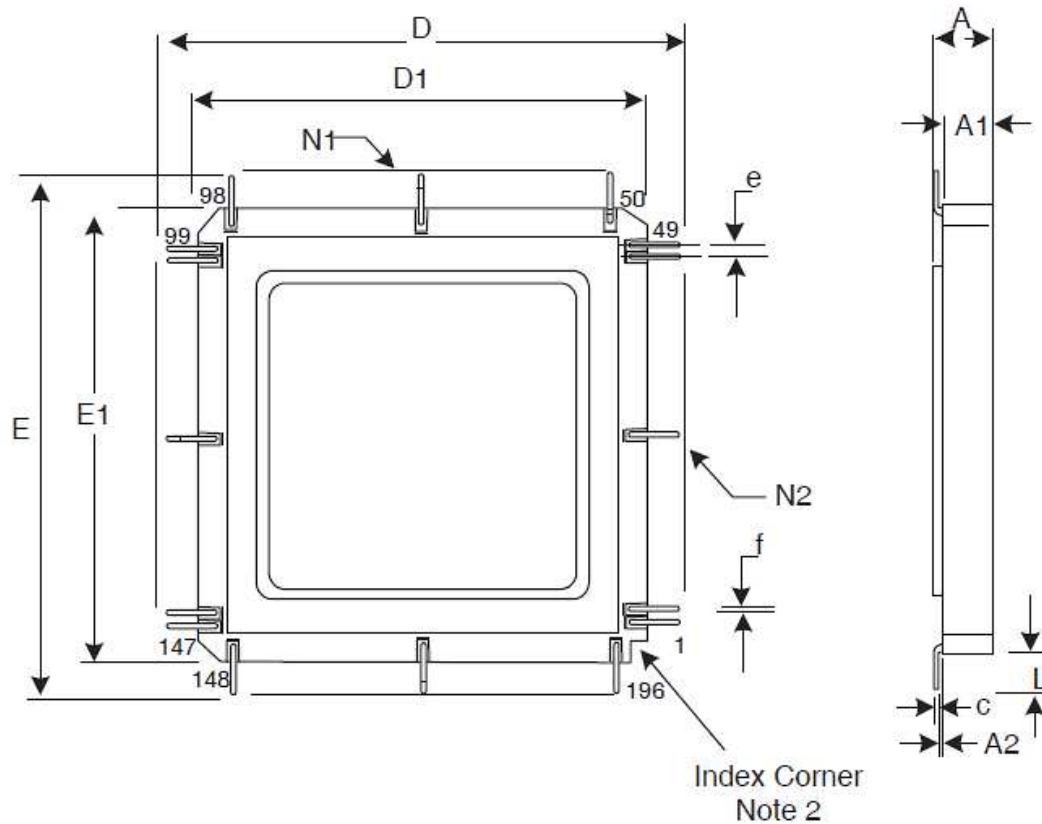

Symbols	Dimensions mm		Notes
	Min	Max	
A	2.13	2.65	
A1	1.83	2.24	
A2	0.202	0.204	
c	0.102	0.203	1
D/E	46.73	47.94	
D1/E1	34.03	34.54	
e	0.635 BSC		1
f	0.15	0.25	1
L	6.35	6.7	1
N1/N2	49		Each side

**NOTES:**

1. Applies to all leads.
2. Terminal identification is specified by reference to the index corner as shown.

1.7.3 Multilayer Quad Flat Package (MQFP-F256) - 256 Flat Leads

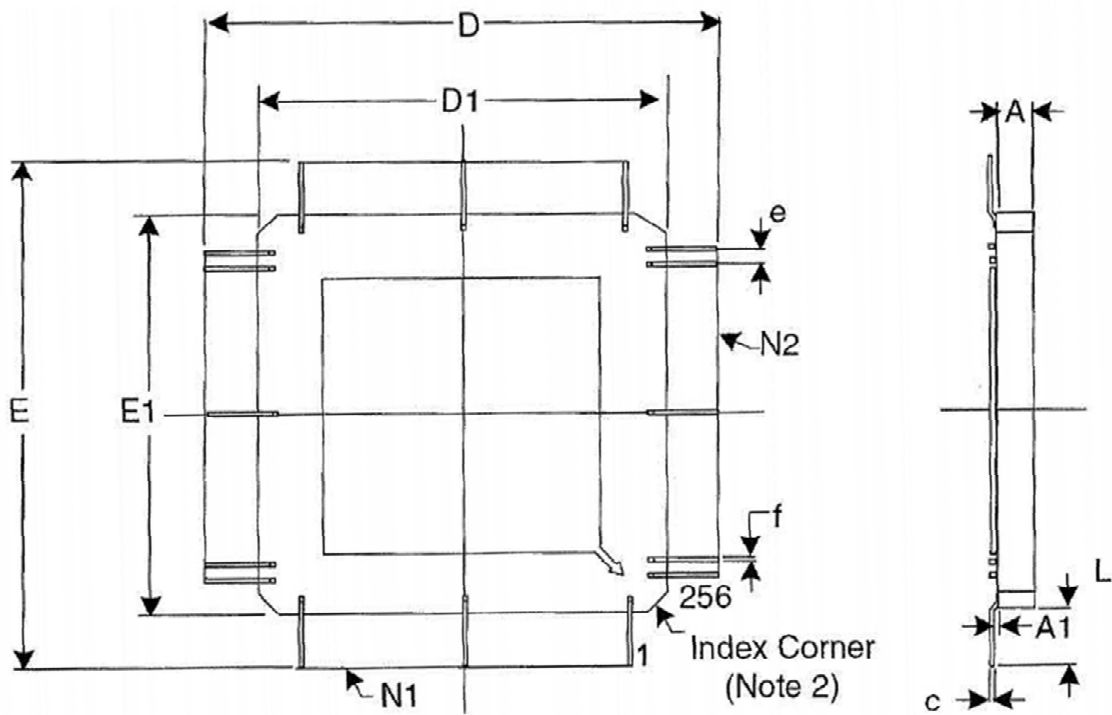

Symbols	Dimensions mm		Notes
	Min	Max	
A	2.06	2.56	
A1	0.05	0.36	
c	0.1	0.2	1
D/E	53.23	55.74	
D1/E1	36.83	37.34	
e	0.508 BSC		1
f	0.15	0.25	1
L	8.2	9.2	1
N1/N2	31.9	32.11	3

**NOTES:**

1. Applies to all leads.
2. Terminal identification is specified by reference to the index corner as shown.
3. Each side (64 leads per side); this dimension is derived from 63 x dimension e.

1.7.4 Multilayer Quad Flat Package (MQFP-T352) - 352 Tied Leads

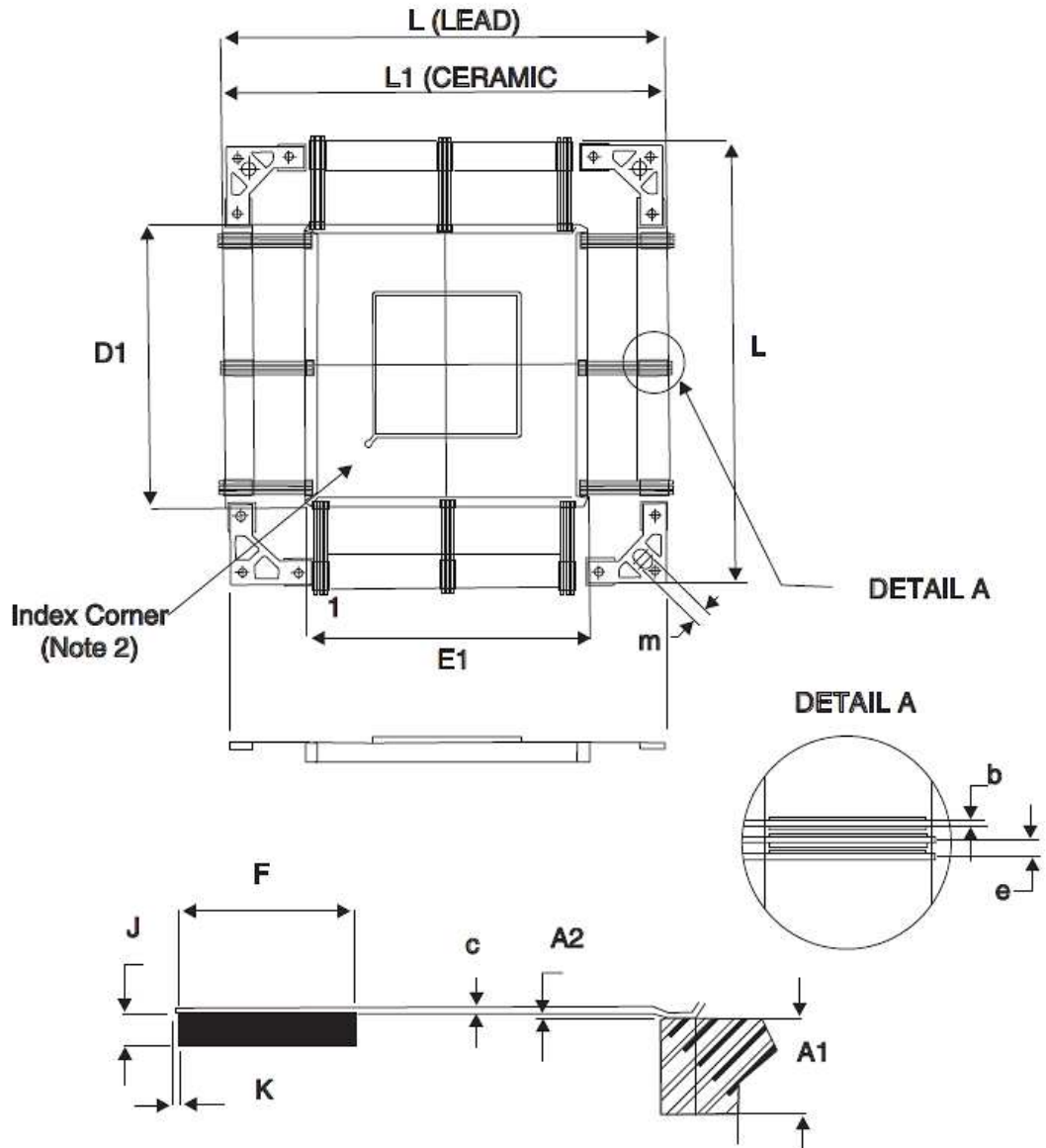

Symbols	Dimensions mm		Notes
	Min	Max	
A1	2.35	3.15	
A2	0.05	0.35	
b	0.19	0.25	1
c	0.11	0.2	1
D1/E1	47.52	48.48	
e	0.50 BSC		1
F	4.5	5.5	

Symbols	Dimensions mm		Notes
	Min	Max	
G	2.5	2.6	
J	0.75	1.05	
K	-	0.5	1
L	74.85	76.4	
L1	74.6	75.4	
m	2.5	2.65	
N1/N2	88		Each side

**NOTES:**

1. Applies to all leads.
2. Terminal identification is specified by reference to the index corner as shown.



1.7.5 Land Grid Array (LGA-349) - 349 Pads

BOTTOM VIEW

TOP VIEW

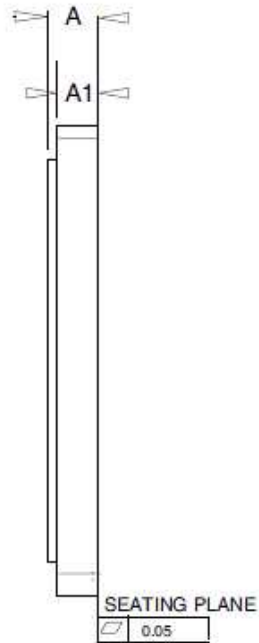
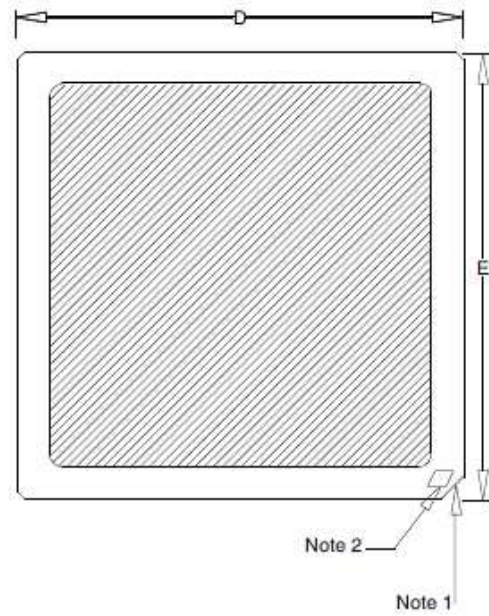
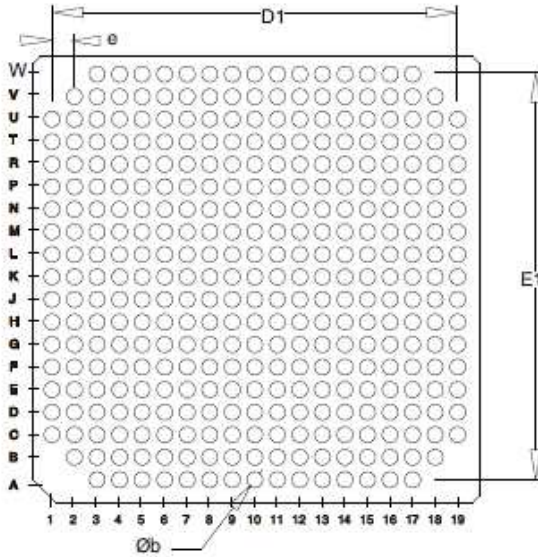

Symbols	Dimensions mm		Notes
	Min	Max	
A	-	3.24	
A1	2.27	2.77	
Øb	0.81	0.91	3
D/E	24.85	25.15	

Symbols	Dimensions mm		Notes
	Min	Max	
D1/E1	22.86 BSC		
e	1.27 BSC		3

**NOTES:**

1. Index corner. Terminal identification is specified by reference to the index corner as shown.
2. A terminal identification mark shall be located at the index corner as shown.
3. Applies to all pads.

1.7.6 Land Grid Array (LGA-472) - 472 Pads

**BOTTOM VIEW**

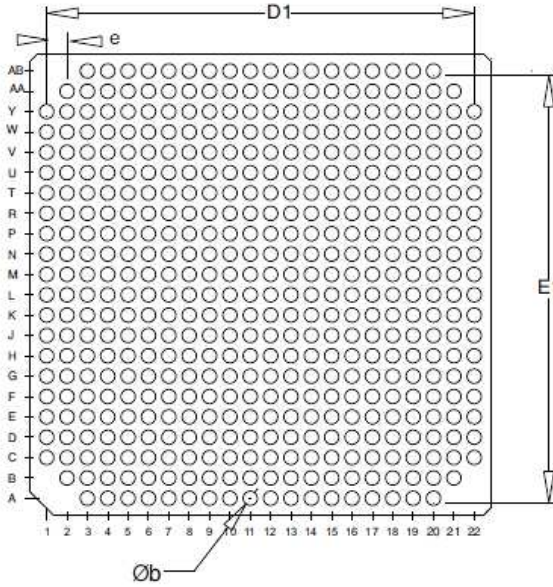

**TOP VIEW**

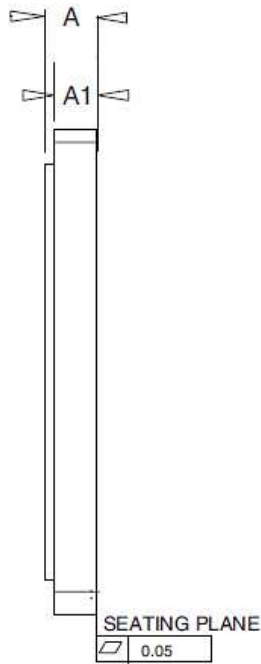
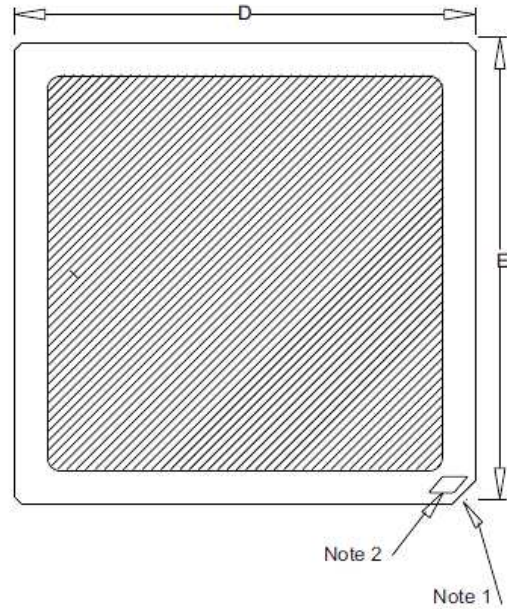

Symbols	Dimensions mm		Notes
	Min	Max	
A	-	3.24	
A1	2.27	2.77	
Øb	0.81	0.91	3
D/E	28.85	29.15	

Symbols	Dimensions mm		Notes
	Min	Max	
D1/E1	26.67 BSC		
e	1.27 BSC		3

**NOTES:**

1. Index corner. Terminal identification is specified by reference to the index corner as shown.
2. A terminal identification mark shall be located at the index corner as shown.
3. Applies to all pads.

1.7.7 Land Grid Array (LGA-625) - 625 Pads

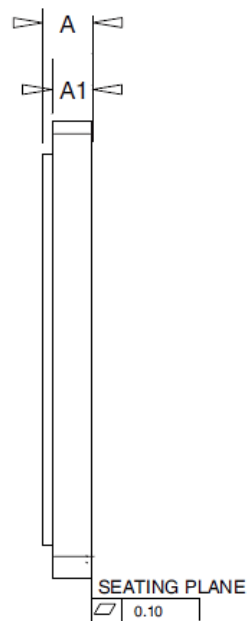
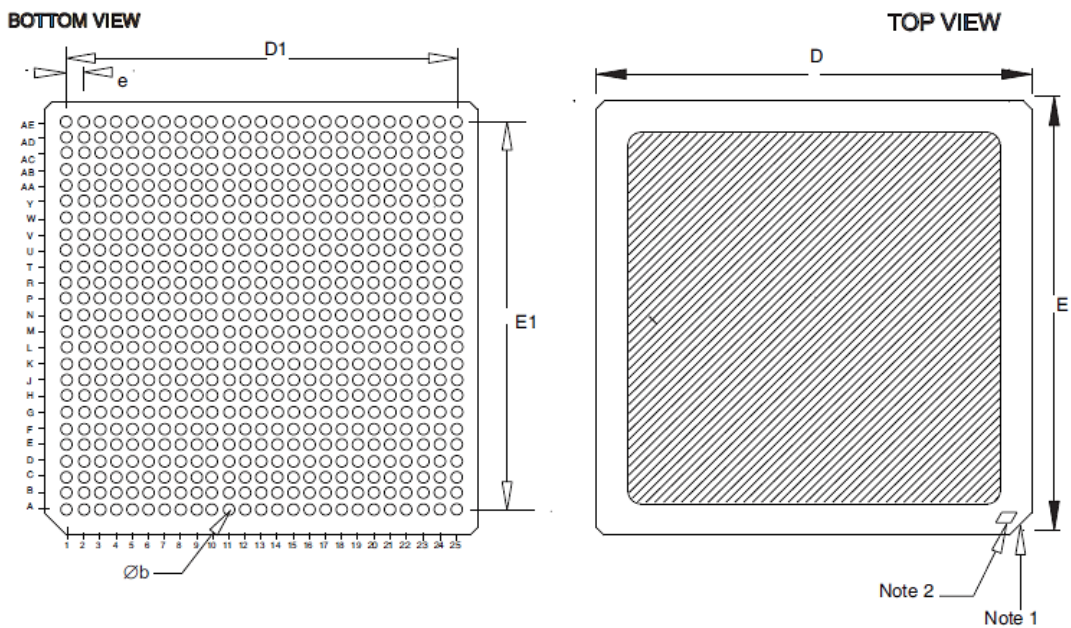

Symbols	Dimensions mm		Notes
	Min	Max	
A	-	3.24	
A1	2.27	2.77	
Øb	0.63	0.73	3
D/E	28.85	29.15	
D1/E1	24.00 BSC		
e	1.00 BSC		3

**NOTES:**

1. Index corner. Terminal identification is specified by reference to the index corner as shown.
2. A terminal identification mark shall be located at the index corner as shown.
3. Applies to all pads.

1.7.8 Land Grid Array (AIN LGA-625) - 625 Pads

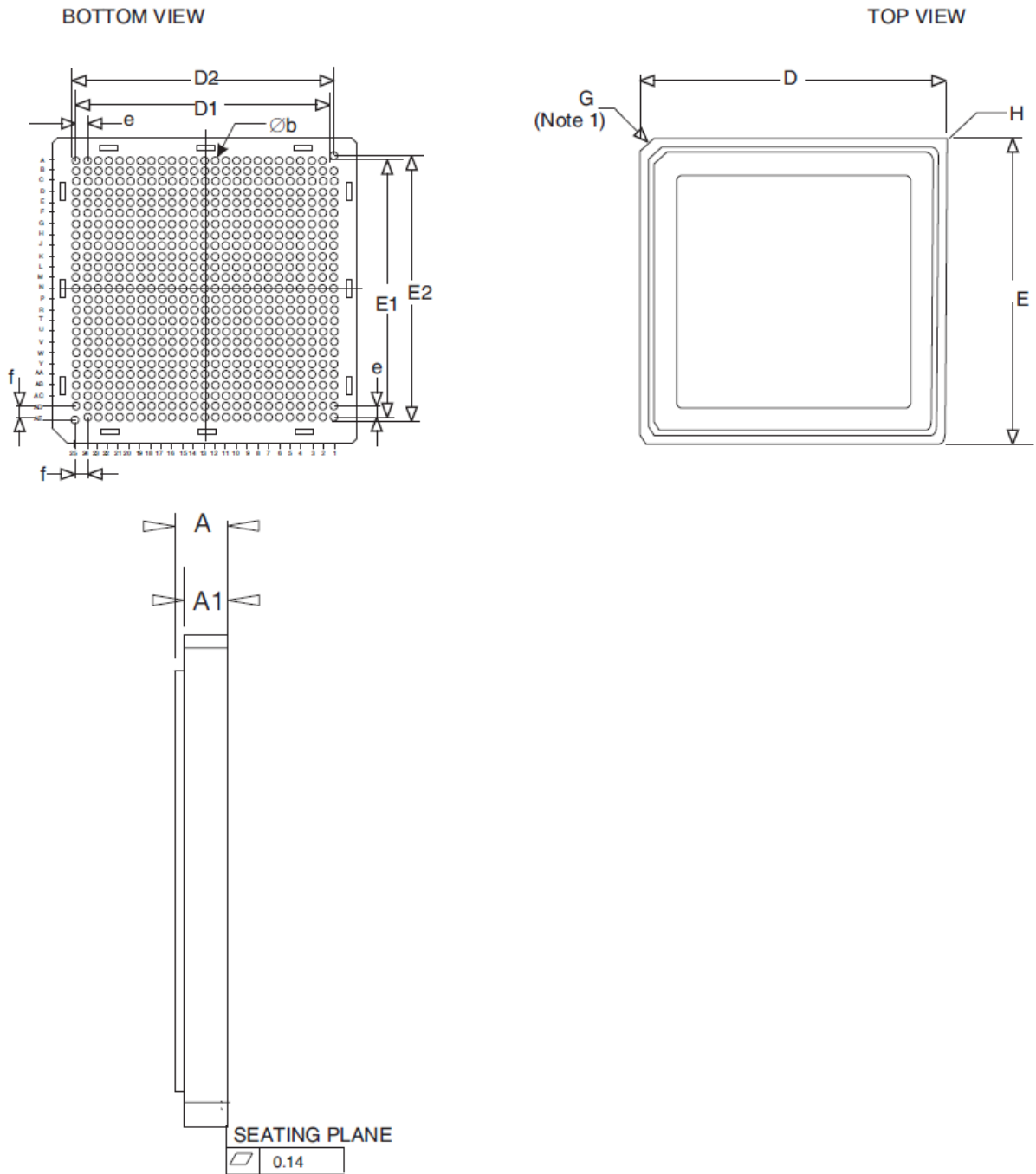

Symbols	Dimensions mm		Notes
	Min	Max	
A	-	7.05	
A1	5.4	6.6	
$\varnothing b$	0.8	0.9	2
D/E	28.85	29.15	

Symbols	Dimensions mm		Notes
	Min	Max	
D1/E1	30.48 BSC		
D2/E2	31.00 BSC		3
e	1.27 BSC		4
f	1.53 BSC		3
G	1.5 x 45° chamfer		1
H	0.5 x 45° chamfer		5

**NOTES:**

1. Index corner. Terminal identification is specified by reference to the index corner as shown.
2. Applies to all pads.
3. Applies to pads A1 and AE25 only.
4. Applies to all pads except A1 and AE25.
5. 3 non-index corners.

1.7.9 Multilayer Column Grid Array (MCGA-349) - 349 Columns

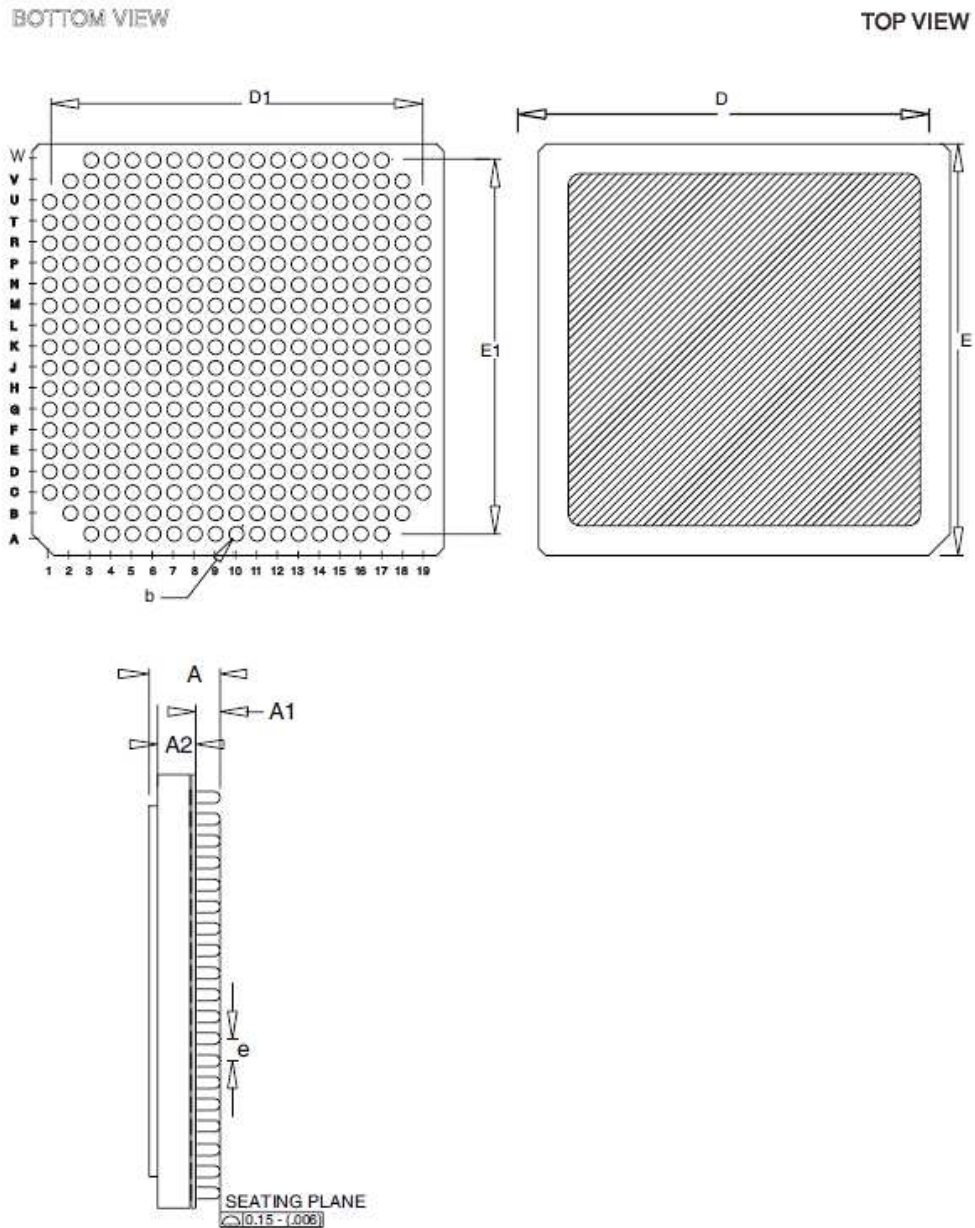

Symbols	Dimensions mm		Notes
	Min	Max	
A	4.3	5.9	
A1	1.4	1.85	
A2	2.4	3.45	
b	0.79	0.99	1
D/E	24.8	25.2	
D1/E1	22.86 BSC		



Symbols	Dimensions mm		Notes
	Min	Max	
e	1.27 BSC		1

**NOTES:**

1. Applies to all columns.
2. Terminal identification is specified by reference to the index corner as shown.

1.7.10 Multilayer Column Grid Array (MCGA-472) - 472 Columns

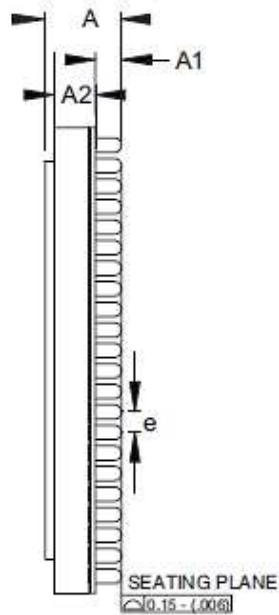
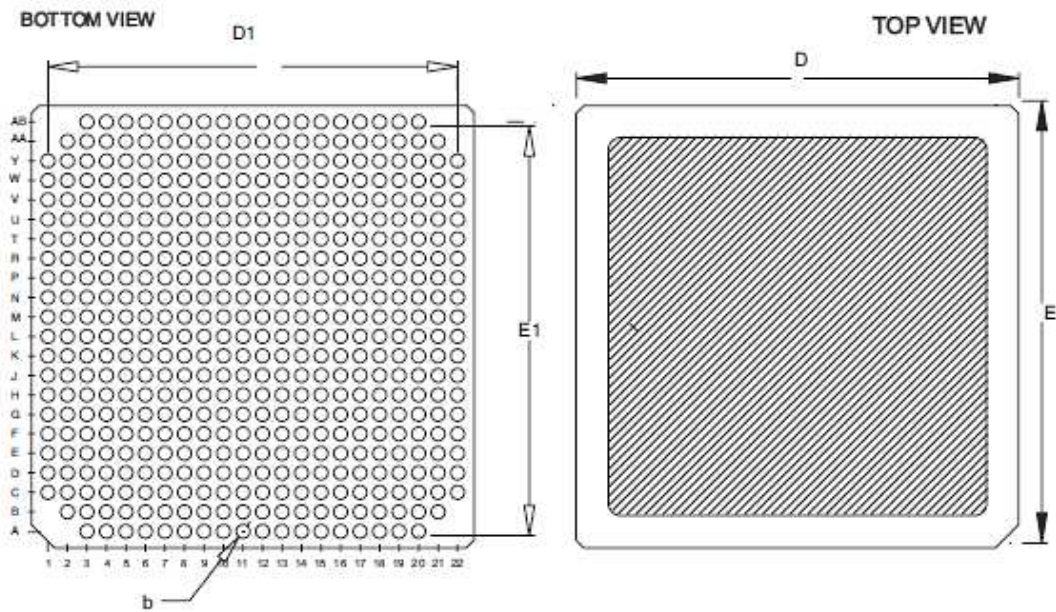

Symbols	Dimensions mm		Notes
	Min	Max	
A	4.3	5.9	
A1	1.4	1.85	
A2	2.6	3.45	
b	0.79	0.99	1
D/E	28.77	29.23	
D1/E1	26.67 BSC		
e	1.27 BSC		1

**NOTES:**

1. Applies to all columns.
2. Terminal identification is specified by reference to the index corner as shown.

1.8 FUNCTIONAL DIAGRAM

See ASIC Sheet.

**NOTES:**

1. For all packages the lid is internally connected to the ground terminal as specified in the ASIC Sheet.

1.9 PIN ASSIGNMENT

See ASIC Sheet.

1.10 INSTRUCTION SET AND TIMING DIAGRAMS

See ASIC Sheet.

**2 REQUIREMENTS**

2.1 GENERAL

The complete requirements for procurement of the components specified herein are as stated in this specification and the ESCC Generic Specification. Permitted deviations from the Generic Specification, applicable to this specification only, are listed below.

Permitted deviations from the Generic Specification and this Detail Specification, formally agreed with specific Manufacturers on the basis that the alternative requirements are equivalent to the ESCC requirement and do not affect the component's reliability, are listed in the appendices attached to this specification.

2.1.1 Deviations from the Generic Specification

2.1.1.1 *Deviations from Screening Tests*

High Temperature Reverse Bias Burn-in shall not be performed.

2.2 MARKING

The marking shall be in accordance with the requirements of ESCC Basic Specification No. 21700 and as follows.

As a minimum the information to be marked on the component shall be:

- (a) The ESCC qualified components symbol (for ESCC qualified components only).
- (b) The ESCC Component Number.
- (c) Traceability information.

The complete marking shall be as specified in the ASIC Sheet.

2.3 ELECTRICAL MEASUREMENTS AT ROOM, HIGH AND LOW TEMPERATURES

Electrical measurements shall be performed at room, high and low temperatures. Consolidated notes are given after the tables.

2.3.1 Room Temperature Electrical Measurements

The measurements shall be performed at  $T_{amb} = +22 \pm 3 \text{ }^\circ\text{C}$ .

2.3.1.1 Room Temperature Electrical Measurements for Components Specified at Supply Voltage  $V_{CC} = 3.3V$  (Variants 01 to 23 and 47 to 52)

Characteristics	Symbols	MIL-STD-883 Test Method	Test Conditions Note 1 $1.65V \leq V_{DD} \leq 1.95V$ $3V \leq V_{CC} \leq 3.6V$	Limits		Units
				Min	Max	
Functional Test 1	-	3014	See ASIC Sheet $V_{CC} = 3V$	-	-	-
Functional Test 2	-	3014	See ASIC Sheet $V_{CC} = 3.3V$	-	-	-
Functional Test 3	-	3014	See ASIC Sheet $V_{CC} = 3.6V$	-	-	-
Supply Current, Stand-by	$I_{CCSB}$	3005	See ASIC Sheet			mA
Supply Current, Operating	$I_{CCOP}$	3005	See ASIC Sheet			mA
Low Level Input Current	$I_{IL}$	3009	$V_{IN} = V_{SS}$ , CMOS Buffers	-1	1	$\mu\text{A}$
Low Level Input Current with Pull-up	$I_{ILPU}$	3009	$V_{IN} = V_{SS}$ , CMOS Buffers	-400	-	$\mu\text{A}$
Low Level Input Current with Pull-down	$I_{ILPD}$	3009	$V_{IN} = V_{SS}$ , CMOS Buffers	-5	5	$\mu\text{A}$
High Level Input Current	$I_{IH}$	3010	$V_{IN} = V_{CC}$ , CMOS Buffers	-1	1	$\mu\text{A}$

Characteristics	Symbols	MIL-STD-883 Test Method	Test Conditions Note 1 $1.65V \leq V_{DD} \leq 1.95V$ $3V \leq V_{CC} \leq 3.6V$	Limits		Units
				Min	Max	
High Level Input Current with Pull-up	$I_{IHPU}$	3010	$V_{IN} = V_{CC}$ , CMOS Buffers	-5	5	$\mu A$
High Level Input Current with Pull-down	$I_{IHPD}$	3010	$V_{IN} = V_{CC}$ , CMOS Buffers	-	600	$\mu A$
Low Level Input Voltage	$V_{IL}$	-	$V_{CC} = 3V$ , CMOS Buffers PCI Buffers	- -	0.8 $0.3 * V_{CC}$	V
High Level Input Voltage	$V_{IH}$	-	$V_{CC} = 3.6V$ , CMOS Buffers PCI Buffers	2 $0.5 * V_{CC}$	- -	V
Low Level Output Voltage	$V_{OL}$	3007	$V_{CC} = 3V$ , $I_{OL} = 2, 4, 8, 12, 16mA$	-	0.4	V
High Level Output Voltage	$V_{OH}$	3006	$V_{CC} = 3V$ , $I_{OH} = -2, -4, -6, -8,$ $-10mA$	$V_{CC}-0.4$	-	V
Output Leakage Current Third State, Low Level Applied	$I_{OZL}$	3020	$V_{OUT} = V_{SS}$	-1	1	$\mu A$
Output Leakage Current Third State, High Level Applied	$I_{OZH}$	3021	$V_{OUT} = 3.6V$	-1	1	$\mu A$
Input Leakage Current, Cold Sparing	$I_{ICS}$	-	$V_{IN} = 0$ to $V_{CC}$	-1	1	$\mu A$
Output Leakage Current, Cold Sparing	$I_{OCS}$	-	$V_{OUT} = 0$ to $V_{CC}$	-1	1	$\mu A$
Output Short Circuit Current, to $V_{CC}$	$I_{OSN}$	-	$n_n = 1$ $V_{OUT} = V_{CC}$ Notes 2, 3	-	23	mA
Output Short Circuit Current, to $V_{SS}$	$I_{OSP}$	-	$n_n = 1$ $V_{OUT} = V_{SS}$ Notes 2, 3	-	23	mA
High Level Output Current	$I_{OH}$	-	PCI Buffers $V_{OH} = V_{CC}-0.4V$	16	-	mA

Characteristics	Symbols	MIL-STD-883 Test Method	Test Conditions Note 1 $1.65V \leq V_{DD} \leq 1.95V$ $3V \leq V_{CC} \leq 3.6V$	Limits		Units
				Min	Max	
Low Level Output Current	$I_{OL}$	-	PCI Buffers $V_{OL} = 0.4V$	16	-	mA
Differential Output Voltage	$V_{OD}$	-	LVDS Transmitter buffers	247	454	mV
Common Mode Output Voltage	$V_{OS}$	-	LVDS Transmitter buffers	1125	1375	mV
Input Capacitance	$C_{IN}$	3012	Note 3	-	7	pF
Timings	-	3003	See ASIC Sheet			ns

2.3.1.2 Room Temperature Electrical Measurements for Components Specified at Supply Voltage  $V_{CC} = 2.5V$  (Variants 24 to 46 and 53 to 58)

Characteristics	Symbols	MIL-STD-883 Test Method	Test Conditions Note 1 $1.65V \leq V_{DD} \leq 1.95V$ $2.3V \leq V_{CC} \leq 2.7V$	Limits		Units
				Min	Max	
Functional Test 1	-	3014	See ASIC Sheet $V_{CC} = 2.3V$	-	-	-
Functional Test 2	-	3014	See ASIC Sheet $V_{CC} = 2.5V$	-	-	-
Functional Test 3	-	3014	See ASIC Sheet $V_{CC} = 2.7V$	-	-	-
Supply Current, Stand-by	$I_{CCSB}$	3005	See ASIC Sheet			mA
Supply Current, Operating	$I_{CCOP}$	3005	See ASIC Sheet			mA
Low Level Input Current	$I_{IL}$	3009	$V_{IN} = V_{SS}$ , CMOS Buffers	-1	1	$\mu A$
Low Level Input Current with Pull-up	$I_{ILPU}$	3009	$V_{IN} = V_{SS}$ , CMOS Buffers	-260	-	$\mu A$
Low Level Input Current with Pull-down	$I_{ILPD}$	3009	$V_{IN} = V_{SS}$ , CMOS Buffers	-5	5	$\mu A$
High Level Input Current	$I_{IH}$	3010	$V_{IN} = V_{CC}$ , CMOS Buffers	-1	1	$\mu A$
High Level Input Current with Pull-up	$I_{IHPU}$	3010	$V_{IN} = V_{CC}$ , CMOS Buffers	-5	5	$\mu A$

Characteristics	Symbols	MIL-STD-883 Test Method	Test Conditions Note 1 $1.65V \leq V_{DD} \leq 1.95V$ $2.3V \leq V_{CC} \leq 2.7V$	Limits		Units
				Min	Max	
High Level Input Current with Pull-down	$I_{IHPD}$	3010	$V_{IN} = V_{CC}$ , CMOS Buffers	-	360	$\mu A$
Low Level Input Voltage	$V_{IL}$	-	$V_{CC} = 2.3V$ , CMOS Buffers	-	0.7	V
High Level Input Voltage	$V_{IH}$	-	$V_{CC} = 2.7V$ , CMOS Buffers	2	-	V
Low Level Output Voltage	$V_{OL}$	3007	$V_{CC} = 2.3V$ , $I_{OL} = 1.5, 3, 6, 9, 12mA$	-	0.4	V
High Level Output Voltage	$V_{OH}$	3006	$V_{CC} = 2.3V$ , $I_{OH} = -1.5, -3, -6, -9,$ $-12mA$	$V_{CC}-0.4$	-	V
Output Leakage Current Third State, Low Level Applied	$I_{OZL}$	3020	$V_{OUT} = V_{SS}$	-1	1	$\mu A$
Output Leakage Current Third State, High Level Applied	$I_{OZH}$	3021	$V_{OUT} = 2.7V$	-1	1	$\mu A$
Input Leakage Current, Cold Sparing	$I_{ICS}$	-	$V_{IN} = 0$ to $V_{CC}$	-1	1	$\mu A$
Output Leakage Current, Cold Sparing	$I_{OCS}$	-	$V_{OUT} = 0$ to $V_{CC}$	-1	1	$\mu A$
Output Short Circuit Current, to $V_{CC}$	$I_{OSN}$	-	$nn = 1$ $V_{OUT} = V_{CC}$ Notes 3, 4	-	14	mA
Output Short Circuit Current, to $V_{SS}$	$I_{OSP}$	-	$nn = 1$ $V_{OUT} = V_{SS}$ Notes 3, 4	-	14	mA
Differential Output Voltage	$V_{OD}$	-	LVDS Transmitter buffers	247	454	mV
Common Mode Output Voltage	$V_{OS}$	-	LVDS Transmitter buffers	1125	1375	mV
Input Capacitance	$C_{IN}$	3012	Note 3	-	7	pF
Timings	-	3003	See ASIC Sheet			ns

2.3.2 Notes to Electrical Measurements Tables

1. Unless otherwise specified: all inputs and outputs shall be tested for each characteristic; Inputs not under test shall be  $V_{IN} = V_{SS}, V_{CC}$  or  $V_{DD}$  and outputs not under test shall be open;  $V_{SS} = 0V$ .
2.  $I_{OS}$  max = 23, 46, 92, 138, 184mA for nn = 1, 2, 4, 6, 8 respectively
3. Tested at initial design and after major process changes, otherwise guaranteed.
4.  $I_{OS}$  max = 14, 28, 56, 84, 112mA for nn = 1, 2, 4, 6, 8 respectively

2.3.3 High and Low Temperatures Electrical Measurements

Unless otherwise specified the measurements shall be performed at  $T_{amb} = +125 (+0 -5) ^\circ C$  and  $T_{amb} = -55 (+5 -0) ^\circ C$ . Unless otherwise specified the characteristics, test methods, conditions and limits shall be the same as specified for Room Temperature Electrical Measurements.

2.4 PARAMETER DRIFT VALUES

Unless otherwise specified, the measurements shall be performed at  $T_{amb} = +22 \pm 3 ^\circ C$ .

The test methods and test conditions shall be as per the corresponding test defined in Room Temperature Electrical Measurements.

The drift values ( $\Delta$ ) shall not be exceeded for each characteristic specified. The corresponding absolute limit values for each characteristic shall not be exceeded.

Characteristics	Symbols	Limits			Units
		Drift Value $\Delta$	Absolute		
			Min	Max	
Supply Current, Stand-by	$I_{DDSB}$	See ASIC Sheet			mA
Low Level Input Current	$I_{IL}$	$\pm 0.1$	-	-1	$\mu A$
High Level Input Current	$I_{IH}$	$\pm 0.1$	-	1	$\mu A$
Output Leakage Current Third State, Low Level Applied	$I_{OZL}$	$\pm 0.1$	-	-1	$\mu A$
Output Leakage Current Third State, High Level Applied	$I_{OZH}$	$\pm 0.1$	-	1	$\mu A$
Low Level Output Voltage	$V_{OL}$	$\pm 100$	-	400	mV
High Level Output Voltage	$V_{OH}$	$\pm 0.1$	$V_{CC}-0.4$	-	V

**NOTES:**

1. Unless otherwise specified all inputs and outputs shall be tested for each characteristic.

2.5 INTERMEDIATE AND END-POINT ELECTRICAL MEASUREMENTS

Unless otherwise specified, the measurements shall be performed at  $T_{amb} = +22 \pm 3 ^\circ C$ . Unless otherwise specified the characteristics, test methods, conditions and limits shall be the same as specified for Room Temperature Electrical Measurements.

## 2.6 POWER BURN-IN CONDITIONS

See ASIC Sheet.

## 2.7 OPERATING LIFE CONDITIONS

Unless otherwise specified the conditions shall be as specified for Power Burn-in.

## 2.8 TOTAL DOSE RADIATION TESTING

### 2.8.1 Bias Conditions and Total Dose Level for Total Dose Radiation Testing

Continuous bias shall be applied during irradiation testing as specified in the ASIC Sheet.

The total dose level applied shall be as specified in the component type variant information herein, in the ASIC Sheet or in the Purchase Order.

### 2.8.2 Electrical Measurements for Total Dose Radiation Testing

Prior to irradiation testing the devices shall have successfully met Room Temperature Electrical Measurements specified herein.

Unless otherwise stated the measurements shall be performed at  $T_{amb} = +22 \pm 3 \text{ }^{\circ}\text{C}$ .

The test methods and test conditions shall be as per the corresponding test defined in Room Temperature Electrical Measurements.

The parameters to be measured during and on completion of irradiation testing are specified in the ASIC Sheet.