



**OPTICAL FIBRE CABLE ASSEMBLIES  
WITH SINGLE FIBRE FERRULES**

**BASED ON TYPE MINI-AVIM**

**ESCC Detail Specification No. 3420/001**

Issue 1	June 2017
---------	-----------



**LEGAL DISCLAIMER AND COPYRIGHT**

European Space Agency, Copyright © 2017, All rights reserved.

The European Space Agency disclaims any liability or responsibility, to any person or entity, with respect to any loss or damage caused, or alleged to be caused, directly or indirectly by the use and application of this ESCC publication.

This publication, without the prior permission of the European Space Agency and provided that it is not used for a commercial purpose, may be:

- copied in whole, in any medium, without alteration or modification.
- copied in part, in any medium, provided that the ESCC document identification, comprising the ESCC symbol, document number and document issue, is removed.

**DOCUMENTATION CHANGE NOTICE**

(Refer to <https://escies.org> for ESCC DCR content)

DCR No.	CHANGE DESCRIPTION

**TABLE OF CONTENTS**

1	GENERAL	6
1.1	SCOPE	6
1.2	APPLICABLE DOCUMENTS	6
1.3	TERMS, DEFINITIONS, ABBREVIATIONS, SYMBOLS AND UNITS	6
1.4	THE ESCC COMPONENT NUMBER AND COMPONENT TYPE VARIANTS	6
1.4.1	The ESCC Component Number	6
1.4.1.1	Characteristics Codes	7
1.4.2	Component Type Variants and Range of Components	9
1.5	MAXIMUM RATINGS	10
1.6	HANDLING PRECAUTIONS	10
1.7	PHYSICAL DIMENSIONS	11
1.7.1	Optical Fibre Cable Assembly (All Configurations) – Variant 01	11
1.7.2	Mating Adapter (Mini-AVIM / Mini-AVIM) – Variant 02	12
1.7.3	Mating Adapter (Mini-AVIM / AVIM) – Variant 03	13
1.7.4	Mini-AVIM Interface Module with Square Flange without Stopper (for PC 0°) – Variant 04	14
1.7.5	Mini-AVIM Interface Module with Square Flange with Stopper (for APC 8°) – Variant 05	14
1.7.6	Optical Connector: Mini-AVIM / Mini-AVIM Cable (Variant 01)	15
1.7.7	Optical Connector: Others (Variant 01)	16
1.7.7.1	AVIM	16
1.7.7.2	DMI	17
1.7.7.3	Ferrule 2.5 x 10.5mm and Ferrule 2.5 x 17.5mm	17
1.7.8	Optical Interface and Polishing (Variant 01)	18
1.7.8.1	Polishing Types: PC 0° and Flat 0°	19
1.7.8.2	Polishing Types: APC 4°, APC 8° and Flat 8°	20
1.7.9	Optical Fibre	21
1.7.9.1	Optical Function Type: SM and PS	21
1.7.9.2	Optical Function Type: PM and PM-PS	22
1.7.10	Cable	23
1.8	MATERIALS AND FINISHES	24
2	REQUIREMENTS	24
2.1	GENERAL	24
2.1.1	Deviations from the Generic Specification	24
2.1.1.1	Deviations from Screening Tests – Chart F3	24
2.2	MARKING	25
2.3	ROOM TEMPERATURE OPTICAL AND GEOMETRICAL MEASUREMENTS	25
2.3.1	Geometrical Measurements	25



2.3.2	Optical Measurements	26
2.4	PARAMETER DRIFT VALUES	28
2.5	INTERMEDIATE AND END-POINT OPTICAL AND GEOMETRICAL MEASUREMENTS	28
<b>APPENDIX A</b>		<b>33</b>

## 1 GENERAL

### 1.1 SCOPE

This specification details the ratings, physical and electrical characteristics and test and inspection data for the component type variants and/or the range of components specified below. It supplements the requirements of, and shall be read in conjunction with, the ESCC Generic Specification listed under Applicable Documents.

### 1.2 APPLICABLE DOCUMENTS

The following documents form part of this specification and shall be read in conjunction with it:

- (a) ESCC Generic Specification No. [3420](#).

### 1.3 TERMS, DEFINITIONS, ABBREVIATIONS, SYMBOLS AND UNITS

For the purpose of this specification, the terms, definitions, abbreviations, symbols and units specified in ESCC Basic Specification No. [21300](#) shall apply.

### 1.4 THE ESCC COMPONENT NUMBER AND COMPONENT TYPE VARIANTS

#### 1.4.1 The ESCC Component Number

The ESCC Component Number shall be constituted as follows:

Example (for Optical Fibre Cable Assemblies: Variant 01):

342000101-01B-M0P-D4PH-6000

- Detail Specification Reference: 3420001
- Component Type Variant Number: 01 (all Optical Fibre Cable Assembly configurations)
- Characteristic Code: Optical Fibre Type (SM.15-P-8/125-UV/UV-400): 01 (as required)
- Characteristic Code: Cable Type (Bare Fibre): B (as required)
- Characteristic Code: Connector A Type (Mini-AVIM): M (as required)
- Characteristic Code: Connector A Polishing (PC 0°): 0 (as required)
- Characteristic Code: Connector A Optical Function (PM): P (as required)
- Characteristic Code: Connector B Type (DMI): D (as required)
- Characteristic Code: Connector B Polishing (APC 4°): 4 (as required)
- Characteristic Code: Connector B Optical Function (PM-PS): PH (as required)
- Characteristic Code: Total Assembly Length (6000mm): 6000 (as required)

Example (for Mating Adapters and Interface Modules: Variants 02 to 05):

342000102

- Detail Specification Reference: 3420001
- Component Type Variant Number: 02 (as required)

1.4.1.1 Characteristics Codes

Characteristics to be codified as part of the ESCC Component Number shall be as follows:

(a) Optical Fibre Type and Optical Function

The optical fibre type and related optical function available for each connector, at side A and/or side B (as applicable), for of the optical fibre cable assembly shall be expressed by means of the following codes:

Optical Fibre Type	Optical Fibre Type Code	Optical Function	Optical Function Code
SM.15-P-8/125-UV/UV-400	01	PM (Single Mode Polarization Maintaining)	P
		PM-PS (Single Mode Polarization Maintaining, Power Solution Collimated)	PH
HI-1060-H	02	SM (Single Mode)	S
		PS (Single Mode, Power Solution Collimated)	H
SMF-28e+	03	SM (Single Mode)	S
		PS (Single Mode, Power Solution Collimated)	H

(b) Cable Type

The cable type of the optical fibre cable assembly shall be expressed by means of the following codes:

Cable Type	Code	Remarks
Not Applicable (Bare Fibre Only)	B	
PEEK Loose Tube	P	
Elastomeric Loose Tube	H	
Short Section of PEEK Loose Tube over Bare Fibre	S	Pigtails only

(c) Optical Connector A Type

The connector type at side A of the optical fibre cable assembly shall be expressed by means of the following codes:

Connector A Type	Code	Remarks
Mini-AVIM	M	For optical fibre cable assemblies without cable (single bare fibre only)
Mini-AVIM Cable	Mc	For optical fibre cable assemblies with cable (with single fibre).

- (d) **Optical Connector B Type**  
 The connector type at side B of the optical fibre cable assembly shall be expressed by means of the following codes:

Connector B Type	Code	Remarks
AVIM	A	For single fibre
DMI	D	For single fibre
Ferrule 2.5 x 10.5mm	F	For single fibre
Ferrule 2.5 x 17.5mm	L	For single fibre
No Connector	X	Pigtail

- (e) **Polishing Type (Connectors A and/or B)**  
 The polishing type applicable to the ferrule and fibre end-face in each connector, at side A and/or side B (as applicable), of the optical fibre cable assembly shall be expressed by means of the following codes:

Polishing Type	Code	Remarks
PC 0° (Physical Contact)	0	Used with optical function: SM, PM, PS, PM-PS
APC 8° (Angled Physical Contact)	8	Used with optical function: SM, PM
APC 4° (Angled Physical Contact)	4	Used with optical function: PS, PM-PS
Flat 0° (Flat free space)	0F	Used with optical function: SM, PM, PS, PM-PS
Flat 8° (Angled Flat free space)	8F	Used with optical function: SM, PM, PS, PM-PS
Not Applicable	X	Code to be used for the connector at side B when the Connector B type: No Connector (Code X; Pigtail) has been specified

- (f) **Optical Fibre Cable Assembly Length**  
 The total length, L, of the optical fibre cable assembly shall be expressed by means of the following codes:

Total Optical Fibre Cable Assembly Length L (mm)	Code
XXX (200 to 999)	0XXX
XXXX (1000 to 6000)	XXXX



1.4.2 Component Type Variants and Range of Components

The component type variants and range of components applicable to this specification are as follows:

Variant Number	Component Type	Physical Configuration	Optical Connector/Fibre/Cable and Function	Weight Max (g)
01	Mini-AVIM Optical Fibre Cable Assembly (All configurations)	See Para. 1.7.1	See Note 1	See Note 2
02	Mating Adapter with Square Flange (Mini-AVIM / Mini-AVIM)	See Para. 1.7.2	N/A	2.6
03	Hybrid Mating Adapter (Mini-AVIM / AVIM)	See Para. 1.7.3	N/A	1.7
04	Mini-AVIM Interface Module with Square Flange without Stopper (for PC 0°)	See Para. 1.7.4	N/A	1.4
05	Mini-AVIM Interface Module with Square Flange with Stopper (for APC 8°)	See Para. 1.7.5	N/A	1.4

**NOTES:**

1. The available configurations for optical fibre cable assemblies including details of the optical connectors, fibre, cable and function shall be as indicated in Para. 1.4.1.1.
2. The total maximum weight of an optical fibre cable assembly is calculated from the individual maximum weights of the various piece parts, as applicable, as follows:

Piece Part Category	Type	Weight Max
Optical Connector	Mini-AVIM	1.2g
	Mini-AVIM Cable	2.8g
	AVIM	6.2g
	DMI	0.4g
	Ferrule 2.5 x 10.5mm	0.25g
	Ferrule 2.5 x 17.5mm	0.3g
Optical Fibre	All Types	0.2g/m
Cable	PEEK Loose Tube	0.7g/m
	Elastomeric Loose Tube	0.6g/m

1.5 MAXIMUM RATINGS

The maximum ratings shall not be exceeded at any time during use or storage.

Maximum ratings shall only be exceeded during testing to the extent specified in this specification and when stipulated in Test Methods and Procedures of the ESCC Generic Specification.

Characteristics	Symbols	Maximum Ratings	Units	Remarks
Operating Temperature Range	T <sub>op</sub>	-55 to +85	°C	T <sub>amb</sub>
Storage Temperature Range	T <sub>stg</sub>	-55 to +85	°C	
Operating Wavelength Range <ul style="list-style-type: none"> <li>• SM.15-P-8/125-UV/UV-400</li> <li>• HI-1060-H</li> <li>• SMF-28e+</li> </ul>	λ	1540 to 1625 980 to 1150 1300 to 1625	nm	For all assemblies using the specified optical fibre type. Note 1
Coupling Nut Torque	T <sub>q</sub>	0.3	N.cm	

**NOTES:**

1. Nominal operating wavelength shall be as follows:
  - Optical fibre type: SM.15-P-8/125-UV/UV-400: 1550nm
  - Optical fibre type: HI-1060-H: 1060nm
  - Optical fibre type: SMF-28e+: 1550nm

1.6 HANDLING PRECAUTIONS

These devices are susceptible to degradation due to contamination. Dust covers provided shall be used to protect the ferrule end-face when the connectors are in an unmated condition. Direct contact with the ferrule end-face during handling should be prevented.

In order to ensure correct function, each mating shall occur after a visual inspection and, if necessary, cleaning of the ferrule end-faces on both sides of a connection and the mating adapter.

In the event that contamination of the ferrule end-face has occurred, it can be cleaned using a suitable method which should be verified by a visual examination at x200 magnification.

1.7 PHYSICAL DIMENSIONS

1.7.1 Optical Fibre Cable Assembly (All Configurations) – Variant 01

**EXAMPLE: PATCHCORD (NOTE 1)**

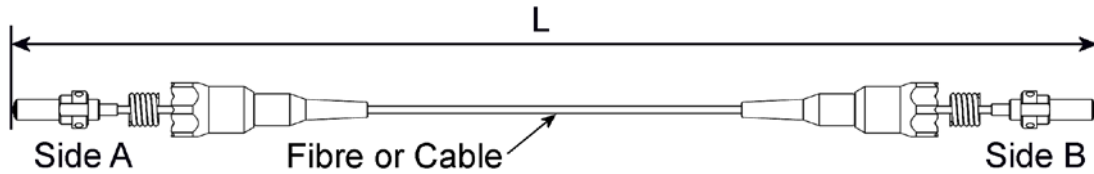

**EXAMPLE: HYBRID PATCHCORD (NOTE 2)**

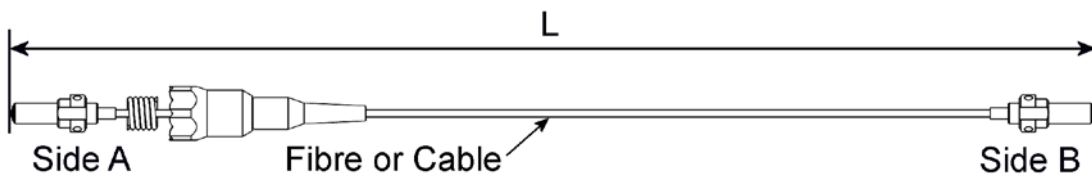

**EXAMPLE: PIGTAIL (NOTE 3)**

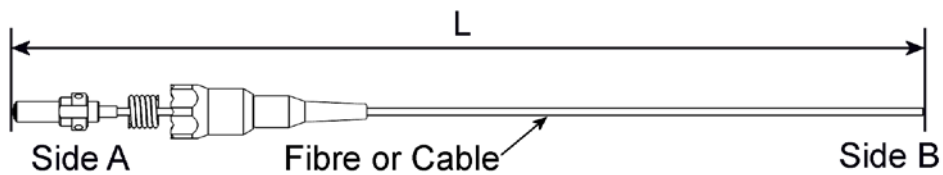

**EXAMPLE: PIGTAIL (NOTE 3)**

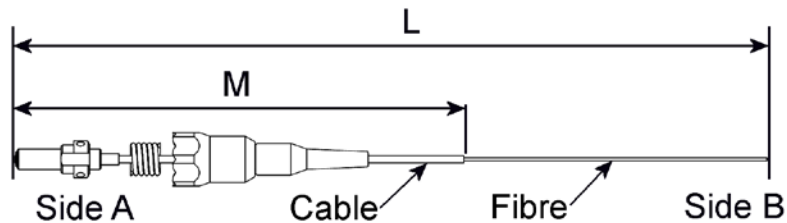

Symbols	Dimensions (mm)		Tolerance (mm)	Remarks
	Min	Max		
L	200	499	±50	As required
	500	999	±100	
	1000	6000	±150	
M	60		±5	Only for Pigtails with cable type: Short Section of PEEK Loose Tube over Bare Fibre

**NOTES:**

1. Patchcords have the same connector type on side A and B; see Para. 1.7.6.
2. Hybrid patchcords have a different connector type on side B to that on side A; see Para. 1.7.6 for side A and Para. 1.7.7 for side B.
3. Pigtails only have a connector on side A; see Para. 1.7.6.

1.7.2 Mating Adapter (Mini-AVIM / Mini-AVIM) – Variant 02

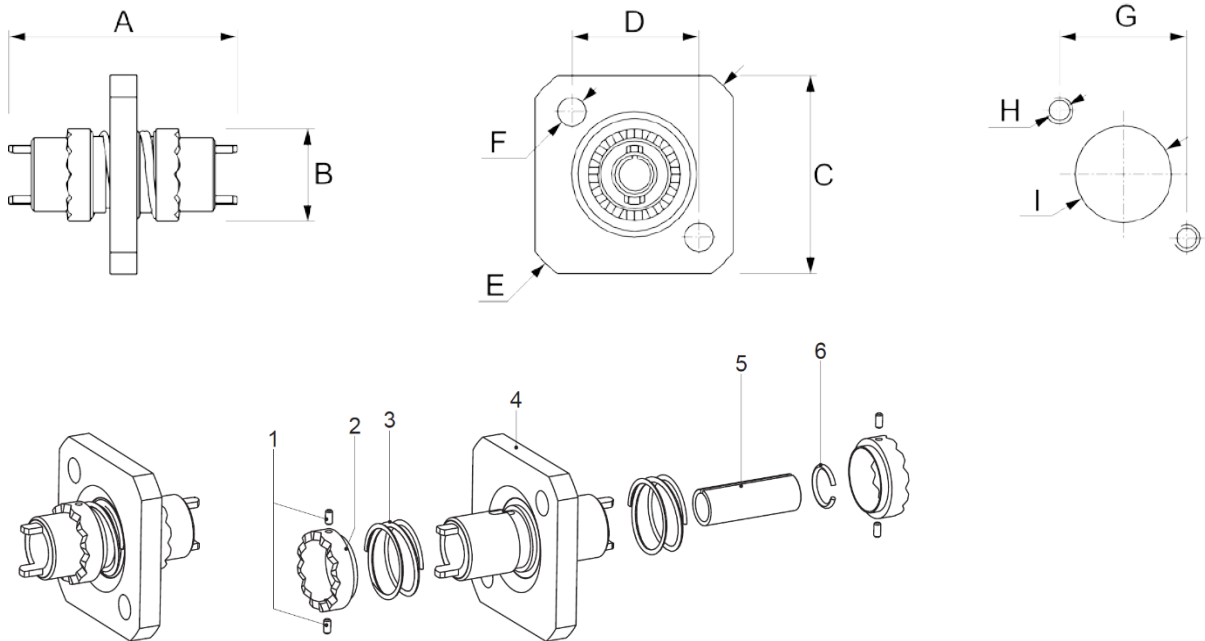

Symbols	Dimensions (mm)		Remarks
	Min	Max	
A	17.1	17.3	
ØB	6.8	7.2	
C	14.9	15.1	square
D	9.4	9.6	square
ØE	18.9	19.1	
ØF	2.2	2.4	
G	9.3	9.7	Cut out
ØH	M2.2		Cut out
ØI	7.3	7.7	Cut out

**NOTES:**

1. Exploded part item view key:
  - 1: Pin (x4)
  - 2: Anti-rotation ring
  - 3: Anti-rotation spring (x2)
  - 4: Main body & flange
  - 5: Split sleeve
  - 6: Locking washer

1.7.3 Mating Adapter (Mini-AVIM / AVIM) – Variant 03

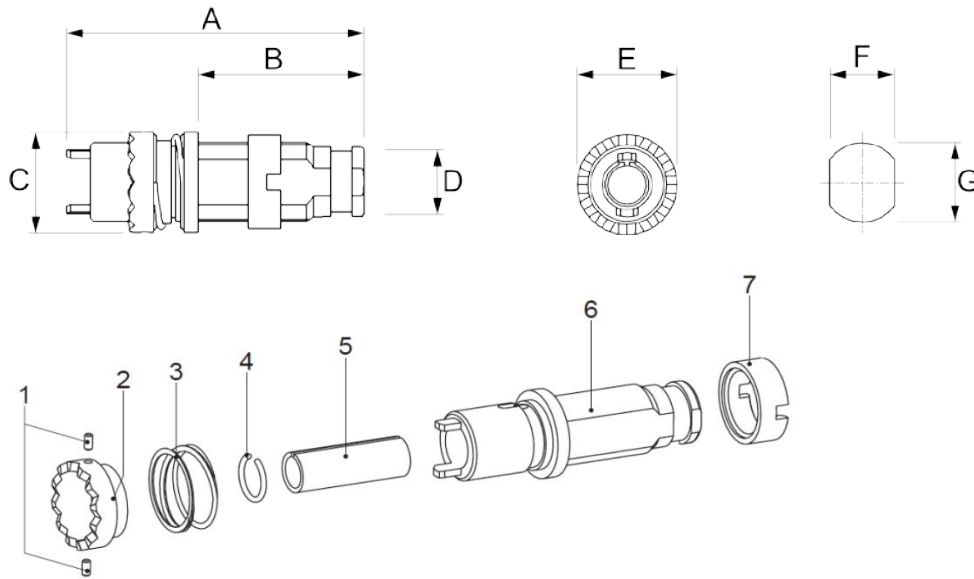

Symbols	Dimensions (mm)		Remarks
	Min	Max	
A	20.7	20.9	
B	11.4	11.6	
ØC	6.9	7.1	
D	4.2	4.3	
ØE	6.9	7.1	
F	4.3	4.7	Cut out
ØG	5.7	5.9	Cut out

**NOTES:**

1. Exploded part item view key:
  - 1: Pin (x2)
  - 2: Anti-rotation ring
  - 3: Anti-rotation spring
  - 4: Locking washer
  - 5: Split sleeve
  - 6: Main body
  - 7: Locking ring

1.7.4 Mini-AVIM Interface Module with Square Flange without Stopper (for PC 0°) – Variant 04

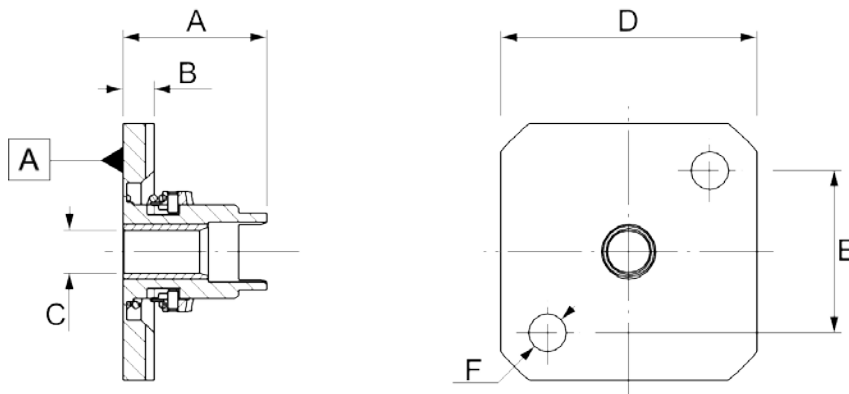

Symbols	Dimensions (mm)		Remarks
	Min	Max	
A	8.3	8.5	
B	1.75	1.85	
ØC	6.8	7.2	
D	14.9	15.1	square
E	9.4	9.6	square
ØF	2.2	2.22	

1.7.5 Mini-AVIM Interface Module with Square Flange with Stopper (for APC 8°) – Variant 05

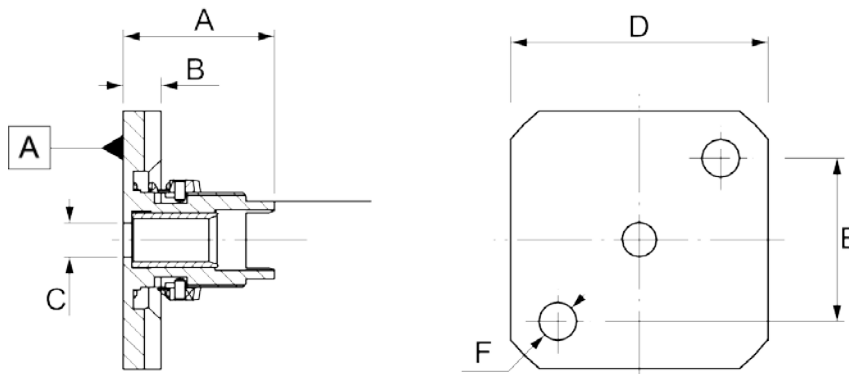

Symbols	Dimensions (mm)		Remarks
	Min	Max	
A	8.7	8.9	
B	2.1	2.3	
ØC	1.95	2.05	
D	14.9	15.1	Square
E	9.4	9.6	Square
ØF	2.2	2.22	

1.7.6 Optical Connector: Mini-AVIM / Mini-AVIM Cable (Variant 01)

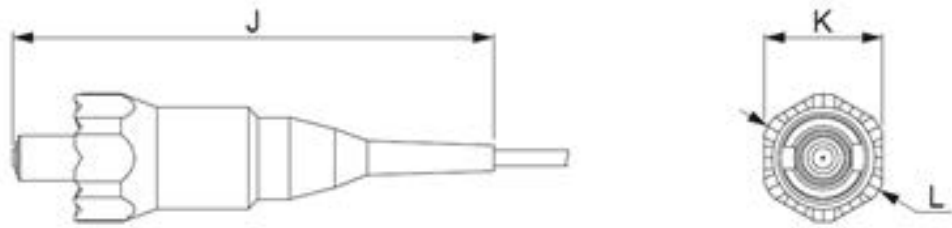

Mini-AVIM Exploded View

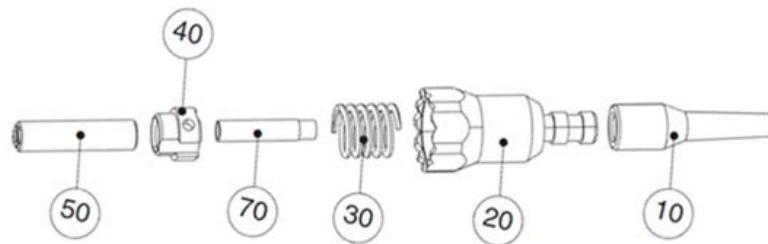

Mini-AVIM Cable Exploded View

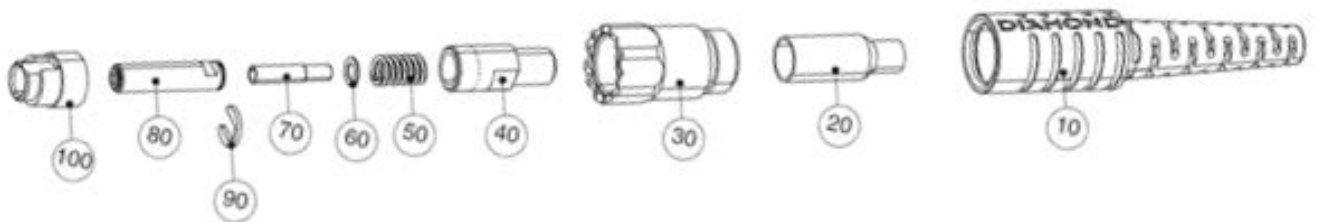

Ferrule Assembly Details

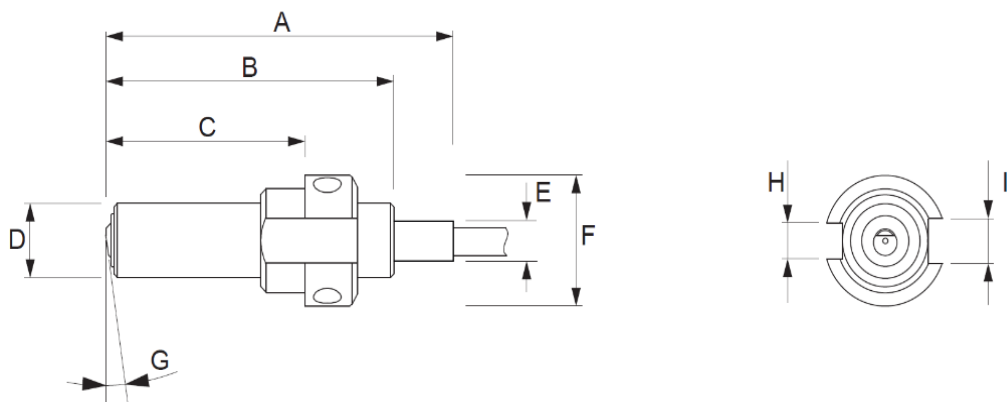

Symbols	Dimensions (mm)		Remarks
	Min	Max	
A	12.1	12.5	
B	10.45	10.6	
C	7.15	7.30	
ØD	2.5		Optical interface; see Para. 1.7.8
ØE	1.4	1.6	
ØF	4.35	4.45	
G	0°, 4° or 8°		Optical interface; see Para. 1.7.8
H	1.21	1.22	Mechanical key A
I	1.51	1.52	Mechanical key B
J	26	28	For Mini-AVIM
K	6.45	6.5	Across flats
L	6.95	7.05	

**NOTES:**

1. Exploded part item view key: Mini-AVIM:

- 10: Anti-flexion boot
- 20: Outside shell
- 30: Spring
- 40: Interface ring
- 50: Ferrule
- 70: Ferrule tube

Exploded part item view key: Mini-AVIM Cable:

- 10: Anti-flexion boot
- 20: Crimp sleeve
- 30: Outside shell
- 40: Body
- 50: Ferrule spring
- 60: Anti-rotation washer
- 70: Ferrule tube
- 80: Ferrule
- 90: Clip
- 100: Anti-rotation nose

1.7.7 Optical Connector: Others (Variant 01)

1.7.7.1 *AVIM*

See ESCC Detail Specification No. [3420/002](#).



1.7.7.2 *DMI*

See Para. 1.7.6, using same part items for mini-AVIM: 40 Interface ring, 50 ferrule and 70 ferrule tube (Dimensions A to I inclusive).

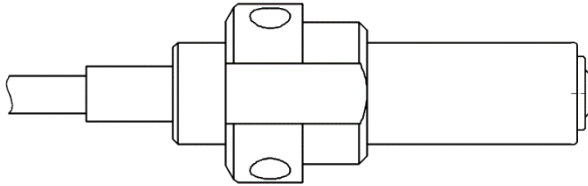

1.7.7.3 *Ferrule 2.5 x 10.5mm and Ferrule 2.5 x 17.5mm*

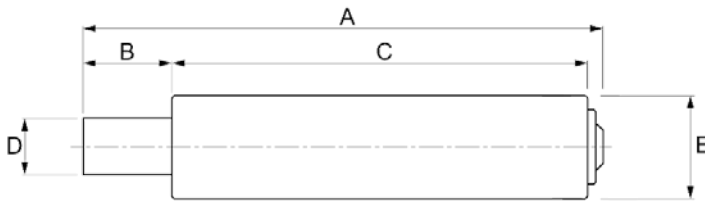

Symbols	Dimensions (mm)		Remarks
	Min	Max	
A	12.1	12.5	For Ferrule 2.5mm x 10.5mm
	17.1	17.5	For Ferrule 2.5mm x 17.5mm
B	1.5	2.1	
C	10.45	10.6	For Ferrule 2.5mm x 10.5mm
	17.45	17.6	For Ferrule 2.5mm x 17.5mm
ØD	1.4	1.6	
ØE	2.5		Optical interface; see Para. 1.7.8

1.7.8 Optical Interface and Polishing (Variant 01)

Ferrule End-Face

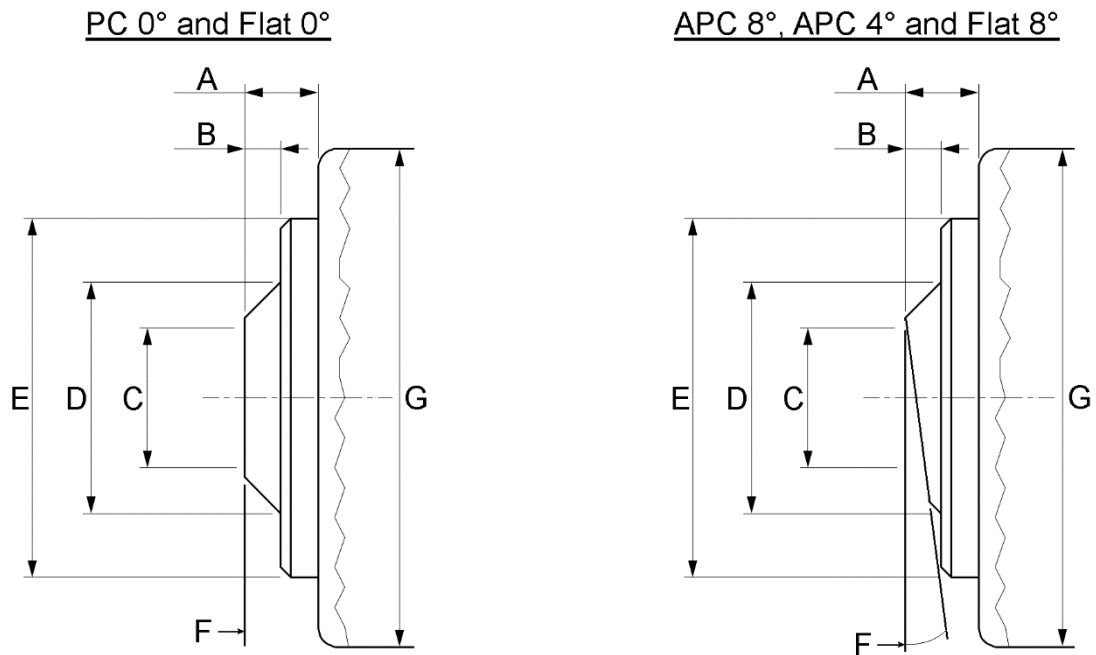

Symbols	Dimensions (mm)		Remarks
	Min	Max	
A	0.37	0.42	
B	0.18	0.23	
ØC	0.66	0.72	
ØD	1.155	1.165	
ØE	1.75	1.85	
F	0°		See Para. 1.7.8.1
	4° or 8°		See Para. 1.7.8.2
ØG	2.499	2.4992	Ferrule outer diameter. For optical function: SM, PM, PS, PM-PS

1.7.8.1 Polishing Types: PC 0° and Flat 0°

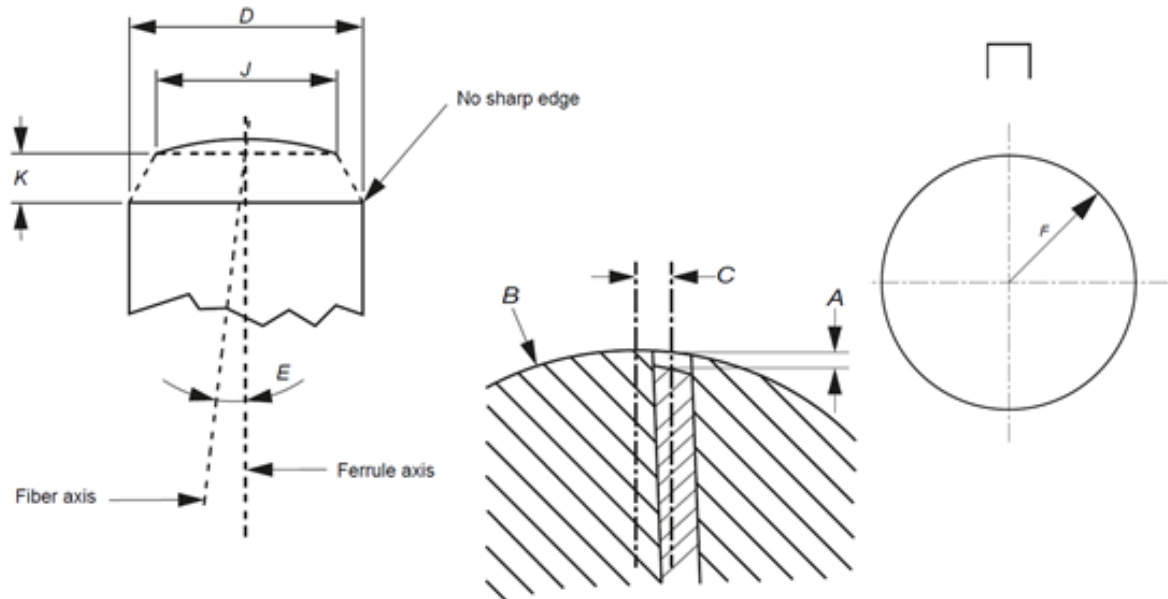

Symbols	Dimensions (1)		Remarks
	Min	Max	
A	-0.0002	+0.0002	Optical fibre undercut/protrusion
B	7	20	Ferrule radius for polishing type: PC 0°
	40	-	Ferrule radius for polishing type: Flat 0°
C	-	0.0625	Apex offset for polishing type: PC 0°
	-	N/A	Apex offset for polishing type: Flat 0°
E	-0.6°	0.6°	Exit angle; only for optical function types: SM, PM
	-0.1°	0.1°	Exit angle; only for optical function types: PS, PM-PS
F	-	0.00025	Eccentricity of fibre core to the centre of the ferrule; only for optical function types: SM, PM
	-	0.000015	Eccentricity of fibre core to the centre of the ferrule; only for optical function types: PS, PM-PS
G	-0.6°	0.6°	Angle of polished surface for polishing: PC 0° and Flat 0°

**NOTES:**

1. mm unless otherwise specified.

1.7.8.2 Polishing Types: APC 4°, APC 8° and Flat 8°

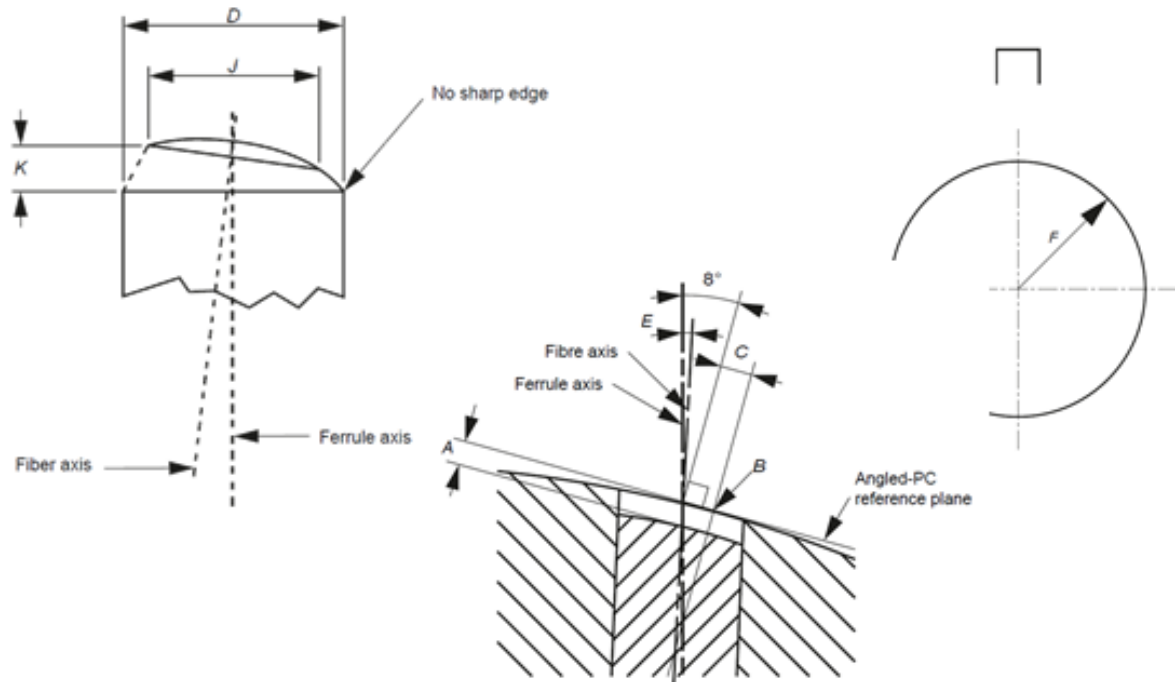

Symbols	Dimensions (1)		Remarks
	Min	Max	
A	-0.0002	+0.0002	Optical fibre undercut/protrusion
B	7	20	Ferrule radius for polishing type: APC 4° and APC 8°
	40	-	Ferrule radius for polishing type: Flat 8°
C	-	0.0625	Apex offset for polishing type: APC 4° and APC 8°
	-	N/A	Apex offset for polishing type: Flat 8°
E	-0.6°	0.6°	Exit angle; only for optical function types: SM, PM
	-0.1°	0.1°	Exit angle; only for optical function types: PS, PM-PS
F	-	0.00025	Eccentricity of fibre core to the centre of the ferrule; only for optical function types: SM, PM
	-	0.000015	Eccentricity of fibre core to the centre of the ferrule; only for optical function types: PS, PM-PS
G	3.4°	4.6°	Angle of polished surface for polishing: APC 4°
	7.4°	8.6°	Angle of polished surface for polishing: APC 8° and Flat 8°

**NOTES:**

1. mm unless otherwise specified.

1.7.9 Optical Fibre

1.7.9.1 Optical Function Type: SM and PS

Single Mode Fibre with Optical Function SM

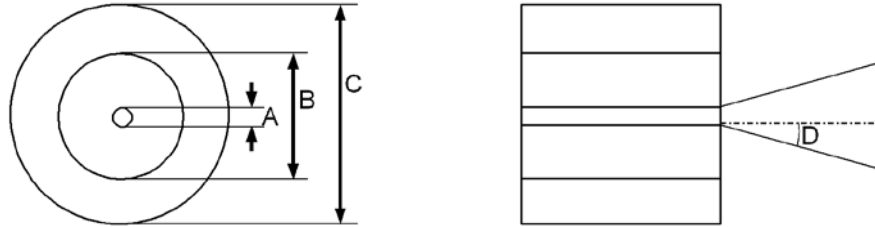

Optical Function PS (Note 2)

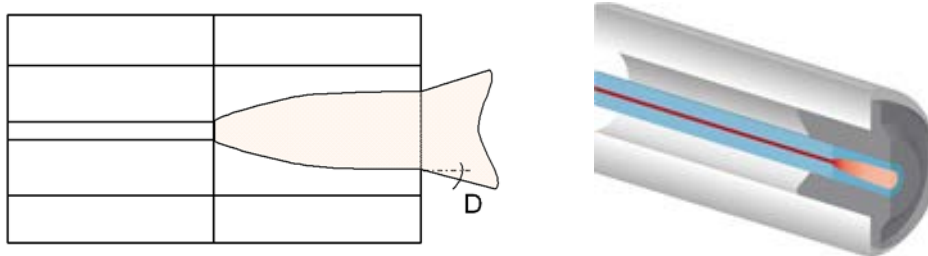

Optical Fibre Type	Symbols	Dimensions (1)		Optical Function	Remarks
		Min	Max		
HI-1060-H	ØA	5.3		SM	Mode Field Diameter
		30	40	PS	Mode Field Diameter
	ØB	120	130	SM	Glass cladding outside diameter
		123	127	PS	Glass cladding outside diameter
	ØC	235	255	SM, PS	Coating outside diameter
	D	0.1	0.14	SM	Numerical Aperture, Note 3
0.03		0.04	PS	Numerical Aperture, Note 3	
SMF-28e+	ØA	8.2		SM	Mode Field Diameter
		30	45	PS	Mode Field Diameter
	ØB	124.3	125.7	SM	Glass cladding outside diameter
		123	127	PS	Glass cladding outside diameter
	ØC	240	250	SM, PS	Coating outside diameter
	D	0.1	0.14	SM	Numerical Aperture, Note 3
0.03		0.04	PS	Numerical Aperture, Note 3	

**NOTES:**

1.  $\mu\text{m}$  unless otherwise specified.
2. Optical function type PS includes a graded index lens spliced at the end of the fibre.
3. Defined at  $1/e^2$  and at the nominal operating wavelength of the optical fibre.

1.7.9.2 Optical Function Type: PM and PM-PS

Polarization Maintaining Panda Optical Fibre with Optical Function PM

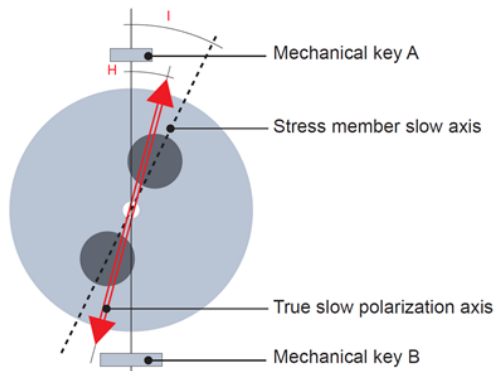
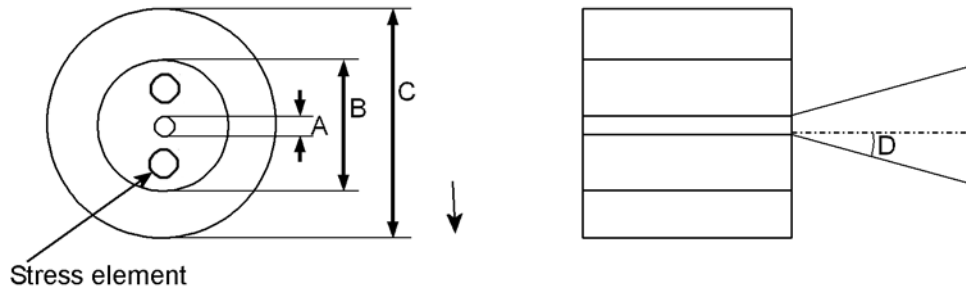

Optical Function PM-PS (Note 2)

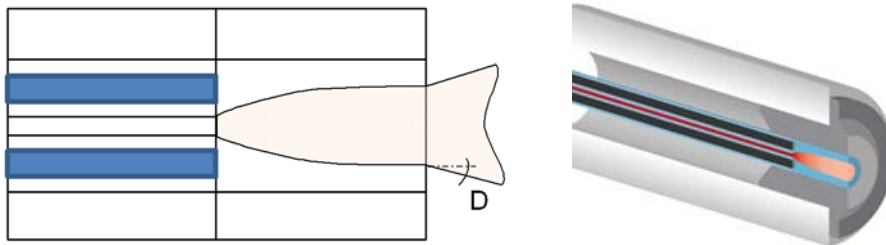

Optical Fibre Type	Symbols	Dimensions (1)		Optical Function	Remarks
		Min	Max		
SM.15-P-8/125-UV/UV-400	ØA	9.5	11.5	PM	Mode Field Diameter
		30	42	PM-PS	Mode Field Diameter
	ØB	122	128	PM	Glass cladding outside diameter
		123	127	PM-PS	Glass cladding outside diameter
	ØC	380	420	PM, PM-PS	Coating outside diameter
	D	0.1	0.14	PM	Numerical Aperture, Note 3
		0.03	0.04	PM-PS	Numerical Aperture, Note 3
	H	-2°	+2°	PM, PM-PS	Orientation angle of the true slow polarization axis of the fibre relative to the connector mechanical keys A and B; see Para. 1.7.6.
I	-2°	+2°	PM	Orientation angle of the optical fibre stress member axis relative to the connector mechanical keys A and B; see Para. 1.7.6. Note 4	

**NOTES:**

1. µm unless otherwise specified.
2. Optical function type PM-PS includes a graded index lens spliced at the end of the fibre.
3. Defined at  $1/e^2$  and at the nominal operating wavelength of the optical fibre.
4. Dimension H is the default requirement. Dimension I only applies when Dimension H cannot be determined.

1.7.10 Cable

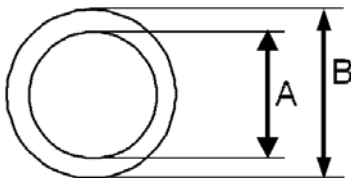

Cable Type	Symbols	Dimensions (mm)	
		Min	Max
PEEK Loose Tube	ØA	0.4	0.5
Elastomeric Loose Tube		0.4	0.6
PEEK Loose Tube	ØB	0.9	1.1
Elastomeric Loose Tube		0.8	1.1

## 1.8 MATERIALS AND FINISHES

Specific materials and finishes shall be as follows:

### (a) Optical fibre:

- SM.15-P-8/125-UV/UV-400:
  - Manufacturer: Fujikura
  - Type: Polarization maintaining (panda)
  - Coating: Acrylate
- HI-1060-H; manufacturer: Corning
  - Manufacturer: Corning
  - Type: Single mode, high index
  - Coating: Acrylate
- SMF-28e+; manufacturer: Corning
  - Manufacturer: Corning
  - Type: Single mode
  - Coating: Acrylate

### (b) Cable:

- PEEK Loose Tube: Material: unreinforced Polyetheretherketone; colour: natural/beige
- Elastomeric Loose Tube: colour: transparent

### (c) Optical Connector Anti-flexion Boot: Material: thermoplastic polyester elastomer; colour:

- Blue for polishing type PC 0°
- Red for polishing type APC 4°
- Green for polishing type APC 8°
- Black for polishing types Flat 0° and Flat 8°

## 2 REQUIREMENTS

### 2.1 GENERAL

The complete requirements for procurement of the components specified herein are as stated in this specification and the ESCC Generic Specification. Permitted deviations from the Generic Specification, applicable to this specification only, are listed below.

Permitted deviations from the Generic Specification and this Detail Specification, formally agreed with specific Manufacturers on the basis that the alternative requirements are equivalent to the ESCC requirement and do not affect the component's reliability, are listed in the appendices attached to this specification.

#### 2.1.1 Deviations from the Generic Specification

##### 2.1.1.1 *Deviations from Screening Tests – Chart F3*

- (a) Para. 8.8, Sinusoidal Vibration: shall not be performed.



2.2 MARKING

The marking shall be in accordance with the requirements of ESCC Basic Specification No. 21700 and as follows.

The information to be marked on the component shall be:

- (a) The ESCC qualified components symbol (for ESCC qualified components only).
- (b) The ESCC Component Number.
- (c) Traceability information.

2.3 ROOM TEMPERATURE OPTICAL AND GEOMETRICAL MEASUREMENTS

The measurements shall be performed at  $T_{amb} = +22 \pm 3^{\circ}C$ .

2.3.1 Geometrical Measurements

Characteristics		Symbols	ESCC No. 3420 Test Method and Conditions	Limits		Units
				Min	Max	
End-face Geometry	Apex Offset	AO	Para. 8.6.1.5 Polishing: <ul style="list-style-type: none"> <li>• PC 0°, APC 4°, APC 8°</li> <li>• Flat 0°, Flat 8°</li> </ul>	- N/A	62.5 N/A	µm
	Radius of Curvature	RC	Para. 8.6.1.5 Polishing: <ul style="list-style-type: none"> <li>• PC 0°, APC 4°, APC 8°</li> <li>• Flat 0°, Flat 8°</li> </ul>	7 40	20 -	mm
	Optical Fibre Protrusion	OFP	Para. 8.6.1.5 Polishing type: all	-200	+200	nm

2.3.2 Optical Measurements

(a) Optical Fibre Cable Assemblies using optical fibre type: SM.15-P-8/125-UV/UV-400:

Characteristics	Symbols	ESCC No. 3420 Test Method and Conditions	Limits		Units
			Min	Max	
Insertion Loss	IL	Para. 8.3.1.1 Test wavelength = 1550nm Optical function/Polishing: <ul style="list-style-type: none"> <li>• PM / PC 0°</li> <li>• PM / APC 8°</li> <li>• PM / Flat 0°</li> <li>• PM / Flat 8°</li> <li>• PM-PS / PC 0°</li> <li>• PM-PS / APC 4°</li> </ul>	-	0.5	dB
Transient Loss Threshold	TL	Para. 8.3.1.2 Test wavelength = 1550nm	0.5	-	dB
Return Loss	RL	Para. 8.3.1.3 Test wavelength = 1550nm Optical function/Polishing: <ul style="list-style-type: none"> <li>• PM / PC 0°</li> <li>• PM / APC 8°</li> <li>• PM / Flat 0°</li> <li>• PM / Flat 8°</li> <li>• PM-PS / PC 0°</li> <li>• PM-PS / APC 4°</li> </ul>	50 70 10 10 35 55	- - - - - -	dB
Polarization Extinction Ratio	PER	Para. 8.3.1.4 Test wavelength = 1550nm Optical function: <ul style="list-style-type: none"> <li>• PM</li> <li>• PM-PS</li> </ul>	21 20	- -	dB
Polarization Angle	PA	Para. 8.3.1.4 Test wavelength = 1550nm	-2	+2	°

(b) Optical Fibre Cable Assemblies using optical fibre type: HI-1060-H:

Characteristics	Symbols	ESCC No. 3420 Test Method and Conditions	Limits		Units
			Min	Max	
Insertion Loss	IL	Para. 8.3.1.1 Test wavelength = 980nm Optical function/Polishing: <ul style="list-style-type: none"> <li>• SM / PC 0°</li> <li>• SM / APC 8°</li> <li>• SM / Flat 0°</li> <li>• SM / Flat 8°</li> <li>• PS / PC 0°</li> <li>• PS / APC 4°</li> </ul>	-	0.5	dB
Transient Loss Threshold	TL	Para. 8.3.1.2 Test wavelength = 980nm	0.5	-	dB
Return Loss	RL	Para. 8.3.1.3 Test wavelength = 980nm Optical function/Polishing: <ul style="list-style-type: none"> <li>• SM / PC 0°</li> <li>• SM / APC 8°</li> <li>• SM / Flat 0°</li> <li>• SM / Flat 8°</li> <li>• PS / PC 0°</li> <li>• PS / APC 4°</li> </ul>	50	-	dB
			60	-	
			10	-	
			10	-	
			35	-	
			60	-	

(c) Optical Fibre Cable Assemblies using optical fibre type: SMF-28e+:

Characteristics	Symbols	ESCC No. 3420 Test Method and Conditions	Limits		Units
			Min	Max	
Insertion Loss	IL	Para. 8.3.1.1 Test wavelength = 1550nm Optical function/Polishing: <ul style="list-style-type: none"> <li>• SM / PC 0°</li> <li>• SM / APC 8°</li> <li>• SM / Flat 0°</li> <li>• SM / Flat 8°</li> <li>• PS / PC 0°</li> <li>• PS / APC 4°</li> </ul>	-	0.5	dB
Transient Loss Threshold	TL	Para. 8.3.1.2 Test wavelength = 1550nm	0.5	-	dB
Return Loss	RL	Para. 8.3.1.3 Test wavelength = 1550nm Optical function/Polishing: <ul style="list-style-type: none"> <li>• SM / PC 0°</li> <li>• SM / APC 8°</li> <li>• SM / Flat 0°</li> <li>• SM / Flat 8°</li> <li>• PS / PC 0°</li> <li>• PS / APC 4°</li> </ul>	50	-	dB
			75	-	
			10	-	
			10	-	
			45	-	
			75	-	

2.4 PARAMETER DRIFT VALUES

Unless otherwise specified, the measurements shall be performed at  $T_{amb} = +22 \pm 3^{\circ}C$ .

The test methods and test conditions shall be as per the corresponding test defined in Para. 2.3, Room Temperature Optical and Geometrical Measurements.

The drift values ( $\Delta$ ) shall not be exceeded for each characteristic where specified. The corresponding absolute limit values for each characteristic shall not be exceeded.

Characteristics	Symbols	Drift Value $\Delta$		Units	
		Drift Value $\Delta$	Absolute		
			Min		Max
Insertion Loss	IL	$\pm 0.4$	As per Para. 2.3		dB
Return Loss	RL	$\pm 0.4$	As per Para. 2.3		dB

2.5 INTERMEDIATE AND END-POINT OPTICAL AND GEOMETRICAL MEASUREMENTS

Unless otherwise specified, the measurements shall be performed at  $T_{amb} = +22 \pm 3^{\circ}C$ .

Unless otherwise specified, test methods and test conditions shall be as per the corresponding test defined in Para. 2.3, Room Temperature Optical and Geometrical Measurements.

The drift values ( $\Delta$ ) shall not be exceeded for each characteristic where specified. The corresponding absolute limit values for each characteristic shall not be exceeded.

Test Reference per ESCC No. 3420	Characteristics	Symbols	Limits		Units
			Min	Max	
Temperature Cycling Initial Measurements	Insertion Loss	IL	As per Para. 2.3		
	Return Loss	RL	As per Para. 2.3		
	Polarization Extinction Ratio	PER	As per Para. 2.3		
	End-face Geometry:		As per Para. 2.3		
	Apex Offset	AO	As per Para. 2.3		
	Radius of Curvature	RC			
	Optical Fibre Protrusion	OFF			
Measurements during testing.	Variation of Insertion Loss	$\Delta IL$	-0.4	+0.4	dB
	Variation of Return Loss	$\Delta RL$	-0.4	+0.4	dB
Final Measurements	Insertion Loss	IL	As per Para. 2.3		
	Return Loss	RL	As per Para. 2.3		
	Polarization Extinction Ratio	PER	As per Para. 2.3		
	End-face Geometry:		As per Para. 2.3		
	Apex Offset	AO	As per Para. 2.3		
	Radius of Curvature	RC	As per Para. 2.3		
	Optical Fibre Protrusion	OFF	As per Para. 2.3		

Test Reference per ESCC No. 3420	Characteristics	Symbols	Limits		Units
			Min	Max	
Humidity Cycling Initial Measurements  Measurements during testing.  Final Measurements	Insertion Loss	IL	As per Para. 2.3		dB
	Return Loss	RL	As per Para. 2.3		
	Polarization Extinction Ratio	PER	As per Para. 2.3		
	End-face Geometry:				
	Apex Offset	AO	As per Para. 2.3		
	Radius of Curvature	RC	As per Para. 2.3		
	Optical Fibre Protrusion	OFP	As per Para. 2.3		
	Variation of Insertion Loss	$\Delta$ IL	-0.4	+0.4	
	Insertion Loss	IL	As per Para. 2.3		
Return Loss	RL	As per Para. 2.3			
Polarization Extinction Ratio	PER	As per Para. 2.3			
End-face Geometry:					
Apex Offset	AO	As per Para. 2.3			
Radius of Curvature	RC	As per Para. 2.3			
Optical Fibre Protrusion	OFP	As per Para. 2.3			
Random Vibration Initial Measurements  Measurements during testing.  Final Measurements	Insertion Loss	IL	As per Para. 2.3		dB
	Return Loss	RL	As per Para. 2.3		
	Polarization Extinction Ratio	PER	As per Para. 2.3		
	End-face Geometry:				
	Apex Offset	AO	As per Para. 2.3		
	Radius of Curvature	RC	As per Para. 2.3		
	Optical Fibre Protrusion	OFP	As per Para. 2.3		
	Variation of Insertion Loss	$\Delta$ IL	-0.4	+0.4	
	Transient Loss Threshold	TL	As per Para. 2.3		
Insertion Loss	IL	As per Para. 2.3			
Return Loss	RL	As per Para. 2.3			
Polarization Extinction Ratio	PER	As per Para. 2.3			
End-face Geometry:					
Apex Offset	AO	As per Para. 2.3			
Radius of Curvature	RC	As per Para. 2.3			
Optical Fibre Protrusion	OFP	As per Para. 2.3			

Test Reference per ESCC No. 3420	Characteristics	Symbols	Limits		Units	
			Min	Max		
<b>Mechanical Shock</b> Initial Measurements  Measurements during testing.  Final Measurements	Insertion Loss Return Loss Polarization Extinction Ratio End-face Geometry: Apex Offset Radius of Curvature Optical Fibre Protrusion	IL RL PER  AO RC OFP	As per Para. 2.3 As per Para. 2.3 As per Para. 2.3  As per Para. 2.3 As per Para. 2.3 As per Para. 2.3		dB	
	Variation of Insertion Loss Transient Loss Threshold	$\Delta$ IL TL	-0.4   +0.4 As per Para. 2.3			
	Insertion Loss Return Loss Polarization Extinction Ratio End-face Geometry: Apex Offset Radius of Curvature Optical Fibre Protrusion	IL RL PER  AO RC OFP	As per Para. 2.3 As per Para. 2.3 As per Para. 2.3  As per Para. 2.3 As per Para. 2.3 As per Para. 2.3			
	<b>Torsion</b> Initial Measurements  Measurements during testing.  Final Measurements	Insertion Loss Return Loss Polarization Extinction Ratio End-face Geometry: Apex Offset Radius of Curvature Optical Fibre Protrusion	IL RL PER  AO RC OFP	As per Para. 2.3 As per Para. 2.3 As per Para. 2.3  As per Para. 2.3 As per Para. 2.3 As per Para. 2.3		
		Variation of Insertion Loss	$\Delta$ IL	-0.4   +0.4		
		Insertion Loss Return Loss Polarization Extinction Ratio End-face Geometry: Apex Offset Radius of Curvature Optical Fibre Protrusion	IL RL PER  AO RC OFP	As per Para. 2.3 As per Para. 2.3 As per Para. 2.3  As per Para. 2.3 As per Para. 2.3 As per Para. 2.3		

Test Reference per ESCC No. 3420	Characteristics	Symbols	Limits		Units	
			Min	Max		
Static Side Load Initial Measurements  Measurements during testing.  Final Measurements	Insertion Loss Return Loss Polarization Extinction Ratio End-face Geometry: Apex Offset Radius of Curvature Optical Fibre Protrusion	IL RL PER  AO RC OFP	As per Para. 2.3 As per Para. 2.3 As per Para. 2.3  As per Para. 2.3 As per Para. 2.3 As per Para. 2.3		dB	
	Variation of Insertion Loss	$\Delta$ IL	-0.4	+0.4		
	Insertion Loss Return Loss Polarization Extinction Ratio End-face Geometry: Apex Offset Radius of Curvature Optical Fibre Protrusion	IL RL PER  AO RC OFP	As per Para. 2.3 As per Para. 2.3 As per Para. 2.3  As per Para. 2.3 As per Para. 2.3 As per Para. 2.3			
	Optical Fibre/Cable Retention Initial Measurements  Measurements during testing.  Final Measurements	Insertion Loss Return Loss Polarization Extinction Ratio End-face Geometry: Apex Offset Radius of Curvature Optical Fibre Protrusion	IL RL PER  AO RC OFP	As per Para. 2.3 As per Para. 2.3 As per Para. 2.3  As per Para. 2.3 As per Para. 2.3 As per Para. 2.3		
		Variation of Insertion Loss	$\Delta$ IL	-0.4		+0.4
		Insertion Loss Return Loss Polarization Extinction Ratio End-face Geometry: Apex Offset Radius of Curvature Optical Fibre Protrusion	IL RL PER  AO RC OFP	As per Para. 2.3 As per Para. 2.3 As per Para. 2.3  As per Para. 2.3 As per Para. 2.3 As per Para. 2.3		

Test Reference per ESCC No. 3420	Characteristics	Symbols	Limits		Units
			Min	Max	
High Temperature Storage Initial Measurements	Insertion Loss	IL	As per Para. 2.3		
	Return Loss	RL	As per Para. 2.3		
	Polarization Extinction Ratio	PER	As per Para. 2.3		
	End-face Geometry:		As per Para. 2.3		
	Apex Offset	AO	As per Para. 2.3		
	Radius of Curvature	RC	As per Para. 2.3		
	Optical Fibre Protrusion	OFP	As per Para. 2.3		
Final Measurements	Insertion Loss	IL	As per Para. 2.3		
	Return Loss	RL	As per Para. 2.3		
	Polarization Extinction Ratio	PER	As per Para. 2.3		
	End-face Geometry:		As per Para. 2.3		
	Apex Offset	AO	As per Para. 2.3		
	Radius of Curvature	RC	As per Para. 2.3		
	Optical Fibre Protrusion	OFP	As per Para. 2.3		
Mating Durability Initial Measurements	Insertion Loss	IL	As per Para. 2.3		dB
	Return Loss	RL	As per Para. 2.3		
	Polarization Extinction Ratio	PER	As per Para. 2.3		
	End-face Geometry:		As per Para. 2.3		
	Apex Offset	AO	As per Para. 2.3		
	Radius of Curvature	RC	As per Para. 2.3		
	Optical Fibre Protrusion	OFP	As per Para. 2.3		
Measurements during testing.	Variation of Insertion Loss	$\Delta$ IL	-0.4	+0.4	
Final Measurements	Insertion Loss	IL	As per Para. 2.3		
	Return Loss	RL	As per Para. 2.3		
	Polarization Extinction Ratio	PER	As per Para. 2.3		
	End-face Geometry:		As per Para. 2.3		
	Apex Offset	AO	As per Para. 2.3		
	Radius of Curvature	RC	As per Para. 2.3		
	Optical Fibre Protrusion	OFP	As per Para. 2.3		



**APPENDIX A**  
**AGREED DEVIATIONS FOR DIAMOND SA (CH)**

Items Affected	Description of Deviations						
Para. 2.1.1.1, Deviations from the Generic Specification: Deviations from Screening Tests – Chart F3	On completion of Screening Tests and prior to delivery, the components' ferrules including the end-face surface may be subjected to a polishing process in accordance with Diamond SA procedure DF-51 as specified in the PID.						
Para. 2.1.1, Deviations from the Generic Specification: Optical and Geometrical Measurements	Para. 8.6.1.4, Polarization Extinction Ratio: Polarization Extinction Ratio may be measured on the component in accordance with the Diamond SA PER test procedure as specified in the PID.						
Para. 1.4.1.1(d), The ESCC Component Number - Characteristics Codes - Optical Connector B Type	<p>The following code shall be used for optical fibre cable assemblies with commercial optical connectors on Side B, for use in unqualified, non-space applications:</p> <table border="1" data-bbox="593 772 1385 981"> <thead> <tr> <th data-bbox="593 772 778 846">Connector B Type</th> <th data-bbox="778 772 890 846">Code</th> <th data-bbox="890 772 1385 846">Remarks</th> </tr> </thead> <tbody> <tr> <td data-bbox="593 846 778 981">Commercial Connector</td> <td data-bbox="778 846 890 981">C</td> <td data-bbox="890 846 1385 981">Connector type to be used shall be agreed with the Manufacturer and stipulated in the Purchase Order. e.g. E-2000, FC</td> </tr> </tbody> </table>	Connector B Type	Code	Remarks	Commercial Connector	C	Connector type to be used shall be agreed with the Manufacturer and stipulated in the Purchase Order. e.g. E-2000, FC
	Connector B Type	Code	Remarks				
Commercial Connector	C	Connector type to be used shall be agreed with the Manufacturer and stipulated in the Purchase Order. e.g. E-2000, FC					